

(12) **UK Patent Application** (19) **GB** (11) **2 164 569 A**

(43) Application published 26 Mar 1986

(21) Application No **8519075**

(22) Date of filing **29 Jul 1985**

(30) Priority data

(31) **843769** (32) **25 Sep 1984** (33) **FI**

(51) INT CL<sup>4</sup>  
**A61M 11/02**

(52) Domestic classification  
**A5T BC**

(56) Documents cited  
**EP A2 0111163**  
**WO A1 8402656**

(58) Field of search  
**A5T**

(71) Applicant  
**Etela-Hameen Keuhkovammayhdistys R Y (Finland),  
Birger Jaarlinkatu 4 B, 13100 Hameenlinna, Finland**

(72) Inventor  
**Taisto Hakkinen**

(74) Agent and/or address for service  
**R. R. Prentice & Co., 34 Tavistock Street, London,  
WC2E 7PB**

(54) **Inhalation dispenser intended for accurate dispensing of predisposing drugs administered to persons with respiratory disease at the examination phase and/or of drugs to be administered in spray form in the course of therapy**

(57) An inhalation dispenser (10) comprises a mouthpiece, a drug atomizer, a first tubular connector for conducting drive pressure to the drug atomizer, a second tubular connector for conducting respiration air from a spirometer to the drug atomizer, and an atomizing time control (34) for setting the quantity of drugs to be administered. The inhalation dispenser (10) is provided with an atomizing starting time control (35) for selecting the atomizing starting moment to coincide with the beginning of the inspiration phase found by examination to be favourable for the particular patient. The inhalation dispenser (10) is provided with an inspiration flow control for setting the inspiration flow velocity advantageous to the patient to be of desired magnitude, with an inspired air measuring means (37) for measuring the respiratory volume of the patient on each breath, and with a breath counter means (38).

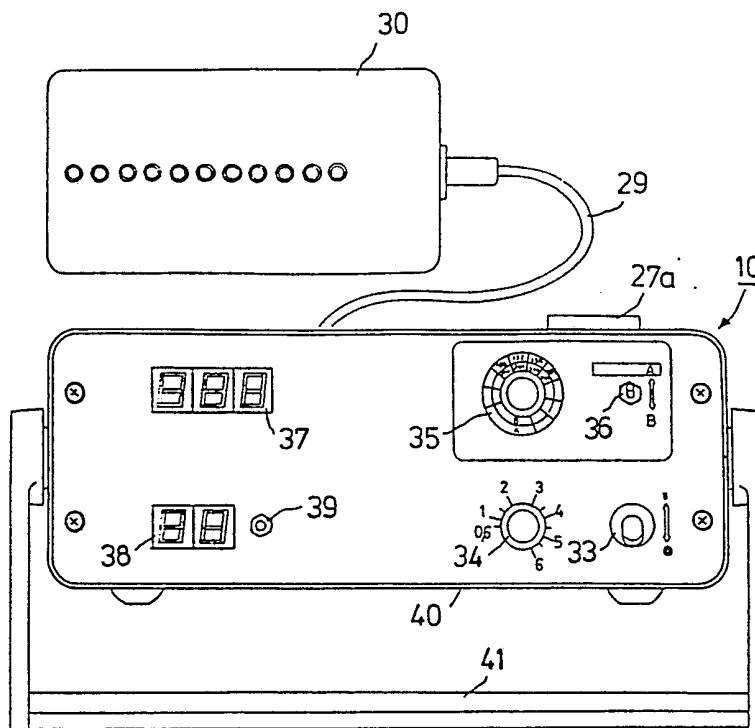

FIG. 1

GB 2 164 569 A

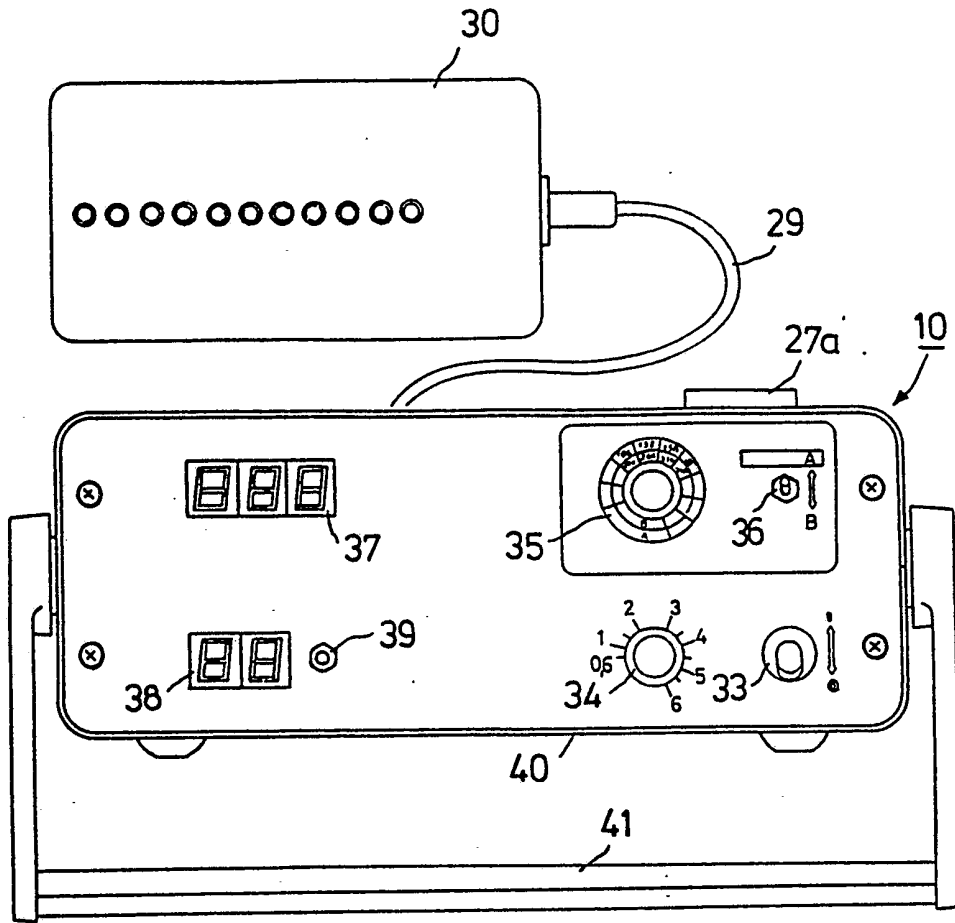

FIG. 1

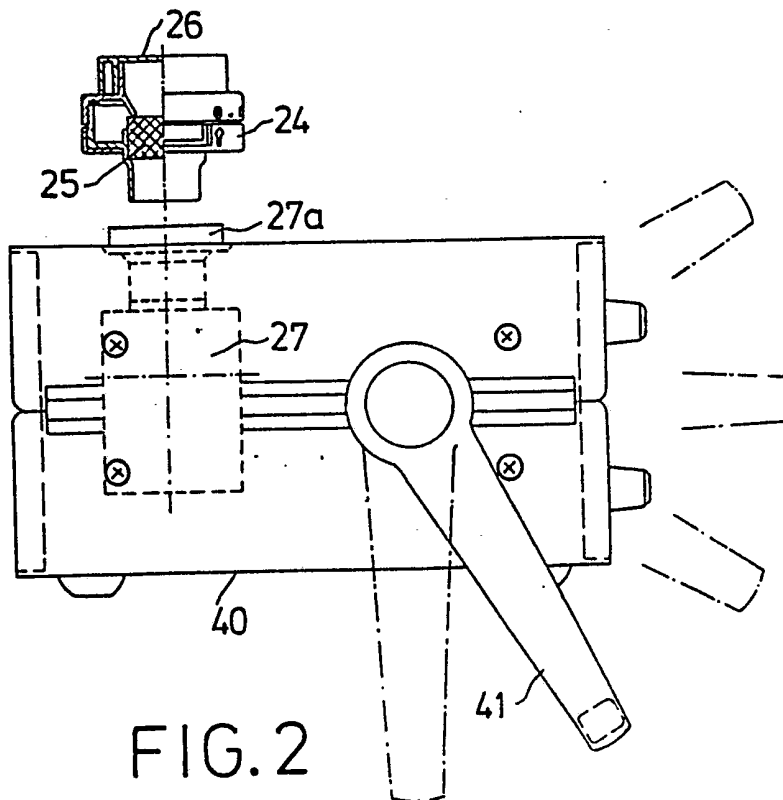

FIG. 2

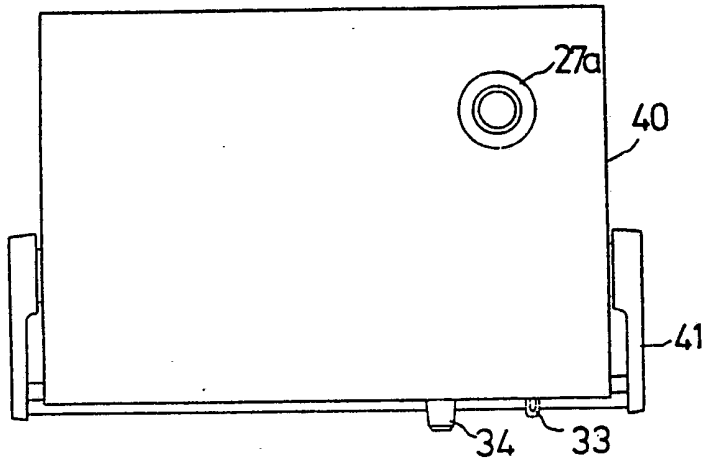

FIG. 3

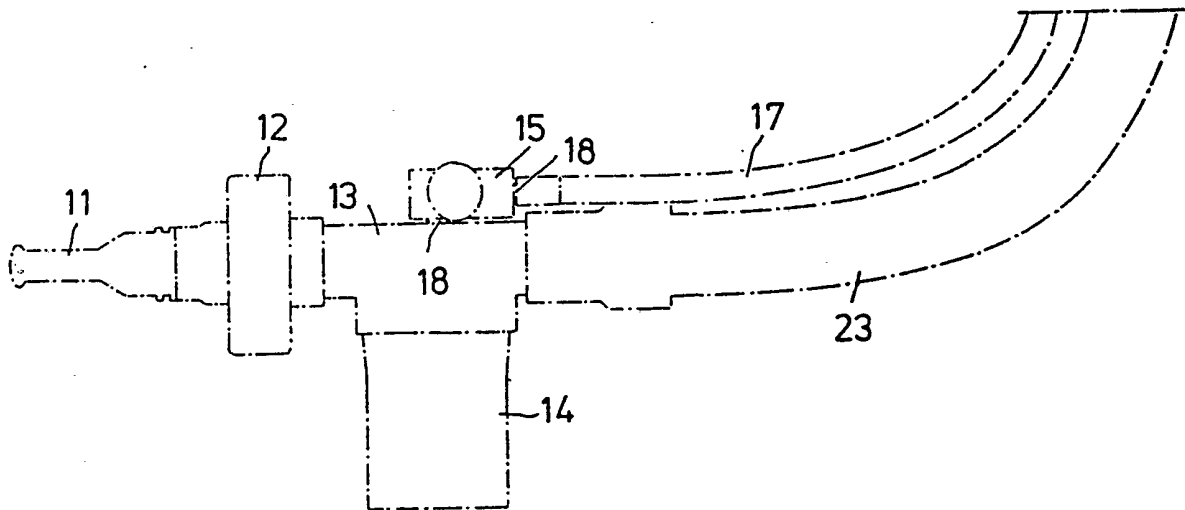

FIG. 5

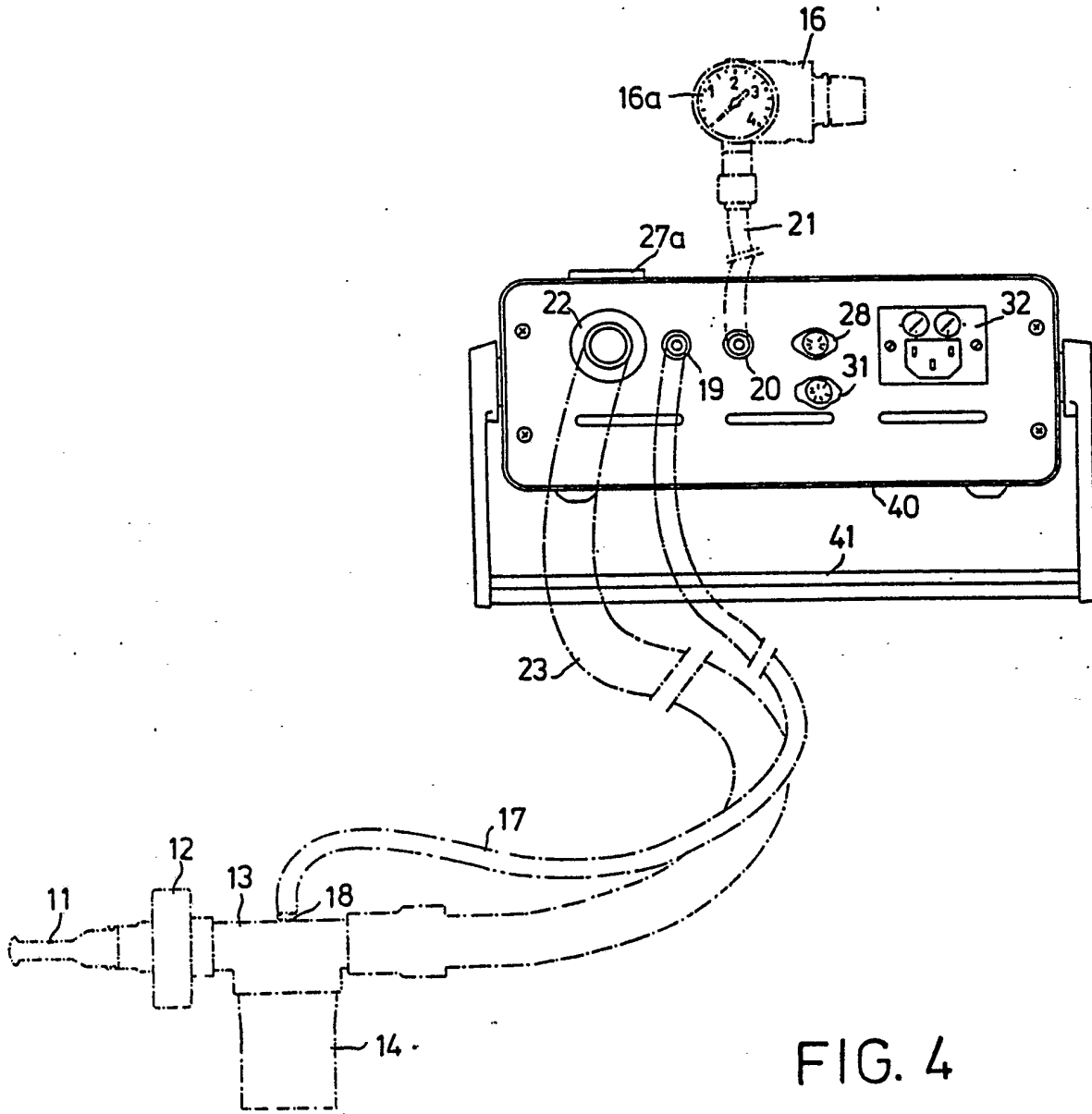

FIG. 4

## SPECIFICATION

**Inhalation dispenser intended for accurate dispensing of predisposing drugs administered to persons with respiratory disease at the examination phase and/or of drugs to be administered in spray form in the course of therapy**

The present invention concerns an inhalation dispenser intended for accurate dispensing of predisposing drugs administered to persons with respiratory disease at the examination phase and/or of drugs to be administered in spray form in the course of therapy, said inhalation dispenser comprising a mouthpiece, a drug atomizer, a first tubular connector for conducting drive pressure into the drug atomizer, a second tubular connector for conducting respiration air from a spirometer to the drug atomizer, and an atomizing time control for setting the quantity of drugs administered.

In the earlier Finnish patent application No. 830359 of the same applicant, a respirator means has been disclosed which is provided with timing devices for adapting the operation period and the rest period of the respirator to conform to a breathing rhythm appropriate for the patient. Said respirator means of prior art is active throughout the respiration period, spraying e.g. drugs into the respiratory passages of the patient. With said respirator means of prior art, the duration of the atomizing period of the drug atomizer cannot be pre-selected to be appropriate for each patient.

Through the state of art, an inhalation dispenser is known which is provided with an atomizing time control, with which the length of the atomizing time can be controlled during which the drug atomizer sprays drugs into the respiratory passages of the patient. This inhalation dispenser of prior art is started with a press button, whereby the drug atomizer atomizes drugs into the respiratory passages of the patient for a pre-selected atomizing time.

The inhalation dispensers present known present numerous drawbacks. With these inhalation dispensers the starting time of atomizing is not arbitrarily selectable to make the start of drug atomizing coincide favourably with a given phase of inspiration, experimentally found for each patient. In presently known inhalation dispensers it is not possible either to influence the patient's inspiration flow velocity nor to measure the inspired air in order to ascertain the patient's respiratory volume on each breath.

The object of the present invention is to achieve an improvement of inhalation dispensers known in the art. A more detailed aim of the invention is to provide an inhalation dispenser which enables extremely accurate dosage of drugs to be administered in spray form in such manner that drug dispensing can be started at commencement of the inspiration phase, found by examination to be favourable for the individual patient. One more aim of the invention is to provide an inhalation dispenser which enables the inspiration flow to be controlled in order to achieve an inspiration flow velocity which is favourable to the patient. Still one

aim of the invention is to provide an inhalation dispenser by which the inspired air quantity can be measured in order to measure the patient's respiratory volume on each breath. Yet one more aim of the invention is to provide an inhalation dispenser in which all controls described in the foregoing can be arbitrarily changed during examination and/or therapy and all the information and settings required in examination and/or therapy can be output with a printer or another equivalent output means, whereby the data of each patient are rapidly retrievable.

The aims of the invention are attained with an inhalation dispenser which is mainly characterized in that the inhalation dispenser is provided with a control for the atomizing starting time for selection of a starting time of atomizing favourable for each patient to coincide with the beginning of the inspiration period as found by examination.

The rest of the characteristic features of the inhalation dispenser of the invention are presented in claims 2—10.

The invention is described in detail, referring to some advantageous embodiments of the invention, presented in the figures of the drawing attached, to which however the invention is not intended to be exclusively restricted.

Fig. 1 presents an advantageous embodiment of the inhalation dispenser of the invention in front view.

Fig. 2 presents the inhalation dispenser of Fig. 1, in elevational view.

Fig. 3 presents the inhalation dispenser of Fig. 1 in top view.

Fig. 4 presents the inhalation dispenser of Fig. 1 in rear view and connected to a drug atomizer having no separate atomizing power control valve.

Fig. 5 presents an alternative to the embodiment of Fig. 4 where the drug atomizer is provided with a separate control valve for atomizing power.

In the embodiment depicted in Figs 1—4, the inhalation dispenser of the invention in general has been indicated by reference numeral 10. In the present embodiment, the inhalation dispenser 10 has been connected, as shown in Fig. 4, to a drug atomizer 13 having no separate atomizing power control valve. As can be seen in Fig. 4, to the drug atomizer 13 has been connected an expiration valve 12, to the end of which has been connected a mouthpiece 11. With the aid of the expiration valve 12, the counter-pressure to the expiration flow can be steplessly controlled. The liquid cup of the drug atomizer 13 carries the reference numeral 14. The drive pressure enters the drug atomizer 13 through a tubular connector 17, and the tubular connector 17 has been attached to the drug atomizer 13 advantageously by means of a cone connection 18. The case 40 of the inhalation dispenser 10 is provided with a connector 19 to which the tubular connector 17 is connected at one end.

In the present embodiment, the drive pressure comes from a compressed air source, not depicted, to a regulator valve 16 provided with pressure gauge 16a. The drive pressure, regulated with the aid of the regulator valve 16, is conducted by a

tubular connector 21 to a connector 20 on the case 40 of the inhalation dispenser 10 and further to the tubular connector 17 through the connector 19. The case 40 of the inhalation dispenser 10 carries a connector 22 to which the respiration air tube 23 has been connected by one end. The respiration air tube 23 has at the other end been connected to the drug atomizer 13. The case 40 of the inhalation dispenser 10 further carries a connector 27a to which the control 24 of the inspiration flow has been connected. The inspiration flow control 24 can be composed of a control means which is, for instance, similar to the expiration valve 12 disclosed in the Finnish Patent No. 56 120, except that the lip membrane provided in said expiration valve 12 is not used. Moreover, to the inspiration flow control 24 has been added a filter 25, and a cover 26. The connector 27a serves at the same time as connector for the flow spirometer 27. The spirometer 27 is depicted in Fig. 2 with interrupted lines.

The case 40 of the inhalation dispenser 10 is furthermore provided with a connector 28 for the inspiration flow velocity meter 30. The meter 30 is connected to the connector 28 by an electric lead 29. The meter 30 is advantageously provided with LED display, as is shown in Fig. 1. Moreover, the case 40 is provided with a connector 31 for a printer or other equivalent output device. By reference numeral 32 is indicated the connector of the mains cord, and by reference numeral 33 the power switch. The case 40 is further provided with an atomizing time control 34 by which the atomizing time can be steplessly controlled.

As taught by the basic idea of the invention, the inhalation dispenser 10 is provided with an atomizing starting time control 35, with the aid of which the starting moment of atomizing can be arbitrarily chosen to coincide with the beginning of the inspiration phase found by examination to be favourable for the particular patient. As shown in Fig. 1, the control 35 is provided with two scales A and B, and by reference numeral 36 is indicated the scale shifter. The control 35 may, naturally, also be of the kind in which no scale shifter 36 is used. Secondly, the inhalation dispenser 10 of the invention is provided with an inspired air measuring means 37, whereby the respiratory volume, in litres, on each breath is known for each patient. The display of the measuring means 37 is preferably digital, as is shown in Fig. 1. Thirdly, the inhalation dispenser 10 is provided with a means 38 counting the number of breaths taken and whereby the number of the inspirations of each patient is known. The breath counter means 38 likewise preferably has a digital display. By the reference numeral 39 is indicated a zero-setting knob, by which the counter 38 may be set to zero after or during the examination or therapy. The reference numeral 4 indicates a handle attached to the case 40 of the inhalation dispenser.

In certain embodiments, the drive pressure from the pressure source is not controlled with the aid of the control valve 16. It is then possible to use the embodiment depicted in Fig. 5, the drive pressure, which enters the connector 20 without preceding regulation and which is conducted by the tube 17 to

the drug atomizer 13, being controlled with the control valve 15 of the drug atomizer 13. This kind of control is in itself known in the art and has been disclosed in the same applicant's earlier Finnish patent No. 830059.

The operation of the inhalation dispenser 10 of the invention in the examination phase and/or in therapy directed on the patient is as follows. Before starting the examination or therapy, the respiratory volume of the patient may be measured with the inhalation dispenser 10 and it is shown in the digital display 37. During examination and/or therapy, the air quantity inspired by the patient with each breath can be continuously followed. The inspiration flow velocity which is favourable to the patient in view of the examination and/or therapy is set with the control 24. The inspiration flow velocity that has been set is constantly indicated by LED display on the meter 30. The commencement of administration of predisposing substances or of a drug, i.e., starting the operation of the drug atomizer 13, is adjusted to coincide with the beginning of the inspiration phase found by examination to be favourable for the particular patient, by means of the control 35. The atomizing time is steplessly adjusted to have the desired length, with the aid of the control 34. It is thus understood that in the inhalation dispenser 10 of the invention the drug atomizer 13 starts when the patient has inspired the air quantity preset with the control 35. The drug atomizer 13 may, of course, be set to start immediately on commencement of inspiration.

Subsequent to the adjustments just described, the operation of the inhalation dispenser 10 of the invention continues in accordance with the settings selected as above, on each breath in similar manner. The number of inspirations can be read from the counter 38. On conclusion of the examination and/or therapy — and/or, naturally, in the course of the examination and/or therapy — the breath counter indication may be set to zero with the zero-setting knob 39. Of course, the settings described above may be arbitrarily changed during the examination and/or therapy.

All information required in the examination and/or therapy, and the settings that have been made, can be output with a printer or other equivalent output device, and the patient information is therefore rapidly retrievable. The inhalation dispenser 10 of the invention renders possible, owing to its properties which have been described, exceedingly accurate dispensing, whereby the patient safety is substantially improved.

In the foregoing, only some advantageous embodiments of the invention have been described, and it is obvious to a person skilled in the art that numerous modifications of them are feasible, within the scope of the inventive idea presented in the claims following below.

## 125 CLAIMS

1. An inhalation dispenser intended for accurate dispensing of predisposing drugs administered to persons with respiratory disease at the examination phase and/or of drugs to be administered in spray

- form in the course of therapy, said inhalation dispenser (10) comprising a mouthpiece (11), a drug atomizer (13), a first tubular connector (17) for conducting a drive pressure to the drug atomizer (13), a second tubular connector (23) for conducting the respiration air from a spirometer (27) to the drug atomizer (13), and an atomizing time control (34) for controlling the quantity of drugs administered, characterized in that the inhalation dispenser (10) is provided with a control (35) of the atomizing starting time for selecting the starting moment of atomizing to coincide with the beginning of the inspiration phase found by examination to be favourable for the particular patient.
- 15 2. Inhalation dispenser according to claim 1, characterized in that the inhalation dispenser (10) is provided with an inspiration flow control (24) for setting the information flow velocity advantageous to the patient to be as desired.
- 20 3. Inhalation dispenser according to claim 1 or 2, characterized in that the inhalation dispenser (10) is provided with an inspired air measuring means (37) for measuring the respiratory volume of the patient on each breath.
- 25 4. Inhalation dispenser according to any one of claims 1—3, characterized in that the inhalation dispenser (10) comprises a breath counter means (38).
- 30 5. Inhalation dispenser according to any one of claims 1—4, characterized in that the atomizing starting time control (35) is provided with two scales (A,B), and that the inhalation dispenser is provided with a scale shifter (36).
- 35 6. Inhalation dispenser according to any one of claims 1—5, characterized in that the inhalation dispenser (10) is provided with an inspiration flow velocity meter (30).
- 40 7. Inhalation dispenser according to any one of claims 1—6, characterized in that the inhalation dispenser (10) is provided with a control valve (16) for controlling the drive pressure of the air flowing into the first tubular connector (17).
- 45 8. Inhalation dispenser according to any one of claims 1—6, characterized in that the drug atomizer (13) is provided with a control valve (15) for controlling the drive pressure of the air flowing in the first tubular connector (17) without being precontrolled, to a desired value before it flows into the drug atomizer (13).
- 50 9. Inhalation dispenser according to any one of claims 1—8, characterized in that between the mouthpiece (11) and the drug atomizer (13) is connected an expiration valve (12) for steplessly controlling the counter-pressure acting against the expiration flow, to a desired value.
- 55 10. Inhalation dispenser according to any one of claims 4—9, characterized in that the inhalation dispenser (10) is provided with a zero-setting knob (39) for setting to zero the digital display of the counter (38).
- 60 11. An inhalation dispenser substantially as described herein with reference to the drawings.