

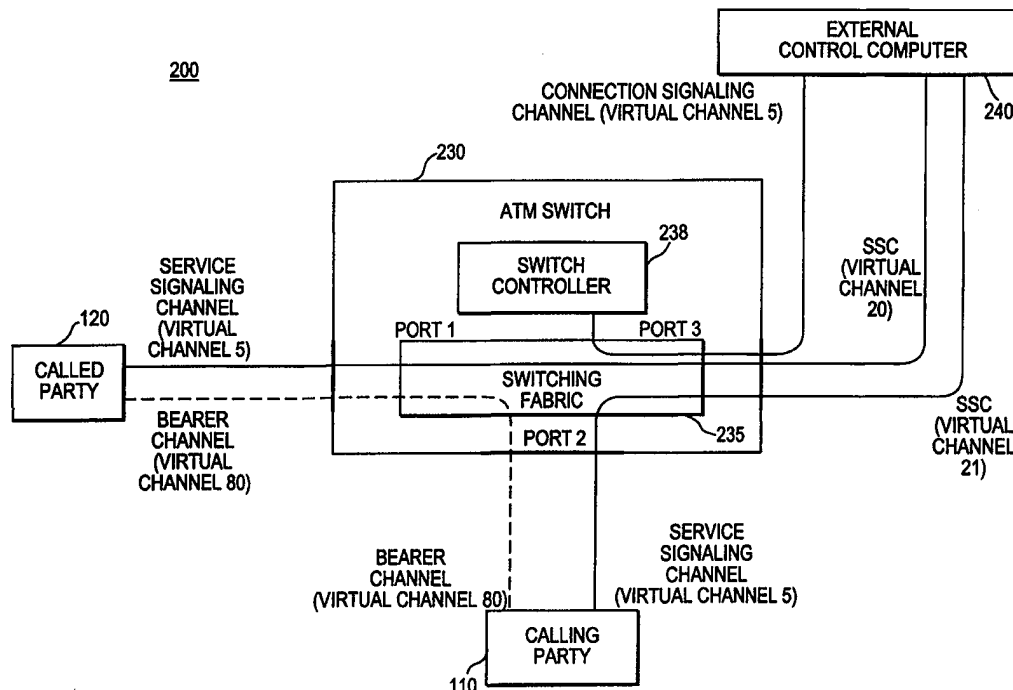

INTERNATIONAL APPLICATION PUBLISHED UNDER THE PATENT COOPERATION TREATY (PCT)

<p>(51) International Patent Classification ⁶ : H04Q 11/04</p>	<p>A1</p>	<p>(11) International Publication Number: WO 98/26627 (43) International Publication Date: 18 June 1998 (18.06.98)</p>
<p>(21) International Application Number: PCT/US97/22773 (22) International Filing Date: 12 December 1997 (12.12.97) (30) Priority Data: 08/766,021 13 December 1996 (13.12.96) US (71) Applicant (for all designated States except US): NORTHERN TELECOM LIMITED [CA/CA]; World Trade Center of Montreal, 38th floor, 380 St. Antoine Street West, Montreal, Quebec H2Y 3Y4 (CA). (72) Inventors; and (75) Inventors/Applicants (for US only): GRAHAM, Gregory [US/US]; 3305 Excalibur Circle, Garland, TX 75044 (US). HOLMES, Kim [CA/US]; 5409 Scenic Drive, Rowlett, TX 75088 (US). STOVALL, Gregory, T. [US/US]; 801 Blossom, Garland, TX 75041 (US). (74) Agents: GARRETT, Arthur, S. et al.; Finnegan, Henderson, Farabow, Garrett & Dunner, L.L.P., 1300 I Street, N.W., Washington, DC 20005-3315 (US).</p>		<p>(81) Designated States: AL, AM, AT, AU, AZ, BA, BB, BG, BR, BY, CA, CH, CN, CU, CZ, DE, DK, EE, ES, FI, GB, GE, GH, GM, GW, HU, ID, IL, IS, JP, KE, KG, KP, KR, KZ, LC, LK, LR, LS, LT, LU, LV, MD, MG, MK, MN, MW, MX, NO, NZ, PL, PT, RO, RU, SD, SE, SG, SI, SK, SL, TJ, TM, TR, TT, UA, UG, US, UZ, VN, YU, ZW, ARIPO patent (GH, GM, KE, LS, MW, SD, SZ, UG, ZW), Eurasian patent (AM, AZ, BY, KG, KZ, MD, RU, TJ, TM), European patent (AT, BE, CH, DE, DK, ES, FI, FR, GB, GR, IE, IT, LU, MC, NL, PT, SE), OAPI patent (BF, BJ, CF, CG, CI, CM, GA, GN, ML, MR, NE, SN, TD, TG).</p> <p>Published <i>With international search report. Before the expiration of the time limit for amending the claims and to be republished in the event of the receipt of amendments.</i></p>

(54) Title: ENHANCED SERVICES FOR ATM SWITCHING USING EXTERNAL CONTROL



(57) Abstract

In a telecommunications network such as an ATM network, a separate processor is provided, outside of the ATM switch, for enhanced services. That processor receives control messages from the calling and called parties and processes the requests enhanced services so the switch need not be reprogrammed.

FOR THE PURPOSES OF INFORMATION ONLY

Codes used to identify States party to the PCT on the front pages of pamphlets publishing international applications under the PCT.

AL	Albania	ES	Spain	LS	Lesotho	SI	Slovenia
AM	Armenia	FI	Finland	LT	Lithuania	SK	Slovakia
AT	Austria	FR	France	LU	Luxembourg	SN	Senegal
AU	Australia	GA	Gabon	LV	Latvia	SZ	Swaziland
AZ	Azerbaijan	GB	United Kingdom	MC	Monaco	TD	Chad
BA	Bosnia and Herzegovina	GE	Georgia	MD	Republic of Moldova	TG	Togo
BB	Barbados	GH	Ghana	MG	Madagascar	TJ	Tajikistan
BE	Belgium	GN	Guinea	MK	The former Yugoslav Republic of Macedonia	TM	Turkmenistan
BF	Burkina Faso	GR	Greece	ML	Mali	TR	Turkey
BG	Bulgaria	HU	Hungary	MN	Mongolia	TT	Trinidad and Tobago
BJ	Benin	IE	Ireland	MR	Mauritania	UA	Ukraine
BR	Brazil	IL	Israel	MW	Malawi	UG	Uganda
BY	Belarus	IS	Iceland	MX	Mexico	US	United States of America
CA	Canada	IT	Italy	NE	Niger	UZ	Uzbekistan
CF	Central African Republic	JP	Japan	NL	Netherlands	VN	Viet Nam
CG	Congo	KE	Kenya	NO	Norway	YU	Yugoslavia
CH	Switzerland	KG	Kyrgyzstan	NZ	New Zealand	ZW	Zimbabwe
CI	Côte d'Ivoire	KP	Democratic People's Republic of Korea	PL	Poland		
CM	Cameroon	KR	Republic of Korea	PT	Portugal		
CN	China	KZ	Kazakstan	RO	Romania		
CU	Cuba	LC	Saint Lucia	RU	Russian Federation		
CZ	Czech Republic	LI	Liechtenstein	SD	Sudan		
DE	Germany	LK	Sri Lanka	SE	Sweden		
DK	Denmark	LR	Liberia	SG	Singapore		
EE	Estonia						

ENHANCED SERVICES FOR ATM SWITCHING
USING EXTERNAL CONTROL

I. BACKGROUND OF THE INVENTION

The present invention relates generally to telecommunication networks and specifically to ATM networks.

Contemporary telecommunications networks provide enhanced services far beyond the traditional basic telephone service. For example, businesses can have 800 numbers that connect to different service centers based on the time of day or the location of the caller. Individuals can have personal numbers that remain the same even after the individual moves to another location. Employees at international companies can call overseas offices using abbreviated phone numbers. And, people can charge calls to a credit card from all over the world.

These enhanced services, however, make switching systems in telephone network central offices increasingly complex. Those systems have grown to incorporate computers with increasingly complex software, and the computers now connect to large databases to hold information such as each customer's features, telephone number translation, and routing information.

Moreover, the information exchanged between switching centers for telephone calls has expanded from simply the dialed phone number to increasingly sophisticated protocols. For example, the protocols now include information about the person or business making the call, the types of services requested, credit card numbers, and database queries and responses.

New services require new protocols and, therefore, new software in the switches. Telephone switches are complex and specialized systems, however, so developing software for them is costly and time consuming. Adding to the expense is the need in many cases to deploy comparable software to support the needed services and protocols at each switching center in the network.

-2-

The problems of adding enhanced services will increase with the growth of Asynchronous Transfer Mode (ATM) switches and networks. ATM is a new telecommunications technology for high speed transfer of data and voice. Current ATM switches provide only basic connection capabilities; no enhanced services have yet been developed for ATM.

If enhanced services are placed in ATM switches using the current ATM network design, providers of such services must rely on the switch vendors to program the switches to support those new services. In addition, if a service provider builds a network using ATM switches from multiple vendors, it must coordinate the implementation of new services with all of its switch vendors, a very formidable task.

One possible solution may come from the ATM Forum, an organization to ensure the interoperability of ATM equipment. The Forum may announce a standard management interface for ATM switches allow an external computer to do more than request connections. Even if this occurs, however, the organizations responsible for the ATM switches may be unwilling to give too much control to the external computer. Therefore this management interface may not provide a complete solution to the problems of enhanced services.

II. SUMMARY OF THE INVENTION

There is, therefore, a need for a system and method to provide enhanced services for ATM and similar networks to make developing and implementing enhanced services easy and inexpensive. Such a system should also ensure that ATM networks can grow and develop with minimal impact to users.

This invention meets these goals by separating the enhanced services from the switching functions and implementing the enhanced services in a centralized computing system. This architecture allows the development, testing, and implementation of the services to take place on a different processor, such as a standard computer with readily available programming

-3-

aids. Providing a separate processor in this manner makes implementing and developing enhanced services easier and less expensive than using conventional techniques.

Additional goals and advantages of the invention appear in the following description, and will be obvious from that description or may be learned by practicing the invention. The goals and advantages of the invention can be realized and attained by the methods and apparatus pointed out in the appended claims.

To achieve the goals and in accordance with the purpose of the invention, as embodied and broadly described herein, the telecommunications network of this invention for routing telephone calls and other communications services from a calling party to a called party, includes an external controller for processing control messages from the calling party requesting connection to the called party, and for generating switch control signals to cause the creation of a bearer channel between the calling party and the called party; and a network switch, coupled to the calling and called parties and separate from but coupled to the external controller, for routing messages from the calling party to the external controller, for receiving the switch control signals from the external controller, and for creating the bearer channel between the calling party and the called party in response to the switch control signals.

A method according to this invention for routing telephone calls in a telecommunications network from a calling party to a called party, includes the steps of processing control messages from the calling party at an external controller requesting connection to the called party; sending switch control signals from the external controller to a network switch, separate from the external controller, to command the switch to create a channel between the calling party and the called party; and establishing in the switch a channel between the called party and the calling party for communication.

Both the foregoing general description and the following detailed description are exemplary and explanatory only and do not restrict the

-4-

invention as claimed. The accompanying drawings, which are incorporated in and constitute a part of this specification, illustrate embodiments of the invention and, together with the description, explain the principles of the invention.

III. BRIEF DESCRIPTION OF THE DRAWINGS

Figure 1 is a block diagram of a conventional ATM network;

Figure 2 is a block diagram of a network constructed consistent with this invention;

Figure 3 is a flow diagram showing the operation of the network in Figure 1 for a conventional telephone call;

Figure 4 is flow diagram showing the operation of the network in Figure 1 for a telephone call with enhanced services; and

Figure 5 is a block diagram of an external control capsule shown in Figure 2.

IV. DESCRIPTION OF THE PREFERRED EMBODIMENTS

Reference will now be made in detail to the preferred embodiments of the invention, examples of which are illustrated in the accompanying drawings. Wherever possible, the same reference numbers will be used throughout the drawings to refer to the same or like parts.

The following discussion focuses on ATM technology, but the invention in its broader aspects can apply to different technologies as well, such as TDM, IP switching, or gigabit Ethernet. The invention is particularly useful for high-speed networks that can rapidly transfer control information.

The invention can be best understood by comparing it with conventional networks, such as in Figure 1. In network 100, when a calling party 110 wants to place a call to a called party 120 through an ATM switch 130, calling party 100's telephone equipment sends signaling messages to switch 130 on virtual channel 5. These signaling messages, which Switching

-5-

Fabric 135 routes to Switch Controller 138, request switch 130 to set up another virtual channel that connects through Switching Fabric 135 to the destination party. Virtual channel 5, called the ' Service Signaling Channel for ease of description, was set up in Switching Fabric 135 as part of the switch provisioning during port initialization.

In response to the signaling messages from Calling Party 110, Switch Controller 138 commands Switching Fabric 135 to create a virtual connection between Calling Party 110 and Called Party 120, and assigns the channel a number, for example 80. Switch Controller 138 chooses an available number from a wide range of channel numbers it supports. Channel 80 is called the Bearer Channel because it bears the actual substance of the call, whether it be voice, video, or data.

Once the virtual connection is created, Switch Controller 138 informs Called Party 120 of an incoming call using a similar Service Signaling Channel on virtual channel 5. Switch Controller 138 also tells Called Party 120 which virtual channel is the Bearer Channel.

Called Party 120 accepts the call by sending an appropriate message to Switch Controller 138 over the Service Signaling Channel, and Switch Controller 138 sends a message over the Service Signaling Channel to Calling Party 110 announcing that the connection has been established over virtual channel 80. The Calling Party and Called Party may now communicate over virtual channel 80.

The protocol for signaling connection requests over virtual channel 5 is defined in the ITU standard Q.2931 for basic connection control. This protocol, however, has no provisions for enhanced services. Enhanced services require software for Switch Controller 138, which normally can only be done by the vendor that builds switch 130.

This invention separates the functions of enhanced services from the function of switching on the ATM network. Doing so uses several aspects of ATM technology. For example, ATM networks make use of high-speed fiber-

-6-

optic transmission facilities. This allows a separate control computer to send control information to the switches to respond quickly enough to create connections properly even when the control computer is located a long distance from the switch.

Another feature of ATM networks is the ability to divide the data on a certain link into an arbitrary number of "virtual channels" that can be routed independently. This feature allows a network to route control protocols to external control computers rather than to a switch controller.

In addition, the external control computer can control the connections in the ATM switch using "proxy signaling" to make any needed ATM connections. Proxy Signaling, which is described in the ATM Forum's standard for the User to Network Interface, version 4.0 allows one user to set up connections on behalf of another.

Figure 2 shows a preferred embodiment of a network 200 consistent with this invention. In network 200, switch 130 has been replaced by Switch 230 and External Control Computer 240. Called Party 120 connects to Port 1 of Switch 230; Calling Party 110 connects to Port 2 of Switch 230; and External Control Computer 240 connects to Port 3 of Switch 230.

Through switch provisioning when Switch 230 is initialized, switching fabric 235 is configured to route the Service Signaling Channel (virtual channel 5) of Calling Party 110 to Service Signaling Channel (virtual channel 21, for example) of External Control Computer 240. Computer 240 has been programmed to understand Q.2931 as well as protocols for enhanced services. Because it is a general purpose computer, such as an IBM RS/6000, Control Computer 240 can be programmed by switch vendors, specialized software companies, or communications service providers.

External Control Computer 240 preferably includes databases to provide enhanced services. The databases can contain switch addresses corresponding to numbers dialed by the calling party, such as an 800 number database and the numbers dialed by the calling party include 800 numbers.

-7-

The databases could also contain abbreviated dial plan databases for virtual private networks, call restriction databases for virtual private networks, or credit card billing databases.

External Control Computer 240 also communicates directly with Called Party 120 via Switching Fabric 235 over its virtual channel 20, and communicates with Switch Controller 238 over its virtual channel 5. Called Party 110 and Called Party 120 communicate over a Bearer Channel (virtual channel 80) through switching fabric 235, as in Figure 1.

Networks operating consistent with this invention should handle standard ATM calls in a way that is indistinguishable from today's switches, at least from the callers' perspective. Operating in accordance with this invention, the network supports the same type of ATM calls as current systems, although networks consistent with this invention use external control instead. For this to work, the ATM switch must be reconfigured in at least three ways.

First, switching fabric 235 must be provisioned to route the calling party 110's Service Signaling Channel (virtual channel 5) to External Control Computer 240, rather than to Switch Controller 238. Second, Switching Fabric 235 must be provisioned to connect virtual channel 5 from Called Party 120 to virtual channel 20 for External Control Computer 240. ATM protocol allows such provisioning, which is necessary because External Control Computer 240 uses its virtual channel 5 for communicating with Switch Controller 238. Because Computer 240's virtual channel 5 allows it to make connections for users, it will be called the Connection Signaling Channel to distinguish it from the Service Signaling Channel. Third, as explained above, virtual channel 5 from Calling Party 110 maps to virtual channel 21 for External Control Computer 240.

Figure 3 shows a flow diagram 300 of the steps that network 200 performs according to this invention for a standard ATM call. First, Calling Party 100 requests from External Control Computer 240 a connection to

-8-

Called Party 120 using virtual channel 5, the Service Signaling Channel (Step 310).

Next, External Control Computer 240 uses proxy signaling on the Connection Signaling Channel to request Switch Controller 238 to establish a connection between Calling Party 110 and Called Party 120 (Step 320). In response, Switch Controller 238 commands Switching Fabric 235 to make a virtual channel between the two parties, and assigns the virtual channel a number, such as 80.

Using proxy signaling, Switch Controller 238 informs External Control Computer 240 via the Connection Signaling Channel that a connection has been set up using channel number 80 (Step 330). External Control Computer 240 in turn uses the Service Signaling Channel on Called Party 120's virtual channel 5 to inform Called Party 120 of an incoming call on virtual channel 80 (Step 340).

Called Party 120 accepts the call by sending an appropriate acceptance message back to External Control Computer 240 over the Service Signaling Channel of virtual channel 5. External Control Computer 240 then sends a message over the Service Signaling Channel on virtual channel 21 to Calling Party 110 indicating that the connection is established over virtual channel 80 (Step 350). The Calling Party and Called Party may now communicate over virtual channel 80.

The preferred embodiment may also be used for enhanced services, such as time-of-day 800 number translation. Figure 4 shows a flow chart 400 containing the preferred steps for such an operation.

First, Calling Party 110 requests a connection to an 800 number using its virtual channel 5 (step 410). Next, External Control Computer 240 consults an 800 number database to find possible translations for the number (step 420). Because there can be multiple entries in the database for an 800 number, based, for example, on time of day, External Control Computer 240 applies the needed criteria, such as time of day, to select the proper entry.

Then, External Control Computer 240 uses proxy signaling to request a connection from Switch Controller 238, and the remainder of the call proceeds as in Figure 3 (Step 430).

Other enhanced services can proceed in a similar manner. Requests are sent over Service Signaling Channels to External Control Computer 240. Computer 240 responds to the requests for enhanced services by performing desired processing, causing Switch Controller 238 to make the needed connections and sending messages to Called Party 120 or Calling Party 110. These enhanced service need not require any hardware changes to ATM Switch 230. They only require software changes in External Control Computer 240.

Figure 5 shows a preferred embodiment of External Control Computer 240 to carry out the functions described above. Computer 240 contains a processing section 510 to perform the necessary data analysis, decision-making, and other processing. Input/Output section 520 couples to switch 230 and other external input and output devices such as modems, keyboards, and monitors, through appropriate drivers. Memory 530 includes databases 540 to provide data to enhanced services, service programs 550 to provide the logic flow for decoding the requests for enhanced services and implementing these services, and programming memory 560 needed for processing.

It will be apparent to those skilled in the art that various modifications and variations can be made in the methods and apparatus of this invention without departing from the scope or spirit of the invention. For example, the invention will work with different switches and different control computers. Also, Switch 230 can actually contain several switches, and External Control Computer 240 can include several computers.

Other embodiments of the invention will be apparent to those skilled in the art from consideration of the specification and practice of the invention. The specification and examples should be considered as exemplary. The true scope and spirit of the invention are determined by the following claims.

-10-

WHAT IS CLAIMED IS:

1. A telecommunications network for routing communications from a calling party to a called party, comprising:
 - external controller means for processing control messages from the calling party requesting connection to the called party, and for generating switch control signals to cause the creation of a bearer channel between the calling party and the called party; and
 - network switch means, coupled to the calling and called parties and separate from but coupled to the external controller means, for routing messages from the calling party to the external controller means, for receiving the switch control signals from the external controller means, and for creating the bearer channel between the calling party and the called party in response to the switch control signals.
2. The telecommunications network of claim 1, wherein the network switch means is a single switch.
3. The telecommunications network of claim 1, wherein the network switch means includes a plurality of switches
4. The telecommunications network of claim 1, wherein the external controller means is a single computer.
5. The telecommunications network of claim 1, wherein the external controller means includes
 - multiple computers.
6. The telecommunications network of claim 1, wherein the network switch means includes

-11-

means for creating a communications channel between the calling party and the external controller means for the control messages.

7. The telecommunications network of claim 1, wherein the external controller means includes

means for sending control messages to and receiving control messages from the called party.

8. The telecommunications network of claim 1, wherein the network switch means includes

means for creating a communications channel between the called party and the external controller means for the control messages.

9. The telecommunications network of claim 1 wherein the external controller means includes

means for receiving requests from the calling party for enhanced services, and

means for providing the enhanced services in response to the requests for the enhanced services.

10. The telecommunications network of claim 9, wherein the external controller means further includes

a database containing data used to provide the enhanced services.

11. The telecommunications network of claim 10, wherein the database includes

switch addresses corresponding to numbers dialed by the calling party.

-12-

12. The telecommunications network of claim 10, wherein the database is an 800 number database and the numbers dialed by the calling party include 800 numbers.

13. The telecommunications network of claim 10, wherein the database is an abbreviated dial plan database for virtual private networks.

14. The telecommunications network of claim 10, wherein the database is a call restriction database for virtual private networks.

15. The telecommunications network of claim 10, wherein the database is a credit card billing database.

16. The telecommunications network of claim 1, wherein the network switch means includes
a switch controller for receiving the switch control signals from the external controller means, and
a switching fabric, coupled to the switch controller, for creating the bearer channel.

17. An ATM network for routing telephone calls from a calling party to a called party, comprising:

external controller means for processing control messages from the calling party requesting connection to the called party, and for generating switch control signals to cause the creation of a bearer channel between the calling party and the called party; and

ATM switch means, coupled to the calling and called parties and separate from but coupled to the external controller means, for routing messages from the calling party to the external controller means, for receiving the switch control signals from the external controller means, and for creating

the bearer channel between the calling party and the called party in response to the switch control signals.

18. The ATM network of claim 17, wherein the ATM switch means is a single switch.

19. The ATM network of claim 17, wherein the ATM switch means includes a plurality of switches

20. The telecommunications network of claim 17, wherein the external controller means is a single computer.

21. The telecommunications network of claim 17, wherein the external controller means includes
multiple computers.

22. The ATM network of claim 17, wherein the ATM switch includes means for creating a communications channel between the calling party and the external controller means for the control messages.

23. The ATM network of claim 17, wherein the external controller means includes
means for sending control messages to and receiving control messages from the called party.

24. The ATM network of claim 17, wherein the ATM switch includes means for creating a communications channel between the called party and the external controller means for the control messages.

-14-

25. The ATM network of claim 17, wherein the external controller means includes

means for receiving requests from the calling party for enhanced services, and

means for providing the enhanced services in response to the requests for the enhanced services.

26. The ATM network of claim 17, wherein the external controller means further includes

a database containing data used to provide the enhanced services.

27. The ATM network of claim 26, wherein the database includes switch addresses corresponding to numbers dialed by the calling party.

28. The ATM network of claim 27, wherein the database is an 800 number database and the numbers dialed by the calling party include 800 numbers.

29. The ATM network of claim 27, wherein the database is an abbreviated dial plan database for virtual private networks.

30. The telecommunications network of claim 27, wherein the database is a call restriction database for virtual private networks.

31. The telecommunications network of claim 27, wherein the database is a credit card billing database.

32. The ATM network of claim 17, wherein the ATM switch includes a switch controller for receiving the switch control signals from the external controller means, and

-15-

a switching fabric, coupled to the switch controller, for creating the bearer channel.

33. The telecommunications network of claim 17, wherein the switch controller includes

means for implementing proxy signaling.

34. The telecommunications network of claim 17, further including an access interface.

35. The telecommunications network of claim 17, wherein the switch controller includes an API for establishing connections.

36. A method for routing telephone calls in a telecommunications network from a calling party to a called party comprising the steps of:

processing control messages from the calling party at an external controller means requesting connection to the called party;

sending switch control signals from the external controller means to a ATM switch, separate from the external controller means, to command the switch to create a channel between the calling party and the called party; and

establishing in the switch a channel between the called party and the calling party for communication.

37. The method of claim 36 further including the steps of

sending control messages from the external controller means to the called party through the network switch;

sending control messages from the called party to the external controller means through the network switch; and

sending control messages from the external controller means to the calling party through the network switch.

-16-

38. The method of claim 36, further comprising the steps of:
- sending control switch control signals from the switch to the external controller means informing the external controller means that the channel between the calling party and the called party has been created;
 - sending control messages from the external controller means to the called party informing the called party of an incoming call from the calling party;
 - sending control messages from the called party to the external controller means informing the external controller means that the called party has accepted the incoming call; and
 - sending control messages from the external controller means to the calling party informing the calling party that the channel between the calling party and the called party has been created and that the called party has accepted the incoming call.

39. The method of claim 38, wherein the step of processing control messages from the calling party includes the step of
- retrieving from a database a switch address corresponding to a number dialed by the calling party.

40. The method of claim 39, wherein the step of retrieving a switch address includes the step of
- retrieving from an 800 database the switch address corresponding to an 800 number dialed by the calling party.

41. The method of claim 39, wherein the step of retrieving a switch address includes the step of
- retrieving from an abbreviated dial plan database for virtual private networks database the switch address corresponding to the telephone number dialed by the calling party.

-17-

42. The method of claim 39, wherein the step of retrieving a switch address includes the step of

retrieving from a call restriction database for virtual private networks database the switch address corresponding to the telephone number dialed by the calling party.

43. The method of claim 39, wherein the step of retrieving a switch address includes the step of

retrieving from a credit card database information corresponding to the telephone number dialed by the calling party.

44. A method for routing telephone calls in an ATM network from a calling party to a called party comprising the steps of:

processing control messages from the calling party at an external controller means requesting connection to the called party;

sending switch control signals from the external controller means to an ATM switch, separate from the external controller means, to command the switch to create a channel between the calling party and the called party; and

establishing in the switch a channel between the called party and the calling party for communication.

45. The method of claim 44 further including the steps of

sending control messages from the external controller means to the called party through the ATM switch;

sending control messages from the called party to the external controller means through the ATM switch; and

sending control messages from the external controller means to the calling party through the ATM switch.

-18-

46. The method of claim 44, further comprising the steps of:
- sending control switch control signals from the ATM switch to the external controller means informing the external controller means that the channel between the calling party and the called party has been created;
 - sending control messages from the external controller means to the called party informing the called party of an incoming call from the calling party;
 - sending control messages from the called party to the external controller means informing the external controller means that the called party has accepted the incoming call; and
 - sending control messages from the external controller means to the calling party informing the calling party that the channel between the calling party and the called party has been created and that the called party has accepted the incoming call.
47. The method of claim 44, wherein the step of processing control messages from the calling party includes the step of
- retrieving from a database a switch address corresponding to a number dialed by the calling party.
48. The method of claim 46, wherein the step of sending switch control signals includes the step of
- using proxy signaling to control the ATM switch.
49. The method of claim 46, wherein the step of retrieving from a switch address includes the step of
- retrieving from an 800 database the ATM switch address corresponding to an 800 number dialed by the calling party.

-19-

50. The method of claim 46, wherein the step of retrieving from a switch address includes the step of

retrieving from an abbreviated dial plan database for virtual private networks database the switch address corresponding to the telephone number dialed by the calling party.

51. The method of claim 46, wherein the step of retrieving from a switch address includes the step of

retrieving from a call restriction database for virtual private networks database the switch address corresponding to the telephone number dialed by the calling part.

52. The method of claim 46, wherein the step of retrieving from a switch address includes the step of

retrieving from a credit card database information corresponding to the telephone number dialed by the calling party.

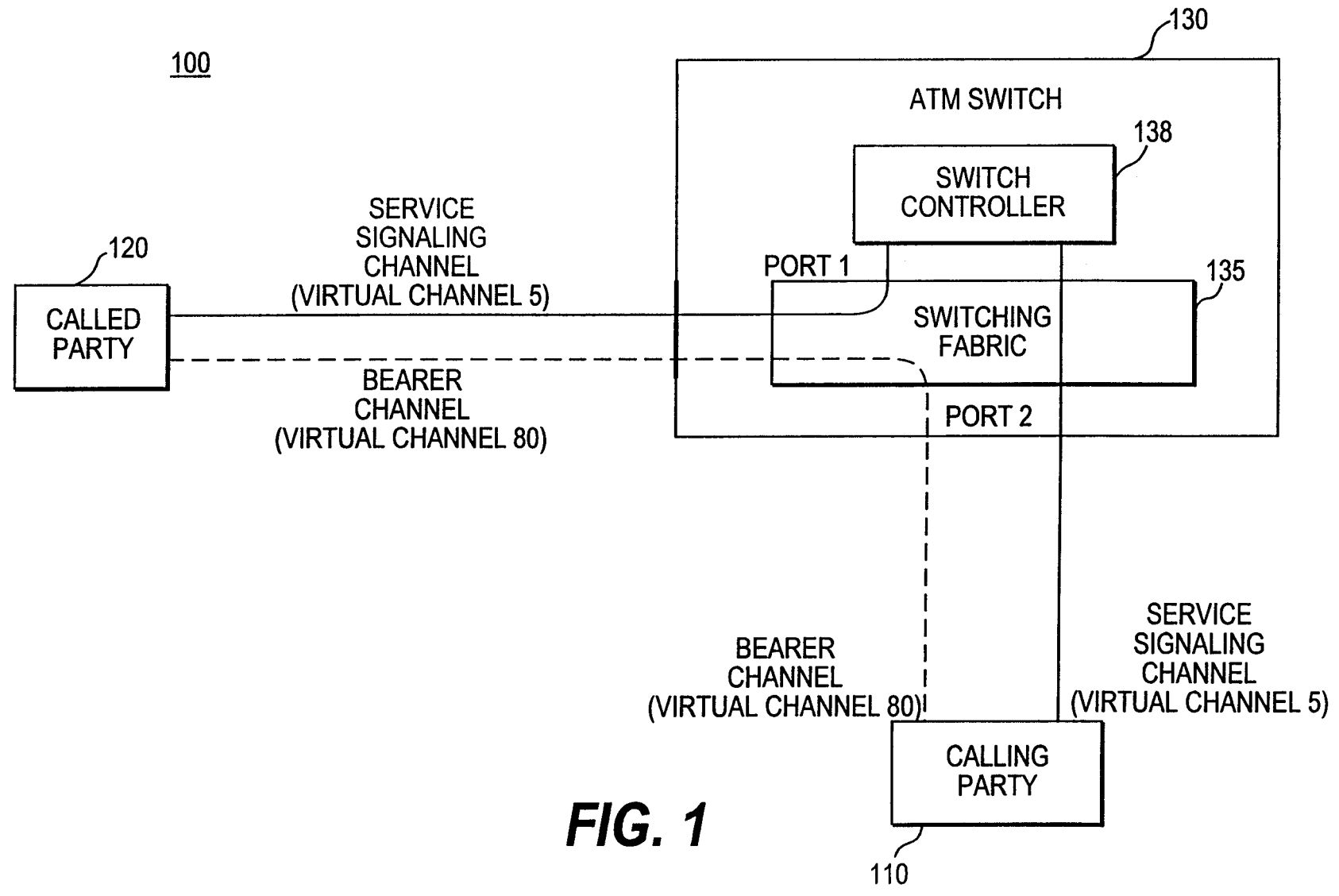

FIG. 1

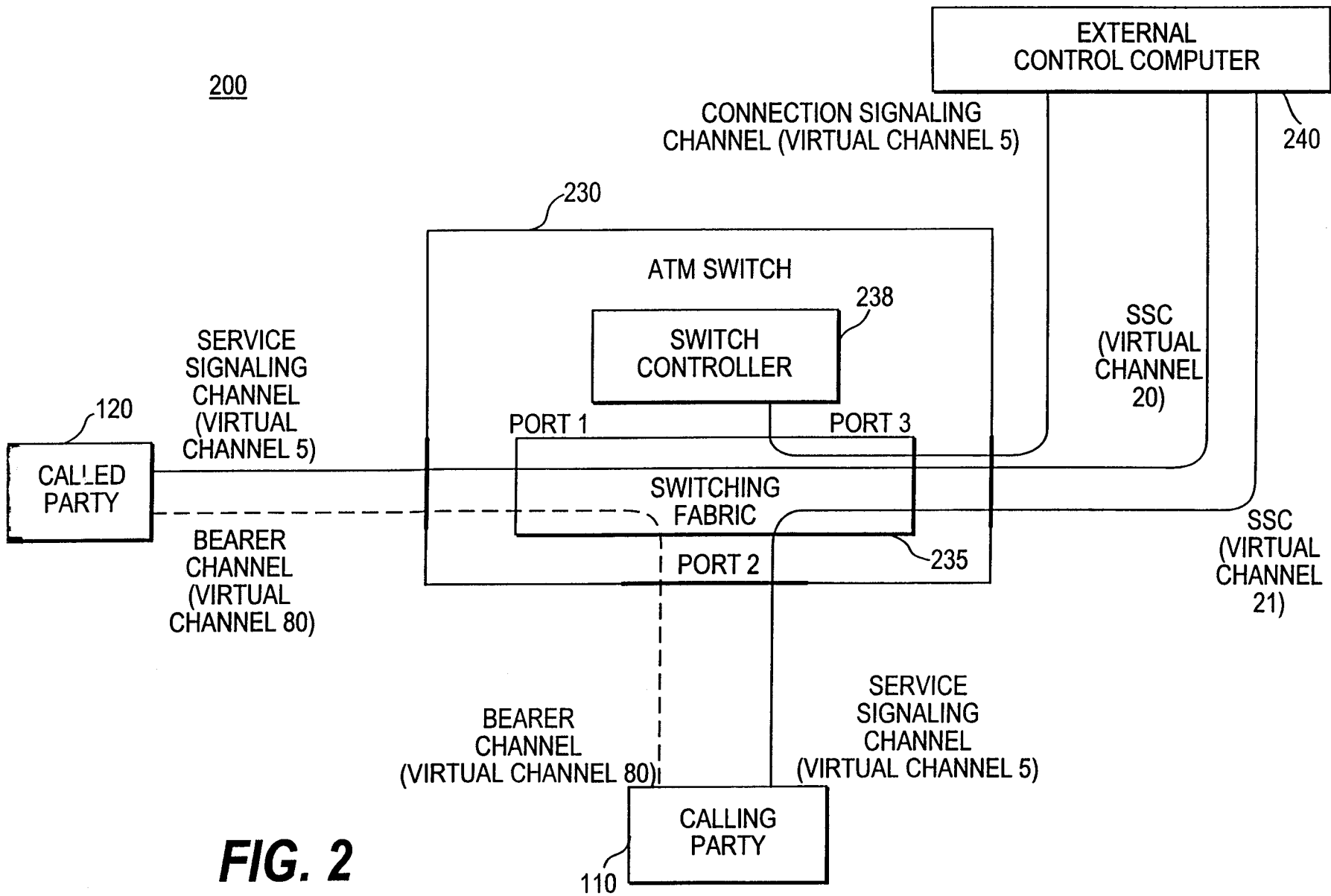

FIG. 2

300

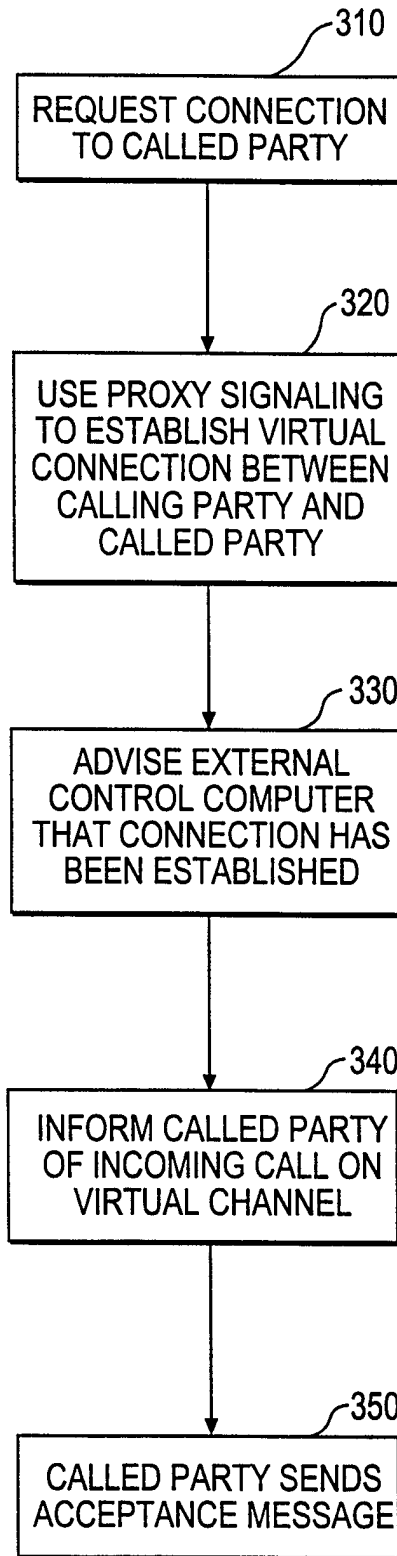

FIG. 3

400

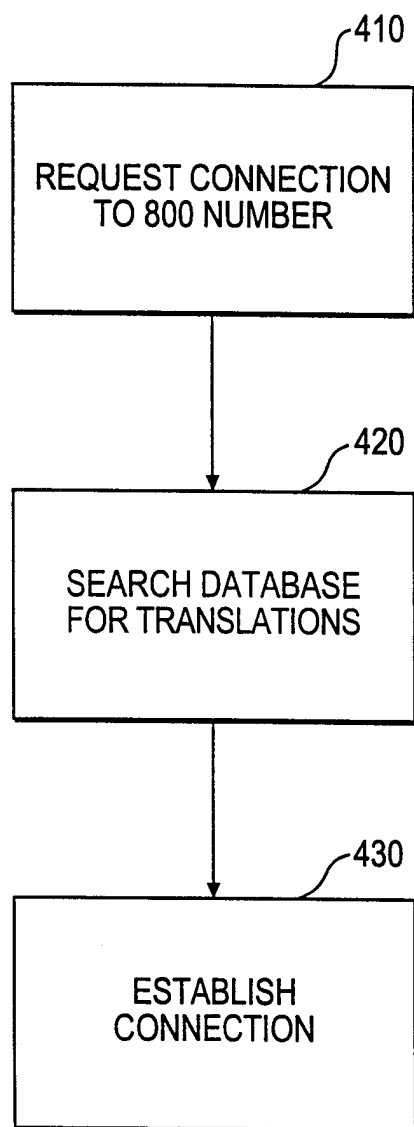

FIG. 4

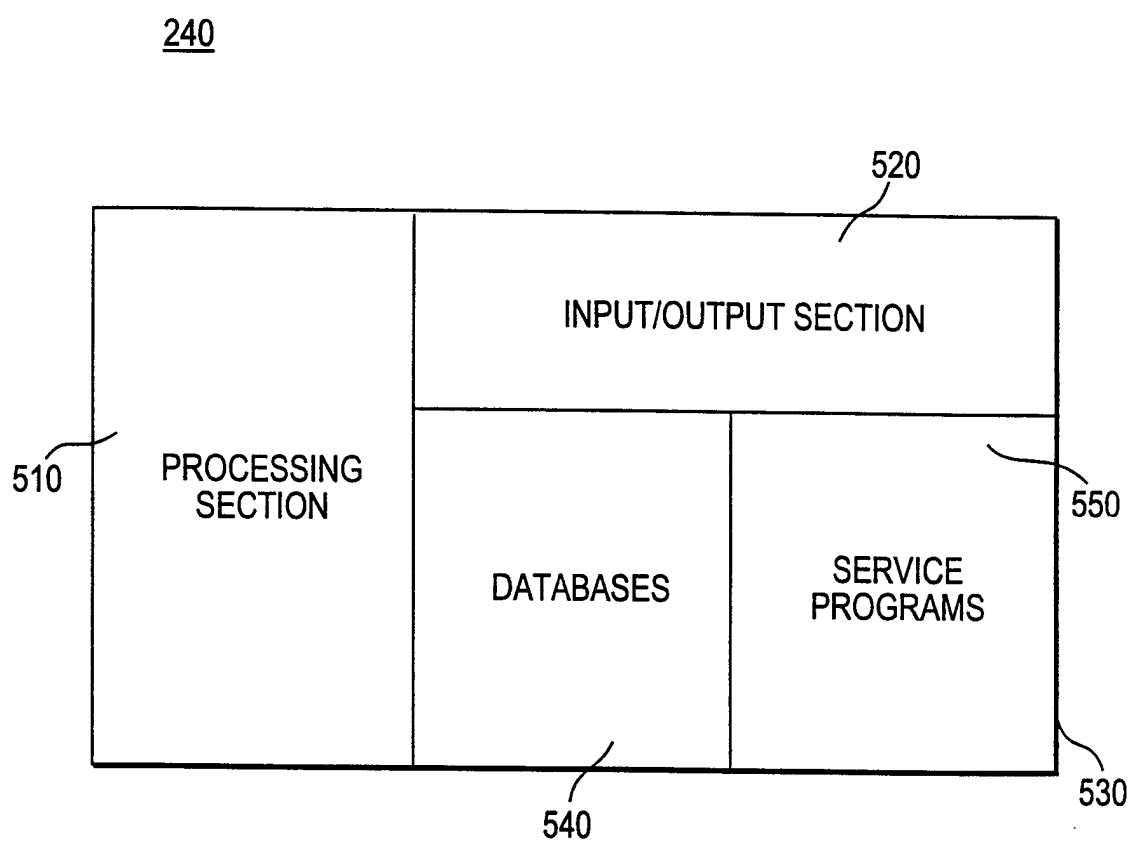

FIG. 5

INTERNATIONAL SEARCH REPORT

International Application No

PCT/US 97/22773

A. CLASSIFICATION OF SUBJECT MATTER

IPC 6 H04Q11/04

According to International Patent Classification (IPC) or to both national classification and IPC

B. FIELDS SEARCHED

Minimum documentation searched (classification system followed by classification symbols)

IPC 6 H04Q

Documentation searched other than minimum documentation to the extent that such documents are included in the fields searched

Electronic data base consulted during the international search (name of data base and, where practical, search terms used)

C. DOCUMENTS CONSIDERED TO BE RELEVANT

Category °	Citation of document, with indication, where appropriate, of the relevant passages	Relevant to claim No.
X	<p>WO 95 08881 A (BELL COMMUNICATIONS RES) 30 March 1995</p> <p style="padding-left: 40px;">see page 3, line 9 - page 4, line 10; claim 1</p>	<p>1, 2, 6-8, 16-18, 22-24, 32, 34, 36, 37, 44, 45</p>
A	<p style="text-align: center;">---</p> <p>EP 0 482 551 A (FUJITSU LTD) 29 April 1992</p> <p style="padding-left: 40px;">see claims 1,2; figures 3A-D</p> <p style="text-align: center;">-----</p>	<p>1, 17, 36, 44</p>

Further documents are listed in the continuation of box C.

Patent family members are listed in annex.

° Special categories of cited documents :

"A" document defining the general state of the art which is not considered to be of particular relevance

"E" earlier document but published on or after the international filing date

"L" document which may throw doubts on priority claim(s) or which is cited to establish the publication date of another citation or other special reason (as specified)

"O" document referring to an oral disclosure, use, exhibition or other means

"P" document published prior to the international filing date but later than the priority date claimed

"T" later document published after the international filing date or priority date and not in conflict with the application but cited to understand the principle or theory underlying the invention

"X" document of particular relevance; the claimed invention cannot be considered novel or cannot be considered to involve an inventive step when the document is taken alone

"Y" document of particular relevance; the claimed invention cannot be considered to involve an inventive step when the document is combined with one or more other such documents, such combination being obvious to a person skilled in the art.

"&" document member of the same patent family

Date of the actual completion of the international search

14 May 1998

Date of mailing of the international search report

22/05/1998

Name and mailing address of the ISA

European Patent Office, P.B. 5818 Patentlaan 2
NL - 2280 HV Rijswijk
Tel. (+31-70) 340-2040, Tx. 31 651 epo nl,
Fax: (+31-70) 340-3016

Authorized officer

Veen, G

INTERNATIONAL SEARCH REPORT

Information on patent family members

International Application No
PCT/US 97/22773

Patent document cited in search report	Publication date	Patent family member(s)	Publication date
WO 950881 A	30-03-95	US 5600643 A	04-02-97
		CA 2169960 A	30-03-95
		EP 0746920 A	11-12-96
		JP 9503108 T	25-03-97

EP 0482551 A	29-04-92	JP 2741798 B	22-04-98
		JP 5136810 A	01-06-93
		JP 4157846 A	29-05-92
		CA 2053821 C	07-02-95
		US 5255266 A	19-10-93
