



Europäisches Patentamt  
European Patent Office  
Office européen des brevets

(19)

(11) Publication number:

**0 101 115**  
**A1**

(12)

**EUROPEAN PATENT APPLICATION**

(21) Application number: 83201073.0

(51) Int. Cl.<sup>3</sup>: G 07 D 7/00

(22) Date of filing: 20.07.83

(30) Priority: 20.07.82 NL 8202920

(43) Date of publication of application:  
22.02.84 Bulletin 84/8

(84) Designated Contracting States:  
AT BE CH DE FR GB IT LI LU NL SE

(71) Applicant: **NEDERLANDSE CENTRALE ORGANISATIE VOOR TOEGEPAST-NATUURWETENSCHAPPELIJK ONDERZOEK**  
Juliana van Stolberglaan 148  
NL-2595 CL The Hague(NL)

(72) Inventor: **Havens, William Howard**  
3012, Rickard Briggs Road  
Skaneateles N.Y. 13152(US)

(72) Inventor: **Klumper, Jan Willem, Jr.**  
Raadhuisstraat 69  
NL-2751 AW Moerkapelle(NL)

(72) Inventor: **Koppenaar, Alexander Leopold Ehrhard, Jr.**  
Vrijburgstraat 23  
NL-2275 BX Voorburg(NL)

(74) Representative: **Mommaerts, Johan Hendrik,**  
Dipl.-Phys.  
Octrooibureau Lux Willem Witsenplein 4  
NL-2596 BK Den Haag(NL)

(54) **A device for recognising and examining bank-notes or the like.**

(57) A device for recognising and examining bank-notes (20) or the like, in which a bank note is transported through a transverse light curtain, and the transmission fluctuations caused by the printed patterns are detected by means of a row of light-sensitive cells, (10) the output signals thereof being stored in a matrix buffer memory (30) as a digital picture of the bank-note, said picture being compared with corresponding data relating to a reference banknote of the same value permanently stored in one of a plurality of partial memories, (36a..d), the comparison results of at least a substantial part of the bank-note being statistically processed, all this irrespective of the orientation of the bank-note. Moreover the dimensions, colour and ultra-violet remission of the bank note are determined, at least one of the first two measurements being suitable for determining the value of the bank-note. Since the picture of the bank-note is temporarily held in the buffer memory (30), a repeated comparison is possible, in particular in respect of different orientations of the bank-note. In particular the partial memories contain only a sample relating to discrete parts arbitrarily distributed over at least a substantial part of the reference bank-note.

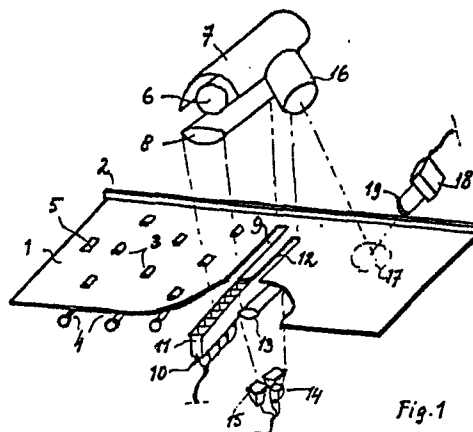

Fig. 1

EP O 101 115 A1

0101115

A device for recognising and examining bank-notes or the like.

There exists a growing need for devices for recognising and examining bank-notes and similar valuable sheet-like objects, in particular for automatic machines such as unmanned petrol-stations, parking houses etc., for money changing machines, money  
5 collectors for banks after office hours, and similar purposes.

From DE-A 2 824 849 a device of this kind is known, comprising guiding means with driving means for transporting a bank-note to be examined, a light source producing a light beam across the transport path of the bank-note, a row of light-sensitive cells  
10 at the other side of said path, the length of said row being at least equal to the largest occurring width of bank-notes, means for processing the output signals of said light-sensitive cells and comparing said signals with reference values stored in a memory, and means for determining at least one dimension of the bank-note and  
15 of its colour.

This known device is provided with means for measuring the length and width of the bank-notes, which measurement can be used to select specific areas to be examined on the presence of deficient spots, e.g. invalidation marks, and these areas are  
20 characterised by co-ordinates in two directions, additional means being provided for suppressing unwanted areas having mirror symmetry in respect of the selected ones.

This known device does not make use of a particular general advantage of the measurement of the transmitted light,  
25 namely that the patterns at both sides of a bank-note which are different and do not register can be examined in one scanning operation, and the specific relationship between both patterns provides a dependable criterion for testing whether a bank-note is genuine or forged. Moreover this known device is not suitable for examining  
30 the validity of soiled and worn as well as brand-new bank-notes, and its operation depends on the existence of specific areas which can be considered as being representative for the validity of the bank-note. The bank-notes are to be introduced in an orientation which corresponds to the co-ordinates of said areas as stored in the device.

From FR-A 2218 579 a device is known which is adapted to examine particular areas of a bank-note provided with a specific print indicating its value, in which one photo-electric sensor is used for scanning the line in question using reflected light.

5 Such a device can only be used for bank-notes of a specific country having printed patterns which are suitable for being analysed in this manner, and, moreover, requires the bank-notes to be introduced in a given orientation.

The invention provides a device of this kind which is  
10 universally applicable, and does not require to insert a bank-note to be examined in a specific orientation. The device provides, furthermore, an extremely dependable examination of bank-notes or the like, and nevertheless allows for the wide variation in quality between new and used bank-notes.

15 The device according to the invention is characterised in that the processing means comprise a matrix buffer memory having as many lines as there are light-sensitive cells, the number of columns corresponding to the number of times that the transverse dimension of said cells is comprised in the length of the largest  
20 area of a bank-note to be examined, each memory cell being adapted to contain a plurality of digital values corresponding to the different light intensities measured by the light-sensitive cells, this in such a manner that this buffer memory will form a digital picture of the transmission pattern of the bank-note, said memory  
25 contents, irrespective of the orientation of the bank-note, then being compared in a comparator with the corresponding contents of partial memories each comprising a standard pattern for a specific bank-note value, said comparator being connected to a circuit adapted to perform a statistical correlation operation, said circuit  
30 being, moreover, connected to comparator circuits for measuring the colour and/or ultraviolet reflection over a larger area, said correlation circuit being adapted to emit an acceptance signal at a sufficient correspondence of both patterns.

By using a matrix buffer memory a digital picture of the  
35 bank-note to be examined is present in the device which can be repeatedly read out, thus allowing a great number of comparisons to be made successively, and, moreover, each memory cell of this buffer memory can contain the digital equivalent of a large number of light intensities, thus providing a fine discrimination for

variations in the printed pattern. Since a complete picture is made, the device is independent of the kind of bank-notes, the variable elements being the reference memories which are to be adapted to the kind of bank-notes to be examined, and the latter 5 can be provided in any number in the device.

Investigating the colour of the bank-notes by spectral analysis provides an additional criterion for genuineness, and can be used, moreover, for determining the kind or value of a bank-note as well as its degree of soiling.

10 In order to simplify the examination of a bank-note irrespective of its orientation, each partial memory will preferably consist of at least four submemories corresponding to different bank-note orientations. If the value of the bank-note can be determined from other characteristics such as dimensions and/or colour, 15 the specific partial memories to be used can be selected on the basis of such characteristics.

The reading sequence control of the buffer memory can be adapted to perform successive reading operations successively shifted by one or more lines and/or columns so as to allow for variations 20 in the position of the pattern on bank-notes and/or in the orientation of the bank-notes in respect of the light-sensitive cells.

The partial memories preferably contain standard information relating to measuring points which are distributed substantially arbitrarily over at least a part of a bank-note, the 25 comparison taking place solely in these points. These points will, in particular, be chosen so that an optimal examination will be obtained with a minimum number of measuring points. Said points can be different for different bank-notes. The arbitrary and variable distribution of these points will prevent that counterfeiters 30 will concentrate on such examined regions as may be the case in the known devices mentioned above.

The correlation operation comprises, in particular, a correlation operation of the ratios of individual measurement values, this in such a manner that a consistent relative deviation 35 over the whole area of measurement can be considered as being acceptable, thus allowing for wear and soiling of old bank-notes.

Comparison operation in the comparator can, in particular, relate to a portion, and in particular one half, of the bank-note, and can be repeated, e.g. with different standards, for another portion

if the first-mentioned operation is not sufficiently decisive, so that partially damaged bank-notes can be nevertheless accepted.

Comparison operation will, in particular, be performed only if the dimensions, the colour, the ultraviolet reflection 5 or the like of a bank-note comply with the standards which will save time in the case of obviously unacceptable bank-notes.

The colour measuring means are in particular adapted to perform an integration over a substantial part of the width of a bank-note to be examined, it being understood that a detailed 10 examination of the colour is not required.

Finally the colour measuring means can be adapted to calibrate the light intensity measurement on the basis of an intensity measurement of the light source before the arrival of the bank-note. In this manner aging phenomena of the light source 15 can be compensated.

The invention will be elucidated below in more detail by reference to a drawing, showing in:

Fig. 1 a simplified diagrammatical representation in perspective with parts broken away of a device according to the 20 invention;

Fig. 2 two diagrammatical views of a bank-note; and

Fig. 3 a highly simplified block diagram of the processing part of such a device.

The device according to the invention diagrammatically 25 shown in Fig. 1 comprises a guiding plate 1 for supporting a bank-note to be examined. At the left-hand side this plate joins an introduction slot, not shown, of an automatic device from which the present device forms a part, and between said slot and the plate 1 mechanical orientation means, not shown, are provided which 30 ensure that an introduced bank-note is supplied straight against a guiding ridge 2 of the plate 1. In the plate 1 driving wheels 3 are included which are connected to shafts 4, the latter being coupled with a motor, not shown, via strings, toothed belts, chains or the like. If necessary one or more driven pressing belts or the like 35 can be provided above the plate, in order to allow to grip a supplied bank-note unambiguously. In the plate 1 a sensor 5, in particular an electronic-optic sensor, is arranged which is adapted to switch on the driving motor and/or to perform other switching operations at the arrival of a bank-note on the plate 1.

- 5 -

At some distance of the sensor 5 a lamp 6 is arranged above the plate 1 which is metallised or is mounted before a mirror 7, and, if necessary, a heat filter can be provided. If required a condensor lens 8 can be mounted below the lamp 6.

5 Below the lamp 6 a slot 9 is provided in the plate 1 passing the light emitted by the lamp 6. Below the slot 9 a series of light-sensitive cells 10, such as photo-diodes, is arranged which are placed as closely to one another as possible, each cell being enclosed in a tubular enclosure 11 operating as a collimator 10 for defining an associated measuring surface.

Beyond the slot 9 and within the light beam from the lamp 6 a second slot 12 is provided which is narrower than the first one in order to exclude marginal areas of the bank-note which may be damaged. Behind this slot 12 an optical system 13, diagrammatically 15 shown, is arranged which directs the passed beam towards three sensitive cells 14, two of which being provided with associated colour filters 15 having mutually different spectral transmission ranges. By means of these cells the colour of the bank-note portions situated above the slot 12 can be determined, and the cell not pro- 20 vided with a filter provides a reference value for determining the intensity in the partial ranges transmitted by the filters 15.

A part of the light emitted by the lamp 6 comprising ultraviolet radiation is directed, by means of an optical system 16, towards an area 17 of the plate 1. The remitted radiation is col- 25 lected by a sensitive cell 18 with an ultraviolet absorbing filter 19.

As soon as the arrival of a bank-note has been established by the sensor 5, the drive of the wheels 3 and possibly associated pressing belts is switched on. If the lamp 6 does not burn, it is 30 switched on or an economising circuit is switched off. Furthermore processing circuits to be described below are activated. The bank-note passes below the lamp 6 so that the emitted light passes through the bank-note, and is, corresponding to the printed pattern, absorbed or transmitted, and, in correspondence with the translation 35 velocity, a slot-wise scanning over the width of the bank-note in transmission takes place. The intensity of the transmitted light influences the output signal of the different cells 10.

The light passing through the second slot 12 arrives at the cells 14, and the cell without a filter 15 can determine the

- 6 -

total transmitted light intensity within a broad spectral range, and the two other cells divide the spectrum in partial ranges.

The lamp 6 is a lamp having a radiation spectrum extending into the near ultraviolet, and is, for instance, a halogen 5 lamp. The optical system 16 directs ultraviolet radiation towards the moving bank-note, which radiation can give rise to fluorescence of components present in the paper. The intensity of the fluorescence radiation is, then, determined by the cell 18. It has appeared that particular high-quality paper species, which are, inter alia, used 10 for bank-notes, do not or only weakly fluoresce, so that in this manner falsifications on other paper can be detected.

The right-hand end of the plate 1 joins auxiliary means, not shown, for directing accepted bank-notes towards a protected collecting vessel, and refused bank-notes are returned, as usual, 15 towards a return slot or the like.

Since a bank-note to be examined is transilluminated, the print at both sides of the bank-note will influence the transmitted light intensity. Since the print, at least in a substantial part, can consist of complex patterns, and the patterns at both 20 sides, will, generally, not register for a substantial part, a useful examination on acceptability can be obtained when using a sufficient large number of cells 10.

Since scanning takes place over a possibly large width of the bank-note, partial areas in which the most characteristic 25 portions of the printing pattern and watermarks are situated will be scanned with certainty. Moreover it can be accomplished then that local damages of the bank-note need not lead to rejection. To that end the measurement signals of the cells should be statistically processed in such a manner that a safe discrimination threshold 30 can be applied, i.e. that from a given number of local correspondences with a standard which has been fixed on the basis of real bank-notes acceptance will follow.

Apart therefrom it should be ensured that an examination can take place irrespective of the orientation in which a bank-note 35 has been introduced. Although, in transillumination, it is irrelevant which side is above, the printing patterns are generally asymmetric to such an extent that the comparison of the measuring signals with the standard values will be influenced by the orientation of the bank-note. Furthermore the value of the bank-note is, generally, to

- 7 -

be ascertained, since the use of different introduction slots for different values or separately to be actuated selection buttons is generally considered as being objectionable, although the invention does not exclude the use of such means which might simplify the structure of the processing circuits.

The manner in which, according to the invention, recognition and examination of a bank-note is performed will now be described in more detail. Thereto reference will be made to a Netherlands bank-note of, say, f 25,-- as diagrammatically shown in Fig. 2 at 20 in two different views. This bank-note has, at both sides, a substantially unprinted wide margin 21, where value indicating prints 22, at one side a tactile mark for blind people, and at the other side a series number are present, and in the paper a watermark 25 is provided. The lateral margins 26 are unprinted, at one side completely, and at the other side for the greater part, and the other terminal margin 27, which is relatively narrow is unprinted too. The intermediate area 28 is provided with a complex line grid pattern which is different at both sides. The colour is characteristic for the value. All Netherlands bank-notes have the same width but their length increases with the value. The paper comprises substantially no components which give rise to a substantial ultraviolet fluorescence.

If such a bank-note is transported under the lamp 6, the cells 10 will produce a more or less strong signal depending on the local transmittivity, and the cells 14 will produce a signal representing the average transmittivity, in particular in the spectral ranges determined by the filters 15, for a part of the width of the bank-note.

As diagrammatically shown in Fig. 3, the signals of the cells 10 are supplied, by means of a discriminator 29 which is adapted to divide the signal intensities in a plurality of groups and to emit digital signals accordingly, to a buffer or intermediary memory 30 having cells 31 which are, for example, divided into rows and columns. Writing the signals into successive columns is done under control of a sensor 32 connected to the driving means of the wheels 4 so that this will take place in correspondence with the transport velocity of the bank-note. After the bank-note has been completely scanned, the contents of the cells 31 form a picture of the bank-note in the form of a grid, the printing patterns at both



surfaces of the bank-note overlapping each other of course. The contents of the memory cells 31 are, then, a measure for the transmittivity determined by the measuring cells 10. The memory cells can, in particular, each have a capacity of  $2^8$  so that a fine 5 division in the measurement values can be obtained.

The distribution of these measurement values over the cells 31 depends on the orientation of the bank-note when inserted, there being several possibilities such as above/below and left/right. From a provisional scan of the memory cells corresponding 10 to the marginal areas 25 and 27 of the bank-note the position of these areas can be determined, and from the position of, for instance, the value print 22 and, for instance, the tactile marks 23 it can be ascertained which side is directed upwards.

The buffer memory 30 can be scanned by means of row and 15 column connections 33 and 34 resp. By making the scanning succession in the rows and columns dependent on the orientation of the bank-note as determined, a specific memory cell will be in its turn always in the same point of the scanning sequence irrespective of the orientation of the bank-note on the plate 1.

20 The reference values used for comparison are stored in digital form in a plurality of memories 36a..d, each corresponding to a given bank-note value, the number thereof depending on the number of values to be recognised, e.g.  $f$  5,--,  $f$  10,--,  $f$  25,-- and  $f$  100,--. The data read in series from the buffer memory 30 are 25 being compared in a comparator 37, e.g. according to a correlation procedure, with the corresponding values which are read out cell-by-cell from the appropriate memory 36.

In order to switch on the correct memory 36 therefore, the value of the bank-note is to be determined first. In the case 30 of Netherlands bank-notes this can, for instance, be done by measuring the length of the bank-note. This can follow from the contents of the columns in the matrix of cells 31. To that end the last column terminals 34' in Fig. 3 are connected to a counter 38 which can send a set signal to the comparator 37 so as to activate 35 the connections with the associated memory 36 accordingly. It is also possible to measure the length of the bank-note by means of the sensor 5 and a time measuring circuit 39, as has been diagrammatically indicated as well, the timing being provided therein by the sensor 32, and also a direct coupling between the cells 10 or the

circuit 29 and the counting circuit 39 can be used.

The value determination can also be done by means of the colour measurement. The cells 14 are coupled with a circuit 40 which is adapted to determine the intensity ratios and to derive there-  
5 from colour information. The latter circuit can be connected to an auxiliary circuit 40 which, if necessary after integration over the whole area, can perform a comparison with standard values stored in a memory 42. The circuit 41 can have the form of a buffer memory  
10 of strips of the bank-note, and to compare this information with corresponding information from the memories 42. The colour measurement or, if desired, only that of the bank-note portions examined first, can be used as a value characteristic which is sent to the circuit 37 via a connection 43 in order to bring about the value  
15 adjustment. It is also possible to use both value characteristics, viz. length and colour, together, and then a choice among the memories 36 will only be made at a sufficient correlation between both.

Calibrating the device can be done, for instance, just  
20 before the bank-note has reached the slot 9, and the light intensity measured (without a bank-note) can be used as a standard value by reference to which the measurement results can be updated, for instance when the light intensity of the lamp 6 decreases. When a buffer memory 42 is used, the suitable value can be derived there-  
25 from at the correct moment.

The circuit 37 sends the comparison results towards a processing and decision circuit 44 in which these results are processed. Also the comparator circuit 41 for the colour measurements is connected to the circuit 44 in order to allow to include also  
30 the results of the colour measurement into the judgement. The measuring cell 18 is connected to a processing circuit, which can, again, be in the form of a buffer memory, the latter circuit also being connected to the circuit 44.

In the circuit 44 a decision is made on the basis of the  
35 information supplied thereto, and at the output 46 a control signal will be produced which can be used to actuate a gating means for directing the bank-note either to a collecting vessel or to a return slot, and in the first case the further operation of the machine, such as dispensing goods, opening a gate, returning change money etc.,

can be initiated.

The memories 36 and 41 (and 45 as the case may be) can be adjusted as follows. Of the various considered bank-notes the different measurement values are determined and transformed into 5 numerical values. Moreover, and in particular in respect of the colour value, the existing deviations between new and still acceptable used bank-notes can be determined. These data are stored in a suitable memory from which the memories of the devices can be filled. Thus adapted memories for different countries can be 10 made which can be inserted as needed into devices to be delivered.

During the statistical processing in the device, the correlation between the values measured in different points and the corresponding stored values is determined over the whole area, and, as required, the width of the allowed variation range can be 15 fixed. This width should be such that local damages, folds, inscriptions, stains etc., if within reasonable limits, will not lead to rejection, but bank-notes missing considerable parts are to be rejected. If desired different weight factors can be used in the processing of different areas so as to give areas with 20 important pattern elements a greater influence on the examination results.

The examination programme can, for instance, be structured as follows. When, after having passed the sensor, the bank-note reaches the light beam within a given time, and, for instance, the 25 fluorescence remains within the accepted limits, a dimension measurement takes place, and subsequently a colour measurement over the whole surface. If these measurements have been successful, the watermark and, subsequently, the pattern can be examined. If one of the preceding criteria should already lead to rejection, the sub- 30 sequent measurements can be omitted, and the bank-note is immediately returned towards the return slot. Of course the order of importance can be changed.

It will be clear that the various circuits of the block diagram of Fig. 3 can be realised in many ways, and, in particular, 35 can be composed of partial circuits with specific tasks and/or operations, and additional cross-links between these circuits can be provided if a mutual dependency or feed-back is desired.

If bank-notes having a different pattern structure are to be examined, corresponding data are to be introduced, but the

structure of the device does not need to be modified. If, for instance, bank-notes of different values have the same dimensions and colour, such as US dollar bills, the value is completely to be derived from the pattern examination. If, however, these bank-  
5 notes are provided with a magnetic marking, an adapted sensor can be added to the device in the usual way. If the bank-notes, as in the case of (German) DM bank-notes of different values, differ not only in length but also in width, a measurement of the length/width ratio can be used if desired.

10 If a detection of the orientation is not possible or not desired, each partial memory 36 can be divided into four submemories each corresponding to a specific orientation of the bank-note, said submemories participating simultaneously in the comparison, and only the comparison values falling inside the preset variation range  
15 will be used. At the beginning of the comparison it will already appear which submemories are not to be used, which can be switched off then. The same can also be done in the case of different value patterns, and then all the partial memories 36 will be activated until the value has been ascertained.

20 If, as stated before, the pattern examination is to be suppressed if one of the colour and ultraviolet tests or both are negative, a suitable connection 47 should connect the circuit 45 with a control input of comparator 37, and the connection 43 can be used for that purpose as far as the colour measurement is concerned.

25 It is, generally, not necessary to compare the complete contents of the buffer memory 30 with corresponding reference values in a memory 36. In practice two groups of 16 comparison points, each at one side of a centre line 48 (Fig. 2) will be used, said points being arbitrarily distributed over the surface portion in  
30 question. The distribution can be different for different bank-note values, or can even be changed at times. This distribution is determined solely by the memory contents, and the structure of the other circuits remains the same.

In practice the comparison will generally be done in only  
35 one half of the bank-note. However, if the results are dubious or negative, the comparison will be repeated in the other half, if desired with a different correlation threshold, and final rejection will follow if the second comparison results are insufficient too. However, if the device is used for checking the quality of used



bank-notes, e.g. by the issuing central bank, it may be desirable to extend the examination over the whole surface, and using a larger number of reference points may be advisable then.

Furthermore it is possible to use a larger number of submemories in the memories 36 comprising the same information but relating to bank-notes shifted in respect of the desired position. This may, for instance, be useful if the location of the pattern can vary, and only the comparison with the best correlation results will be used. Also in the case of used bank-notes which have been stretched, e.g. by folding, a repetition of the comparison in a shifted position can be useful. The control circuit 35 can also be used to that end, in particular for correcting larger deviations or skew angles.

The correlation operation can also be performed on the ratio between the individual measurement and reference values, which is a better criterion in the case of soiled bank-notes. If, as a whole, a consistent ratio correlation is obtained, the bank-note can be safely accepted.

It will be clear that such a device can also be used for recognising sheet material other than bank-notes, e.g. cheques and the like. Moreover, for forming the light curtain and/or for conducting the transmitted light, light guides can be advantageously used, which allow to direct the light accurately towards the desired point, e.g. for avoiding light losses and/or interactions between neighbouring measuring points, or for enabling to arrange the measuring cells in a more favourable point. By adapting the means for scanning the buffer memory 30 and making the latter sufficiently wide an examination can still take place also at a skew introduction of the bank-note, but this will, of course, complicate the structure. Using a guiding ledge 2 is, therefore, to be preferred, the more so as the further transport of a bank-note at a straight introduction is simplified thereby.

Since the specific structure of the various electronic circuits diagrammatically shown as blocks in Fig. 3 does not form a part of the invention, a detailed description thereof is not required, the more so as such circuits are known per se or can be composed from known and commercially available components by a skilled person.

Claims

1. A device for recognising and examining bank-notes or similar objects, comprising guiding means with driving means for transporting a bank-note to be examined, a light source producing a light beam across the transport path of the bank-note, a row of 5 light-sensitive cells at the other side of said path, the length of said row being at least equal to the largest occurring width of bank-notes, means for processing the output signals of said light-sensitive cells and comparing said signals with reference values stored in a memory, means for determining at least one 10 dimension of the bank-note and of its colour, characterised in that the processing means comprises a matrix buffer memory (30) having as many rows as there are light-sensitive cells (10), the number of columns corresponding to the number of times that the transverse dimension of said cells (10) is comprised in the length of the 15 largest area of a bank-note (21) to be examined; each memory cell (31) being adapted to contain a plurality of digital values corresponding to different light intensities measured by the light-sensitive cells (10), this in such a manner that the buffer memory (30) will form a digital picture of the transmission pattern of the 20 bank-note (21), said memory contents, irrespective of the orientation of the bank-note (21), then being compared in a comparator (37) with the corresponding contents of partial memories (36) each comprising a standard pattern for a specific bank-note value, said comparator (37) being connected to a circuit (44) adapted to perform a sta- 25 tistical correlation operation, said circuits being, moreover, connected to comparator circuits (41, 45) for measuring the colour and/or ultraviolet reflection over a larger area, said correlation circuit (44) being adapted to emit an acceptance signal at a sufficient correspondence of both patterns.

30 2. The device of claim 1, characterised in that each partial memory (36) consists of at least four submemories corresponding to different bank-note orientations.

3. The device of claim 1 or 2, characterised in that a control circuit (35) is adapted for controlling the reading operation of the 35 buffer memory (30) in conformity with different orientations.

4. The device of any one of claims 1..3, characterised in that the partial memories (36) each contain standard values relating to

measuring points distributed substantial arbitrarily over at least a part of the bank-note, the comparison taking place solely in these points.

5        5.    The device of any one of claims 1..4, characterised in that the correlation operation comprises a correlation operation on the ratios of individual measurement values.

6.    The device of any one of claims 1..5, characterised in that the comparison operation of the comparator (37) relates to a portion, and in particular one half, of the bank-note, and is re-  
10 peated with a different threshold for another portion if the first-mentioned operation is not sufficiently decisive.

7.    The device of any one of claims 1..6, characterised in that the comparison operation is performed only if the dimensions, colour, ultraviolet reflection or the like of a bank-note comply  
15 with the standards.

8.    The device of any one of claims 1..7, characterised in that the colour measuring means (12..15) are adapted to perform an integration over a substantial part of the width of a bank-note to be examined.

20        9.    The device of any one of claims 1..8, characterised in that the colour measuring (14,15, 40..42) are adapted to calibrate the light intensity measurements on the basis of an intensity measurement of the light source (6) before the arrival of the bank-note (21).

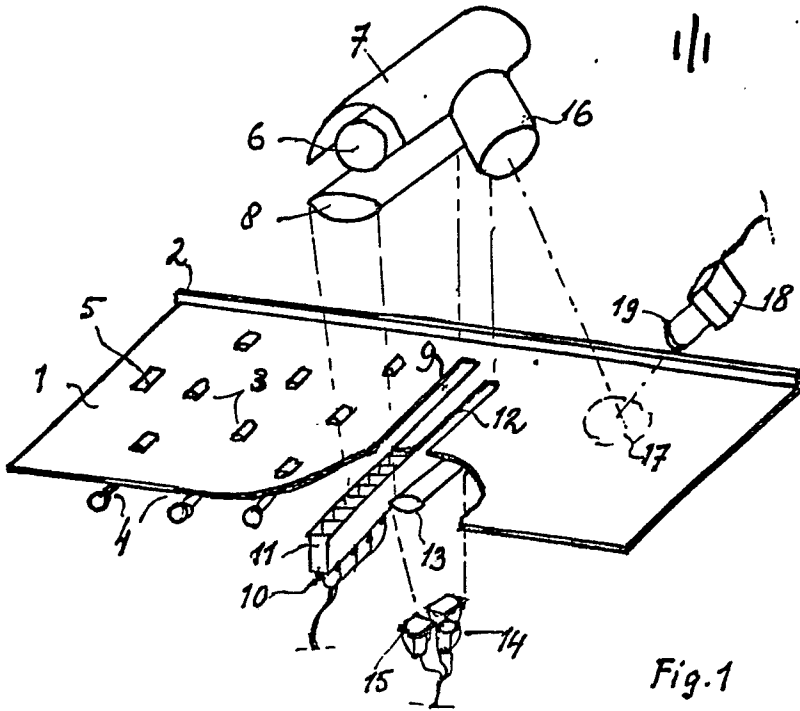

Fig. 1

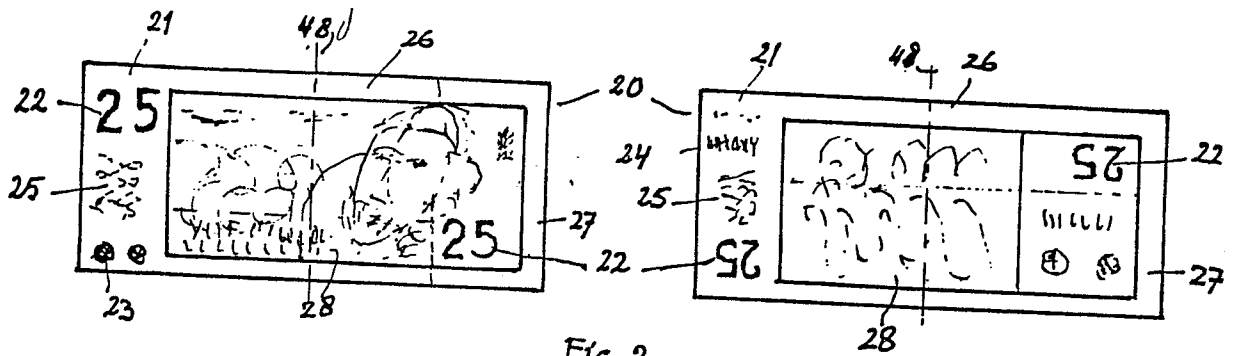

Fig. 2

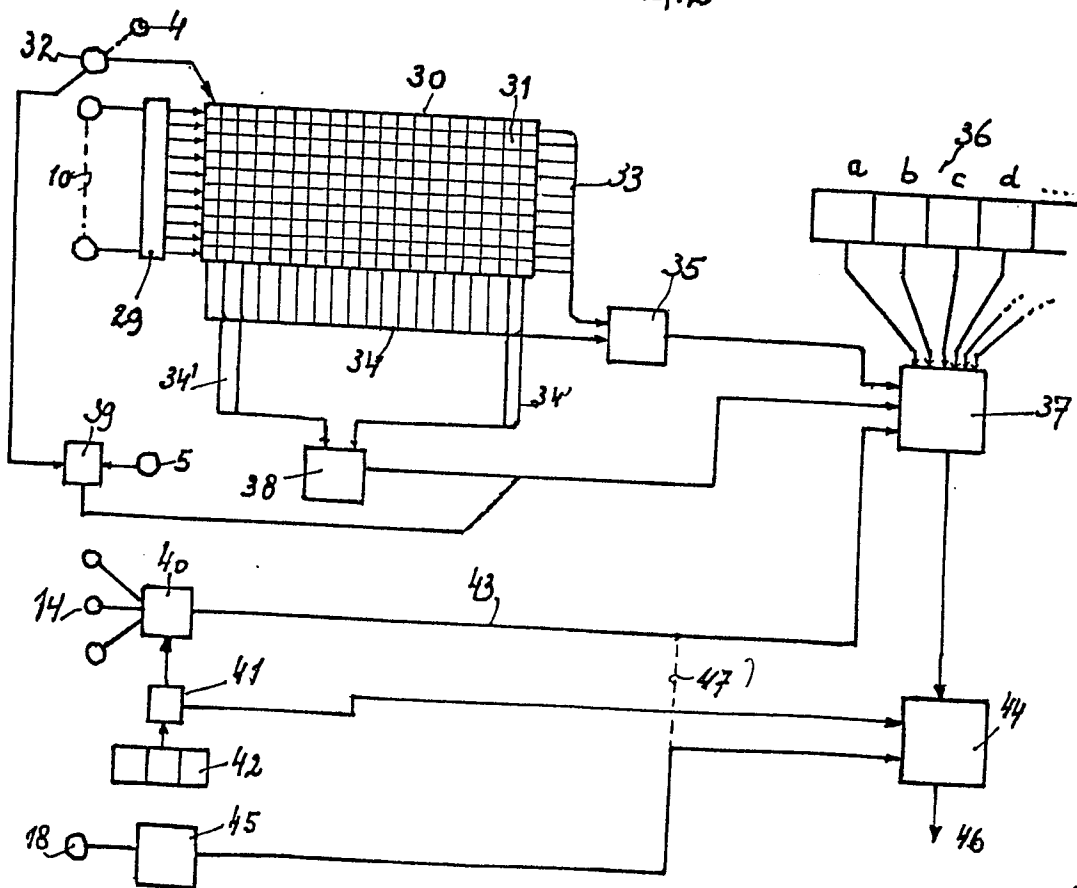

Fig. 3





DOCUMENTS CONSIDERED TO BE RELEVANT			
Category	Citation of document with indication, where appropriate, of relevant passages	Relevant to claim	CLASSIFICATION OF THE APPLICATION (Int. Cl. 3)
P, Y	EP-A-0 078 708 (DE LA RUE SYSTEMS LTD.) * Abstract; page 1, line 10 - page 2, line 17; page 3, line 25 - page 5, line 26; page 6, line 9 - page 7, line 14; page 8, lines 1-6; page 11, lines 25-30; page 12, lines 8-32; figure 1 *	1, 2, 4, 9	G 07 D 7/00
P, Y	EP-A-0 072 237 (DE LA RUE SYSTEMS LTD.) * Abstract; page 12, line 25 - page 13, line 21; page 15, lines 16-25; page 16, lines 1-14; page 17, lines 1-11; page 19, line 14 - page 21, line 15; page 23, lines 17-31; figures 1-4 *	1-4, 7	
A	US-A-3 602 697 (T. TANAKA et al.) * Abstract; column 2, lines 35-45; column 5, lines 7-39; figures 1-3 *	1, 3	TECHNICAL FIELDS SEARCHED (Int. Cl. 3) G 07 D 7/00
D, A	DE-A-2 824 849 (G.A.O.) * Page 12, lines 17-29; page 14, lines 3-9; page 15, line 1 - page 16, line 28; page 19, lines 9-12; page 20, lines 1-27; page 21, lines 8-23; page 24, lines 5-16; page 25, lines 13-21; figures 1-5 *	1, 7	
--- -/-			
The present search report has been drawn up for all claims			
Place of search THE HAGUE		Date of completion of the search 01-11-1983	Examiner RIEB K.D.
<p>CATEGORY OF CITED DOCUMENTS</p> <p>X : particularly relevant if taken alone  Y : particularly relevant if combined with another document of the same category  A : technological background  O : non-written disclosure  P : intermediate document</p> <p>T : theory or principle underlying the invention  E : earlier patent document, but published on, or after the filing date  D : document cited in the application  L : document cited for other reasons</p> <p>&amp; : member of the same patent family, corresponding document</p>			



DOCUMENTS CONSIDERED TO BE RELEVANT			
Category	Citation of document with indication, where appropriate, of relevant passages	Relevant to claim	CLASSIFICATION OF THE APPLICATION (Int. Cl. 3)
A	US-A-4 179 685 (J.B. O'MALEY) * Abstract; column 5, line 6 - column 6, line 18; column 6, line 65 - column 7, line 20; column 7, lines 41-46; column 7, line 66 - column 8, line 2; column 8, lines 34-55; column 9, lines 42-49; figures 1-6b *	1-3,7	
A	EP-A-0 012 723 (GRETAG) * Abstract; page 3, line 14 - page 4, line 21; page 7, lines 8-29; page 8, line 14 - page 9, line 12; page 10, line 15 - page 11, line 8; page 11, lines 27-32; figures *	1,4,7	
A	US-A-4 255 057 (C.J. WILLIAMS) * Abstract; column 1, line 58 - column 3, line 10; figure 1 *	1,9	
D,A	FR-A-2 218 599 (COMPTEURS SCHLUMBERGER) * Page 2, lines 2-10; page 3, lines 10-12; page 4, lines 9-23; page 5, lines 11-14; page 6, line 3 - page 7, line 13; figures 1-4 *	1	
A	FR-A-2 172 074 (LANDIS & GYR A.G.) * Page 2, lines 11-33; page 3, lines 5-32; page 5, lines 1-20; page 6, lines 5-22; figure 1 *	1,5,7	

TECHNICAL FIELDS SEARCHED (Int. Cl. 3)

The present search report has been drawn up for all claims

Place of search THE HAGUE	Date of completion of the search 01-11-1983	Examiner RIEB K.D.
------------------------------	--	-----------------------

**CATEGORY OF CITED DOCUMENTS**

X : particularly relevant if taken alone  
 Y : particularly relevant if combined with another document of the same category  
 A : technological background  
 O : non-written disclosure  
 P : intermediate document

T : theory or principle underlying the invention  
 E : earlier patent document, but published on, or after the filing date  
 D : document cited in the application  
 L : document cited for other reasons  
 & : member of the same patent family, corresponding document

EPO Form 1503 03 82