

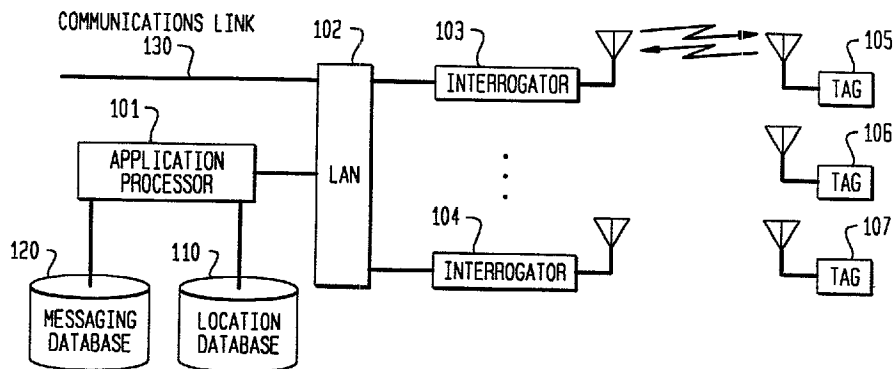

(72) SHOBER, R. Anthony, US
(72) SMITHGALL, David Harry, US
(71) LUCENT TECHNOLOGIES INC., US
(51) Int.Cl.⁶ H04B 7/22, H04Q 7/08
(30) 1996/12/31 (775,738) US
(54) **TELEAVERTISSEUR ET IDENTIFICATEUR INTRAMURAL**
(54) **IN-BUILDING PERSONAL PAGER AND IDENTIFIER**



(57) La présente invention est un dispositif de radiocommunication personnel qui peut recevoir et émettre des signaux radio à modulation de signaux rétrodiffusés. Ce dispositif peut fonctionner dans un mode d'interrogation où il transmet un ensemble de données obligatoires, dans un mode de localisation où son emplacement approximatif peut être déterminé, et dans un mode de messagerie où il peut émettre et recevoir des données. En utilisant la modulation des signaux rétrodiffusés, il peut transmettre des données à plusieurs débits différents. Il comporte un afficheur qui lui permet d'afficher une partie des données qui lui sont transmises, ou toutes ces données. Dans d'autres concrétisations de l'invention, le dispositif peut être utilisé avec des boutons-poussoirs d'introduction de données. Il peut également être utilisé avec plusieurs dispositifs d'alimentation : piles ordinaires, piles rechargeables, cellules solaires, bobines ou autres dispositifs de transfert d'énergie, etc. Un chargeur pour le bloc d'alimentation est également divulgué.

(57) In accordance with the present invention, a radio personal communications device is disclosed, which is capable to receiving modulated radio signals, and capable of transmitting modulated radio signals using modulated backscatter technology. This device can operate in an Interrogation Mode, in which a set of mandatory data is transmitted from the device; in a Location Mode, in which the approximate location of the device can be determined, and in a Messaging Mode, in which data can be transmitted to and received from the device. The device is capable of transmitting information, using modulated backscatter, at more than one data rate. The device contains a display to display some or all of the data transmitted to the device. Alternate embodiments of the invention allow the device to also support pushbuttons to allow data to be input to the device. Alternate embodiments support a variety of powering mechanisms for the device, including batteries, charge storage devices, solar cells, a coil or other energy transfer device, etc. A recharging station is also disclosed in the event the power supply of the device requires recharging.

IN-BUILDING PERSONAL PAGER AND IDENTIFIER**Abstract**

In accordance with the present invention, a radio personal communications device is disclosed, which is capable to receiving modulated radio signals, and capable of transmitting modulated radio signals using modulated backscatter technology. This device can operate in an Interrogation Mode, in which a set of mandatory data is transmitted from the device; in a Location Mode, in which the approximate location of the device can be determined, and in a Messaging Mode, in which data can be transmitted to and received from the device. The device is capable of transmitting information, using modulated backscatter, at more than one data rate. The device contains a display to display some or all of the data transmitted to the device. Alternate embodiments of the invention allow the device to also support pushbuttons to allow data to be input to the device. Alternate embodiments support a variety of powering mechanisms for the device, including batteries, charge storage devices, solar cells, a coil or other energy transfer device, etc. A recharging station is also disclosed in the event the power supply of the device requires recharging.

IN-BUILDING PERSONAL PAGER AND IDENTIFIER

Field of the Invention

This invention relates to wireless communication systems and, more particularly, to an in-building or campus area wireless communication system using modulated backscatter technology.

Related Applications

Related subject matter is disclosed in the following applications filed concurrently herewith and assigned to the same Assignee hereof: U.S. patent applications "Shielding Technology In Modulated Backscatter System," Serial No. _____; "Encryption for Modulated Backscatter Systems," Serial No. _____; "QPSK Modulated Backscatter System," Serial No. _____; "Modulated Backscatter Location System," Serial No. _____; "Antenna Array In An RFID System," Serial No. _____; "Subcarrier Frequency Division Multiplexing Of Modulated Backscatter Signals," Serial No. _____; "IQ Combiner Technology In Modulated Backscatter System," Serial No. _____; "In-Building Modulated Backscatter System," Serial No. _____, referred to below as the "Shober-Protocol" application; "Inexpensive Modulated Backscatter Reflector," Serial No. _____; "Passenger, Baggage, And Cargo Reconciliation System," Serial No. _____. Related subject matter is also disclosed in the following applications assigned to the same assignee hereof: U.S. patent application 08/504188, entitled "Modulated Backscatter Communications System Having An Extended Range"; U.S. Patent Application Serial No 08/492,173, entitled "Dual Mode Modulated Backscatter System,"; U.S. Patent Application Serial No. 08/492,174, entitled "Full Duplex Modulated Backscatter System,"; and U.S. Patent Application Serial No. 08/571,004, entitled "Enhanced Uplink Modulated Backscatter System."

Background of the Invention

Security access systems have been developed to support the automatic identification of personnel, for example to authorize the entrance of an employee into a building. (In this application, we use the term "employee" to mean the person to whom we wish to provide service. Other applications of the invention disclosed here exist in which the receiver of the service is not an "employee", but that term is convenient and we will use it.) Examples of such systems include the provision of a distinctive employee identification badge, perhaps with the employee's picture printed on the badge, which is examined by a guard to determine if access to the

building is authorized. A next logical step is for the employee to carry an identification card which electronically authorizes entrance to the building. For example, "magnetic" key cards exist which are keyed with a particular magnetic signature; and which, when held in close proximity to a magnetic reader, can
5 authorize building entrance. Another example is a card with a magnetic stripe on the back (such as a magnetic stripe used on the back of a credit card); the employee then "swipes" the card through a card reader to authorize building entrance. Still another example of the same concept is a "Smart Card" in which the card is placed either into or on top of an electronic reader which can access data stored on the Smart Card, and
10 this data is the means to authorize building entrance. Recent trends are emphasizing the use of magnetic key cards, magnetic stripe cards, or Smart Cards in order to allow building entrances to be unstaffed, and therefore to reduce costs.

Radio Frequency Identification (RFID) systems represent the next logical evolution in the technologies discussed above. RFID is used for identification
15 and/or tracking of equipment, inventory, or living things. RFID systems are radio communication systems that communicate between a radio transceiver, called an Interrogator, and a number of inexpensive devices called Tags. In RFID systems, the Interrogator communicates to the Tags using modulated radio signals, and the Tags respond with modulated radio signals. In one RFID technique, the Interrogator first
20 transmits a message to the Tag (called the Downlink); then the Interrogator transmits a Continuous-Wave (CW) radio signal to the Tag. The Tag modulates the CW signal using modulated backscattering where the antenna is electrically switched, by the modulating signal, from being an absorber of RF radiation to being a reflector of RF radiation. This Modulated BackScatter, or MBS, allows communications from
25 the Tag back to the Interrogator (called the Uplink). RFID is used today in the security industry to facilitate building access; for example, the use of an RFID Tag to automatically authorize entrance to a building, and/or to record that an individual passed by a particular location. This operation is called the Interrogation Mode; it is a mode of operation in which the Interrogator transmits a signal to all Tags in the
30 reading field, requesting those Tags to respond with data which identifies this Tag. The Tag then transmits this information back to the Interrogator using MBS.

RFID technology represents a considerable improvement over the other building access technologies discussed above. The other technologies have limited range (typically a few inches or less) between the reading device and the card or
35 badge. This limited range requires the employee to place the card or badge in close proximity to the reading device. RFID technology allows this range limitation to be relaxed, at least to some degree, and in some cases relaxed altogether. Some RFID

- 3 -

technologies are inherently short range (i.e., effective range of a foot or two), while other RFID technologies support an Interrogation Mode range exceeding ten feet. This latter range is capable of providing a truly "hands free" operation where the RFID Tag does not have to be removed and held close to the reading device in order
5 to be read.

Beyond the security applications discussed above, employees within a building or campus environment have other needs as well. (For the remainder of this disclosure, we use the term "building" or "in-building" to mean either within a building or within a campus environment which could include a building.) For
10 example, "Location" applications also exist. It is beneficial to know the location of a specific Tag within the building, especially in high-security buildings. Prototype systems, using infrared transmitters, have been developed to allow the location of a "Tag" to be tracked; however there are no commercial products, and infrared technology suffers from lack of range and no ability to pass through objects. For
15 example, if the infrared transmitter is placed inside a person's shirt pocket, the communications path is blocked. For large, expensive items, such as a tractor used in long-distance trucking, it may be cost-effective to place a Global Positioning System (GPS) receiver in the tractor; thus, the position of the tractor can be
20 determined. However, GPS receivers are expensive, not suitable for use by individuals, and not designed for in-building applications. Therefore, there are today no cost-effective solutions to the location problem for individuals within a building or campus environment.

In addition, low speed data "Communications" applications are also present. Let us assume that an employee receives a very important phone call, but
25 the employee is not in his/her office at the time the call is received. About the only reasonable option today is for a secretary to take the call and attempt to find the employee. Let us further assume that an employee receives a very important electronic mail message. Systems are in existence today that allow the electronic mail system to interconnect with a "Paging" system, so that all or part of the
30 electronic mail message appears on the display of the pager. Today, Paging is the most commonly used mechanism to support low speed wireless data communications. However, there are drawbacks to the use of Paging systems. Some Paging systems suffer from poor in-building wireless coverage. Also, some Paging services involve paying usage charges to a service provider on a per-
35 transaction basis. Within a building or campus environment, it is possible to deploy a wireless data LAN; however these products are still relatively expensive. Therefore, low-cost solutions do not exist today for low speed wireless data communications

within a building or campus environment.

Therefore, we have seen that RFID technology, which is inherently a low-cost technology, is making inroads into security applications for the purpose of identifying Tags as they pass a specific reading device. However, there are no low-cost techniques to provide location information within a building or campus environment, and there are no low-cost techniques to provide low speed wireless data communications information within a building or campus environment. There are also no systems that integrate the above capabilities -- Interrogation, Location, and Low Speed Wireless Data Communications (or Messaging) -- in one system. In this invention, we disclose the design of a low cost personal communications device, utilizing modulated backscatter. This device can be used to integrate the functions of Security, Location, and Messaging in a single system with a single infrastructure. This device thus can provide improved security as well as cost-effective in-building or campus-area location and communications services.

15 **Summary of the Invention**

In accordance with the present invention, a radio personal communications device is disclosed, which is capable of receiving modulated radio signals, and capable of transmitting modulated radio signals using modulated backscatter technology. This device can operate in an Interrogation Mode, in which a set of mandatory data is transmitted from the device; in a Location Mode, in which the approximate location of the device can be determined, and in a Messaging Mode, in which data can be transmitted to and received from the device. The device is capable of transmitting information, using modulated backscatter, at more than one data rate. The device contains a display to display some or all of the data transmitted to the device. Alternate embodiments of the invention allow the device to also support pushbuttons to allow data to be input to the device. Alternate embodiments support a variety of powering mechanisms for the device, including batteries, charge storage devices, solar cells, a coil or other energy transfer device, etc. A recharging station is also disclosed in the event the power supply of the device requires recharging.

Brief Description of the Drawing

In the drawing,

FIG. 1 shows a block diagram of an illustrative Radio Frequency Identification (RFID) system;

- 5 -

FIG. 2 shows a block diagram of an illustrative Interrogator Unit used in the RFID system of FIG. 1;

FIG. 3 shows a block diagram of a Tag Unit used in the RFID system of FIG. 1;

5 FIG. 4 shows a block diagram of a Personal Pager and Identifier (PPID);

FIG. 5 shows one embodiment of the physical layout of a PPID;

FIG. 6 shows an alternate embodiment of the physical layout of a PPID;

FIG. 7 shows an RF Detector incorporated in a PPID;

10 FIG. 8 shows a Docking Station and how the PPID could be oriented with respect to the Docking Station.

Detailed Description

MBS Operation

We now describe how a typical RFID system, utilizing MBS, operates.

15 With reference to FIG. 1, there is shown an overall block diagram of a traditional RFID system. An Applications Processor 101 communicates over a Local Area Network (LAN, 102), which could be wired or wireless, to a plurality of Interrogators (103, 104). The Interrogators may then each communicate with one or more of the Tags (105, 107). For example, the Interrogator 103 receives an
 20 information signal, typically from an Applications Processor 101. The Interrogator 103 takes this information signal and Processor 200 properly formats a Downlink message (Information Signal 200a) to be sent to the Tag. With joint reference to FIGS. 1 and 2, Radio Signal Source 201 synthesizes a radio signal, the Modulator 202 modulates this Information Signal 200a onto the radio signal, and the
 25 Transmitter 203 sends this modulated signal via Antenna 204, illustratively using amplitude modulation, to a Tag. The reason amplitude modulation is a common choice is that the Tag can demodulate such a signal with a single, inexpensive nonlinear device (such as a diode).

In the Tag 105 (see FIG. 3), the Antenna 301 (frequently a loop or patch
 30 antenna) receives the modulated signal. This signal is demodulated, directly to baseband, using the Detector/Modulator 302, which, illustratively, could be a single Schottky diode. The result of the diode detector is essentially a demodulation of the incoming signal directly to baseband. The Information Signal 200a is then amplified, by Amplifier 303, and synchronization recovered in Clock Recovery
 35 Circuit 304. The Clock Recovery Circuit 304 can be enhanced by having the

Interrogator send the amplitude modulated signal using Manchester encoding. The resulting information is sent to a Processor 305. The Processor 305 is typically an inexpensive 4 or 8 bit microprocessor; the Clock Recovery Circuits 304 can be implemented in an ASIC (Application Specific Integrated Circuit) which works
5 together with or is incorporated within the integrated circuit containing Processor 305. This Processor 305 can also serve as the driver for an optional Display Unit 309 should this Tag require a display. The Processor 305 generates an Information Signal 306 to be sent from the Tag 105 back to the Interrogator (e.g., 103). This Information Signal 306 is sent to a Modulator Control Circuit 307, which uses the
10 Information Signal 306 to modulate a subcarrier frequency generated by the Frequency Source 308. The Frequency Source 308 could be a crystal oscillator separate from the Processor 305, or a signal derived from the output of a crystal oscillator, or it could be a frequency source derived from signals present inside the Processor 305 -- such as a multiple of the fundamental clock frequency of the
15 Processor. The Modulated Subcarrier Signal 311 is used by Detector/Modulator 302 to modulate the modulated signal received from Tag 105 to produce a modulated backscatter (i.e., reflected signal). This is accomplished by switching on and off the Schottky diode using the Modulated Subcarrier Signal 311, thereby changing the reflectance of Antenna 301. A Battery 310 or other power supply provides power to
20 the circuitry of Tag 105.

There are a variety of techniques for using Modulated Backscatter (MBS) to send information from the Tag to the Interrogator. In some MBS technologies, the Modulator Circuit 307 of the Tag generates a modulated signal, which is amplitude modulated by an Information Signal 306 at frequency f_2 . If the
25 Radio Signal Source 201 generates an unmodulated frequency f_1 , then the Interrogator receives signals inside of the range $(f_1 - f_2)$ to $(f_1 + f_2)$, and generally filters out signals outside of that range. This could be termed the "MBS at baseband" approach. Another approach would be for the Tag to generate two different subcarrier frequencies. The information could be conveyed in a frequency-shift
30 keyed (FSK) fashion with the subcarrier frequency transitioning between these two frequencies. Other modulation schemes are possible as well, such as Phase Shift Keying (PSK) of a single subcarrier frequency (e.g., BPSK, QPSK) or other complex modulation schemes (e.g., MFSK, MASK, etc.).

Returning to FIG. 2, the Interrogator 103 receives the reflected and
35 modulated signal with the Receive Antenna 206, amplifies the signal with a Low Noise Amplifier 207, and demodulates the signal using homodyne detection in a Quadrature Mixer 208. (In some Interrogator designs, a single Transmit (204) and

- 7 -

Receive (206) Antenna is used. In this event, an electronic method of canceling the transmitted signal from that received by the receiver chain is needed; this could be accomplished by a device such as a Circulator.) Using the same Radio Signal Source 201 as used in the transmit chain means the demodulation to baseband is
5 done using Homodyne detection; this has advantages in that it greatly reduces phase noise in the receiver circuits. The Mixer 208 then sends the Demodulated Signal 209 (if a Quadrature Mixer, it would send both I (in phase) and Q (quadrature) signals) to the Filter/Amplifier 210. The resulting filtered signal -- which in this invention is an Information Signal 211 carried on a subcarrier -- is then demodulated from the
10 subcarrier in the Subcarrier Demodulator 212, which then sends the Information Signal 213 to a Processor 200 to determine the content of the message. The I and Q channels of Signal 209 can be combined in the Filter/Amplifier 210, or in the Subcarrier Demodulator 212, or they could be combined in the Processor 200.

Using, e.g., the above techniques, a short-range, bi-directional digital
15 radio communications channel is implemented. A relatively inexpensive implementation is achieved using, as exemplary components, a Schottky diode, an amplifier to boost the signal strength, bit and frame synchronization circuits, an inexpensive 4 or 8 bit microprocessor, subcarrier generation circuits, and a battery. Most of these items are already manufactured in quantities of millions for other
20 applications, and thus are not overly expensive. The circuits mentioned above for bit and frame synchronization and for subcarrier generation can be implemented in custom logic surrounding the microprocessor core; thus, except for a relatively small amount of chip real estate, these functions come almost "for free."

Narrowband Operation

25 Using the above procedures, a two-way digital radio communications channel can be constructed. We desire to extend the range of this two-way digital radio communications channel as much as possible. This involves both extending the range of the Downlink and also extending the range of the Uplink.

Extending the range of the Downlink involves several factors. The
30 Downlink is generally an amplitude modulated signal, which is easily and inexpensively detected by a single nonlinear device, such as a microwave diode. It is important to match the impedances between the antenna and the diode to avoid gratuitous signal attenuation. The data rate of the Downlink must be limited in order to reduce the noise bandwidth of the Downlink signal. We now discuss how the Tag
35 can filter out unwanted signals without increased cost. The Antenna (301) not only performs the tasks of receiving the RF signal, but it also filters RF signals outside of

the antenna bandwidth. For example, at 2.45 GHz, allowable RF carrier frequencies are from 2.400 - 2.485 GHz. The design of the antenna, frequently a patch antenna, covers this frequency band but filters out frequencies beyond this range. An ideal frequency response would be for the antenna sensitivity to be within 3 dB across the allowable frequency range, but to fall off rapidly beyond this range. In addition, the Amplifier (303) also acts as a filter in the sense that the Amplifier is designed to only pass Amplitude Modulated (AM) signals that are within a certain passband around the expected Downlink data rate, which is typically a few kilobits per second. Therefore, although the Tag is relatively simple, it has filtering capability to filter out both RF signals whose frequency is outside the Antenna bandwidth, and also to filter out AM signals whose frequency is outside of the Amplifier passband. This Tag design is also not greatly sensitive to RF transmissions, inside the band of the antenna, whose modulation scheme is primarily constant envelope. Thus, this design allows a robust Tag which is resistant to many potential interfering signals.

Extending the range of the Uplink also involves several factors. First, the noise bandwidth of the Uplink signal must be reduced as much as possible. A number of useful applications can be implemented even if the data rate of the Uplink signal is limited to a few bits per second. Indeed, this limitation of the data rate can be taken to the extreme in which there is no data modulated onto the single subcarrier frequency; in this case, the mere presence or absence of a signal received at this subcarrier frequency indicates an "acknowledgment" or "no acknowledgment" to a previously received message. We further note that the subcarrier frequency can be relatively accurately determined. For example, commercially available crystals exist with a frequency of 32kHz, and an accuracy of ± 100 ppm. Thus, the frequency of this crystal is known to ± 3.2 Hz. The Tag thus generates a subcarrier frequency, f_s , of great accuracy. The Interrogator receives the reflected signal, and demodulates it as discussed above using Homodyne detection. The Filter Amplifier (210) and Subcarrier Demodulator (213) function could then be implemented, together, inside a processor such as a DSP. Narrowband filtering algorithms exist in the literature which can perform digital filtering of the signal with a bandwidth of less than 10 Hz, and where the first sidelobes are depressed 60 dB. Then, the signal strength of the signal received through this digital filter is measured, and that strength is compared to a reference signal strength which is sufficiently above the average noise in that channel when no signal is present such that spurious noise spikes are not misinterpreted as actual signals. In this manner, very weak Uplink signals can be reliably detected. It has been found that, using these techniques, roughly equivalent range in the Downlink and the Uplink can be achieved.

We now discuss the location of the subcarrier frequency f_s . MBS systems exhibit noise in the Uplink signals due to reflections of the RF source from any number of reflectors. Walls and metal objects reflect RF radiation; these reflected signals are received by the Interrogator 103 at the same carrier frequency as they were transmitted. The Quadrature Mixer 208 is operated as a Homodyne Detector and thus is used to cancel these reflections. However, other reflectors generate reflected noise at frequencies away from the main carrier frequency - either from Doppler shifts or, more likely, from reflections off of electronic equipment operating at frequencies near the Subcarrier Frequency. One particularly difficult source of noise is fluorescent lights, which have been shown to produce noise not only at their fundamental 60 Hz (in the United States) frequency, but also at overtone frequencies well up into the tens of thousands of Hertz. It has been found especially helpful to locate the subcarrier frequency f_s such that it falls between multiples of the fundamental 60 Hz frequency. From the 32 kHz crystal, simple circuits can generate the appropriate subcarrier frequency.

Multiple Mode Operation

The basic features of multiple mode operation are that a) the Tag must be capable of receiving a Downlink message; b) the Tag must be told what type of Uplink message it is to transmit, whether it be an actual data message (higher bit rate mode) or a simple acknowledgment message (long range mode), based upon information received in the Downlink message; c) the Tag transmits the requested type of Uplink message; and d) the Interrogator interprets the Uplink message received in a proper manner. Several different types of acknowledgment messages in the long range mode can exist. Generally, an acknowledgment message has a data rate which is much less than the data rate of an actual data message (the higher bit rate mode), thus allowing filtering over a much smaller frequency band, and thus allowing greater range than the higher bit rate mode since the noise bandwidth of the received signal is lessened due to the narrowband filtering. Thus, an acknowledgment message could consist of a low bit rate data message, or it could consist of a single bit of information. As discussed above, to send a single bit of information, the Tag could generate an unmodulated subcarrier frequency which could be modulated onto the incident signal, using modulated backscatter. The Interrogator would then receive a reflected signal with a single frequency tone. Narrowband filtering techniques could then be used to reduce the noise bandwidth and determine the presence or absence of this signal.

- 10 -

The Tag 105 detects and assembles the bits of information sent from the Interrogator 103 into a complete Downlink message. Typically, a pattern of synchronization bits is transmitted at the beginning of the Downlink message; these bits allow the Tag to acquire bit and message synchronization; enabling the Tag to
5 determine the beginning and the end of the Downlink message. The Downlink message contents would include an Address, a Command, optionally include Data, and also include Error Detect. The Command or Data portion of the Downlink message could indicate that the Tag 105 should return a Message to the Interrogator; for example, the Tag could return stored data, such as the Tag ID, or other
10 application-specific data. Another type of Downlink message could indicate that the Tag should send back only a single-bit acknowledgment message.

Thus, the Processor 305 of the Tag 105 determines, in response to information in the Downlink message, what type of Uplink signal to transmit: a data message or a simple acknowledgment message. There are several ways that the Tag
15 105 may transmit either a data message or a simple acknowledgment message so that the Interrogator 103 can, relatively easily, receive and distinguish between these two different types of messages. Referring to FIG. 3, in the event that the Tag 105 is to send a multi-bit information signal, Processor 305 sends the Information signal to the Modulator Control 307, which modulates the signal from Subcarrier Frequency
20 Source 308.

In Tag 105, Processor 305 sends the Information Signal over the Information Signal Lead 306 shown in FIG. 3. In the event that Processor 305 of Tag 105 is to send a "single tone" message consisting of a single information bit, the Information Signal Lead 306 is maintained at a first logic state to indicate that no
25 information message is to be sent. Thus, an unmodulated subcarrier frequency signal is outputted by Modulator Control 307. In the event that Processor 305 determines that a multi-bit message is to be sent, the Information Signal Lead 306 conveys the multi-bit message to Modulator Control 307. This multi-bit message (information signal) is then used to modulate the subcarrier frequency using one of
30 several possible modulation techniques, such as amplitude, phase, frequency, or code modulation.

The Interrogator 103 (FIG. 2) demodulates the subcarrier signal from the received RF signal, and then applies filtering. Given the specifics of the subcarrier frequency, a suitable filtering amplifier is utilized. Subcarrier
35 Demodulator 212 then demodulates the subcarrier signal. The Processor 200 then performs the digital signal processing necessary to decode the information. In some implementations of this invention, the Processor may be a Digital Signal Processor

- 11 -

(DSP); in others, a conventional Microprocessor could be used. To recover a "single tone" acknowledge signal from Tag 105, consisting of a single subcarrier tone, the filtering amplifier would be a narrowband filter. While conventional filtering technologies could be used, it may be most effective to utilize the DSP mentioned
5 above as a narrowband filter. The subcarrier frequency of this single tone is well known; as the Tag 105 would typically use an inexpensive crystal as the frequency source. Even with the limited accuracy of that crystal, the subcarrier frequency could be known to an accuracy of a few Hertz. Thus, very narrowband filters could be used. Since the acknowledge signal response from Tag 105 is used to extend the
10 range of the RFID system and consequently would likely be a very faint signal, it places an additional burden on the narrowband filter of filtering amplifier 210.

Another way that the DSP mentioned above could be used is to dynamically search for the frequency components of the Uplink signal. This could be accomplished by performing a Fourier Transform on the incoming data stream,
15 perhaps using a DSP, or using Processor 200 of FIG. 2. In this manner, the multiple signals representing a modulated subcarrier signal could be differentiated; or, a single subcarrier signal of uncertain data rate could be recovered by using the Fourier Transform to search for multiple signals.

Thus, we have shown how a modulated backscatter communication
20 system can operate in two modes - one in which the backscattered signal is modulated to provide a high data rate Uplink communication channel, and one in which the backscattered channel is modulated with a low data rate signal, perhaps a single tone, to provide an Uplink acknowledgment signal that can be detected at great distances.

25 We now use and extend the above discussion so that several Modes of operation are present, where the different Modes are characterized by different uplink data rates. The first Mode to be discussed here is the "Interrogation Mode." The Interrogation Mode begins with the Interrogator transmitting an Interrogation Signal to the Tag. The Tag receives this Interrogation Signal, decodes it, and
30 determines what actions to take based upon the decoded Interrogation Signal. In a "standard" Interrogation, the Tag would be requested to transmit a particular set of data (called here the Mandatory Data) back to the Interrogator, using the MBS technique discussed above. Each Tag in the reading field of the Interrogator that receives the "standard" Interrogation responds with its Mandatory Data, using a
35 protocol discussed below. The Interrogator also transmits, as part of the "standard" Interrogation Signal, data intended for each and all Tags. Examples of such data include time of day, framing and other synchronization information, etc.

- 12 -

Beyond the "standard" Interrogation, other types of Interrogations are possible as well. For example, the Interrogator, after identifying a specific Tag using the Interrogation Mode, could transmit additional data to that Tag to be stored in the Tag's memory. The Interrogator could also request the Tag transmit other data,
5 stored in the Tag's memory, back to the Interrogator. These additional data communications could be performed at the same data rate used in the "standard" Interrogation. Thus, the Interrogation Mode is used to: transmit commands and data to each and every Tag, identify a specific Tag in the reading field, and also used to communicate in a bi-directional manner with that specific Tag. In the Interrogation
10 Mode, the data rate required in the Downlink is typically not large, since the Interrogation Signal only must contain enough bits to request all Tags in the reading field to respond. Even when significant amounts of Downlink data are transmitted, in many applications this process does not take place frequently and the Downlink data rate is not critical. In the Uplink, the data rate is typically much larger than the
15 Downlink data rate, as the Mandatory Data must frequently be transmitted in the Uplink in a time critical manner. Therefore, in the Interrogation Mode, we have an asymmetry in required data rates in the sense that the Downlink data rate is smaller than the Uplink data rate.

For the second, or Location Mode, the Interrogator transmits an
20 Interrogation Signal to the Tag containing the address of a specific Tag to which this Interrogation Request is directed. In this Mode, the Tag is not requested to respond with the Mandatory Data discussed above. Instead, at least in some embodiments, the requested response is a simple acknowledgment. One embodiment of a simple acknowledgment is a constant-tone signal. Using the narrowband techniques
25 discussed above, a constant-tone signal can be received by the Interrogator at a range far beyond the range of the Interrogation Mode. Therefore, in the Location Mode, we have an asymmetric communications path which has greater data rate in the Downlink than in the Uplink.

We now discuss methods to determine the location of a specific Tag
30 (105). Let us assume that the system currently has no information as to the location of this Tag. Then, an Interrogation Signal is transmitted by all Interrogators, and all Interrogators listen for a response. In one embodiment, each Interrogator can determine the signal strength of the received signal (if any), and those signal strengths can be reported to a central control element. The determination of location,
35 based upon this data, can be done in several ways. The most obvious way is for the control element to determine which Interrogator received the strongest signal strength. Then, the location of the Tag is equal to the location of that Interrogator, to

an accuracy of the effective range of that Interrogator. A more complex method could be implemented if more than one Interrogator received a return signal. Then, given a knowledge of the spatial position of each Interrogator, a refinement on the above positioning could be achieved. For example, if two Interrogators received a
5 return signal, of equal signal strengths, then the Tag's position could be estimated at half way between those two Interrogations. If three Interrogators received a return signal, then a "triangulation" could be performed. It should be apparent that these methods will perform better if there are line-of-sight paths between the Interrogators and the Tag; if the RF communications paths rely on reflections, distorted location
10 results could be obtained. However, it is likely that locations can be determined to an accuracy of the effective range of an Interrogator. Based upon which Interrogator receives the simple acknowledgment, a Location capability can be implemented.

For the third, or Messaging Mode, the Interrogation Signal not only contains the address of a Tag or Tags, but it also may contain data intended for that
15 Tag or Tags. The Tag or Tags whose address matches the Tag address in the Interrogation Signal could be requested to store that data in the Tag's memory, or perform some other function with that data. There are several possible responses to an Interrogation Signal for the Messaging Mode. If the command within the Interrogation Signal requests the Tag to simply store data, then an acknowledgment
20 to indicate successful receipt of the message could be a few bits or even a single bit of information. A single bit of information could be implemented as a constant tone acknowledgment, as mentioned above. Alternatively, if the command within the Interrogation Signal requests the Tag to make a decision, or to transmit other data back to the Interrogator, then the response would be a message consisting of more
25 than a few bits of information. Therefore, in the Messaging Mode, we again have an asymmetric communications path which has greater data rate in the Downlink than in the Uplink.

We observe that the data-rate asymmetry found in the Location and Messaging Modes is similar to the data-rate asymmetry found in a two-way paging
30 system. Paging transmitters (comparable to the Interrogators discussed here) have much greater transmit power than is available in a two-way paging device worn by an individual (the paging device is comparable to the Tags discussed here). Therefore, data rates in two-way paging systems are frequently asymmetric, with greater Downlink data rate than Uplink data rate. The Location and Messaging
35 Modes of the in-building MBS system disclosed here are similar to a two-way paging system, both in technical characteristics and in applications that are supportable.

- 14 -

It is also possible for a transaction that began in one of the above Modes to transition into another Mode of operation. The following is an illustration of the capabilities of the system. Let us assume we wish to communicate with a Tag. A Messaging Mode Interrogation Signal is transmitted from the Interrogator to the Tag, sending data to the Tag, and requesting the Tag to respond with a simple acknowledgment, which is received by the Interrogator. Let us further assume that, based upon the simple acknowledgment received by the Interrogator, the Interrogator wishes to request that additional data, perhaps stored in the Tag's memory, be transmitted back to the Interrogator. In one embodiment, the Interrogator determines the signal strength of the simple acknowledgment signal. If the signal strength is below a certain threshold, then the Uplink data rate is limited to that data rate normally used in the Uplink for the Messaging Mode. If the signal strength is above a certain threshold, then the radio communications path between the Interrogator and this Tag can support communications at the data rate normally used in the Uplink for the Interrogation Mode. If the signal strength is below the threshold, then either data communications can continue, but using the (lower) Uplink data rate of the Messaging Mode, or a messaging could be transmitted to the Tag requesting that the Tag be brought into close proximity to an Interrogator. How that request is received by a human being is described in the above-cited Shober-Protocol application. If the signal strength is above the threshold, then data communications can continue; but using the Interrogation Mode, as discussed above. It should be obvious that, while the above example shows how the Uplink communications could take place at either one of two possible Uplink data rates, it would be possible to extend the above concept to support more than two Uplink data rates.

We now discuss how the three Modes of operation discussed above can coexist in the same system and be operational at the same time. We begin with the realization that these Modes of operation, based upon the required data rates, support different ranges from the Interrogator to the Tag. For example, the Interrogation Mode involves significant data transmission over (relatively) short time periods, such as when an individual walks by an Interrogator. The required data rate is further increased, since there can be several individuals in the reading field at one time. Thus, a protocol (such as Aloha or Slotted Aloha) is required to allow those multiple Tags to respond with their Interrogation data without mutually interfering, thus increasing required data rate. Examples of data rate for communication from the Tag to the Interrogator for the Interrogation Mode range from 50 kbps - 300 kbps. We also note that, in the absence of other factors, range and data rate trade off against each other.

In summary, we have two different "asymmetries" in data rates; greater Uplink than Downlink data rate for the Interrogation Mode, and greater Downlink than Uplink data rate for the Location and Messaging Modes. Thus, the effective range for the Interrogation Mode is smaller than that of the Location or Messaging Modes, because the Uplink data rate requirement is greater in the Interrogation Mode. In the "Narrowband Operation" section above, we disclose how to achieve significant range extension. In that discussion, a Downlink data rate of a few kilobits per second, and an Uplink data rate of a few bits per second, give roughly comparable range. This capability corresponds to the requirements of the Location and Messaging Modes discussed above. For the Interrogation Mode, a Downlink data rate of a few kilobits per second is also adequate, since relatively few bits of data in the Downlink are required, and Uplink data rates are from 50 kbps - 300 kbps. The Downlink range is the same for all three Modes. The Uplink range for the Location and Messaging Modes is roughly the same as the Downlink range. The Uplink range for the Interrogation Mode is much smaller.

Here, we disclose how all three of these modes of operation, Interrogation, Location, and Messaging, can be implemented in and supported by a single, useful, inexpensive end-user device. We call this device a Personal Pager Identifier (PPID). A block diagram of the PPID is shown in FIG. 4.

20 **PPID Description**

The Antenna (401) can be a patch or a loop antenna. The patch antenna has certain advantages for a PPID. The patch antenna can be plated onto the substrate of the PPID device, and the back of the substrate can be a "ground plane" for the patch antenna. This general design will create a antenna "pattern" that is preferentially directed "outwards" - i.e., in directions away from the ground plane. Because of the relatively small size of the PPID - similar in size to an employee badge - and for radio frequency propagation reasons - it is common for RF signals at microwave frequencies to be used. These frequencies, such as 2450 MHz - support very small patch antenna designs (roughly 0.5 inch square).

Therefore, a PPID device, worn as an employee badge, with the patch antenna facing outwards, will optimize radio communications in front of the employee. In this way, when the employee moves towards a doorway with an Interrogator, the Interrogator can establish radio contact with the PPID as soon as possible. As discussed above, the Antenna (401) and Detector Modulator (402) designs are important. The Amplifier (403) design is also important. For the PPID to provide the required Downlink range for the Location and Messaging Modes, the

- 16 -

Amplifier (403) must be able to boost a very weak demodulated AM signal to CMOS levels, operate over a very great dynamic range (because the PPID could be either very close to or very far away from an Interrogator), and draw very little current. Integrated over time, the Amplifier (403) should draw at most a few
5 microamps of current.

The Processor (404) can be a conventional 4 or 8 bit microprocessor as discussed above. The Processor (404) must have a "sleep" mode, in which the current consumption is less than a microamp, and also have an "active" current consumption of far under a milliamp. The role of the Processor (404) is to be the
10 "brain" of the PPID, decoding the Downlink Signals, determining what type of Uplink response is required, etc. The Processor (404) could be clocked from a separate Crystal (430), or from an oscillator contained within the Processor (404).

Data Storage (420) is also present in the PPID. In one embodiment, the Data Storage (420) could be located in the microprocessor, as either volatile or non-
15 volatile storage. In another embodiment, the Data Storage (420) could be located in another integrated circuit, such as a EEPROM. The amount of storage supported in a PPID could range from as little as a few bytes of storage up to tens of thousands of bytes of storage.

The Subcarrier Modulator (405) functions as disclosed in the above-
20 cited Shober-Protocol application, which is hereby incorporated by reference. It is capable of modulating an information signal, of varying data rates, onto a Subcarrier signal which is generated by a Subcarrier Source (406). The Subcarrier Source (406) could be an inexpensive crystal, or it could be a frequency source derived from the main Crystal (430) used to clock the Processor (404).

To display information transmitted to the PPID using the Interrogation
25 Mode or the Messaging Mode, the PPID has a Display (408). To allow the person carrying the PPID to respond to messages, Pushbuttons (407) are also present. A PPID could have one or more than one Pushbuttons (407).

We now observe the similarities between the PPID device as shown in
30 FIG. 4 and other devices on the market today. First, consider an inexpensive "four-function" calculator. Such a calculator consists of a power supply, which could be either a battery or a solar cell; a processor, typically a 4 or 8 bit microprocessor (or ASIC with a microprocessor core); a display, which is typically a glass or plastic liquid crystal display; and pushbuttons to allow numerical inputs and functions to be
35 entered. We note that such a four-function calculator is sufficiently inexpensive today that in many cases these devices are given away as presents, souvenirs, etc.

- 17 -

Next, consider an inexpensive quartz watch. The watch also has a battery, a processor (again, commonly a 4 or 8 bit microprocessor or an ASIC with a microprocessor core), a display, and pushbuttons to allow the correct date and time to be set. Again, such devices are commonly priced below \$10 and are sometimes
5 given away.

In summary, we see that inexpensive devices such as a calculator or a quartz wrist watch already possess many of the elements of a PPID as shown in FIG. 4. The additional components, shown in FIG. 4, are relatively inexpensive; the Antenna (401) is plated onto a substrate and therefore only costs substrate area, the
10 Detector Modulator (402) is a single diode that in volume can be purchased for under \$0.10, the Amplifier (403) can be realized at a cost of under \$0.50, the Subcarrier Modulator (405) can be implemented in a few gates costing a few cents, and the Subcarrier Source (406) can be an inexpensive crystal costing as little as \$0.15 (depending on the frequency of the crystal). Thus, for a total additional cost of as
15 little as \$0.75, a calculator or a quartz watch could have about the same functionality as a PPID.

We now consider the similarities between a Pager and a PPID. The pager already has an antenna (although likely tuned to the wrong frequency), battery, processor, display, and pushbuttons. However, Pagers are more expensive than
20 PPIDs because their radio circuitry, to obtain the range required of a Paging system, is expensive. A two-way Pager -- i.e., a device capable of not only receiving a page but also transmitting a response -- will be even more expensive.

Therefore, the invention disclosed here is not based on taking relatively expensive technology -- like contained within a Pager -- and making it less
25 expensive. This invention is based on starting with inexpensive technology -- such as that present in a calculator or watch -- and adding other inexpensive elements such that the functionality is vastly increased.

One item to mention is that the PPID may require a larger display than that normally available on a calculator or a watch. However, this does not diminish
30 the fact that great additional functionality could be added to what is essentially a very low-cost device, by using modulated backscattered radio technology.

PPID Physical Design

An illustration of a possible PPID design is shown in FIG. 5. The PPID has overall dimensions similar to that of an employee identification badge. The
35 thickness of the PPID depends on the manufacturing techniques used, the type of power supply used, etc. A typical thickness with would likely be about 1/16 inch;

- 18 -

however the technology of "thin electronics" is rapidly advancing.

The Display (501) could be at the top of the PPID. Display (501) is shown with two lines of display; assuming each line presented 10-20 characters, then the total amount of display would be 20-40 characters. This amount of display
5 should be sufficient for most applications. The Employee Photo (502) could be placed below the display; under the photo would be an ideal place for the Antenna (503), which is plated onto the substrate, to be located. To the left of the employee Photo (502) could be the Company Logo (504). Below the Employee Photo (502) and the Company Logo (504) could be the Employee Name (505). Below the
10 Employee Name (505) could be Pushbuttons (506). The Coil (507) could be located beneath the Company Logo (504).

In an alternate embodiment (FIG. 6), the Employee Photo (601) Company Logo (602) are on top, the Employee Name (603) is below, with the Display (604) below the Employee Name (603). The Pushbuttons (605) are at the
15 bottom. As above, the Antenna (606) could be located immediately behind the Employee Photo (601). Above, we discussed the similarity between a four- function calculator and a PPID. It would be straightforward, and add relatively little cost, to add enough Pushbuttons (605) to the PPID so that it will function as a four-function calculator in addition to functioning as a PPID.

20 **Power Management**

An important design parameter for the PPID will be the battery lifetime of the PPID. There are several approaches to the problem of battery life. One approach is for the PPID to provide for a replaceable Battery (409). In this manner the PPID can have a useful lifetime not limited by battery considerations. The
25 disadvantage of having a replaceable Battery (409) is that the PPID may not be water resistant; however watch manufacturers have developed techniques to made water resistant or waterproof watches even with replaceable batteries. Another approach is for the PPID to have a Solar Cell (410) as a power source. This approach has the following limitation: Since PPID operation in low light conditions is just as
30 important as in bright light conditions, the Solar Cell (410) would have to be complemented by an Energy Storage Device (411), which would add cost. The combination of a Solar Cell (410) and an Energy Storage Device (411) could be more expensive than the cost of a replaceable battery.

Another approach is for an Energy Storage Device (411) to be combined
35 with a device to re-charge the Energy Storage Device (411); such a device is a Coil (412). Energy could be inductively coupled and transferred to the Energy Storage

- 19 -

Device (411) through the Coil (412) if the PPID were placed in close proximity to a recharging device with a similar coil operating at a frequency to which the Coil (412) was sensitive.

Another approach, of course, is for a Battery (409) to be built into the
5 PPID at manufacture time and the entire device permanently sealed. This has advantages since the concerns about water damage are not present.

Despite the above alternatives to the problem of providing energy to the PPID, and regardless of which alternative is selected, the PPID must be designed with energy conservation in mind. It is for that reason that concern was discussed
10 above about the electrical current draw of the individual components of the PPID. A final point to mention is that the PPID would be operated in a fashion where the device is not fully functioning at every moment of time. The Processor (404) can have the ability to "go to sleep"; i.e., to enter a state where active processing is not taking place and where the current drain of the processor is quite low. The Processor
15 (404) can also direct the Amplifier (403) to "go to sleep", or to enter a state where Downlink signals cannot be processed and the current drain is also low. Finally, the Processor (404) could decide, if there is no data to be displayed; e.g. if the last message received has been acknowledged, the Processor can halt the operation of the Display (408). Of course, the PPID cannot remain asleep indefinitely, as then it will
20 fail to receive messages and other communications.

There are at least two techniques that can be used to determine when the PPID should be asleep and when it should be awake. First, the Processor (404) could be programmed to wake up at routine intervals (many microprocessors have a watchdog timer for such a purpose). This technique is used by Pagers to allow the
25 device to sleep most of the time. The critical element in this technique is the determination of the length of time the PPID sleeps. To determine this length of time, several factors must be considered. First, the PPID must respond to Interrogation Mode requests as discussed above. Then, the PPID must be awake frequently enough so that, when the PPID enters the reading field of an Interrogator
30 operating in the Interrogation Mode, the PPID can detect the Interrogation Mode signals and properly respond. For example, given an Interrogation Mode range of 30 feet, and a walking speed of 3 feet per second, the PPID must be awake at the very least every 10 seconds, and more likely every 1-3 seconds, to be assured that the Interrogation Mode signals are not missed. Second, the PPID must have a large
35 enough ratio of "total time" divided by "awake time" in order to reduce the current drain enough so that the PPID can be powered by a reasonably small battery, such as a coin cell. This ratio should ideally be as much as 10:1. Third, the PPID must also

- 20 -

not be asleep when Location Mode or Messaging Mode messages are transmitted. It can be assured that the PPID is awake when these messages arrive by designing the overall PPID protocol in conjunction with the frequency that the PPID goes asleep. An example of such a protocol design is shown below.

5 The second technique to assure that the PPID is asleep most of the time is to add an additional element -- an RF Detector (701) -- to the PPID (FIG. 7). The purpose of the RF Detector is to send a signal to the Processor (404) to awaken it whenever the PPID is in the presence of an RF field. If the PPID is not in an RF field; e.g., the PPID has been taken out of the building for the evening, then the PPID
10 would not awaken until the PPID was re-introduced into the building. This would clearly lead to considerable savings in current drain. However, this technique has drawbacks as well. It would be straightforward and relatively inexpensive to design an RF Detector (701) capable of detecting a strong RF field. However, a major advantage of the PPID is that it is capable of detecting weak RF signals, such as
15 those Downlink signals from the Location and/or Messaging modes. A device capable of detecting the presence of a weak RF signal would be essentially as complex as the combination of the Detector (402) diode and the Amplifier (403). This is equivalent to saying that the Detector (402) diode and Amplifier (403) are always awake, but the Processor (404) is asleep until RF signals are heard. This
20 technique may not yield appreciable savings beyond what is possible with the "regular sleep time" technique outlined above. An additional problem with this approach is the following. When the PPID device is brought into a building, since the entire building is covered by at least one Interrogator, the PPID would continually be in an RF field, and thus continually awake. To circumvent this
25 problem would involve a more complex RF Detector (402), which causes the additional problems outlined above. However, for applications in which the PPID is in an RF field only a small percentage of the time, this technique may be preferred.

Authorization and Security

30 There are at least three techniques used for authorization and security in high-security environments. One technique is to check "something you have in your possession", such as an employee badge. Another technique is to check "something you know", which is typically implemented as a password, PIN, etc. Another technique is "something about you", for example a picture, a voiceprint, a fingerprint, a retinal scan, etc.; this data is sometimes called "biometric data."

All three of these techniques can be applied to the use of the PPID. The PPID (400), itself, is the "something you have in your possession." Since the PPID has Pushbuttons (such as 605), it would be possible for the employee to be required to enter a PIN into the PPID in order to, for example, authorize initial building entry, or authorize entry into a particularly high security area. In an alternate embodiment, the employee could use the PPID in the Interrogation Mode to be identified, and then the employee could be required to type in a PIN on a keyboard, for example, located next to the doorway. Thus, the PIN is the "something you know." Finally, the PPID (400) could store the "something about you." With the cost of memory decreasing, it would be possible to have substantial amounts of Data Storage (420) on the PPID (400); for example, 32 kbytes of EEPROM are possible in a single IC. A compressed voiceprint or picture or other such data could be stored in less than 8 kbytes. The PPID (400) would first be identified using the Interrogation Mode discussed above; then the Messaging Mode could be used to request the data be transmitted to the Interrogator. This data could be then compared, using either computer techniques or by a human being, with data taken from the employee; for example from a video camera, microphone, scanning station, etc. This would facilitate an entryway with full security, but without the presence of an on-duty security person dedicated to this entryway. The security person could be located in a central security facility and support multiple entryways.

One additional element of security involves the personal security of the employee in possession of the PPID (400). Let us assume that for some reason this employee encounters an emergency condition. It would be possible for the employee to enter a certain sequence of data in the Pushbuttons (407) that indicate an emergency condition. Depending on the sequence of data entered, additional data concerning the nature of the emergency could also be entered. Upon receipt of the next Downlink Signal, regardless of which Mode, the PPID could transmit a message containing data indicating the fact of the emergency and also, optionally, the nature of the emergency. Thus, the Applications Processor (101) could be alerted, and the proper authorities could be alerted using the Communications Link (130).

PPID Operational Capabilities

We now outline how the PPID (400) could operate. As the employee enters the building, an Interrogator (103) monitoring the entrance to the building establishes radio communications with the PPID through the use of the Interrogation Mode, and optionally transmits data to the PPID such as the time and/or the date so

that the PPID is time-synchronized with the radio communications system. The Interrogator then reports to the Applications Processor (101) the fact that a specific PPID was interrogated, and an interrogation time stamp. Other Interrogators throughout the building regularly transmit Interrogation Mode Signals; when the

5 PPID is in range and receives such a signal, it transmits an uplink signal containing the mandatory data as outlined above. Any other Interrogator (103) that successfully communicates with the PPID through the Interrogation Mode communicates this fact, along with the interrogation time stamp, back to the Applications Processor (101). Therefore, a time history of the location of a specific PPID is built up in a

10 database, called the Location Database (110), in the Applications Processor. Since the effective range of the Interrogation Mode is less than that of the Location and Messaging Modes, the database history of a specific PPID will not be continuous, in the sense that there will be periods of time in which the PPID is not in range of the Interrogation Mode. Therefore, the Interrogation Mode communications have

15 several results. First, the Interrogation Mode is used to authorize initial entrance to the building. Second, the Interrogation Mode could also be used to authorize entrance to other doorways in the building, such as secure areas, etc.; the Interrogation Mode could also be used to authorize entrance to the employee's office door. Third, the use of the Interrogation Mode by Interrogators throughout the

20 building allows a time history, albeit not continuous, of the approximate location of a specific PPID.

Let us assume that the Location of a specific PPID (400) is desired. A request for such a location is transmitted to the Applications Processor (101) over a Communications Link (130), which could be connected to the LAN, as shown in

25 FIG. 1, or alternately could be connected directly to the Applications Processor (101). The Applications Processor (101) first checks the Location Database (110) to determine whether the location of the PPID (400) was recently obtained. If no recent determination of location was made, then the Applications Processor (101) determines that the location of this PPID is unknown, and a Location Mode Signal is

30 transmitted by all Interrogators, requesting the PPID to respond. If the location of the PPID was recently determined, then in one embodiment only Interrogators (103) in the vicinity of this previously determined position could transmit a Location Mode Signal addressed to this specific PPID (400). Then, the Interrogators (103) transmit to the Applications Processor (101) the results of the Location Mode Signal;

35 whether a response signal was detected, and if so, the signal strength of that signal. The Applications Processor (101) can then determine the approximate location of the PPID and return that information to the requester over the Communications Link

(130).

Let us assume that a message is desired to be transmitted to a PPID (400). The Applications Processor (101) receives such a request over the Communications Link (130), and stores the message to be transmitted to the appropriate PPID in the Messaging Database (120). The Applications Processor then checks the Location Database (110) to determine whether the location of the PPID (400) was recently obtained. If no recent determination of location was made, then the Applications Processor (101) determines that the location of this PPID is unknown, and a Messaging Mode Signal is transmitted by all Interrogators. If the location of the PPID (400) was recently determined, then in one embodiment only Interrogators (103) in the vicinity of this previously determined position could transmit a Messaging Mode Signal addressed to this specific PPID (400). The PPID (400) receives the Messaging Mode Signal, and responds with an acknowledgment message, using MBS, to the Interrogator. Thus, the "session" in this example consists only of the Downlink Messaging Mode Signal and the Uplink acknowledgment message. The Interrogator that receives the acknowledgment message reports this to the Application Processor (101), which marks this message in the Messaging Database (120) as having been delivered.

Let us assume that data is desired to be received from a specific PPID (400). The Applications Processor (101) receives such a request over the Communications Link (130), and stores the request in the Messaging Database (120). The Applications Processor then checks the Location Database (110) to determine whether the location of the PPID (400) was recently obtained. If no recent determination of location was made, then the Applications Processor (101) determines that the location of this PPID is unknown, and a Messaging Mode Signal is transmitted by all Interrogators. If the location of the PPID (400) was recently determined, then in one embodiment only Interrogators (103) in the vicinity of this previously determined position could transmit a Messaging Mode Signal addressed to this specific PPID (400). The PPID (400) receives the Messaging Mode Signal, and responds with an acknowledgment message, which acknowledges receipt of the Messaging Mode Signal. This transaction establishes the "session". The Interrogator (103) measures the signal strength of the acknowledgment message, and based on this signal strength, determines what Uplink data rate can be supported to this Tag. Communications could be supported at a low data rate (for optimum range), or at a high data rate (for optimum data rate), depending on Uplink signal strength. The Interrogator (103) transmits another Messaging Mode Signal to the PPID (400), instructing the PPID which Uplink data rate to use in transmitting the

- 24 -

required data. After this data is transmitted, this marks the end of the "session". After the required data has been received by the Interrogator (103), the Interrogator transmits the data to the Application Processor (101), which then transmits the data over the Communications Link (130). In an alternative embodiment, the
5 Applications Processor (101) stores the data in the Messaging Database (120) in the event the data is required later or in the event that the transmission over the Communications Link (130) fails.

Let us assume that data is desired to be transmitted to, and also received from, a specific PPID (400). Given the above discussion, it should be clear how both
10 of these functions could be incorporated into the same "session" between an Interrogator and a Tag.

Based on the Messaging Mode capability, the PPID (400) could be transmitted data, not for storage in the Data Storage (420) module, but for display on the Display (408). For example, the Application Processor (101) could be requested,
15 through communications over the Communications Link (130), to transmit a message to a particular PPID (400) that the employee has received an urgent telephone call or an urgent electronic mail message. Notification of the receipt of such a call or electronic mail message could be displayed on the Display (408). It may be helpful for the PPID (400) to alert the employee that a new message is being
20 displayed on the Display (408). The PPID (400) could have an Alert Device (413) built in, which could be a buzzer (or other such sound maker) or vibrator.

An extension of the above Messaging Mode scenario involves sending a message to a specific PPID (400), having that message displayed on the Display (408), and requesting the employee to enter an acknowledgment into the PPID (400)
25 indicating that the employee saw the message. The acknowledgment could, e.g., be entered by pressing a specific Pushbutton or Pushbuttons (407). This would allow the Applications Processor (101) to be certain that a critical message was received.

In a high security environment, additional precautions can be taken. One technique is as follows. The Interrogation Mode is used to identify the PPID
30 whose employee is requesting access to a specific entryway. As discussed above, the Messaging Mode is then used to request that data be transmitted back to the Interrogator. If the required data is a PIN, then the employee must enter the PIN into the PPID's (400) Pushbuttons (407); this PIN is then transmitted back to the Interrogator. If security of the PIN is an issue, that communication could easily be
35 encrypted. In the event that "something about you" was stored in the Data Storage (420) of the PPID (400), the Messaging Mode could be used to request that data be transmitted from the PPID to the Interrogator (103), and then transmitted to the

Applications Processor (101).

There are times in which the employee will not want to be located. The PPID (400) could be instructed, perhaps by the employee entering specific data into the Pushbuttons (407), to only respond to certain of the Modes of operation, or
5 alternately to not respond to any of the Modes of operation. For example, the employee could use the PPID (400) to gain access to the building, but then disable the PPID (400) in this manner.

In a security environment, however, employees surrender some elements of personal privacy. If the employee disables the PPID (400), then the employee
10 forfeits the ability to enter other controlled access entryways. Further, let us assume that we wish to monitor an entryway to assure ourselves that a person does not move past that spot without a valid PPID (400) being read. It is possible to incorporate a motion detection system to the RFID system discussed here. In addition, it is possible to incorporate motion detection capability into the Interrogator (103)
15 described here, with the addition of a Motion Detector (220), which detects Doppler shifted signals in the audio frequency range. Therefore, an Interrogator (103) could be configured to return an alarm to the Applications Processor (101) in the event that motion was detected but no PPID (400) was read.

Finally, in some very high security applications, it may be required for
20 the Applications Processor (101) to "override" the ability of the employee to disable the PPID (400). For example, assume the three Modes of operation have two command types; "System" level commands and "User" level commands. This is similar to certain commands on a computer system requiring different levels of authorization. The disabling of the PPID (400) by use of the Pushbuttons (407)
25 would not deactivate the PPID fully; but rather, could set the PPID in a mode where it only responded to "System" level commands and not to "User" level commands. This distinction could be very helpful in a building environment in which certain parts of the building were at a much higher level of security than others; the "User" level commands could be used in areas of lower level of security, and the "System"
30 level commands could be used in areas of high level of security.

Among the methods of powering the PPID discussed above, two methods were an Energy Storage Device (411) and a Coil (412). These methods could be used together as follows. Assume that a Docking Station (800, FIG. 8) was developed. The PPID (400) would be placed on top of the Docking Station (800)
35 when the Energy Storage Device (411) required charging. The Coil (412) of the PPID (400) would be oriented so that it was directly on top of a similar Coil (801) in the Docking Station (800). Thus, the Energy Storage Device (411) could be re-

- 26 -

charged. Another helpful use of the Coil (412) would be to power the PPID (400) in the event that the Energy Storage Device (411), the Battery (409), or whatever method of powering was used failed to operate. This would allow the data in the PPID (400) to be recovered even in the event of such failure.

5 What has been described is merely illustrative of the application of the principles of the present invention. Other arrangements and methods can be implemented by those skilled in the art without departing from the spirit and scope of the present invention.

The invention claimed is:

1. A communication device, comprising:
 - a demodulator of received modulated radio signals, operable for recovery of at least one First Information Signal;
 - 5 a first decision element, responsive to the First Information Signal, adapted to provide an output that indicates a selected one of at least two alternative actions, to be referred to as Action A and Action B;
 - a display device adapted to display at least a portion of the First Information Signal;
 - 10 a signal-generating device adapted to generate a Second Information Signal in response to the output of the decision element, wherein the Second Information Signal has a data rate, and said data rate is greater when Action A is indicated than when Action B is indicated; and
 - a backscatter modulator adapted to modulate reflections of the received modulated radio signals, using the Second Information Signal.
 - 15

2. The device of claim 1, further comprising:
 - a subcarrier signal generator; and
 - a modulator adapted to modulate the subcarrier signal with the Second Information Signal, thereby to form a modulated subcarrier; and wherein:
 - 20 the backscatter modulator is adapted to modulate reflections of the received modulated radio signals with the modulated subcarrier.

3. The device of claim 2, wherein the modulator is responsive to the first decision element, such that the modulated subcarrier for Action B is a pure unmodulated tone at the frequency of said subcarrier.

- 25 4. The device of claim 1, further comprising at least one pushbutton, and wherein the signal-generating device is response to said at least one pushbutton, such that at least some contents of the Second Information Signal are determined, at least in part, by depression of at least one said pushbutton.

5. The device of claim 1, further comprising:
 - 30 at least one pushbutton; and
 - a second decision element adapted to provide an output that indicates whether the Second Information Signal should be transmitted; and wherein:

- 28 -

the second decision element is responsive to at least one said pushbutton such that depression of at least one said pushbutton leads to an indication that the Second Information Signal should be transmitted.

5 6. The device of claim 1, further comprising an alarm, and means for activating the alarm based upon contents of the First Information Signal.

7. The device of claim 1, further comprising a storage medium for storing at least a portion of the First Information Signal.

10 8. The device of claim 1, further comprising means for generating at least a portion of the Second Information Signal from data stored within said communication device.

9. The device of claim 1, further comprising a stored record of biometric data pertaining to a holder of said communication device, and wherein the signal-generating device is adapted to include at least some of said data in the Second Information Signal.

15 10. The device of claim 1, further comprising:
 an energy-transfer element; and
 an energy-storage element that is rechargeable through the energy-transfer element.

20 11. The device of claim 10, wherein the energy-transfer element comprises a coil.

12. The device of claim 10, wherein the energy-storage element comprises a capacitor.

13. The device of claim 1, further comprising a solar cell and an energy storage device chargeable from the solar cell.

25 14. The device of claim 1, further comprising:
 a signal processor having a sleep mode and a waking mode; and

means for regularly awakening the processor from the sleep mode.

15. The device of claim 1, further comprising:

a signal processor having a sleep mode and a waking mode; and
a radio-frequency (RF) detector; wherein:

5 the signal processor is responsive to the RF detector such that when the presence of an RF field is detected, the signal processor is awakened from the sleep mode.

16. The device of claim 1, further comprising:

a graphic; and

10 an antenna at least partially situated beneath the graphic.

17. The device of claim 1, further comprising:

a graphic; and

an energy transfer device at least partially situated beneath the graphic.

18. The device of claim 16 or claim 17, wherein the graphic is a picture

15 of a holder of said communication device.

19. The device of claim 16 or claim 17, wherein the graphic is a

company or organizational logo.

20. The device of claim 1, further comprising:

a plurality of pushbuttons constituting a mathematical keyboard; and

20 a microprocessor in receiving relationship to the pushbuttons, the microprocessor adapted to perform at least some mathematical operations in response to manipulations of the pushbuttons, and to display results of such operations on the display device.

21. The device of claim 1, further comprising:

25 at least one pushbutton for designating an emergency mode; and means, responsive to the pushbutton, for executing an emergency mode upon receipt of the next First Information Signal after an emergency mode has been designated; wherein:

- 30 -

the signal-generating device is responsive to the emergency-mode executing means, such that when the emergency mode is executed, a Second Information Signal is generated containing data indicating an emergency condition.

FIG. 1

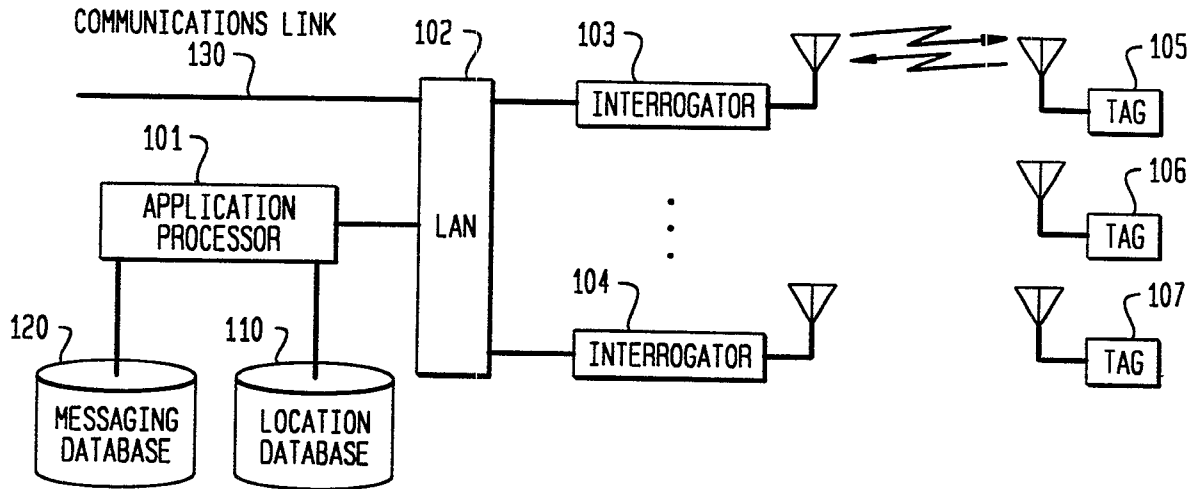
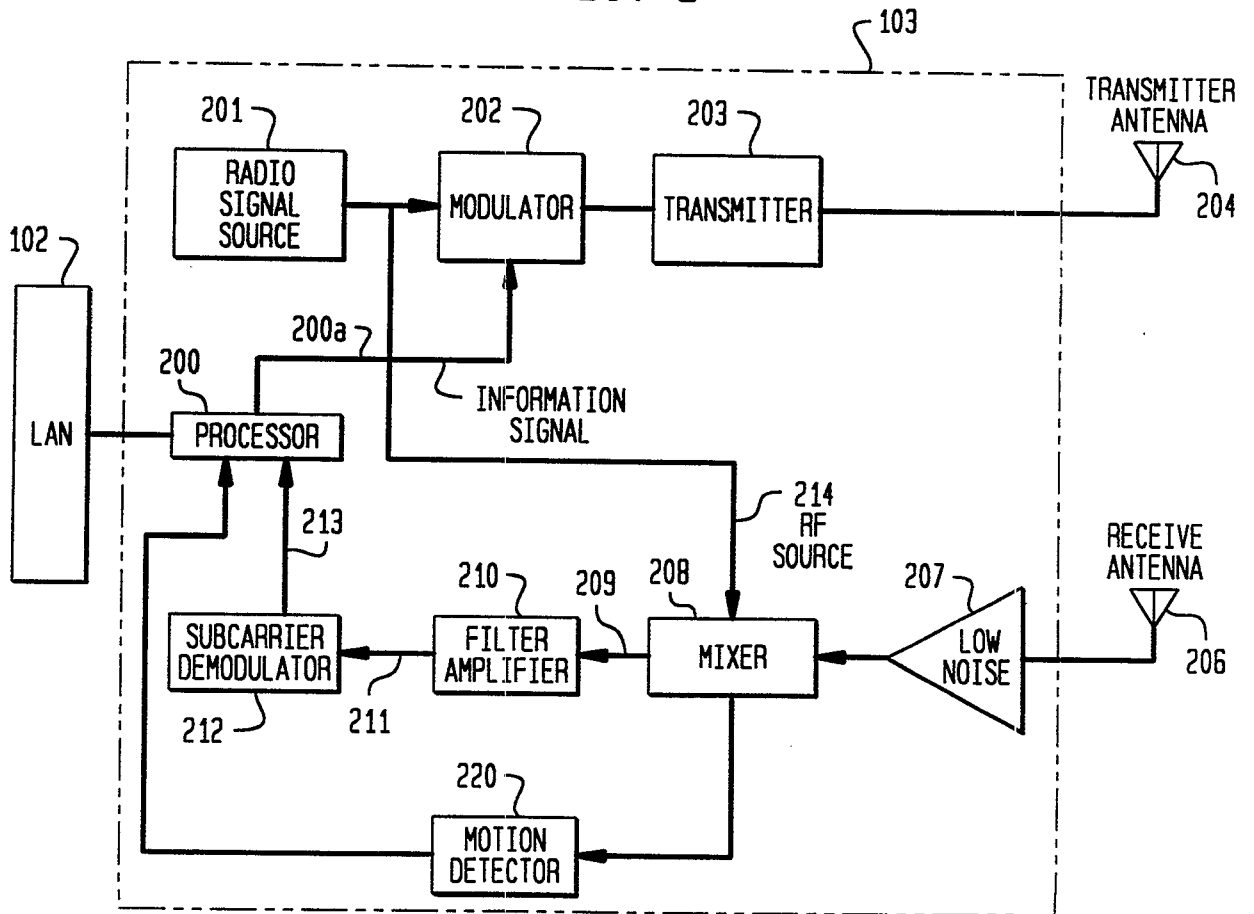

FIG. 2



2/4
FIG. 3

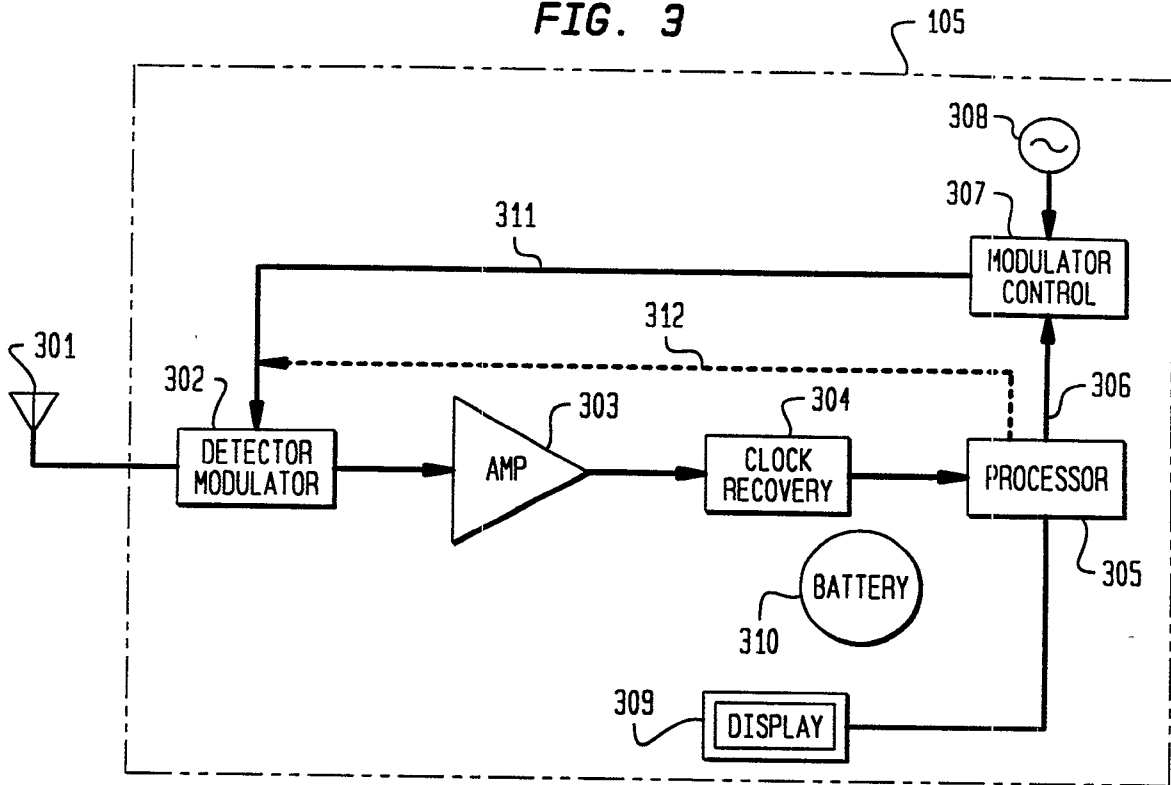
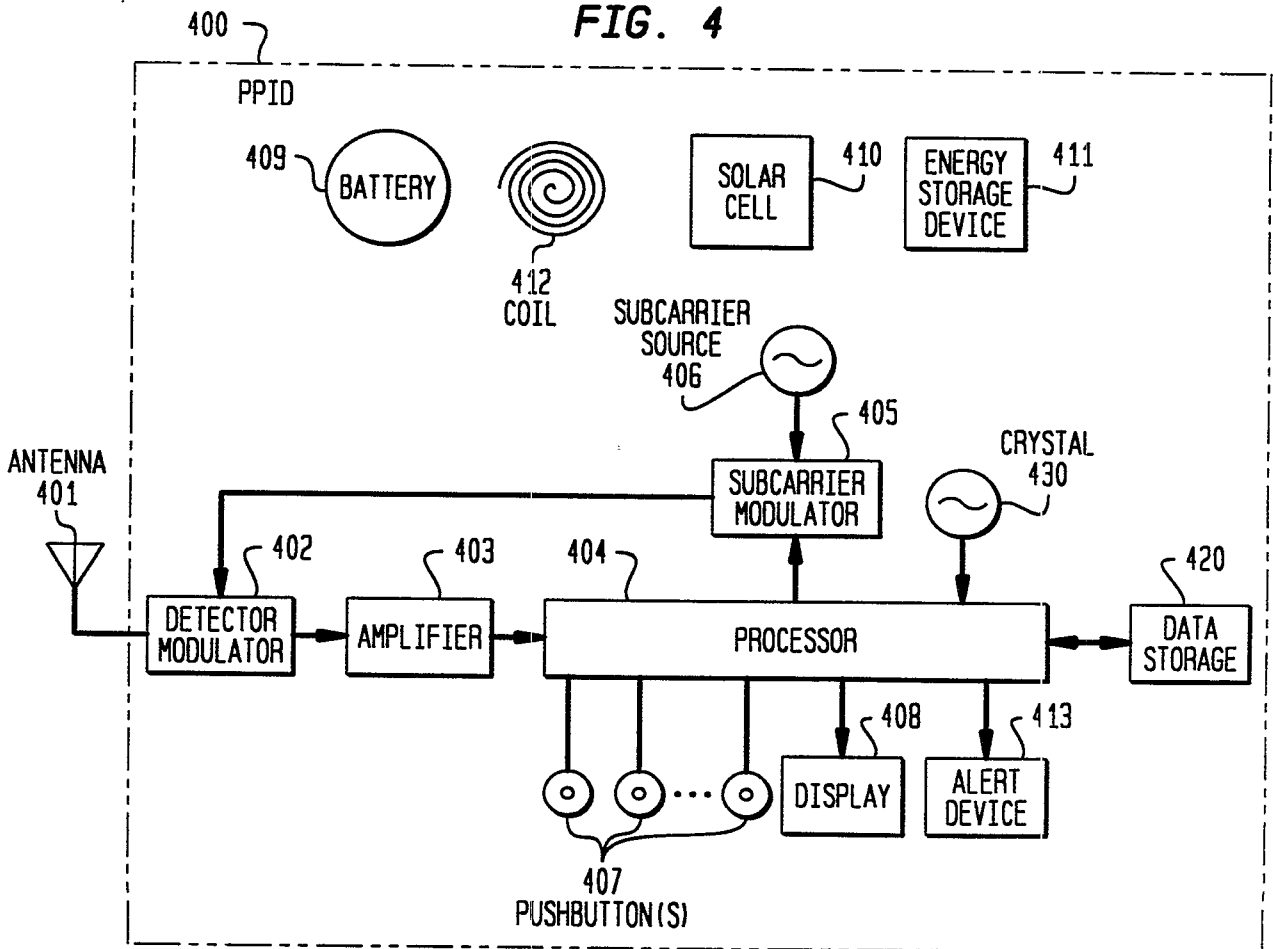

FIG. 4



3/4

FIG. 5

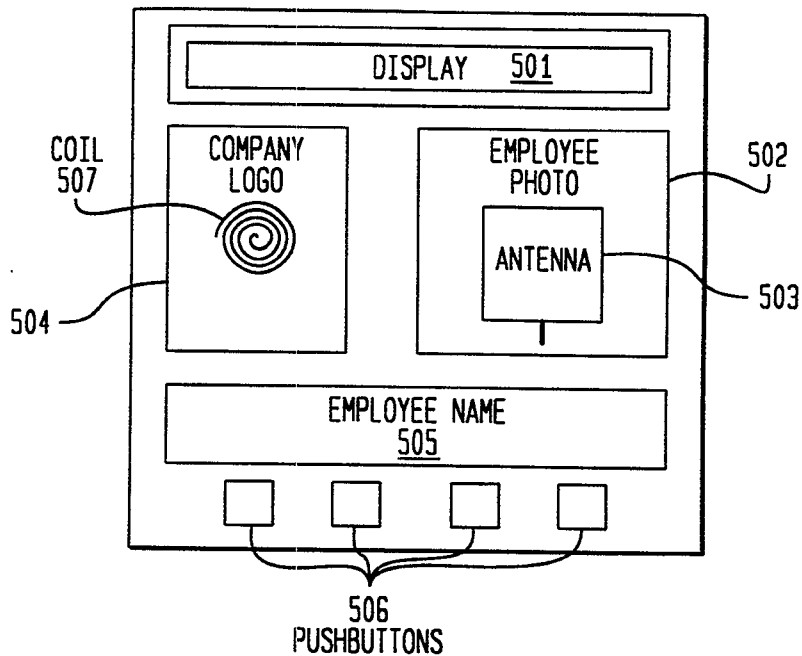

FIG. 6

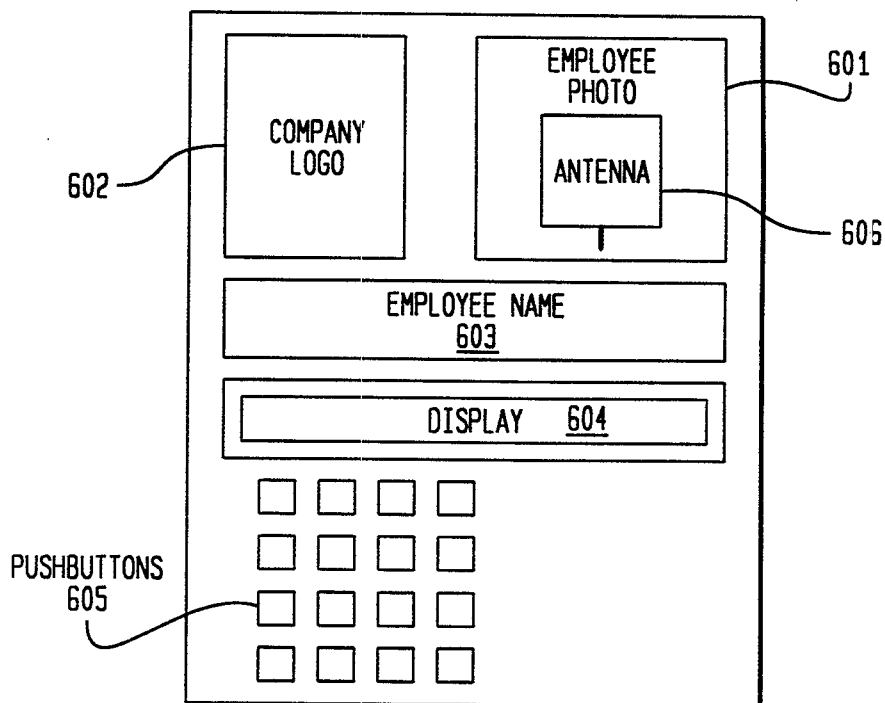

FIG. 7

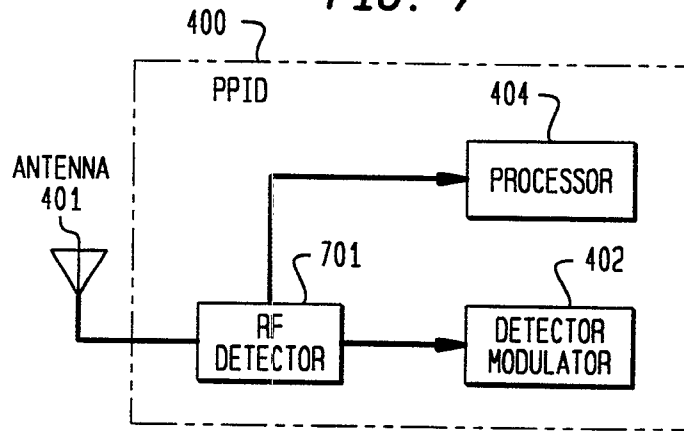

FIG. 8

