



(19) **United States**

(12) **Patent Application Publication**

Kamisuwa et al.

(10) **Pub. No.: US 2004/0174576 A1**

(43) **Pub. Date: Sep. 9, 2004**

(54) **COLOR SIGNAL COMPENSATION**

Publication Classification

(76) Inventors: **Yoshikatsu Kamisuwa**, Kawasaki (JP); **Koji Tanimoto**, Tagata (JP); **Jun Sakakibara**, Tokyo (JP); **Kunihiko Miura**, Hiratsuka (JP)

(51) **Int. Cl.7** **H04N 1/40; G03F 3/08**

(52) **U.S. Cl.** **358/514; 358/518; 358/461**

Correspondence Address:
SOCAL IP LAW GROUP
310 N. WESTLAKE BLVD. STE 120
WESTLAKE VILLAGE, CA 91362 (US)

(57) **ABSTRACT**

Methods and apparatus for color signal compensation are disclosed. A quality of one type of signal is enhanced using a second type of signal, wherein the second type of signal has a higher quality than that of the unenhanced first type of signal. This may be used in an image forming apparatus for scanning a color image, and using higher-resolution monochrome signals to enhance the resolution of lower-resolution color signals.

(21) Appl. No.: **10/791,590**

(22) Filed: **Mar. 2, 2004**

Related U.S. Application Data

(60) Provisional application No. 60/452,338, filed on Mar. 5, 2003.

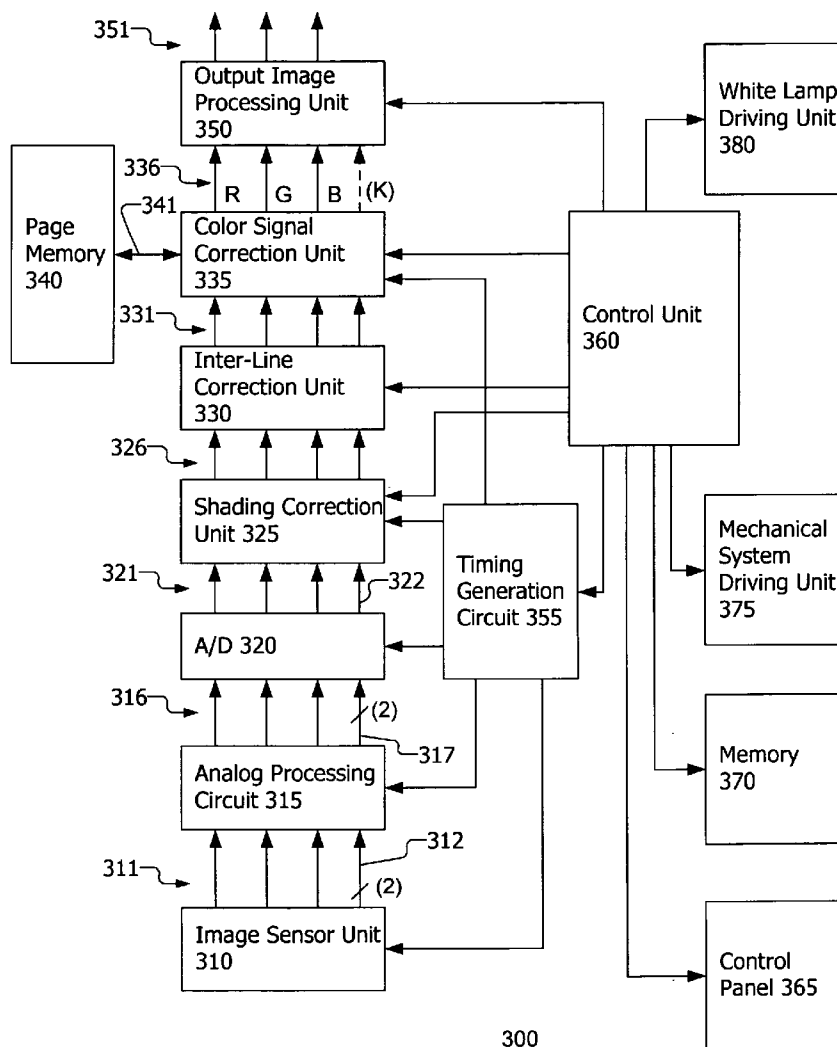

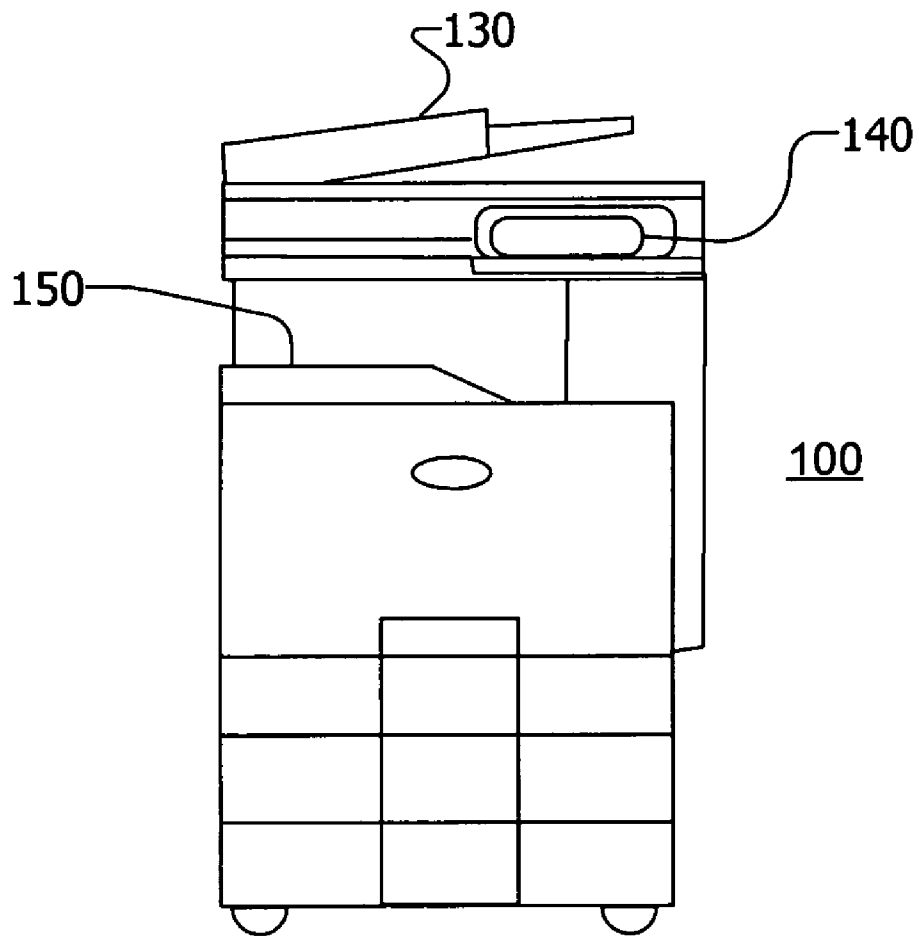

FIG. 1

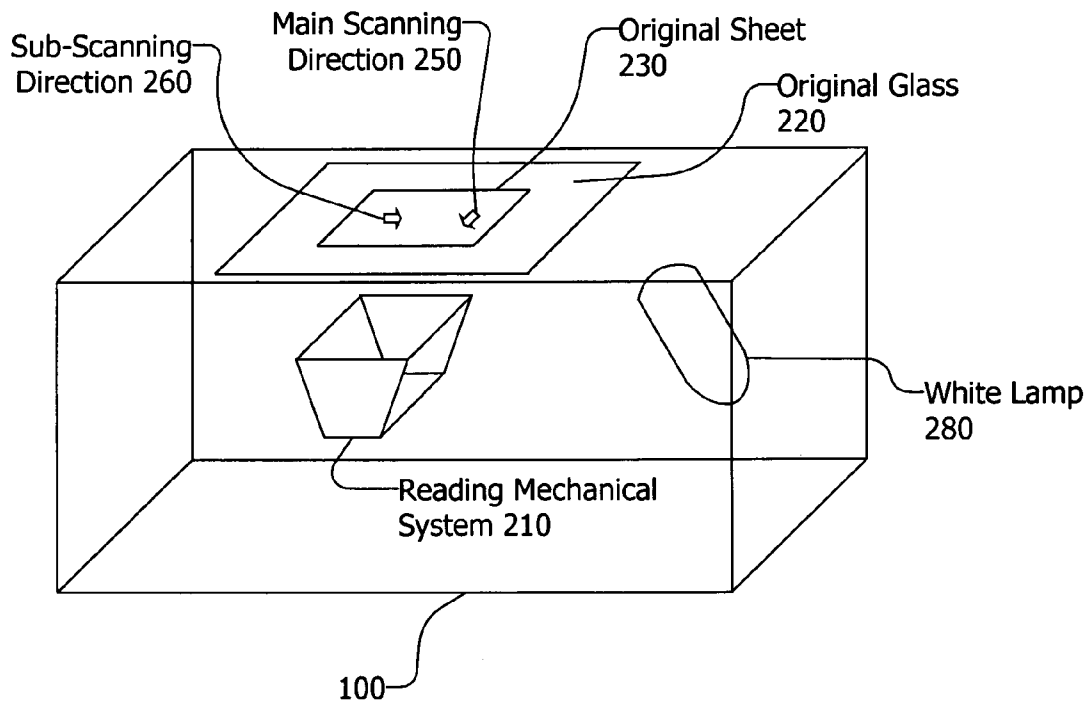
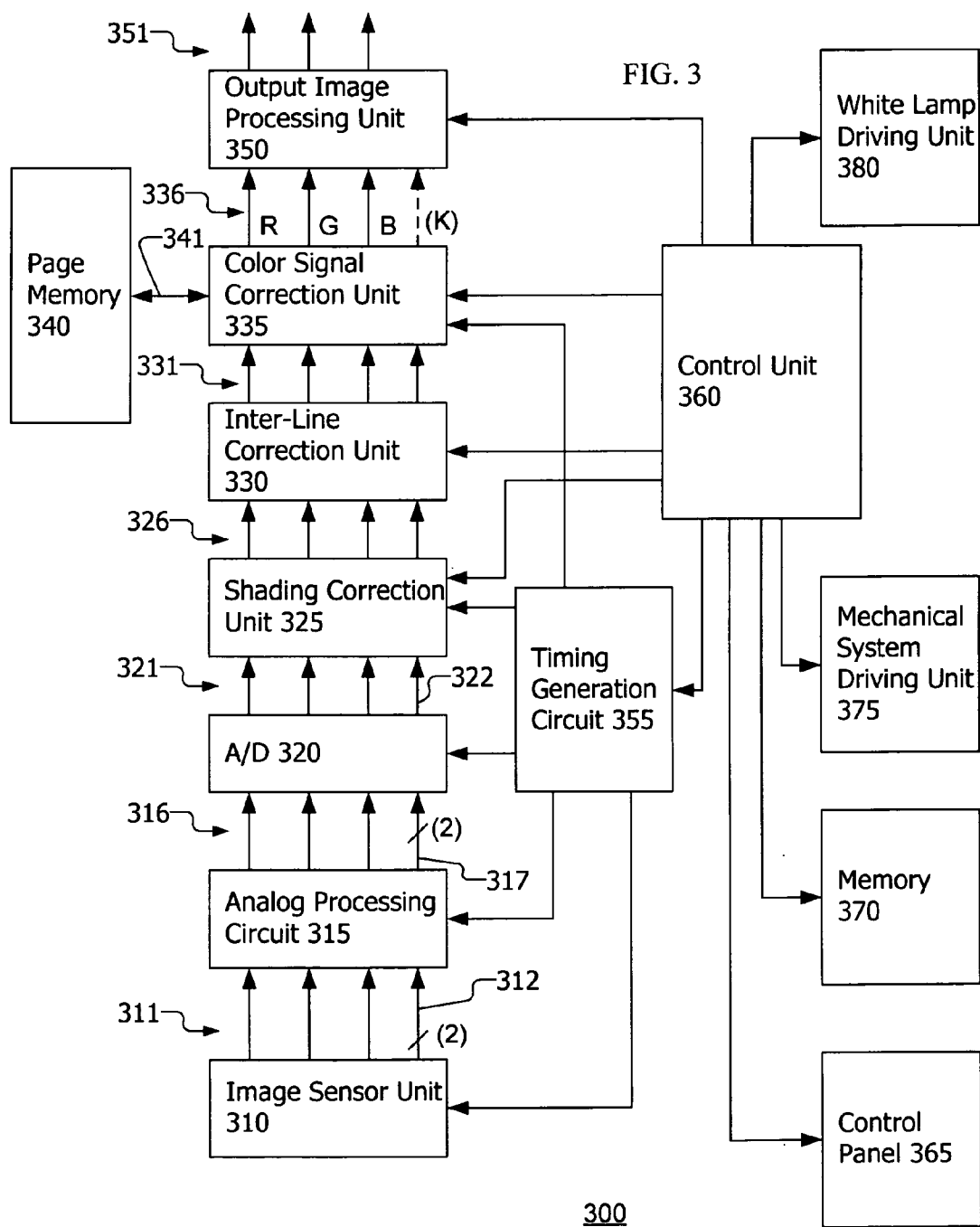

FIG. 2



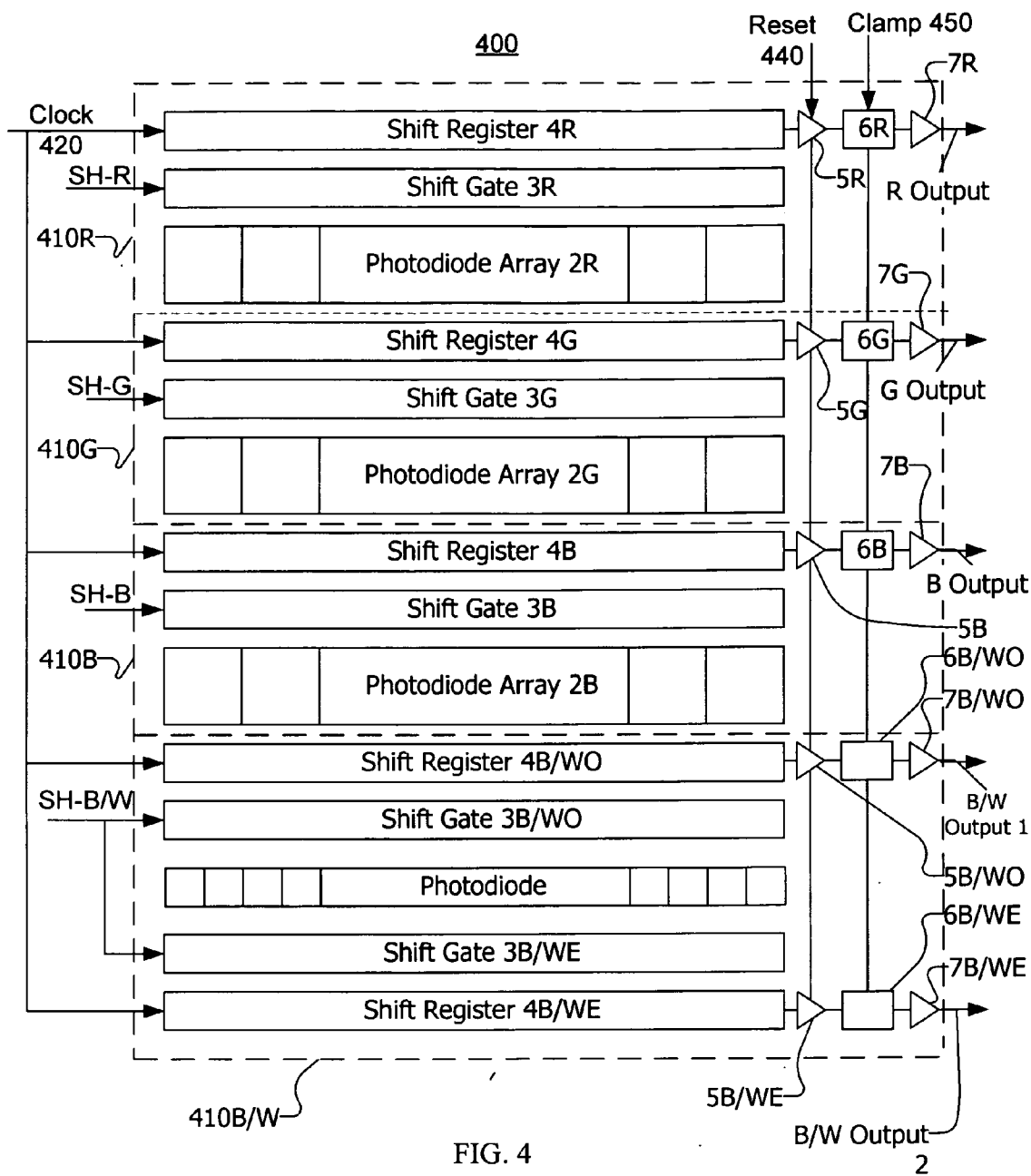

FIG. 4

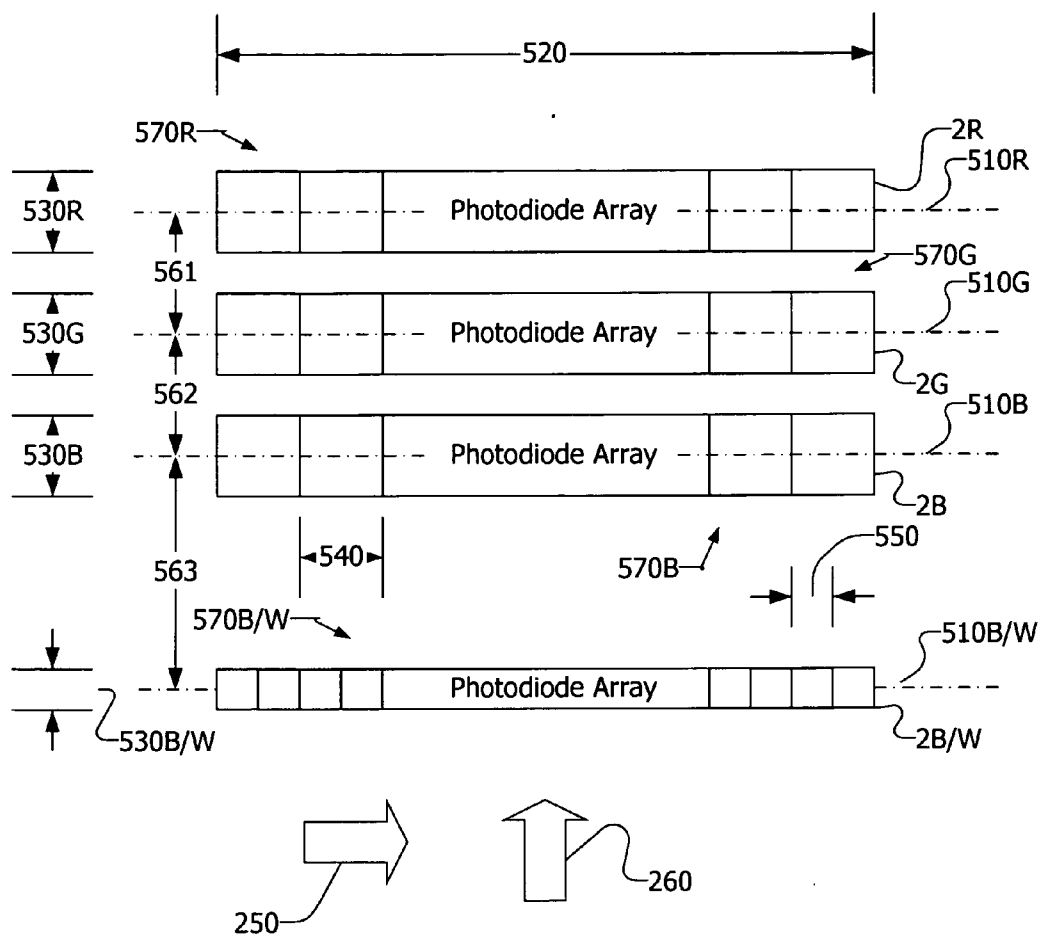

FIG. 5

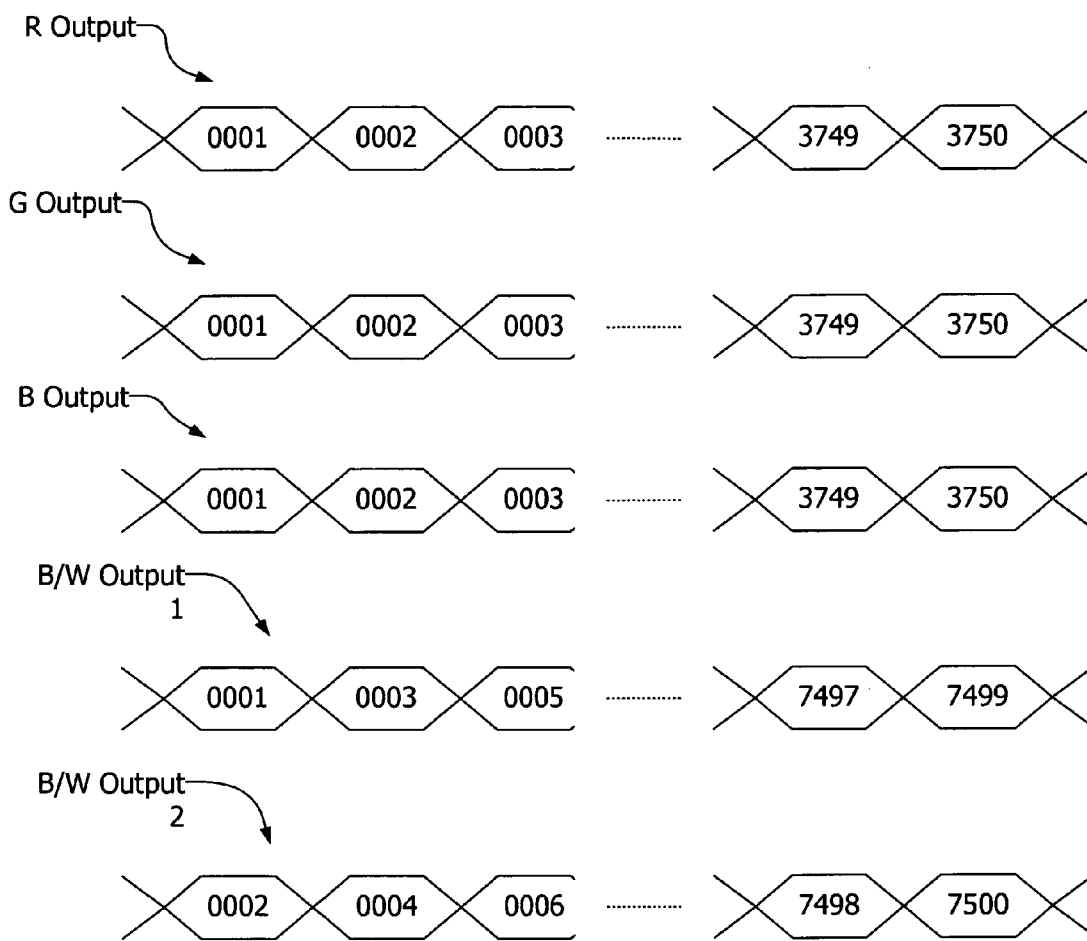

FIG. 6

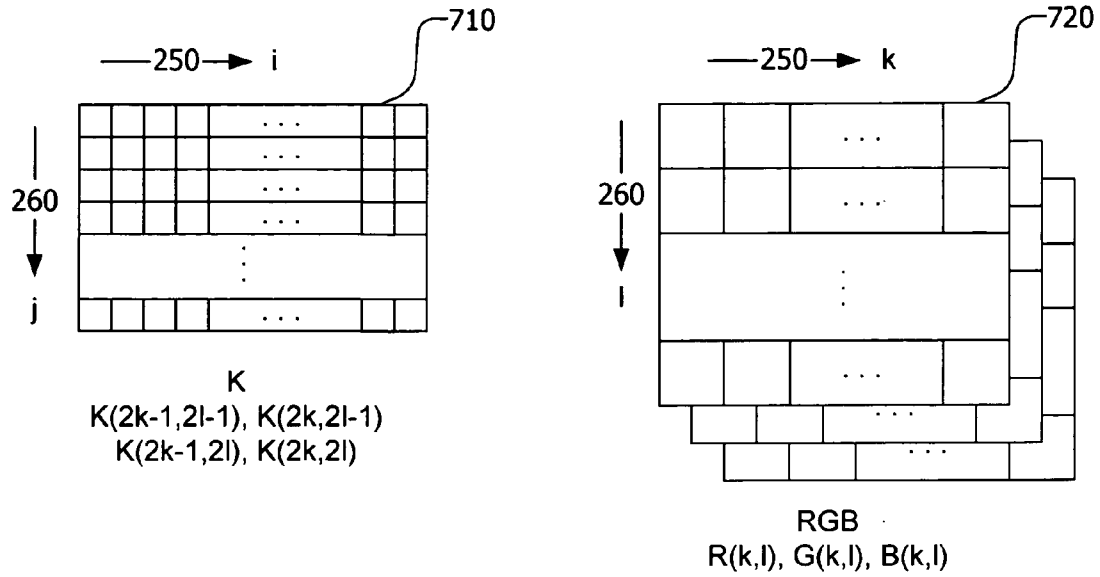

FIG. 7

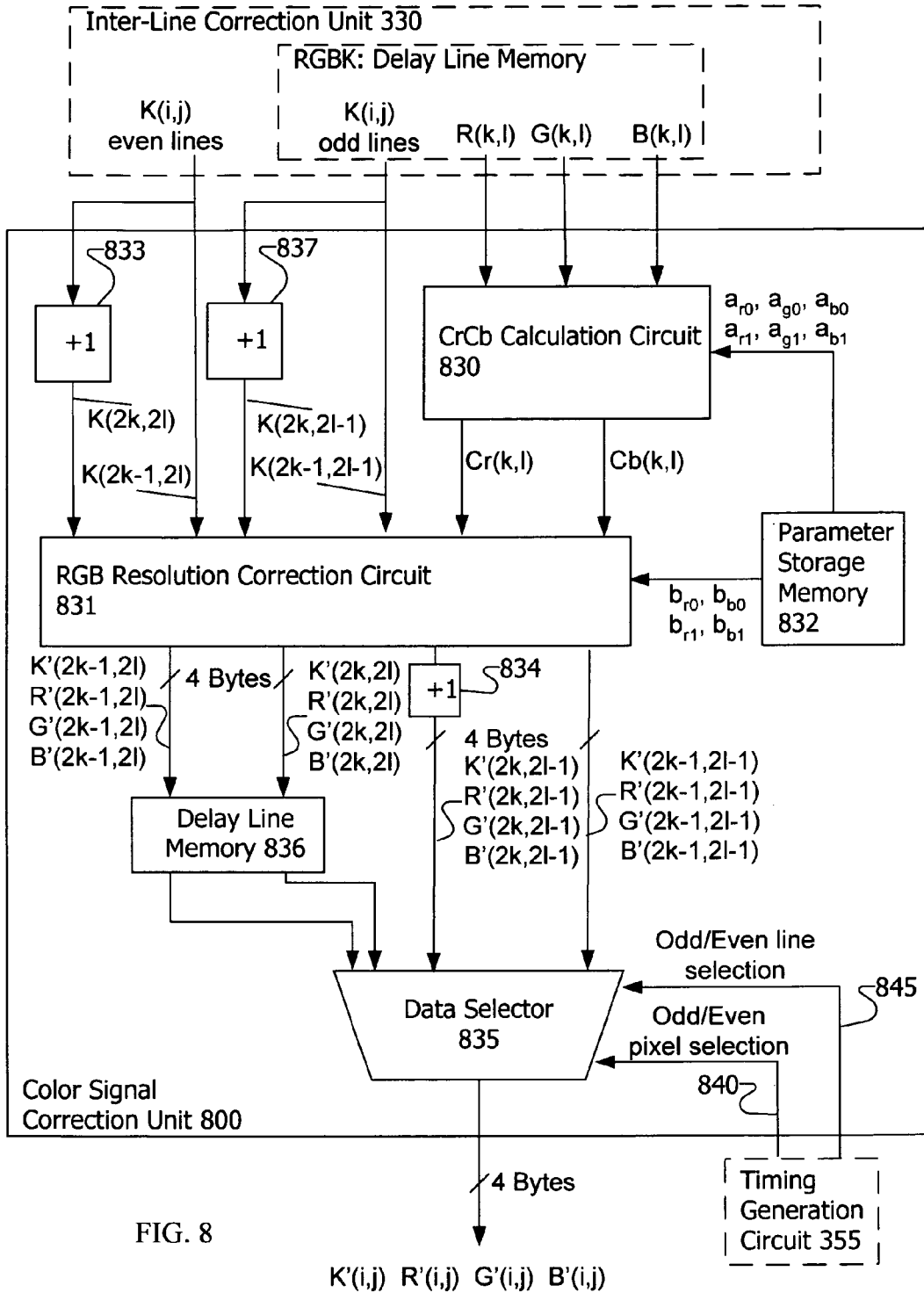

FIG. 8

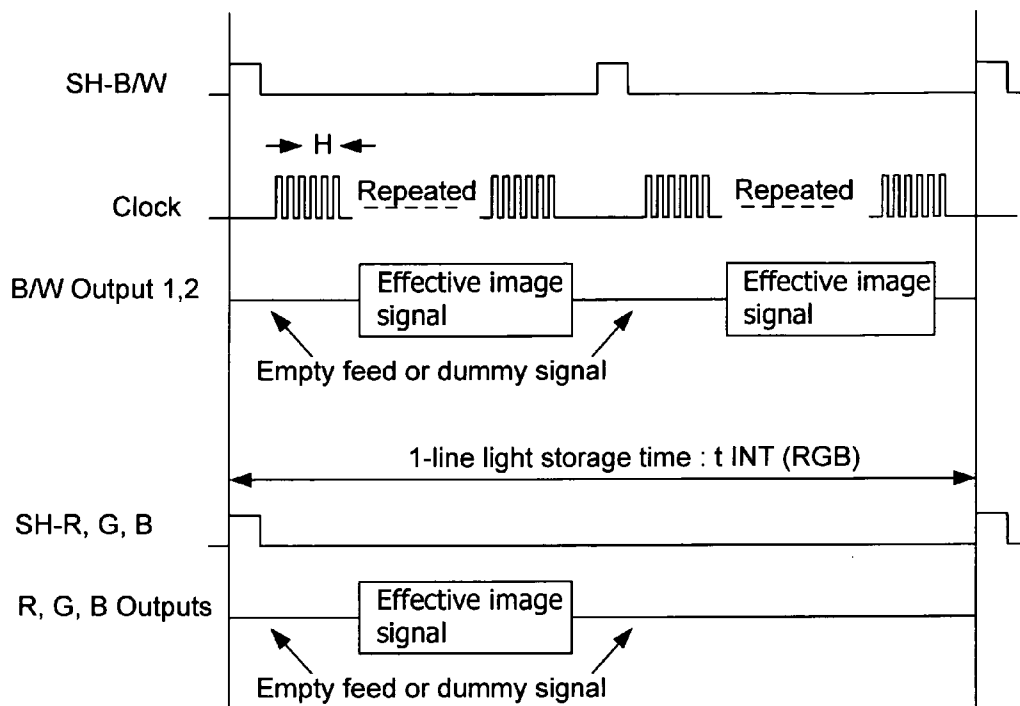

FIG. 9

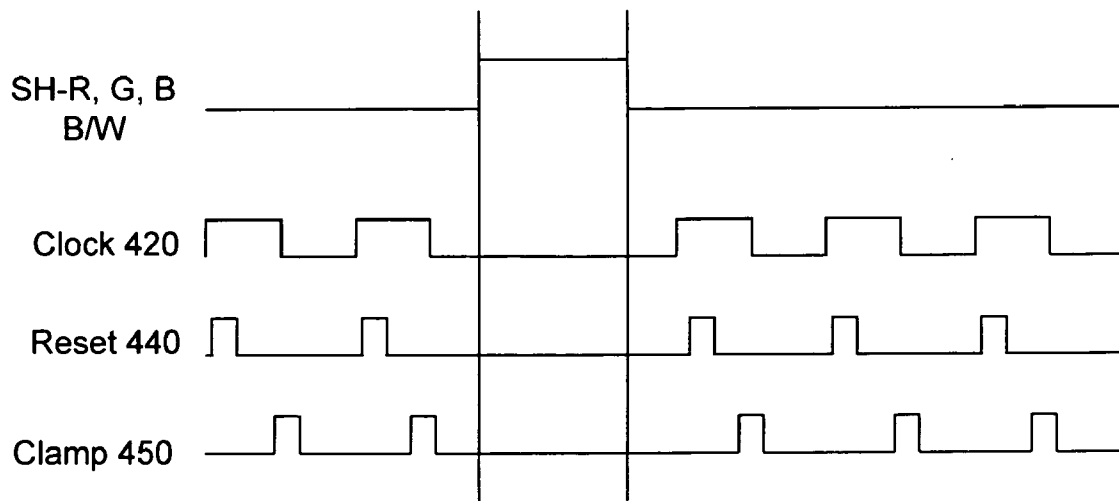

FIG. 10

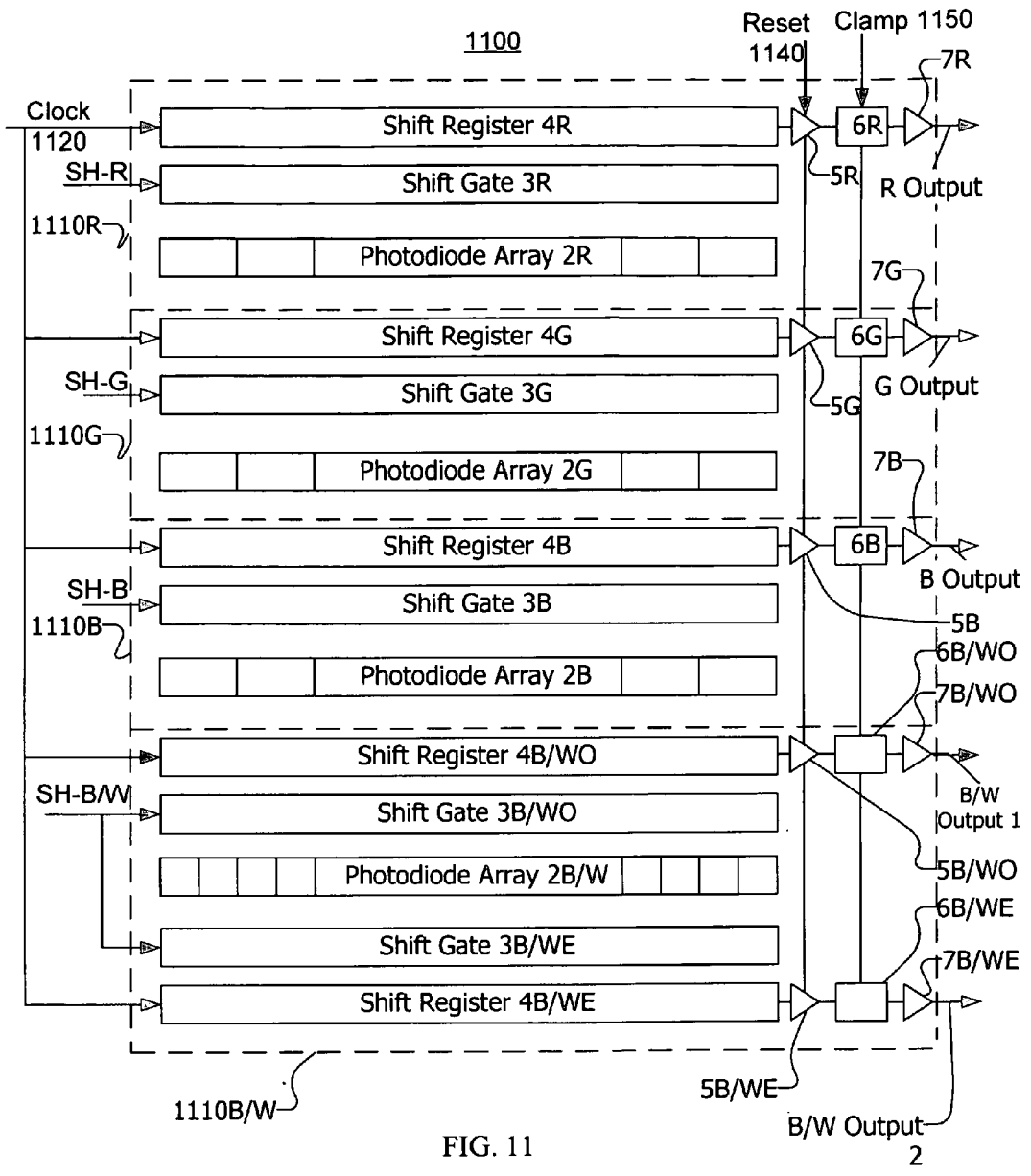

FIG. 11

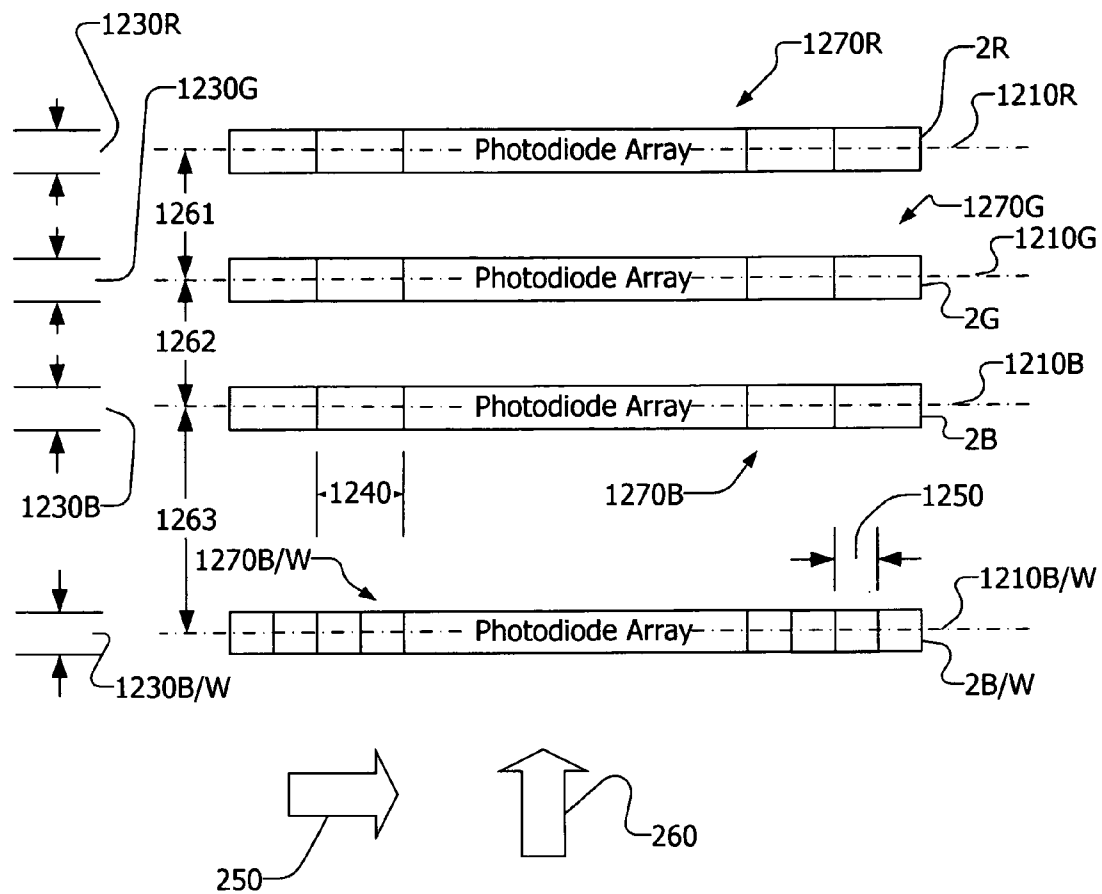

FIG. 12

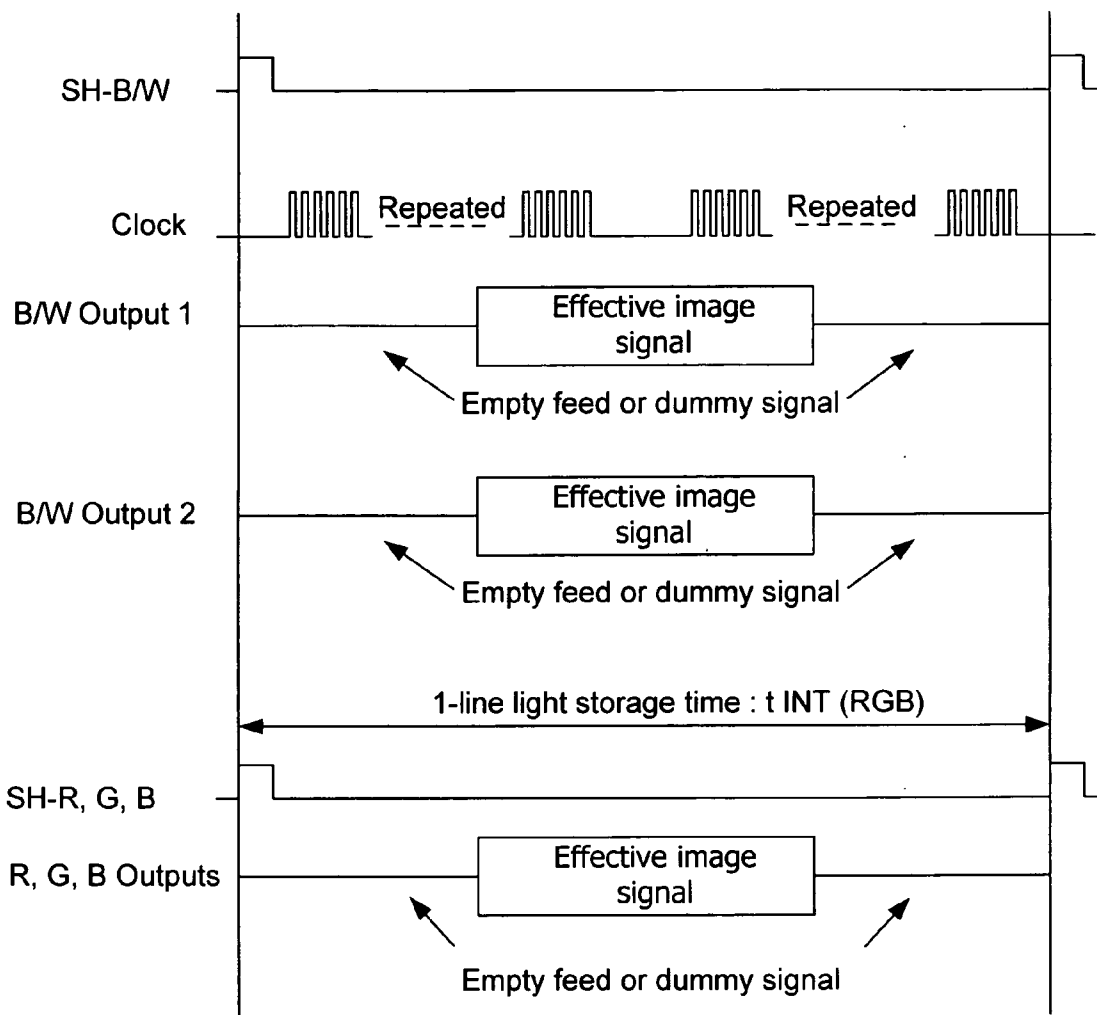

FIG. 13

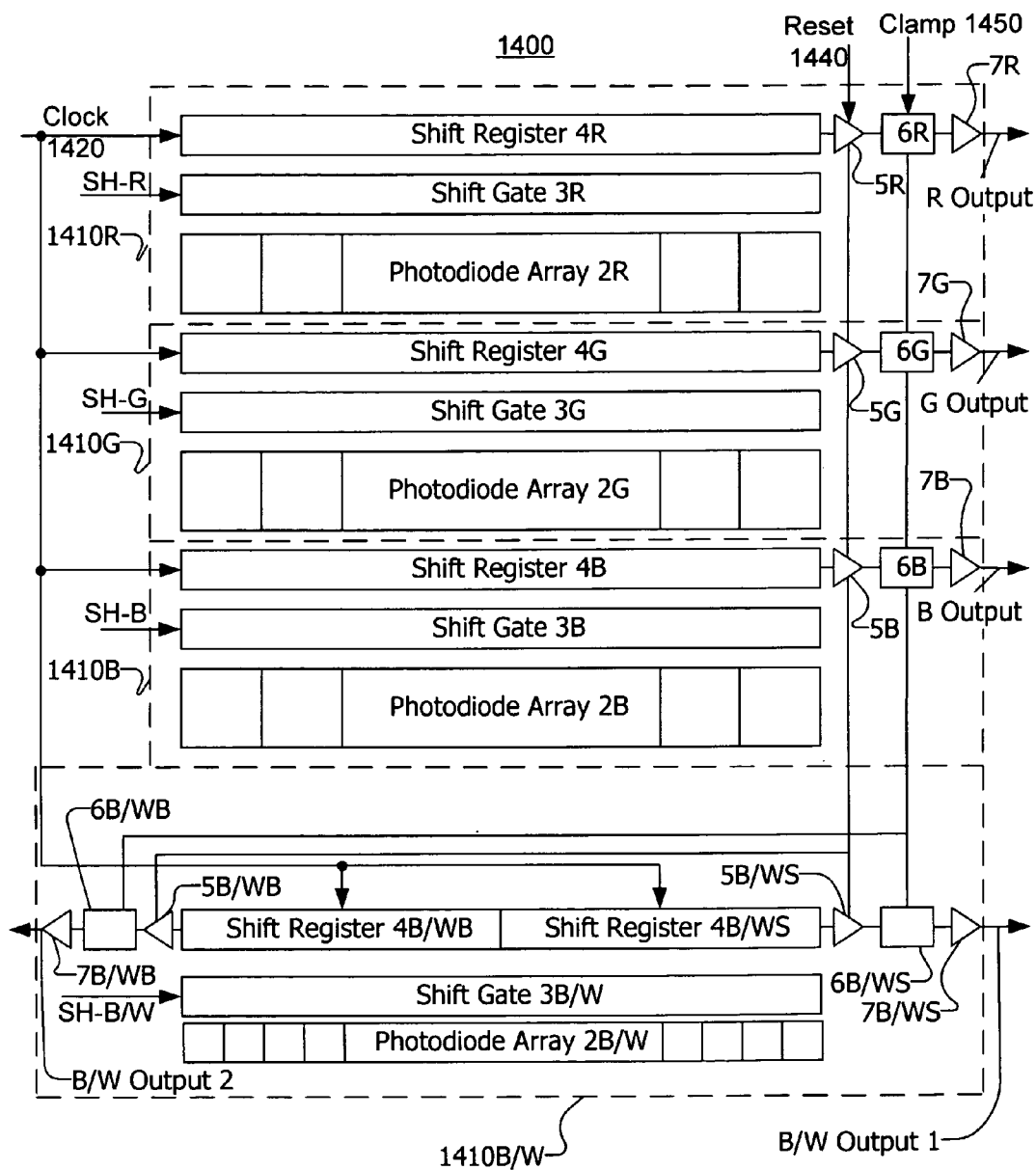

FIG. 14

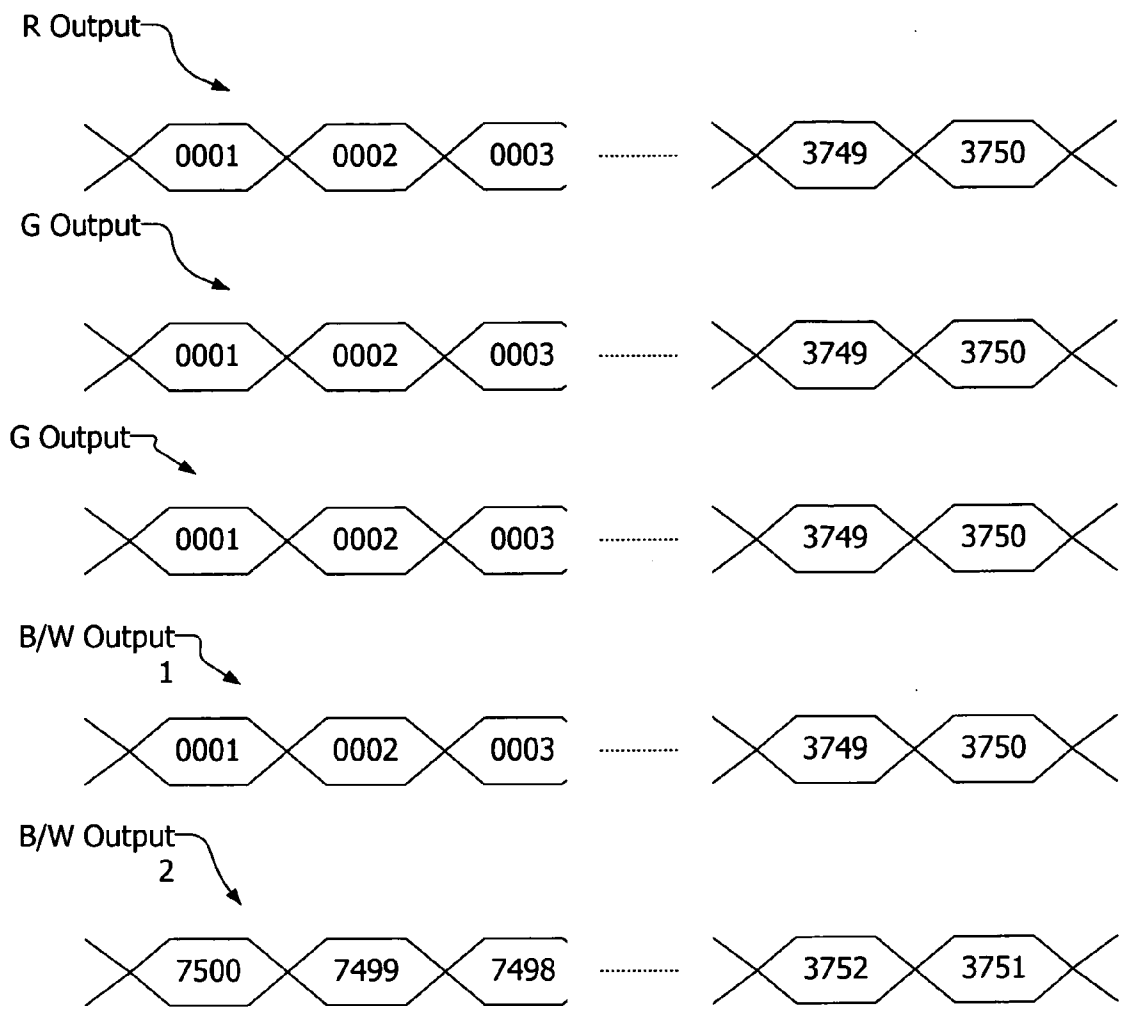

FIG. 15

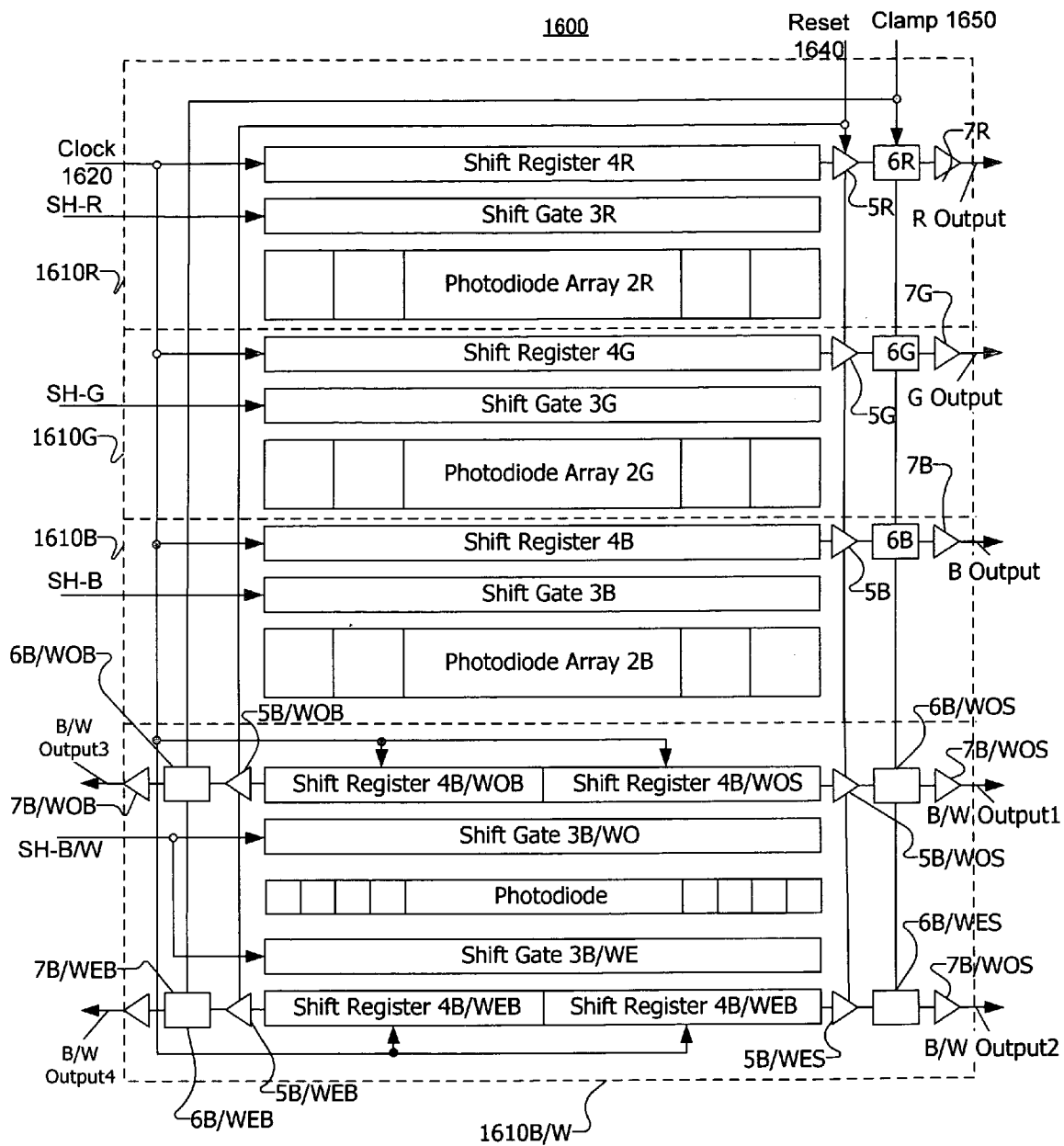

FIG. 16

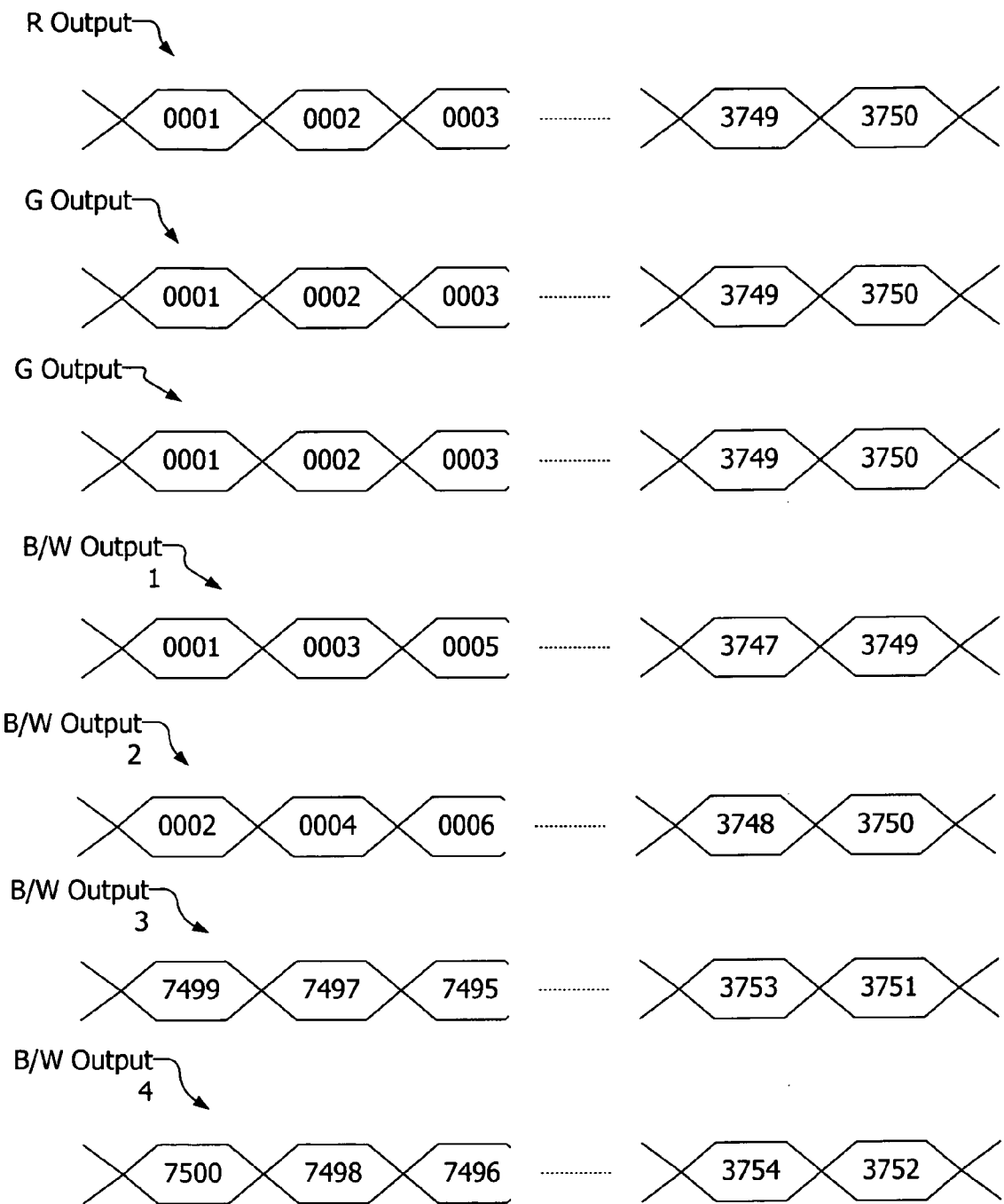

FIG. 17

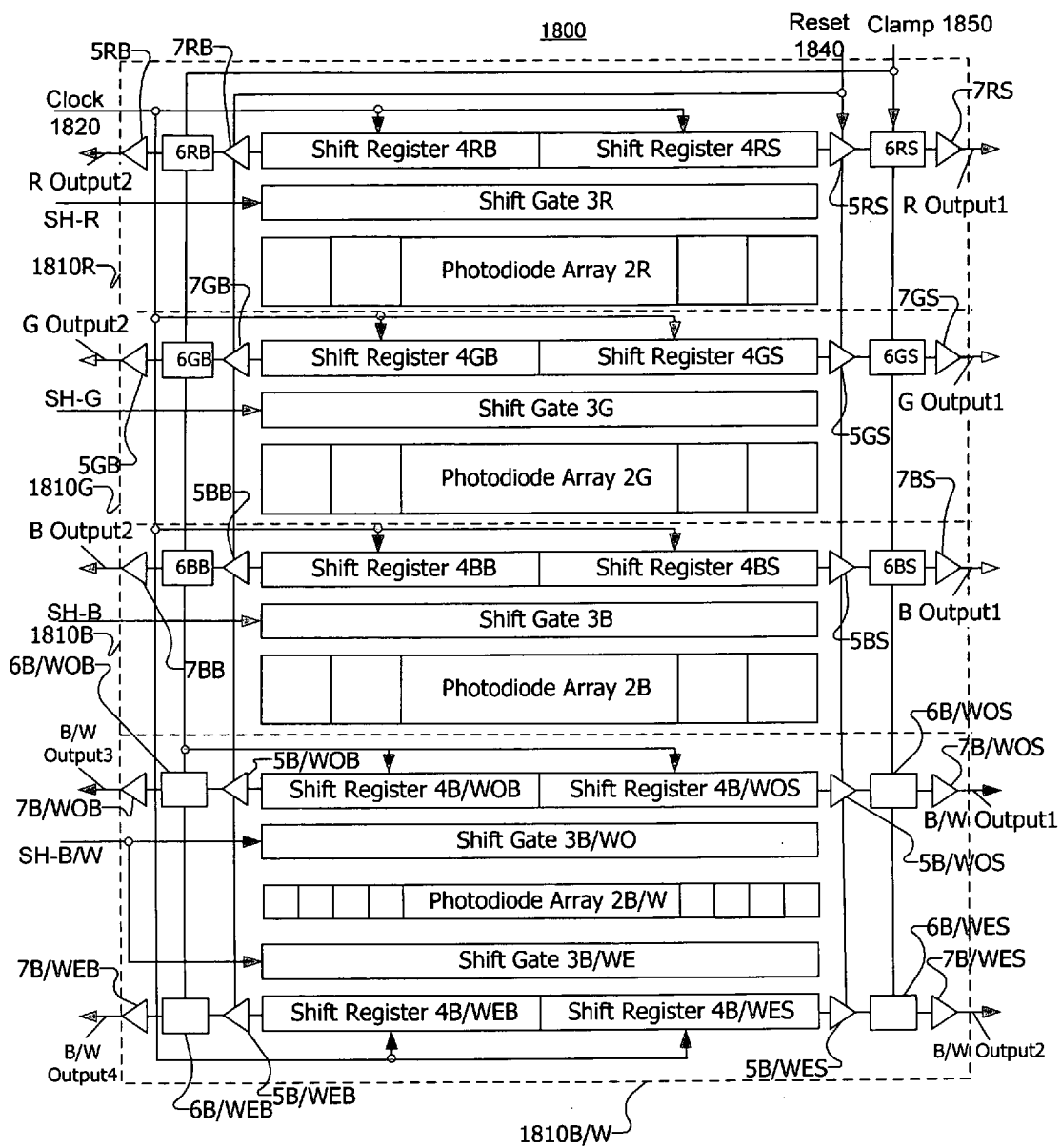

FIG. 18

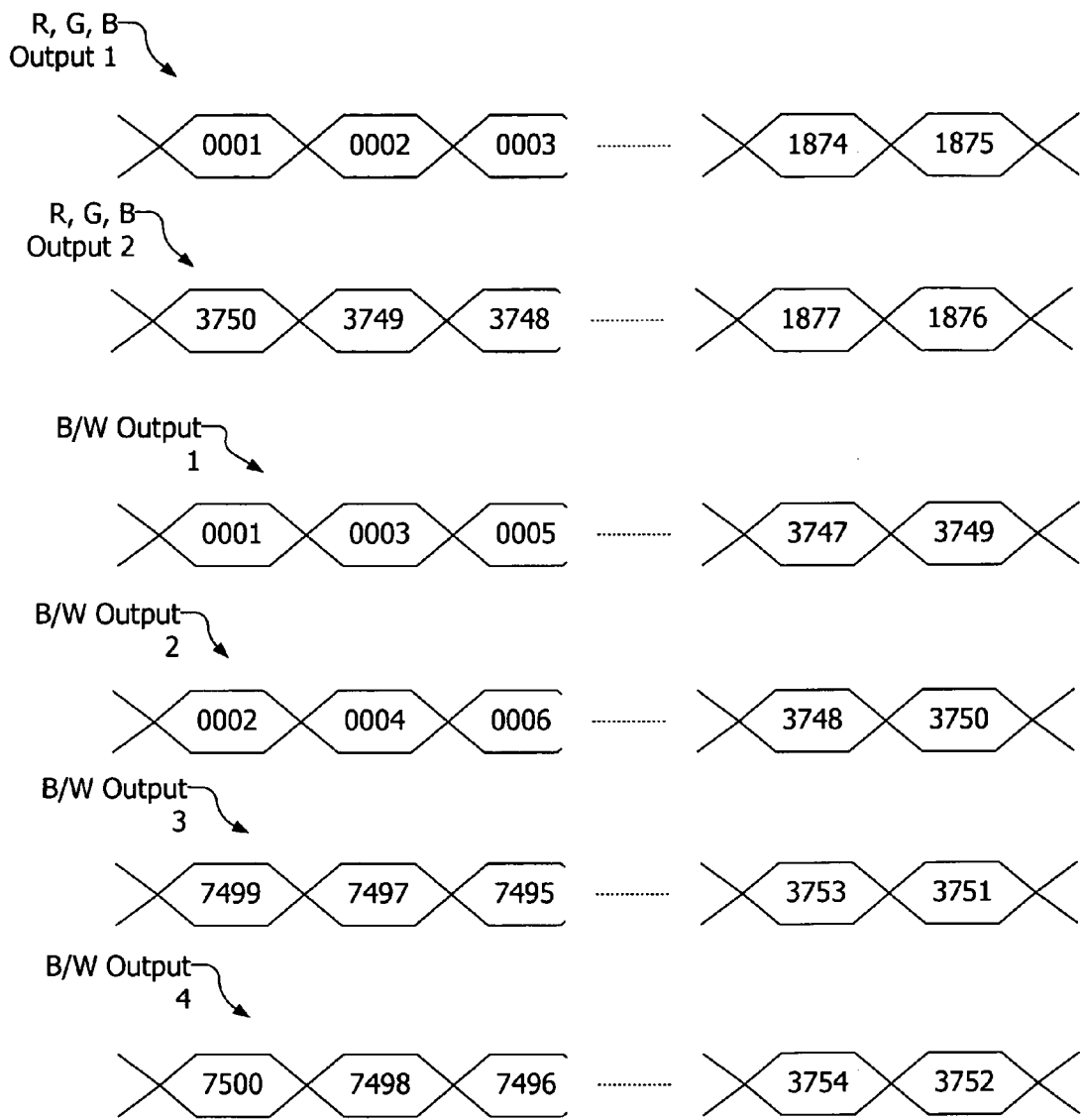

FIG. 19

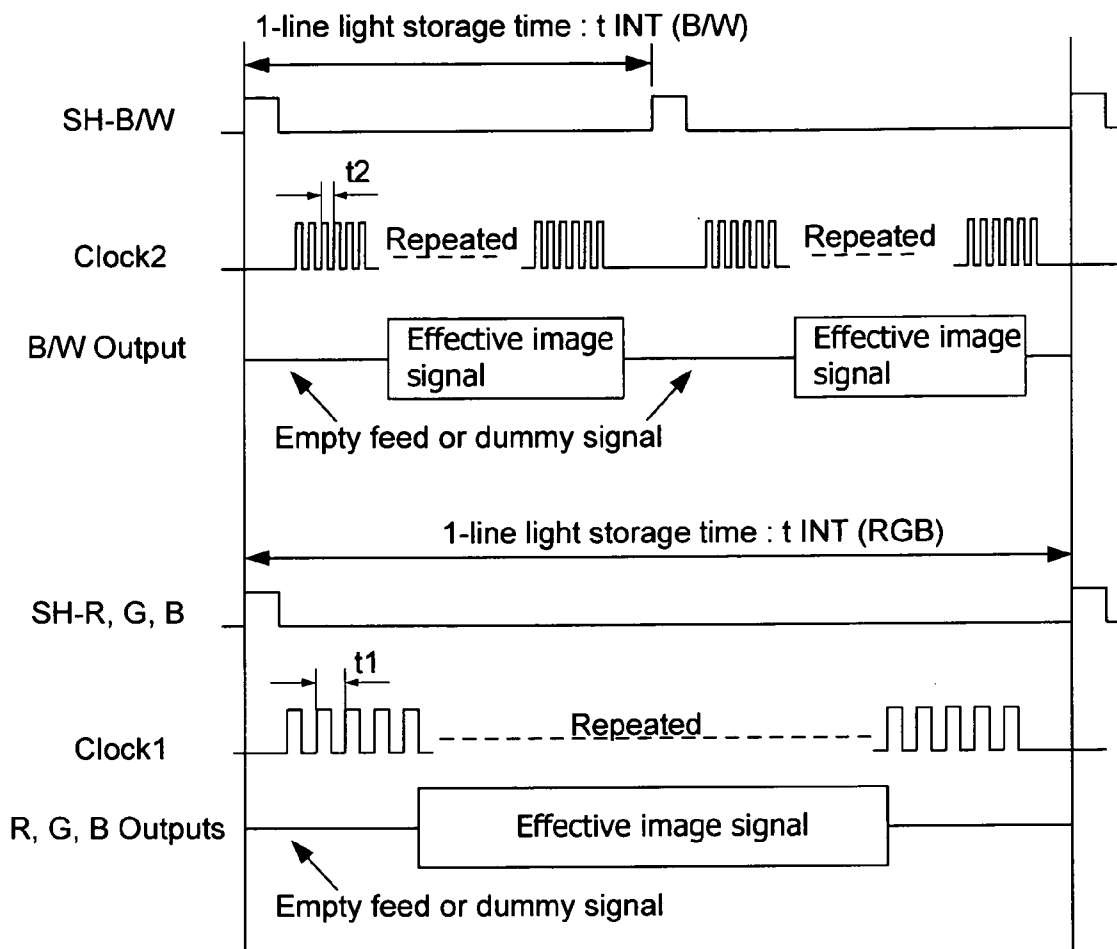

FIG. 21

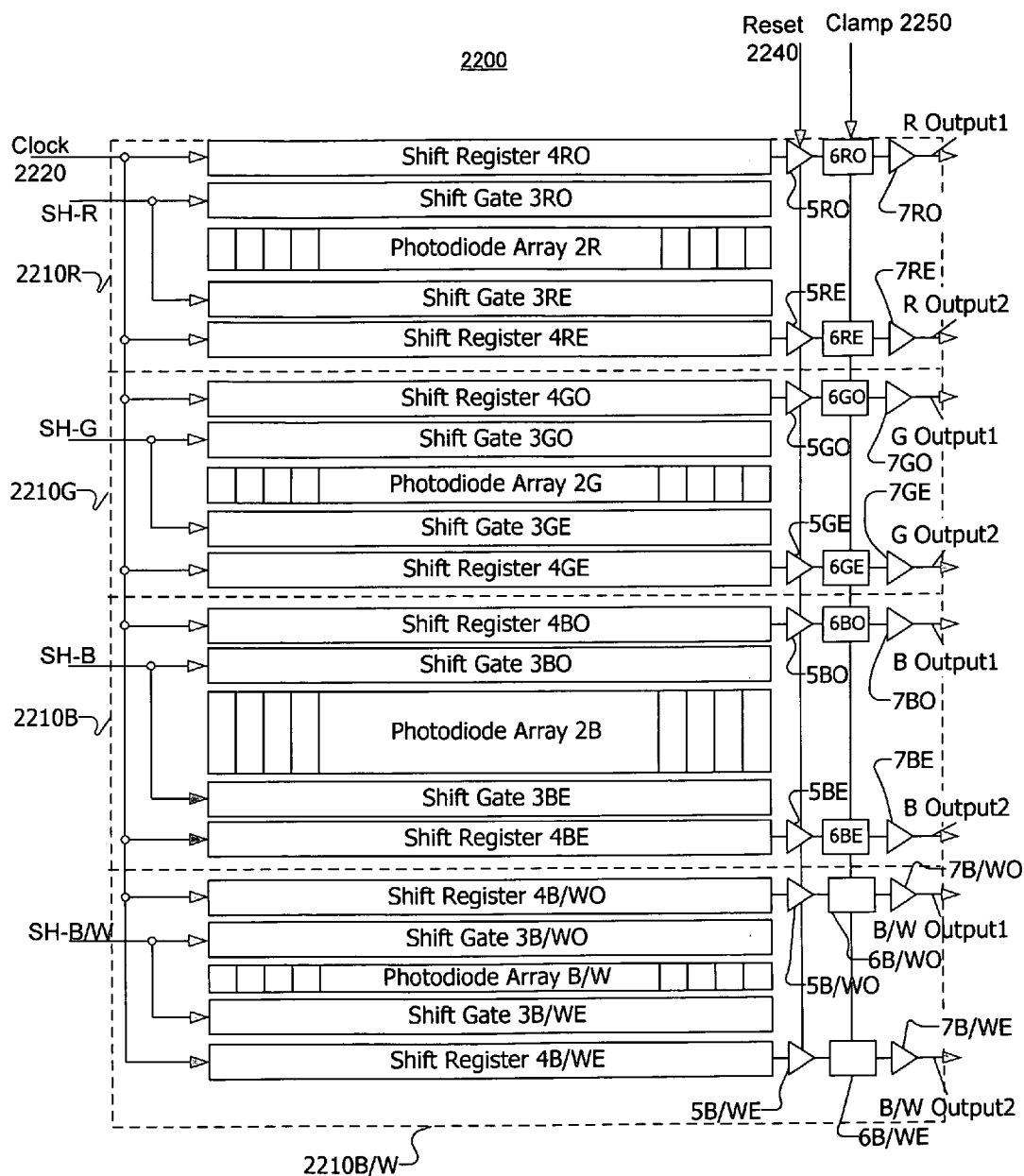

FIG. 22

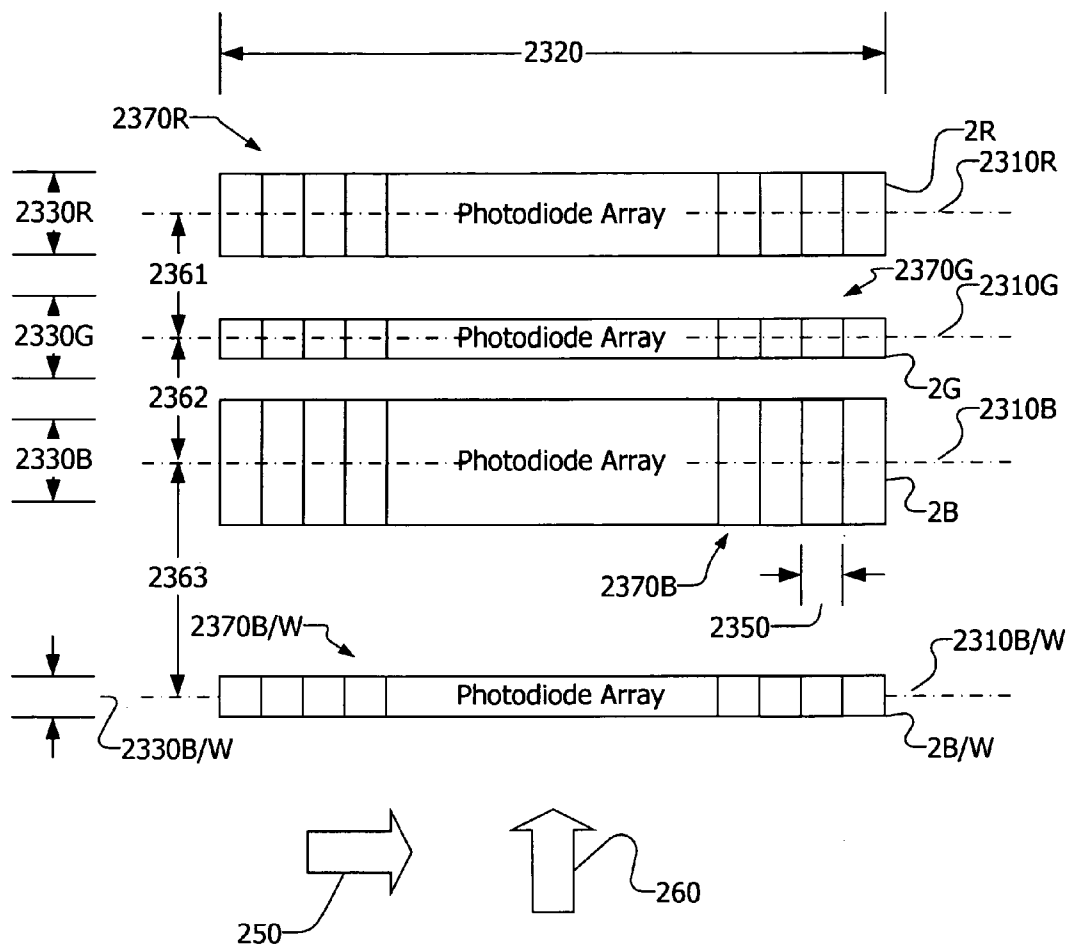

FIG. 23

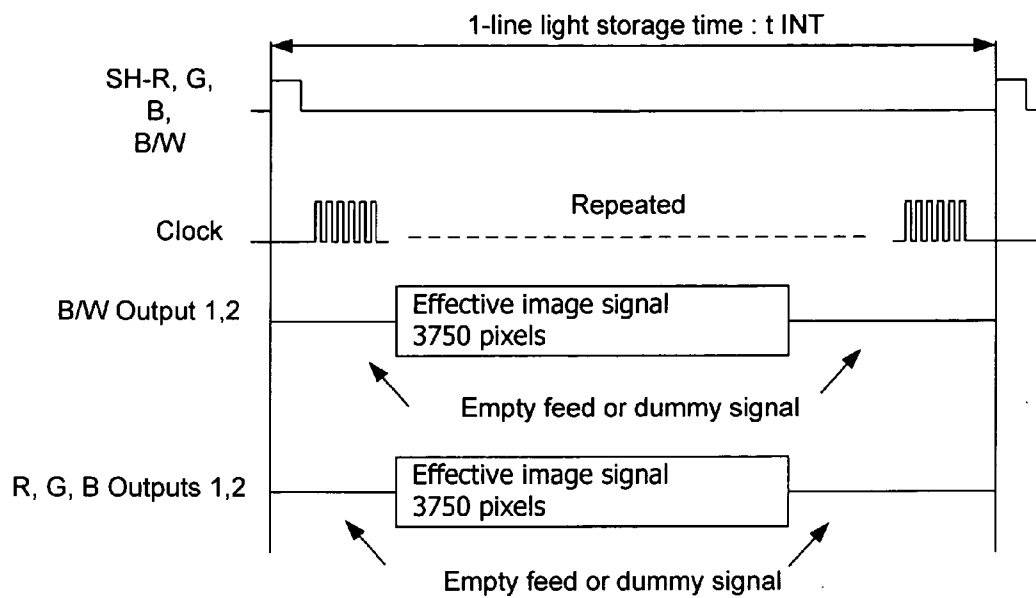

FIG. 24

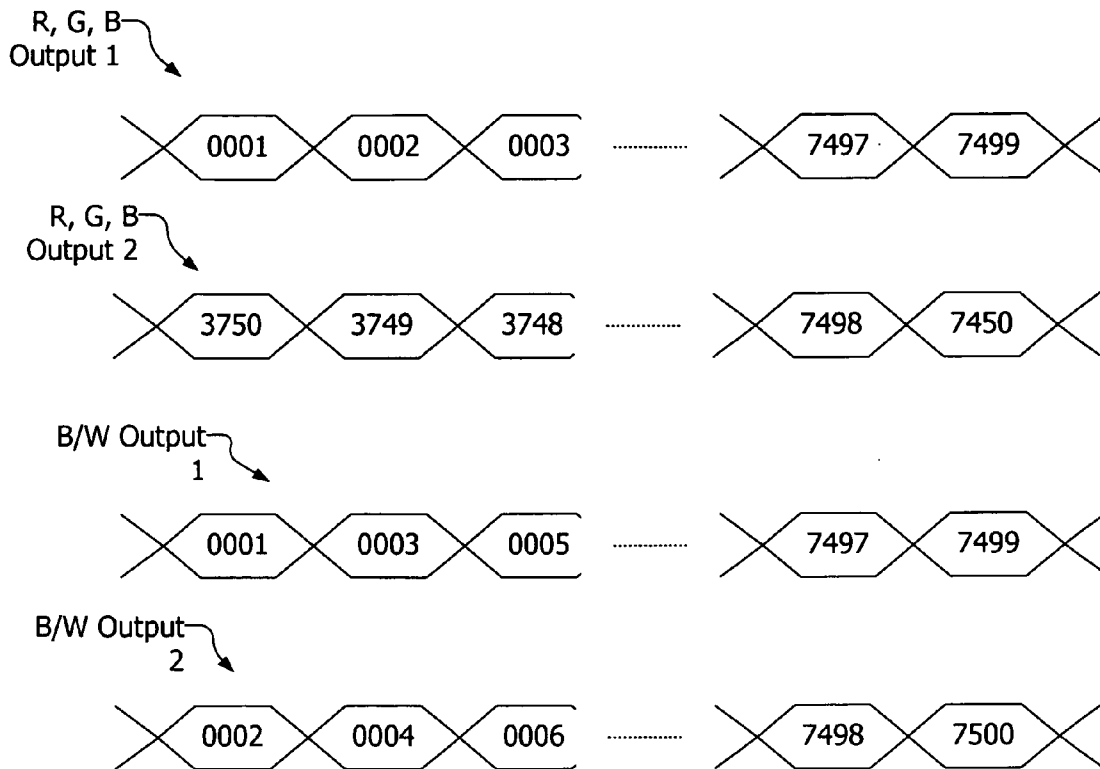

FIG. 25

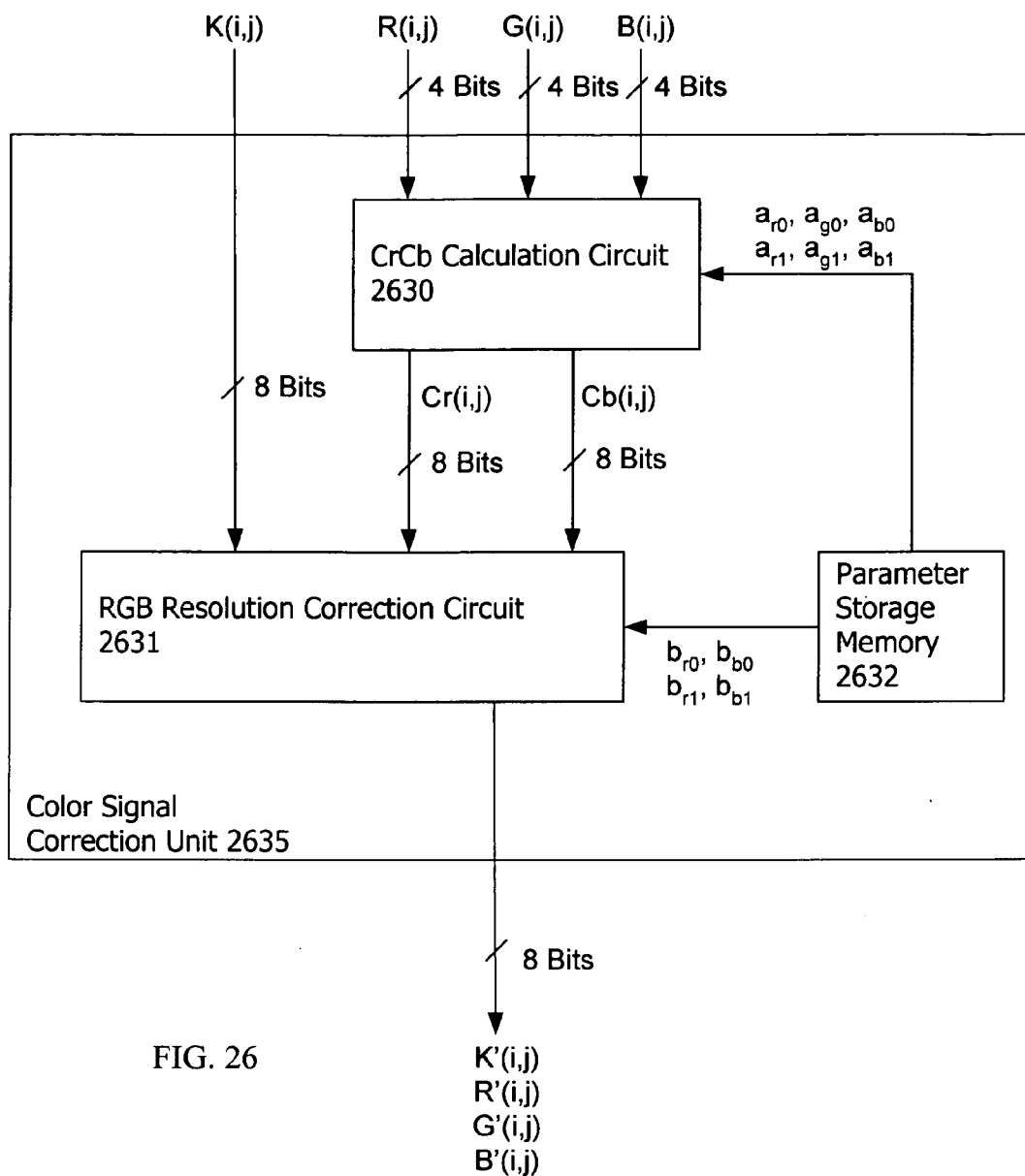

FIG. 26

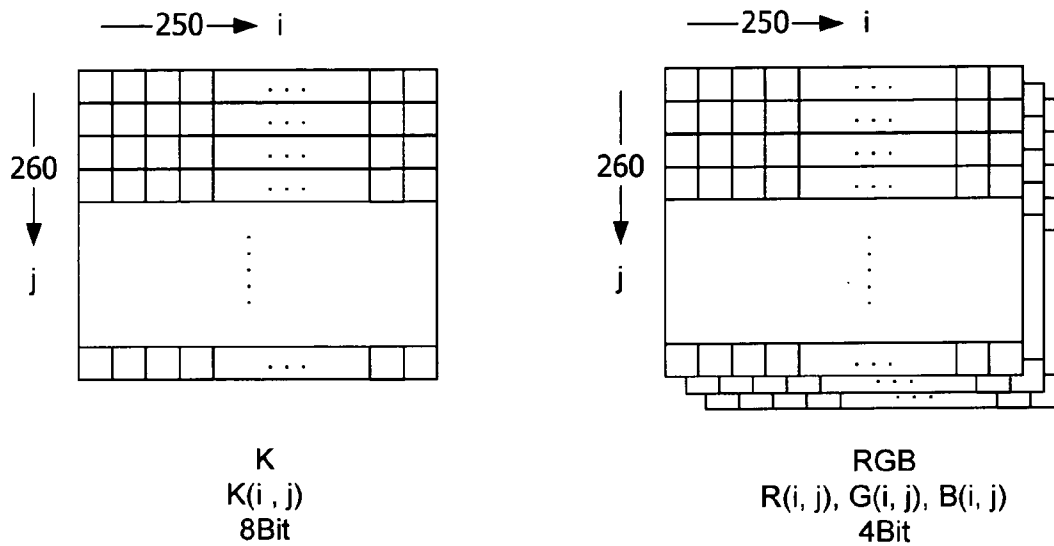

FIG. 27

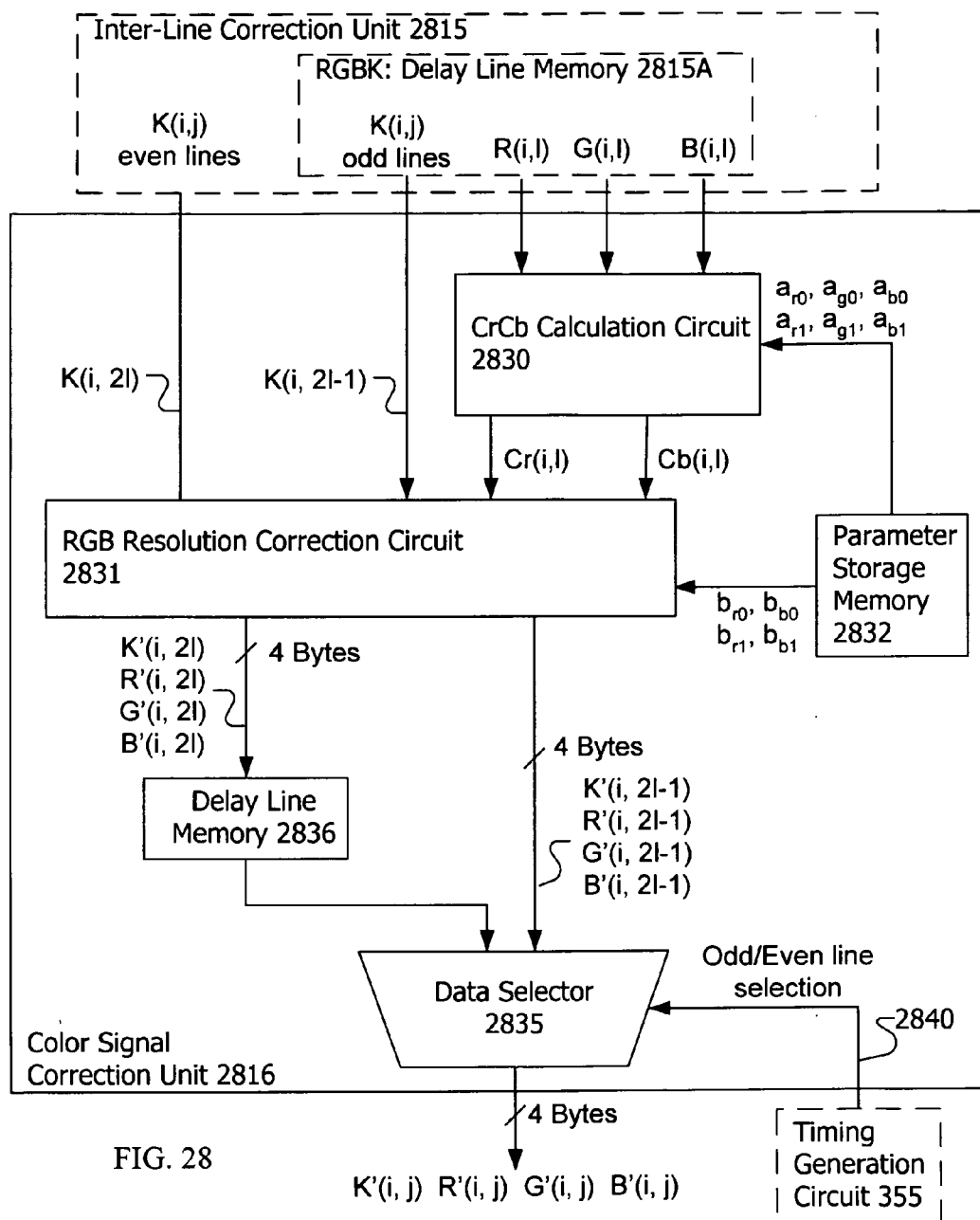

FIG. 28

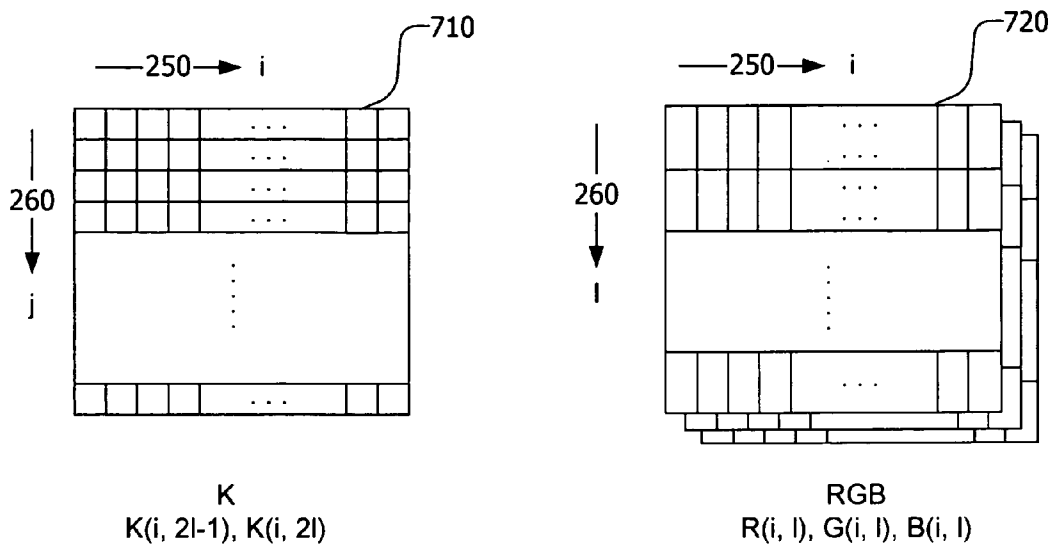

FIG. 29

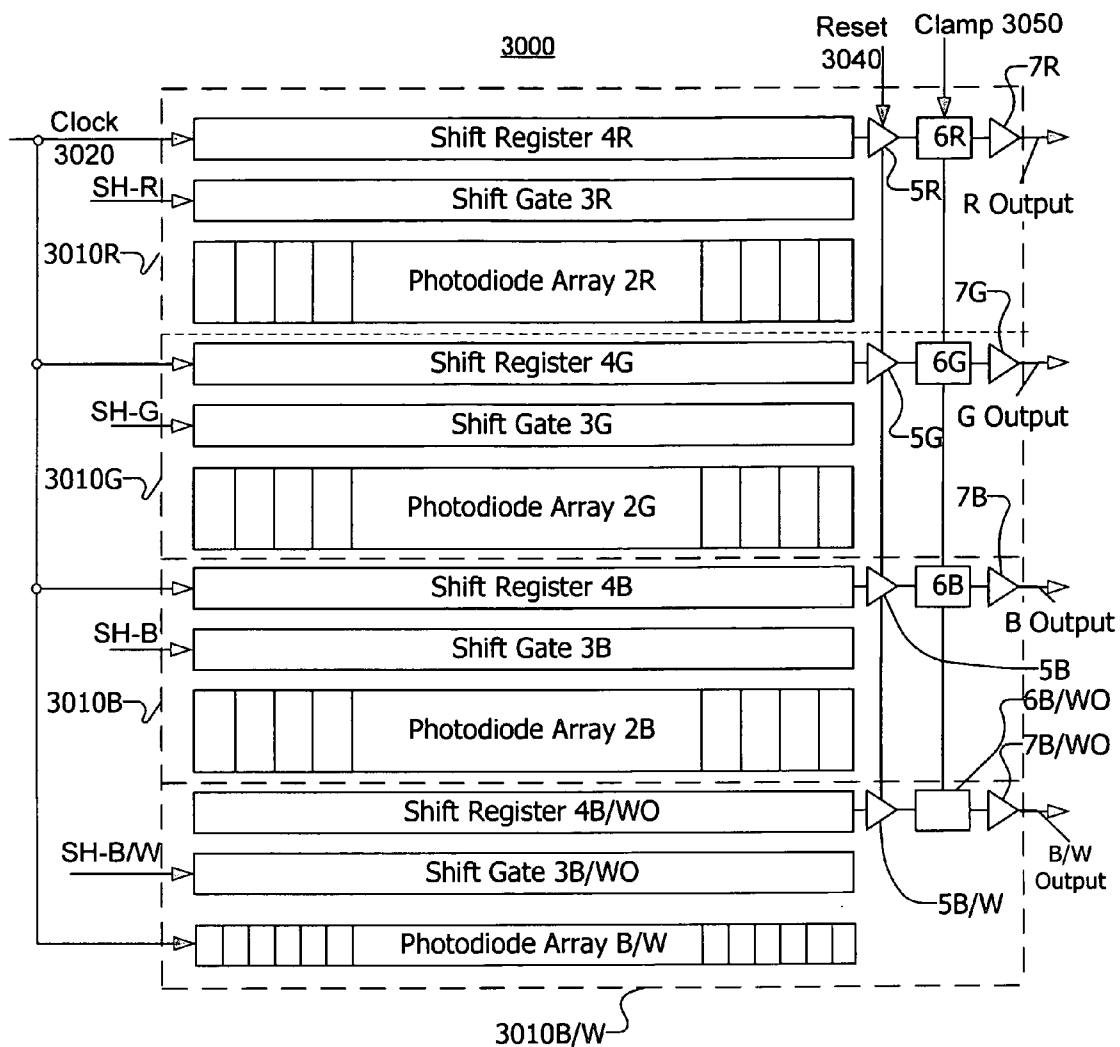

FIG. 30

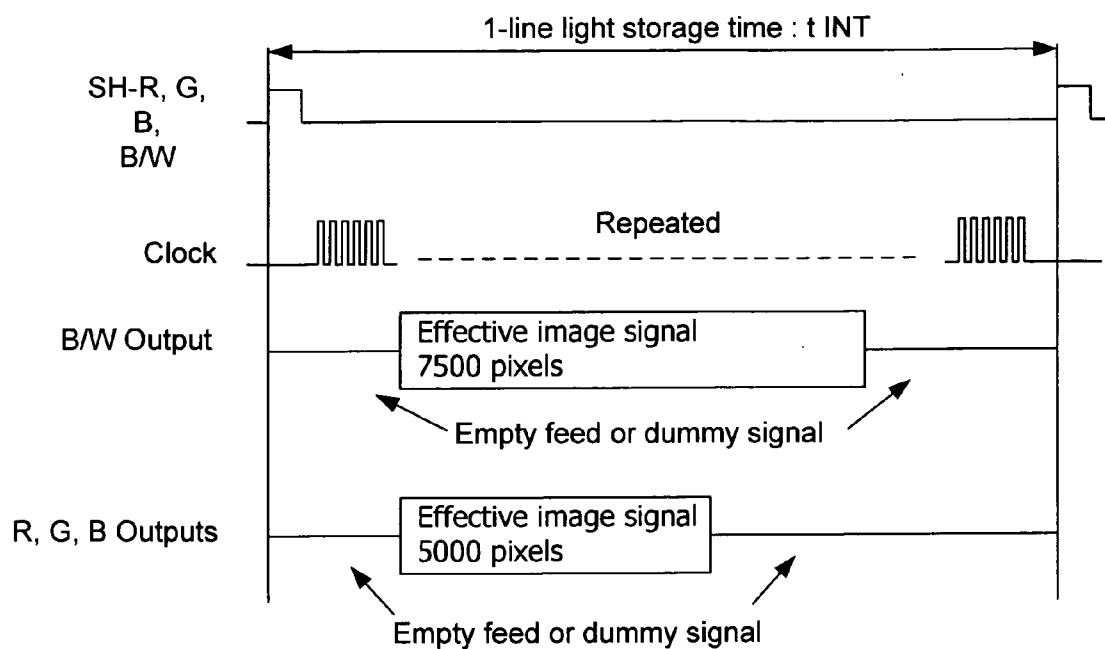
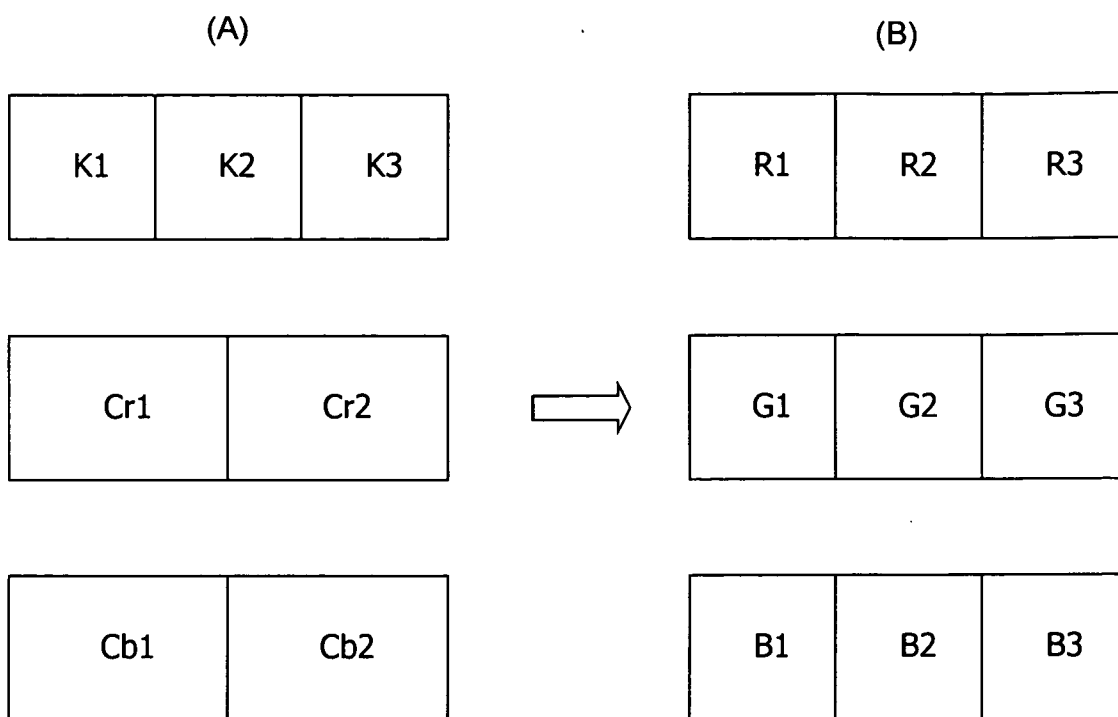

FIG. 31

FIG. 32



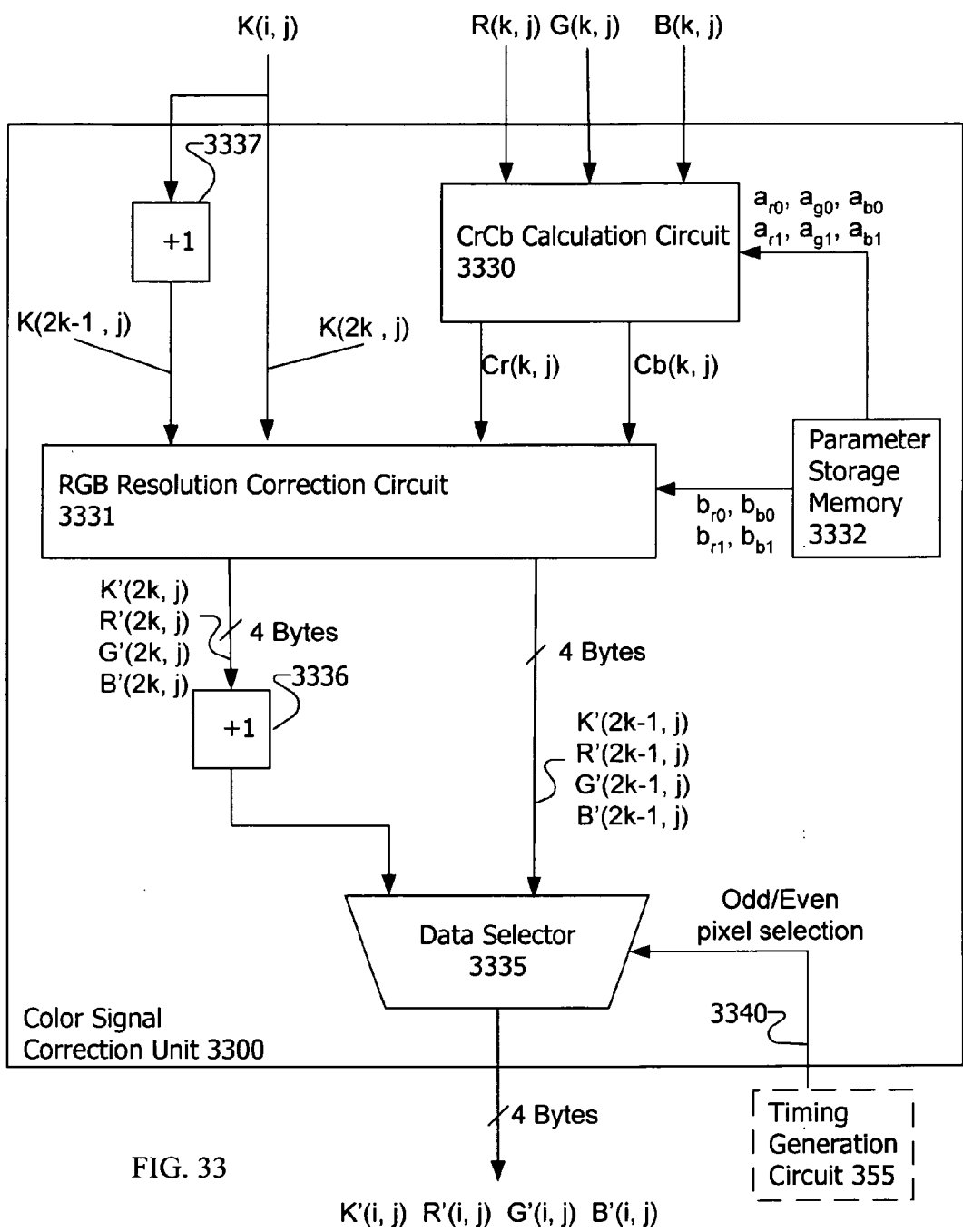

FIG. 33

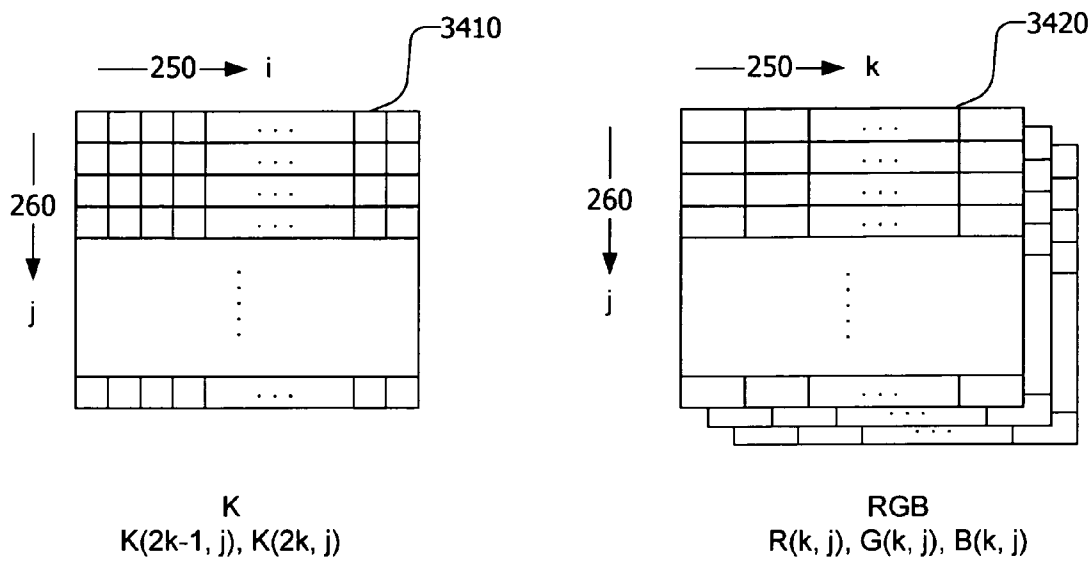

FIG. 34

COLOR SIGNAL COMPENSATION**RELATED APPLICATION INFORMATION**

[0001] This application is a continuation-in-part of U.S. Application No. 60/452,338 filed Mar. 5, 2003, which is incorporated herein by reference.

[0002] This application is related to U.S. application Ser. No. 09/955,090, which is incorporated herein by reference for its disclosure of a scanner, its construction and operation.

[0003] This application is related to U.S. application Ser. No. 10/769,616 filed Jan. 30, 2004 which is incorporated herein by reference.

NOTICE OF COPYRIGHT AND TRADE DRESS

[0004] A portion of the disclosure of this patent document contains material which is subject to copyright protection. This patent document may show and/or describe matter which is or may become trade dress of the owner. The copyright and trade dress owner has no objection to the facsimile reproduction by any one of the patent disclosure as it appears in the Patent and Trademark Office patent files or records, but otherwise reserves all copyright and trade dress rights whatsoever.

BACKGROUND OF THE INVENTION

[0005] 1. Field of the Invention

[0006] The present invention relates to color signal compensation.

[0007] 2. Description of Related Art

[0008] Typical image sensors, such as those used in color copiers are one-dimensional and have either a 3-line CCD unit or a 4-line CCD unit. A typical 3-line CCD unit has three photodiode arrays—one for each of the three primary colors R, G and B. A typical 4-line CCD unit has, in addition to the RGB photodiode arrays, a monochrome (B/W) photodiode arrays.

[0009] Many image reading devices, such as color copiers, include a color mode and a monochrome mode. In the color mode, a color image is read. In the monochrome mode, a monochrome image is read. The typical 3-line CCD unit extracts a monochrome signal from the signals from the RGB photodiode arrays. The typical 4-line CCD unit obtains a monochrome signal from the B/W photodiode arrays.

DESCRIPTION OF THE DRAWINGS

[0010] FIG. 1 is a frontal outline view of an image forming apparatus in accordance with the invention.

[0011] FIG. 2 is a partial cut-away side-view of the image forming apparatus of FIG. 1.

[0012] FIG. 3 is a block diagram of an image reading apparatus in accordance with the invention.

[0013] FIG. 4 is a block diagram of an image sensor unit of the first embodiment.

[0014] FIG. 5 is an illustration for an arrangement of photodiode arrays of the first embodiment.

[0015] FIG. 6 is a timing chart showing the outline of output from the image sensor unit of the first embodiment.

[0016] FIG. 7 shows an outline of a color scanning process of the first embodiment.

[0017] FIG. 8 is a block diagram of a color signal correction unit of the first embodiment.

[0018] FIG. 9 is a first timing chart showing the operation of the image sensor unit of the first embodiment.

[0019] FIG. 10 is a second timing chart showing the operation of the image sensor unit of the first embodiment.

[0020] FIG. 11 is a block diagram of an image sensor unit of the second embodiment.

[0021] FIG. 12 is an illustration for an arrangement of photodiode arrays of the second embodiment.

[0022] FIG. 13 is a timing chart showing the operation of the image sensor unit of the second embodiment.

[0023] FIG. 14 is a block diagram of the image sensor unit of the third embodiment.

[0024] FIG. 15 is a timing chart showing the outline of output from the image sensor unit of the third embodiment.

[0025] FIG. 16 is a block diagram of the image sensor unit of the fourth embodiment.

[0026] FIG. 17 is a timing chart showing the outline of output from the image sensor unit of the fourth embodiment.

[0027] FIG. 18 is a block diagram of the image sensor unit of the fifth embodiment.

[0028] FIG. 19 is a timing chart showing the outline of output from the image sensor unit of the fifth embodiment.

[0029] FIG. 20 is a block diagram of the image sensor unit of the sixth embodiment.

[0030] FIG. 21 is a timing chart showing the operation of the image sensor unit of the sixth embodiment.

[0031] FIG. 22 is a block diagram of the image sensor unit of the seventh embodiment.

[0032] FIG. 23 is an illustration for an arrangement of photodiode arrays of the seventh embodiment.

[0033] FIG. 24 is a timing chart showing the operation of the image sensor unit of the seventh embodiment.

[0034] FIG. 25 is a timing chart showing the outline of output from the image sensor unit of the seventh embodiment.

[0035] FIG. 26 is a block diagram of a color signal correction unit of the seventh embodiment.

[0036] FIG. 27 is an illustration showing the outline of the process of the color signal correction unit shown in FIG. 26.

[0037] FIG. 28 is a block diagram of a color signal correction unit of the eighth embodiment.

[0038] FIG. 29 is an illustration showing the outline of the process of the color signal correction unit of the eighth embodiment.

[0039] FIG. 30 is a timing chart showing the operation of the image sensor unit of the ninth embodiment.

[0040] FIG. 31 is a timing chart showing the operation of the image sensor unit of the ninth embodiment.

[0041] FIG. 32 is an auxiliary illustration for the process of the color signal correction unit of the ninth embodiment.

[0042] FIG. 33 is a block diagram of a color signal correction unit of the second embodiment.

[0043] FIG. 34 shows an outline of a color scanning process of the second embodiment.

DETAILED DESCRIPTION OF THE INVENTION

[0044] Throughout this description, the embodiments and examples shown should be considered as exemplars, rather than limitations on the apparatus and methods of the present invention.

[0045] Referring now to FIG. 1, there is shown a frontal outline view of an image forming apparatus 100 in accordance with the invention. The image forming apparatus 100 may be, for example, a copier, fax, printer or multi-function peripheral (MFP). The image forming apparatus 100 may form the image on such media as paper or overhead transparencies.

[0046] The image forming apparatus 100 is one type of an image reading apparatus. As used herein, an "image reading apparatus" is a unitary electronic device which forms images. An image reading apparatus may also be a still camera, video camera, telescope, scanner, bar code reader, robot having machine vision, or other device which incorporates an image sensor.

[0047] The image forming apparatus 100 has an input feeder 130, an operation element 140 and an output tray 150. The input feeder 130, the operation element 140 and the output tray 150 may be configured as those known in the art.

[0048] Referring now to FIG. 2 there is shown a partial cut-away side-view of the image forming apparatus 100 of FIG. 1 having an original sheet (e.g., of paper) 230 disposed on an original glass 220. The image forming apparatus 100 further includes a reading mechanical system 210 and a white lamp 280. The white lamp 280 is disposed opposite the original glass 220 from the original sheet 220.

[0049] The original sheet 230 may have an image disposed thereon, such as text or graphics. The original sheet 230 is moved onto the original glass 220. The white lamp 280 illuminates the original sheet 230. The reading mechanical system 210 generates signals corresponding to the image on the original sheet 230.

[0050] To generate signals for the entire image on the original sheet 230, there may be a scanning process. For example, the reading mechanical system 210 may scan the original sheet 230 one line at a time. The reading mechanical system 210 may include a one-dimensional image sensor unit. By using a two-dimensional image sensor unit in the reading mechanical system 210, it may be possible to scan images on the original sheet 230 with no or little movement. Furthermore, multi-dimensional image sensor units may be provided, for example for scanning three dimensional and complex objects.

[0051] There may be a main scanning direction 250 and a sub-scanning direction 260. The main scanning direction 250 may follow the axial direction of a photosensitive drums (not shown) in the image forming apparatus 100. The

sub-scanning direction 260 may follow the rotation direction of the photosensitive drums, and may be perpendicular to the main scanning direction 250. The original sheet 230, reading mechanical system 210 and/or intermediate optics may have mechanical motion to allow complete scanning. Thus, there may be mechanical motion in the main scanning direction 250 and in the sub-scanning direction 260. This motion may be by the entire reading mechanical system 210 or by one or more parts. This motion may be at one or more fixed or variable speeds.

[0052] Where the image reading apparatus is other than an image forming apparatus, the image reading apparatus may be used for reading an image of a solid or flat object. The solid or flat object may be located proximate the image reading apparatus or a distance from the image reading apparatus. The image reading apparatus may include a light source, such as the white lamp 280 of the image forming apparatus 100. Alternatively, the object may be illuminated from an external light source or ambient light.

[0053] (A) First Embodiment

[0054] A-1 Constitution Of The First Embodiment

[0055] Referring now to FIG. 3 there is shown a block diagram of an image reading apparatus 300 in accordance with one aspect of the invention. The image reading apparatus 300 includes portions designed for image processing and portions designed for control. The image processing portions include an image sensor unit 310, an analog processing unit 315, an analog-to-digital conversion circuit (ADC) 320, a shading correction unit 325, an inter-line correction circuit 330, a color signal correction unit 335, a page memory 340, and an output image processing unit 350. The control portions include a timing generation circuit 355, a control unit 360, a memory 370, a control panel 365, a mechanical system driving unit 375 and a white lamp driving unit 380.

[0056] The image reading apparatus 300 includes hardware and may include software, altogether for providing the functionality and features described below. The image reading apparatus 300 may therefore include one or more of: logic arrays, memories, analog circuits, digital circuits, software, firmware, and processors such as microprocessors, field programmable gate arrays (FPGAs), application specific integrated circuits (ASICs), programmable logic devices (PLDs) and programmable logic arrays (PLAs). The hardware and firmware components of the image reading apparatus 300 may include various specialized units, circuits, software and interfaces for providing the functionality and features described below.

[0057] The image sensor unit 310 may generate color signals and monochrome signals and output them on color channels 311 and monochrome channels 312. The image sensor unit 310 may be included in the reading mechanical system 210 (FIG. 2). The image sensor unit 310 may be or include a 4-line CCD or other arrays of photodiodes. The color signals may be formed in one channel for each color, for example each of the three primary colors R, G and B. The monochrome signals may be formed in two monochrome channels. The color signals and the monochrome signals may be output simultaneously, for example, in parallel, or they may be switched. The image sensor unit 310 may be embodied as one or more integrated circuit chips. The image

sensor unit **310** may include or be used in conjunction with color filters arranged with respect to the CCDs for each color.

[0058] As used herein, a “charge-coupled device” or “CCD” is a light-sensitive integrated circuit that produces and stores (generally temporarily) electric charges representing light levels to which the CCD is exposed. A CCD may be formed of an array of photodiodes to thereby provide a representation of an image to which the CCD is exposed. The array may be one- or multi-dimensional. A “photodiode” is a semiconductor diode that generates an electric signal when exposed to light. The photodiodes of a CCD may have particular sensitivities, such as for particular light frequencies or levels.

[0059] The analog processing unit **315** receives the color signals on the color channels **311** and the monochrome signals on the monochrome channels **312**. The analog processing unit **315** processes the color and monochrome signals from the image sensor unit **310** so that they are suitable for conversion to digital signals. The analog processing unit **315** may perform such processing as level shifting, removal of nozzle component, and amplification. To perform this processing, the analog processing unit **315** may include one or more of: a coupling capacitor, a correlated double-sampling (CDS) circuit, a sample and hold circuit, a gain amplifier and an offset removal circuit. The analog processing unit **315** outputs the processed color signals on the color channels **316** and the monochrome signals on the monochrome channels **317**.

[0060] The ADC **320** receives the processed color signals on the color channels **316** and the monochrome signals on the monochrome channels **317**. The ADC **320** converts the processed color and monochrome signals into digital signals for output on channels **321**. The ADC **320** also merges the two analog monochrome signals into a single digital monochrome signal for output on a channel **322**.

[0061] The shading correction unit **325** receives the digital signals from ADC **320** on the channels **321**, **322**. The shading correction unit **325** corrects the digital signals for variations of sensitivity of the photodiodes in the image sensor unit **310** and illumination. There may be variations in the illumination of the object, and it may be desirable to correct for these variations, especially in the main scanning direction **250**. The shading correction unit **325** outputs signals on channels **326**, wherein there may be one channel each for the three primary colors and monochrome.

[0062] The arrays of photodiodes in the image sensor unit **310** may have differences in position which can give rise to misalignment of the read image. The inter-line correction circuit **330** corrects the color and monochrome signals for these differences in position. The inter-line correction circuit **330** receives signals on the channels **326** and outputs signals on the channels **331**.

[0063] The inter-line correction circuit **330** may have a second function. While one color output is carried out (in correspondence to one line), the monochrome outputs may be carried out twice (in correspondence to two lines). The inter-line correction circuit **330** may perform an interpolation process—doubling the number of lines (i.e., the resolution) in the sub-scanning direction **260** for the color output. This interpolation process, for example, can set the

average of signals on respective upper and lower scanned lines to a signal on a line in an intermediate position (virtual position) thereof.

[0064] The color signal correction unit **335** may be used when the image reading apparatus is used in the color imaging mode. The color signal correction unit **335** enhances the resolution of the read color image by using information in the monochrome signals. For example, the color signal correction unit **335** may convert a signal of 300 dpi to a signal of 600 dpi. The color signal correction unit **335** receives color signals and the monochrome signals from the inter-line correction circuit **330** on the channels **331**. The color signal correction unit **335** outputs color and monochrome signals on channels **336**.

[0065] The page memory **340** may store the read image signals, which the page memory **340** may receive from the color signal correction unit **335** via channel **341**. In color imaging mode, the page memory **340** may store corrected read image signals. In monochrome mode, the page memory **340** may store uncorrected read image signals.

[0066] The output image processing unit **350** provides the final image output of the image reading apparatus **300**. The output image processing unit **350** is an interface to an output destination, and may convert signals according to the needs of the output destination. For example, the output image processing unit **350** may change the range of a gamma control according to devices such as display or printer. The output image processing unit **350** receives color and monochrome signals on channels **336** and outputs processed signals on channels **351**. Although the color and monochrome signals received by the output image processing unit **350** come from the color signal correction unit **335**, these signals may be obtained directly from the color signal correction unit **335** or indirectly from the page memory **340**.

[0067] The timing generation circuit **355**, under the control of the control unit **360**, generates and gives timing signals for the image sensor unit **310**, the analog processing unit **315**, the ADC **320**, the shading correction unit **325**, the inter-line correction circuit **330**, the color signal correction unit **335** and the page memory **340**.

[0068] The control unit **360** may control the image reading apparatus **300** according to programs and data stored in the memory **370**. The control unit may use the memory **370** as a working memory.

[0069] The memory **370** provides long term and short term storage of data and programs for the image reading apparatus **300**. The memory **370** may be combined with the page memory **340**. In some embodiments, the memory **370** is not expandable or may be difficult to expand, whereas the page memory **340** may be designed for expandability.

[0070] The control panel **365** receives input information by a user. This input information may include the operation mode (e.g., color or monochrome mode) and a selected number of printing sheets of paper.

[0071] The mechanical system driving unit **375** operates under control of the control unit **360**. The mechanical system driving unit **375** drives a moving mechanism in the sub-scanning direction **260**. The moving speed of the moving mechanism in the sub-scanning direction **260** may be the same in color mode and monochrome mode. In such a case,

the mechanical system driving unit **375** performs the driving operation without distinction of the color mode and monochrome mode.

[0072] The white lamp driving unit **380** drives a white lamp, which may irradiate white light to an object such as a document. The white lamp driving unit **380** operates under the control of the control unit **360**.

[0073] Referring now to **FIG. 4**, there is shown a block diagram of an image sensor unit **400** of a first embodiment of the invention. The image sensor unit **400** may be used as the image sensor unit **310**. The image sensor unit **400** is of the 4-line type, and includes three photoelectric converters **410R**, **410G**, **410B** for color and one photoelectric converter **410B/W** for monochrome. The letters R, G, B and B/W refer to the respective color: red, green, blue or monochrome (black/white).

[0074] The photoelectric converters **410R**, **410G**, **410B**, **410B/W** each have a single linear (one-dimensional) photodiode array **2R**, **2G**, **2B**, **2B/W**, comprising a number of photodiodes. Each photodiode of the photodiode arrays **2R**, **2G**, **2B**, **2B/W** has a sequential reference number from some arbitrary starting point in the respective array. Accordingly, based upon its reference number, a photodiode may be referred to as "odd" or "even." Those elements whose reference number ends in "O" process the stored charges of the odd-numbered photodiodes and those elements whose numeral ends in "E" process the stored charges of the even-numbered photodiodes.

[0075] The photodiodes of the photodiode arrays **2R**, **2G**, **2B**, **2B/W** may be arranged in the main scanning direction **250**. The photodiodes store (photoelectrically convert) charges according to a received quantity of light. The photodiodes may be adapted to be sensitive to predetermined frequencies.

[0076] The color photoelectric converters **410R**, **410G**, **410B** respectively have: shift gates **3R**, **3G**, **3B**; shift registers **4R**, **4G**, **4B**; reset gates **5R**, **5G**, **5B**; clamp circuits **6R**, **6G**, **6B**; and amplifiers **7R**, **7G**, **7B**.

[0077] The monochrome photoelectric converter **410B/W** has two channels, referred to herein as "odd" and "even." The monochrome photoelectric converter **410B/W** includes two shift gates **3B/WO**, **3B/WE**; two shift registers **4B/WO**, **4B/WE**; two reset gates **5B/WO**, **5B/WE**; two clamp circuits **6B/WO**, **6B/WE**; and two amplifiers **7B/WO**, **7B/WE**.

[0078] The stored charges of the photodiode arrays **2R**, **2G**, **2B** are shifted to the corresponding shift registers **4R**, **4G**, **4B** via the shift gates **3R**, **3G**, **3B** which are put into an open state according to shift signals SH-R, SH-G, SH-B. The stored charges of the photodiode arrays **2B/WO**, **2B/WE** are shifted to the corresponding shift registers **4B/WO**, **4B/WE** via the shift gates **3B/WO**, **3B/WE** which are put into an open state according to shift signal SH-B/W. The shift signals SH-R, SH-G, and SH-B may be the same. The shift signal SH-B/W may have a cycle which is $\frac{1}{2}$ of the cycle of the shift signals SH-R, SH-G, SH-B. The shift registers **4R**, **4G**, **4B**, **4B/W** may be CCD analog shift registers.

[0079] To the respective shift registers **4R**, **4G**, **4B**, **4B/WO**, **4B/WE** the stored charges of the photodiode arrays **2R**, **2G**, **2B**, **2B/WO**, **2B/WE** are shifted at predetermined

timing. The respective shift registers **4R**, **4G**, **4B**, **4B/WO**, **4B/WE** may output the shifted stored charges as respective serial signals (a one-dimensional image signal) according to a single clock signal **420**. In this case, in order to prevent the output signals from interfering, a reset signal **440** may be provided via the reset gates **5R**, **5G**, **5B**, **5B/WO**, **5B/WE**. Thereafter, the output signals are clamped by the clamp circuits **6R**, **6G**, **6B**, **6B/WO**, **6B/WE** and moreover amplified and outputted by the corresponding amplifiers **7R**, **7G**, **7B**, **7B/WO**, **7B/WE**.

[0080] Referring now to **FIG. 5**, there is shown a diagram of the photodiode arrays **2R**, **2G**, **2B**, **2B/W** of the first embodiment. The photodiode arrays **2R**, **2G**, **2B**, **2B/W** may be rectilinear and have a uniform length **520**. The photodiode arrays **2R**, **2G**, **2B**, **2B/W** may have respective widths **530R**, **530G**, **530B**, **530B/W**. The order of the four kinds of photodiode arrays **2R**, **2G**, **2B**, **2B/W** in the sub-scanning direction **260** is optional. However, to obtain better balance of the three color outputs (R Output, G Output, B Output), the monochrome photodiode array **2B/W** may be positioned at an end (on the uppermost part or lowermost part shown in **FIG. 4**) of the photodiode arrays **2R**, **2G**, **2B** instead of between them. **FIG. 4** shows a case that the monochrome photodiode array **2B/W** is in the lowermost position.

[0081] For each photodiode array **2R**, **2G**, **2B**, **2B/W**, there maybe defined a respective center line **510R**, **510G**, **510B**, **510B/W**. The photodiode arrays **2R**, **2G**, **2B**, **2B/W** may be aligned in the main scanning direction **250**, such that the center lines **510R**, **510G**, **510B**, **510B/W** are parallel to the main scanning direction **250**.

[0082] The photodiode arrays **2R**, **2G**, **2B**, **2B/W** may be spaced at respective intervals **561**, **562**, **563**, and disposed in positions relative one another as shown. In the sub-scanning direction **260**, the intervals between the center lines **510R**, **510G**, **510B**, **510B/W** may be an integral multiple of the reading pitch. The reading pitch may be determined by the product of the moving speed of a carriage of a scanner in the reading mechanical system **260** (**FIG. 2**) and the period of time of SH-R, SH-G, SH-B, and SH-B/W.

[0083] As shown in the figures, the photodiode arrays **2R**, **2G**, **2B**, **2B/W** include a number of photodiodes **570R**, **570G**, **570B**, **570B/W**, each corresponding to a pixel. (Although the figures may appear to show the photodiode arrays each having a large central portion, this is intended to represent an undefined number of photodiodes.) The photodiodes **570R**, **570G**, **570B**, **570B/W** have respective light receiving surfaces. The light receiving surfaces of the color photodiodes **570R**, **570G**, **570B** may have uniform height **530R**, **530G**, **530B**. The individual light receiving surfaces of the monochrome photodiodes **570B/W** may have a uniform height **530B/W**.

[0084] The light receiving surfaces of each respective photodiode **570R**, **570G**, **570B**, **570B/W** have a size and shape. The light receiving surfaces of the color photodiodes **570R**, **570G**, **570B** may have a uniform width **540**. The individual light receiving surfaces of the monochrome photodiodes **570B/W** may have a uniform width **550**. The size and shape of the light receiving area may be one determinant of a photodiode's sensitivity.

[0085] Each light receiving surface of the photodiodes **570R**, **570G**, **570B**, **570B/W** defines an area. In the first

embodiment, the area of the monochrome photodiodes **570B/W** is $\frac{1}{4}$ of the light receiving area of the color photodiodes **570R**, **570G**, **570B**. The area of the color photodiodes **570R**, **570G**, **570B** may be the same.

[**0086**] The light receiving surfaces of the photodiodes **570R**, **570G**, **570B**, **570B/W** may have the shape of a square. Accordingly, the width **540** may be twice the width **550**, and the height **530R**, **530G**, **530B** may be twice the height **530B/W**. Therefore, there may be twice as many photodiodes in the monochrome photodiode array **2B/W** as in any one of the color photodiode arrays **2R**, **2G**, **2B**.

[**0087**] Because of the relative sizes of the areas of the photodiodes **570R**, **570G**, **570B**, **570B/W** and because of the timing of the output signals described with respect to **FIG. 4**, the resolution of the monochrome output signals B/W Output 1, B/W Output 2 is twice that of the color output signals R Output, G Output, B Output in both the main scanning direction **250** and the sub-scanning direction **260**.

[**0088**] For example, consider an image reading apparatus wherein the number of photodiodes (i.e., pixels) of the monochrome photodiode array **2B/W** is 7500. Such an embodiment is shown in the timing chart of **FIG. 6**. The stored charges of the 1st to 3750th color photodiodes **570R**, **570G**, **570B** are sequentially output as signals R Output, G Output, B Output. The stored charges of the 1st, 3rd, ---, and 7499th (odd numbered) photodiodes are sequentially output as B/W Output 1. The stored charges of the 2nd, 4th, ---, and 7500th (even numbered) photodiodes are sequentially output as B/W Output 2. The monochrome shift signal SH-B/W may have a cycle which is $\frac{1}{2}$ of the cycle of the color shift signals SH-R, SH-G, SH-B. Thus, at every other monochrome shift signal SH-B/W, there is no R Output, G Output, B Output.

[**0089**] Referring now to **FIG. 7**, there is shown an outline of a color scanning process of the first embodiment. Despite the fact that the photodiode arrays **2R**, **2G**, **2B**, **2B/W** are linear and one-dimensional (in the main scanning direction **250**), a two dimensional image is obtained by combining image data obtained along the sub-scanning direction **260** (e.g., raster scanned). Thus, the one-dimensional photodiode arrays **2R**, **2G**, **2B**, **2B/W** may be viewed as two-dimensional arrays **710**, **720** each having a row dimension and a column dimension.

[**0090**] Because the monochrome photodiode array **2B/W** is clocked at twice the rate of the color photodiode arrays **2R**, **2G**, **2B**, the two-dimensional view **710** of the monochrome photodiode array **2B/W** has twice as many rows as the two-dimensional view **720** of the color photodiode arrays **2R**, **2G**, **2B**.

[**0091**] For convenience, the rows of the monochrome photodiode array **2B/W** will be labeled with the variable "i" and the rows of color photodiode arrays **2R**, **2G**, **2B** will be labeled with the variable "k". The columns of the color photodiode arrays **2R**, **2G**, **2B** will be labeled with the variable "l". The columns of the monochrome photodiode array **2B/W** will be labeled with the variable "j". Each pixel of the pixel data is identified by a row and column position, wherein the row corresponds to the main scanning direction **250**, and the column corresponds to the sub-scanning direction **260**.

[**0092**] The monochrome pixel data is referred to as K and individual pixel data is referred to by row, column as K(i, j).

Likewise, the color pixel data is referred to as R(k, l), G(k, l), and B(k, l). Because the monochrome pixels are half as wide and half as high as the color pixels, for each color pixel R(k, l), G(k, l), and B(k, l) there are four monochrome pixels, at K(2k, 2l-1), K(2k-1, 2l-1), K(2k, 2l) and K(2k-1, 2l). The monochrome pixels at K(2k, 2l-1) and K(2k-1, 2l-1) may be considered on odd-numbered lines. The monochrome pixels at K(2k, 2l) and K(2k-1, 2l) may be considered on even-numbered lines.

[**0093**] Referring now to **FIG. 8**, there is shown a block diagram of a color signal correction unit **800** of the first embodiment. The color signal correction unit **835** has a CrCb calculation circuit **830**, an RGB resolution correction circuit **831**, a parameter storage memory **832**, three one-pixel delay buffers **833**, **834**, **837**, a delay line memory **836**, and a data selector **835**. Before correction by the color signal correction unit **800**, the number of pixels in the sub-scanning direction **260** the monochrome data is twice that of the color data, and the number of pixels in the main scanning direction **250** of the monochrome data is twice that of the color data. The color signal correction unit **800** uses information in the monochrome signals to enhance the color signals. Thus, the color signal correction unit **800** may output color signals having the same number of pixels as the monochrome signals in both the main scanning direction **250** and the sub-scanning direction **260**.

[**0094**] As shown at the top of **FIG. 8**, the color pixel data R(k, l), G(k, l), B(k, l), the even channels of the monochrome pixel data K(2k, 2l-1) (odd lines), K(2k, 2l) (even lines) and the odd channel of the monochrome pixel data K(2k-1, 2l-1) (odd lines), K(2k-1, 2l) (even lines) may be input at the same time to the color signal correction unit **800**.

[**0095**] The CrCb calculation circuit **830** and the one-pixel delay buffers **833**, **837** perform a YCrCb conversion indicated in Formulas (1) to (6). Namely, they produce a brightness signal (Y), a first color difference signal (Cr=R-Y), and a second color difference signal (Cb=B-Y).

[**0096**] The monochrome signal K can be directly used as the brightness signal Y. As shown in **FIG. 6**, the monochrome signal K has signals for the even-numbered pixels and signals for the odd-numbered pixels. The odd channel of the odd lines of the input monochrome signal K(i, j)=K(2k-1, 2l-1). The even channel of the odd lines of the input monochrome signal K(i, j)=K(2k, 2l-1). The odd channel of the even lines of the input monochrome signal K(i, j)=K(2k-1, 2l). The even channel of the even lines of the input monochrome signal K(i, j)=K(2k, 2l). These four signals satisfy Formulas (1) through (4) for the brightness signals. The odd channel signals are input directly to the RGB resolution correction circuit **831**. The even channel signals are delayed by a one-pixel period via the one-pixel delay buffers **833**, **837** and then input to the RGB resolution correction circuit **831**. This delay results in the even channel signals being interleaved with the odd channel signals as input to the RGB resolution correction circuit **831**.

$$Y(2k-1, 2l-1)=K(2k-1, 2l-1) \quad (1)$$

$$Y(2k, 2l-1)=K(2k, 2l-1) \quad (2)$$

$$Y(2k-1, 2l)=K(2k-1, 2l) \quad (3)$$

$$Y(2k, 2l)=K(2k, 2l) \quad (4)$$

[**0097**] The parameter storage memory **832** stores parameters, including a_{r0} , a_{g0} , a_{b0} , a_{r1} , a_{g1} , a_{b1} , b_{r0} , b_{g0} , b_{b0} , b_{r1} ,

b_{g1} , and b_{b1} . These parameters are determined by the characteristics of the CCD and light source.

[0098] The first color difference signal Cr and the second color difference signal Cb can be obtained from the color signals R, G, B even if there is no brightness signal Y. This is shown in Formulas (5) and (6). The CrCb calculation circuit **830** calculates Formulas (5) and (6) using the parameters a_{r0} , a_{g0} , a_{b0} , a_{r1} , a_{g1} , and a_{b1} , thereby obtaining the pixel data Cr(k, j) of the first color difference signal and the pixel data Cb(k, j) of the second color difference signal. The CrCb calculation circuit **830** inputs the pixel data Cr(k, j), Cb(k, j) to the RGB resolution correction circuit **831**.

$$Cr(k,l)=a_{r0}R(k,l)+a_{g0}G(k,l)+a_{b0}B(k,l) \quad (5)$$

$$Cb(k,l)=a_{r1}R(k,l)+a_{g1}G(k,l)+a_{b1}B(k,l) \quad (6)$$

[0099] The RGB resolution correction circuit **831** executes the RGB reverse conversion using Formulas (7) to (18) and obtains three primary colors R', G', B' with increased resolution (the number of pixels) in the main scanning direction **250**. The RGB resolution correction circuit **831** obtains the parameters b_{r0} , b_{g0} , b_{b0} , b_{r1} , b_{g1} , and b_{b1} from the parameter storage memory **832**.

$$R'(2k-1,2l-1)=Y(2k-1,2l-1)+br0Cr(k,l) \quad (7)$$

$$G'(2k-1,2l-1)=Y(2k-1,2l-1)-br1Cr(k,l)+bb0Cb(k,l) \quad (8)$$

$$B'(2k-1,2l-1)=Y(2k-1,2l-1)+bb1Cb(k,l) \quad (9)$$

$$R'(2k,2l-1)=Y(2k,2l-1)+br0Cr(k,l) \quad (10)$$

$$G'(2k,2l-1)=Y(2k,2l-1)-br1Cr(k,l)+bb0Cb(k,l) \quad (11)$$

$$B'(2k,2l-1)=Y(2k,2l-1)+bb1Cb(k,l) \quad (12)$$

$$R'(2k-1,2l)=Y(2k-1,2l)+br0Cr(k,l) \quad (13)$$

$$G'(2k-1,2l)=Y(2k-1,2l)-br1Cr(k,l)+bb0Cb(k,l) \quad (14)$$

$$B'(2k-1,2l)=Y(2k-1,2l)+bb1Cb(k,l) \quad (15)$$

$$R'(2k,2l)=Y(2k,2l)+br0Cr(k,l) \quad (16)$$

$$G'(2k,2l)=Y(2k,2l)-br1Cr(k,l)+bb0Cb(k,l) \quad (17)$$

$$B'(2k,2l)=Y(2k,2l)+bb1Cb(k,l) \quad (18)$$

[0100] The brightness signal Y, the first color difference signal Cr, and the second color difference signal Cb can be converted to the three primary color signals R', G', B'. In the first embodiment, the number of pixels of the brightness signal Y in the main scanning direction **250** is twice the number of pixels of the first color difference signal Cr and the second color difference signal Cb in the main scanning direction **250**. After conversion, the number of pixels of the color signals R', G', B' in the main scanning direction **250** is the same as the number of pixels of the brightness signal Y before conversion.

[0101] Formulas (7) to (9) and (13-15) are expressions of data at the even pixel positions of the color signals R', G', B' after conversion. Formulas (10) to (12) and (16) to (18) are expressions of data at the odd pixel positions of the color signals R', G', B' after conversion. The RGB resolution correction circuit **831** calculates Formulas (7) to (9) and (13-15) almost in parallel using the parameters b_{r0} , b_{r1} , b_{b0} , and b_{b1} obtained from the parameter storage memory **832**.

[0102] The four outputs of the RGB resolution correction circuit **831** may be treated differently. The RGB resolution correction circuit **831** gives the color signals R'(2k-1, 2l-1), G'(2k-1, 2l-1), B'(2k-1, 2l-1) at the odd line and odd pixel positions to the data selector **835** as a first selection input. The RGB resolution correction circuit **831** gives the color signals R'(2k, 2l-1), G'(2k, 2l-1), B'(2k, 2l-1) at the odd

line and even pixel positions to the delay buffer **834**. The delay buffer **834** adds a one-pixel delay and gives the signals to the data selector **835** as a second selection input. The RGB resolution correction circuit **831** gives the color signals R'(2k-1, 2l), G'(2k-1, 2l), B'(2k-1, 2l) at the even line and odd pixel positions, and the color signals R'(2k, 2l), G'(2k, 2l), B'(2k, 2l) at the even line and even pixel positions, to the delay line memory **836**. The delay line memory **836** adds a one line delay and then feeds the signals to the data selector **835**. As a result, the four signals are synchronized at the data selector **835**.

[0103] Further, FIG. 8 shows a case that even in the color mode, the brightness signal (that is, the monochrome signal K(i, j)) is output from the color signal correction unit **800**.

[0104] The data selector **835**, according to an odd/even line discrimination signal **845** and an odd/even pixel discrimination signal **840** from the timing generation circuit **800**, selects and outputs R'(i, j), G'(i, j), B'(i, j).

[0105] A-2 Operation of the First Embodiment

[0106] In the image reading apparatus **300** shown in FIG. 3, the control unit **360**, upon receipt of an instruction of document reading in the color mode from the control panel **365**, turns on the white lamp **380**, drives the reading mechanical system by the driving unit **375**, and indirectly or directly starts the electrical processing system such as the image sensor unit **310**, the analog processing unit **315**, the A-D conversion circuit **320**, the shading correction unit **325**, the inter-line correction circuit **330**, the color signal correction unit **335**, and the page memory **340** via the timing generation circuit **355**.

[0107] Further, the moving speed of the reading mechanical system **210** in the sub-scanning direction **260** in the color mode may be the same as that in the monochrome mode.

[0108] Referring now to FIG. 9, there is shown a first timing chart showing the operation of the image sensor unit **400**. In the image sensor unit **400**, the charges stored in the photodiode arrays **2R**, **2G**, **2B** are shifted to the shift registers **4R**, **4G**, **4B** according to the shift instruction signals SH-R, SH-G, SH-B. During the period of next photoelectric conversion and charge storage of the photodiode arrays **2R**, **2G**, **2B**, the stored charges are serially output from the shift registers **4R**, **4G**, **4B** according to the clock signal **420**. The stored charges then are given to the analog processing unit **315** sequentially via the reset gates **5R**, **5G**, **5B**, the clamp circuits **6R**, **6G**, **6B**, and the amplifiers **7R**, **7G**, **7B**.

[0109] Referring now to FIG. 10, there is shown a second timing chart showing the operation of the image sensor unit **400**. The reset signal **440** is given to the reset gates **5R**, **5G**, **5B** during the first half of the significant pulse period of the clock signal **420**. This separates the inter-pixel signals. The clamp signal **450** is given to the clamp circuits **6R**, **6G**, **6B** during the second half of the significant pulse period of the clock signal **420**, and the read pixel signals are clamped.

[0110] The charges stored in the monochrome photodiode array **2B/W** are shifted to the shift registers **4B/WO**, **4B/WE** according to the shift instruction signal SH-B/W. During the period of next photoelectric conversion and charge storage of the photodiode array **2B/W**, the charges are serially output from the shift registers **4B/WO**, **4B/WE** according to the

clock signal **420**. The charges are then given respectively to the analog processing unit **315** sequentially via the reset gates SB/WO, 5B/WE, the clamp circuits 6B/WO, 6B/WE, and the amplifiers 7B/WO, 7B/WE.

[0111] The shift instruction signal SH-B/W may have a cycle which is $\frac{1}{2}$ of the cycle of the color shift instruction signals SH-R, SH-G, SH-B. As shown in FIG. 9, when the monochrome output signals B/W Output 1, B/W Output 2 are output in the sub-scanning direction **260** in correspondence to two lines, the color output signals R Output, G Output, B Output are output in the sub-scanning direction **260** in correspondence to one line.

[0112] As mentioned above, the output signals R Output, G Output, B Output, B/W Output 1, B/W Output 2 are subject to level shift, noise removal, and amplification by the analog processing unit **315** and then converted to digital signals **321**, **322** by the A-D conversion circuit **320**. Further, the two monochrome signals B/W Output 1, B/W Output 2 are also unified to a 1-channel signal **322**. Thereafter, the signals are subject to shading correction for illumination variations by the shading correction unit **325**.

[0113] The inter-line correction circuit **330** converts the signals **326** to signals fit to the three-primary colors R, G, B and monochrome lines, in consideration of different positions of the photodiode arrays **2R**, **2G**, **2B**, **2B/W** in the sub-scanning direction **260**. The inter-line correction circuit **330** also may convert the color signals to double density signals in the sub-scanning direction **260**.

[0114] The color signals from the color signal correction unit **335** are stored once in the page memory **340** and then read or directly given to the output image processing unit **350**, subject to the image process according to the output form, and outputted from the image reading apparatus **300**.

[0115] The image reading operation in the monochrome mode, even if a color signal is output from the image sensor unit **310**, effectively functions only the processing system for a monochrome signal.

[0116] A-3 Effects of the First Embodiment

[0117] Color filters may damp the amount of light received by the color arrays. In the image sensor unit **310** of the first embodiment, the light receiving area of the photodiodes of the color arrays **2R**, **2G**, **2B** is made wider than the light receiving area of the photodiodes of the monochrome array **2B/W**. As a result, despite the damped light, good resolution may be obtained. Despite the increased width, the image sensor unit **310** is simple and compact. As a result, a decrease in cost can be obtained.

[0118] By including the monochrome photodiode array **2B/W**, image quality in monochrome mode is also good.

[0119] Furthermore, the light receiving area of each color photodiode is wide, so that even if the process is performed at a speed in the sub-scanning direction **260** in color mode which is equal to the speed in the sub-scanning direction **260** in monochrome mode, the reduction in the color image quality can be minimized. This matter (single speed) means that the moving mechanism in the sub-scanning direction **260** and the driving unit therefore can be simplified.

[0120] Such an image quality reduction due to the same speed can be corrected by the correction processes of the

inter-line correction circuit **330** and the color signal correction unit **335**. Thus, a sufficiently good color image quality can be obtained. Particularly, the color signal correction unit **335** adopts a new idea of using, for correction of a color signal, information of a monochrome signal having a higher resolution than that of the color signal.

[0121] Furthermore, the light receiving area of each color photodiode is wide and moreover the aforementioned correction process by the color signal correction unit **335** is performed. When an automatic document feeder (ADF) is used, paper moves across the glass, and the paper may incline, bend or detach from the original glass **220** (FIG. 2). As might be expected, these deviations may easily cause deviation in the image scan quality, such as differences amongst and amid the color signals **311** and monochrome signals **312** (FIG. 3). However, by increasing the light receiving area of each color photodiode, the influence of the deviations will be decreased, so that an improvement of the color through-pass read characteristic can be expected.

[0122] (B) Second Embodiment

[0123] Next, the second embodiment of the image sensor unit and image reading apparatus of the present invention will be explained briefly with reference to the accompanying drawings. The image sensor unit and image reading apparatus of the second embodiment will be explained hereunder centering on the differences from those of the first embodiment.

[0124] Referring now to FIG. 11, there is shown a block diagram of an image sensor unit **1100** of the second embodiment. The image sensor unit **1100** has the same and corresponding parts as those of the image sensor unit **400** of the first embodiment shown in FIG. 4, so the same and corresponding reference numbers are assigned. The position of the image sensor unit **1100** to the whole image reading apparatus is shown in FIG. 3 in the same way as with the image sensor unit **400** of the first embodiment.

[0125] In the second embodiment, the relationship between the light receiving surface of the photodiodes of the color photodiode arrays **2R**, **2G**, **2B** and the light receiving surface of the photodiodes of the monochrome photodiode array **2B/W** is different than in the first embodiment.

[0126] Referring now to FIG. 12, there is shown a diagram of the photodiode arrays **2R**, **2G**, **2B**, **2B/W** of FIG. 11. As shown in the figures, the photodiode arrays **2R**, **2G**, **2B**, **2B/W** include a number of photodiodes **1270R**, **1270G**, **1270B**, **1270B/W**. (Although the figures may appear to show the photodiode arrays each having a large central portion, this is intended to represent an undefined number of photodiodes.) The photodiodes **1270R**, **1270G**, **1270B**, **1270B/W** have respective light receiving surfaces.

[0127] The light receiving surfaces of each respective photodiode **1270R**, **1270G**, **1270B**, **1270B/W** have a size and shape. The light receiving surfaces of the color photodiodes **1270R**, **1270G**, **1270B** may have a uniform width **1240**. The individual light receiving surfaces of the monochrome photodiodes **1270B/W** may have a uniform width **1250**. The light receiving surfaces of the color photodiodes **1270R**, **1270G**, **1270B** may have uniform height **1230R**, **1230G**, **1230B**. The individual light receiving surfaces of the monochrome photodiodes **1270B/W** may have a uniform height **1230B/W**.

[0128] Each light receiving surface of the photodiodes **1270R**, **1270G**, **1270B**, **1270B/W** defines an area. In the second embodiment, the area of the monochrome photodiodes **1270B/W** is 1/2 of the light receiving area of the color photodiodes **1270R**, **1270G**, **1270B**. The area of the color photodiodes **1270R**, **1270G**, **1270B** may be the same.

[0129] The light receiving surfaces of the photodiodes **1270B/W** may have the shape of a square. The light receiving surfaces of the photodiodes **1270R**, **1270G**, **1270B** may have the shape of a rectangle. The width **1240** may be twice the width **1250**. The height **1230R**, **1230G**, **1230B** may be equal to the height **1230B/W**. Therefore, there may be twice as many photodiodes in the monochrome photodiode array **2B/W** as in any one of the color photodiode arrays **2R**, **2G**, **2B**.

[0130] For each photodiode array **2R**, **2G**, **2B**, **2B/W**, there may be defined a respective center line **1210R**, **1210G**, **1210B**, **1210B/W**. The photodiode arrays **2R**, **2G**, **2B**, **2B/W** may be aligned in the main scanning direction **250**, such that the center lines **1210R**, **1210G**, **1210B**, **1210B/W** are parallel to the main scanning direction **250**.

[0131] The photodiode arrays **2R**, **2G**, **2B**, **2B/W** may be spaced at respective intervals **1261**, **1262**, **1263**, and disposed in positions relative one another as shown. In the sub-scanning direction **260**, the intervals between the center lines **1210R**, **1210G**, **1210B**, **1210B/W** may be an integral multiple of the reading pitch.

[0132] Referring now to **FIG. 13**, there is shown a timing chart showing the operation of the image sensor unit **1100** of the second embodiment. **FIG. 13** shows a case that the number of photodiodes (the number of pixels in the main scanning direction) of the monochrome photodiode array **2B/W** is 7500.

[0133] The timing generation circuit **335** (**FIG. 3**) gives the shift instruction signals **SH-R**, **SH-G**, **SH-B**, **SH-B/W** to the image sensor unit **1100**. The shift instruction signals **SH-R**, **SH-G**, **SH-B**, **SH-B/W** may be the same. The timing generation circuit **335** gives a common clock signal **1120** to the shift registers **4R**, **4G**, **4B**, **4B/WO**, **4B/WE**.

[0134] In the second embodiment, the resolution of the monochrome output signals **B/W Output 1**, **B/W Output 2** from the image sensor unit **1100** is twice the resolution of the color output signals (**R Output**, **G Output**, **B Output**).

[0135] In the second embodiment, the process of the inter-line correction circuit **330** is slightly different from that of the first embodiment. The processes of the other circuits **315**, **320**, **325**, **335**, **340**, **350** are almost the same as those of the first embodiment. In the second embodiment, the inter-line correction circuit **330** does not perform an interpolation process of doubling the number of lines (resolution) in the sub-scanning direction **260** for the color output.

[0136] Referring now to **FIG. 33**, there is shown a block diagram of a color signal correction unit **3300** of the second embodiment. **FIG. 34** is a schematic explanatory diagram of the process of the color signal correction unit **3300**. Monochrome signals and color signals represented by the same number of bits are input to the color signal correction unit **3300**.

[0137] In **FIG. 33**, the color signal correction unit **3300** has a CrCb calculation circuit **3330**, an RGB resolution

correction circuit **3331**, a parameter storage memory **3332**, one-pixel delays **3336**, **3337**, and a data selector **3335**.

[0138] The color signal correction unit **3300** receives the monochrome pixel data **K(i, j)** in the relation shown in parts A and B of **FIG. 34** and the color pixel data **R(k, j)**, **G(k, j)**, **B(k, j)** in parallel.

[0139] The CrCb calculation circuit **3330** and the one-pixel delay buffer **3337** perform a YCrCb conversion indicated in Formulas (19) to (22). The CrCb calculation circuit **3330**, uses the color pixel data **R(k, j)**, **G(k, j)**, **B(k, j)** and the parameters a_{r0} , a_{g0} , a_{b0} , a_{r1} , a_{g1} , and a_{b1} stored in the parameter storage memory **3332**.

$$Y(2k-1, j) = K(2k-1, j) \tag{19}$$

$$Y(2k, j) = K(2k, j) \tag{20}$$

$$Cr(k, j) = a_{r0}R(k, j) + a_{g0}G(k, j) + a_{b0}B(k, j) \tag{21}$$

$$Cb(k, j) = a_{r1}R(k, j) + a_{g1}G(k, j) + a_{b1}B(k, j) \tag{22}$$

[0140] The RGB resolution correction circuit **3331** executes the RGB reverse conversion meeting Formulas (23) to (28) using the parameters b_{r0} , b_{r1} , b_{b0} , and b_{b1} stored in the parameter storage memory **3332** and obtains three primary colors **R'**, **G'**, **B'** with the resolution (the number of pixels) in the main scanning direction **250** increased.

$$R'(2k-1, j) = K(2k-1, j) + b_{r0}Cr(k, j) \tag{23}$$

$$G'(2k-1, j) = K(2k-1, j) - b_{r1}Cr(k, j) + b_{b0}Cb(k, j) \tag{24}$$

$$B'(2k-1, j) = K(2k-1, j) + b_{b1}Cb(k, j) \tag{25}$$

$$R'(2k, j) = K(2k, j) + b_{r0}Cr(k, j) \tag{26}$$

$$G'(2k, j) = K(2k, j) - b_{r1}Cr(k, j) + b_{b0}Cb(k, j) \tag{27}$$

$$B'(2k, j) = K(2k, j) + b_{b1}Cb(k, j) \tag{28}$$

[0141] The one-pixel delay **3336** may delay the signals **K'(2k, j)**, **R'(2k, j)**, **G'(2k, j)**, **B'(2k, j)** from the RGB resolution correction circuit **3331** by one pixel period, and then may give the signals to the data selector **3335** as a first selection input. The RGB resolution correction circuit **3331** may give the obtained signals **K'(2k-1, j)**, **R'(2k-1, j)**, **G'(2k-1, j)**, **B'(2k-1, j)** to the data selector **3335** as a second selection input. **FIG. 33** shows a case that even in the color mode, the brightness signal, that is, the monochrome signal **K'(i, j)** is output from the color signal correction unit **3300**.

[0142] The data selector **3335**, according to a discrimination signal **3340** (indicated as Odd/Even line discrimination signal in **FIG. 33**) from the timing generation circuit **335**, selects and outputs **K'(i, j)**, **R'(i, j)**, **G'(i, j)**, **B'(i, j)**.

[0143] By the image sensor unit **1100** of the second embodiment and the image reading apparatus adopting it, almost the same effects as those of the first embodiment can be obtained.

[0144] In addition to it, the light receiving surface of each photodiode of the color photodiode arrays are short in the sub-scanning direction **260**, so that further miniaturization of the one-dimensional image sensor unit **1100** and a further decrease in cost can be expected. Even in this case, the color resolution in the main scanning direction **250** is improved by the function of the color signal correction unit **335**.

[0145] (C) Third Embodiment

[0146] Referring now to **FIG. 14**, there is shown a block diagram of an image sensor unit **1400** of a third embodiment. In **FIG. 14**, the same and corresponding numerals are

assigned to the same and corresponding parts as those of the image sensor unit **400** of the first embodiment.

[0147] The position of the image sensor unit **1400** to the whole image reading apparatus is the position shown in **FIG. 3** in the same way as with the image sensor unit **400** of the first embodiment.

[0148] In the image sensor unit **1400**, the relationship between the light receiving surface of each photodiode of the photodiode arrays **2R**, **2G**, **2B** for the three primary colors R, G, B and the light receiving surface of each photodiode of the monochrome photodiode array **2B/W** may be the same as that of the first embodiment.

[0149] The difference of the image sensor unit **1400** from that of the first embodiment is a constitution for outputting the stored charge of the monochrome photodiode array **2B/W**. In particular, instead of the monochrome shift registers **4B/WO**, **4B/WE** of the first embodiment, the third embodiment has shift registers **4B/WS** and **4B/WB**. The shift register **4B/WS** receives and stores the charges of the photodiodes in the low arrangement order of the photodiode array **2B/W**. The shift register **4B/WB** receives and stores the charges of the photodiodes in the high arrangement order of the photodiode array **2B/W**. Instead of having two shift gates as in the first embodiment, a single shift gate **3B/W** transfers and controls the stored charge of the photodiode array **2B/W** to the shift registers **4B/WS** and **4B/WB**.

[0150] The third embodiment handles the signals from the shift registers **4B/WS** and **4B/WB** similarly to the first embodiment. Thus, there are also reset gates **5B/WS**, **5B/WB**, clamp circuits **6B/WS**, **6B/WB** and amplifiers **7B/WS**, **7B/WB**.

[0151] In the third embodiment, the processing system for reading image signals after the analog processing unit **315** is almost the same as that of the first embodiment.

[0152] The monochrome outputs B/W Output 1, B/W Output 2 from the image sensor unit **1400** may be in the ascending order and descending order as shown in **FIG. 15**. If so, then the process of unifying the monochrome signals of the two channels to a monochrome signal of one channel is somewhat different from that of the first embodiment.

[0153] By the image sensor unit **1400** and the image reading apparatus adopting it, almost the same effects as those of the first embodiment can be obtained. In addition to it, the two shift registers **4B/WS** and **4B/WB** and the shift gate **3B/W** may be arranged only in the up-down direction of the photodiode array **2B/W**, so that further miniaturization of the image sensor unit **1400** and a further decrease in cost can be expected.

[0154] (D) Fourth Embodiment

[0155] Referring now to **FIG. 16**, there is shown a block diagram of an image sensor unit **1600** of a third embodiment. In **FIG. 16**, the same and corresponding numerals are assigned to the same and corresponding parts as those of the image sensor unit **400** of the first embodiment.

[0156] In the image sensor unit **1600**, the relationship between the light receiving surface of each photodiode of the color photodiode arrays **2R**, **2G**, **2B** and the light receiving surface of each photodiode of the monochrome photodiode array **2B/W** may be the same as that of the first embodiment.

[0157] In the first embodiment, the image sensor unit **400** has two shift registers **4B/WO**, **4B/WE** for the monochrome photodiode array **2B/W**. In contrast, the fourth embodiment has four monochrome shift registers **4B/WOB**, **4B/WOS**, **4B/WEB**, **4B/WES**. The shift register **4B/WOS** stores charges of the low-order odd numbered photodiodes. The shift register **4B/WOB** stores charges of the high-order odd numbered photodiodes. The shift register **4B/WES** stores charges of the low-order even numbered photodiodes. The shift register **4B/WEB** stores charges of the high-order even numbered photodiodes.

[0158] Further, in correspondence with installation of the four shift registers **4B/WOS**, **4B/WOB**, **4B/WES**, **4B/WEB**, four reset gates **5B/WOS**, **5B/WOB**, **5B/WES**, **5B/WEB**, four clamp circuits **6B/WOS**, **6B/WOB**, **6B/WES**, **6B/WEB**, and four amplifiers **7B/WOS**, **7B/WOB**, **7B/WES**, **7B/WEB** are included.

[0159] The fourth embodiment processes the image signals after the analog processing unit **315** almost the same as that in the first embodiment. However, to accommodate the four channels of monochrome output B/W Output 1, B/W Output 2, B/W Output 3, B/W Output 4, the analog processing unit **315** and the A-D conversion circuit **320** have a 4-channel processing system for monochrome signals.

[0160] The monochrome output B/W Output 1, B/W Output 2, B/W Output 3, B/W Output 4 may be in ascending order and descending order as shown in **FIG. 17**. If so, then the A-D conversion circuit **320** may unify the converted four-channel monochrome signals to a 1-channel monochrome signal in consideration of the arrangement order.

[0161] By the image sensor unit **1600** and the image reading apparatus adopting it, almost the same effects as those of the first embodiment can be obtained. In addition, reading from the image sensor unit **1600** is executed by a plurality of channels for the monochrome photodiode arrays, so that speeding up of the reading speed can be expected.

[0162] (E) Fifth Embodiment

[0163] Referring now to **FIG. 18**, there is shown a block diagram of an image sensor unit **1800** of a fifth embodiment. In **FIG. 18**, the same and corresponding numerals are assigned to the same and corresponding parts as those of the image sensor units **400**, **1600** of the first and fourth embodiments.

[0164] In the image sensor unit **1800**, the relationship between the light receiving surface of each photodiode of the color photodiode arrays **2R**, **2G**, **2B** and the light receiving surface of each photodiode of the monochrome photodiode array **2B/W** is the same as that of the first embodiment. In the same way as with the fourth embodiment, there is a four-channel constitution for outputting the stored charge of the monochrome photodiode array **2B/W**. However, the color photodiode arrays **2R**, **2G**, **2B** each have a two-channel output. The two output channels from each photodiode array **2R**, **2G**, **2B** come from respective low-order and high-order numbered photodiodes.

[0165] shift registers **4RS**, **4GS**, **4BS** store charges of the low-order photodiodes. shift registers **4RB**, **4GB**, **4BB** store charges of the high-order photodiodes. The shift gates **3R**, **3G**, **3B** operate common to the two channels.

[0166] In correspondence with the shift registers 4RS, 4GS, 4BS, 4RB, 4GB, 4BB there are reset gates 5RS, 5GS, 5BS, 5RB, 5GB, 5BB, clamp circuits 6RS, 6GS, 6BS, 6RB, 6GB, 6BB, and amplifiers 7RS, 7GS, 7BS, 7RB, 7GB, and 7BB.

[0167] The processing for image signals after the analog processing unit 315 is almost the same as that of the first embodiment.

[0168] In the fifth embodiment, the analog processing unit 315 and the A-D conversion circuit 320 have two-channel processing system for the color signals and four-channel processing system for the monochrome signals. The output signals from the image sensor unit 1800 may be as shown in FIG. 19. The A-D conversion circuit 320 may unify the converted two-channel color signals to one-channel color signals. The A-D conversion circuit 320 may unify the converted four-channel monochrome signals to one-channel monochrome signal.

[0169] By the image sensor unit 1800 and the image reading apparatus adopting it, almost the same effects as those of the first embodiment can be obtained. In addition, reading from the image sensor unit 1800 is executed by a plurality of channels for the respective photodiode arrays, so that speeding up of the reading speed can be expected.

[0170] (F) Sixth Embodiment

[0171] Referring now to FIG. 20, there is shown a block diagram of an image sensor unit 2000 of a sixth embodiment. In FIG. 20, the same and corresponding numerals are assigned to the same and corresponding parts as those of the image sensor units 400 of the first embodiment.

[0172] The position of the one-dimensional image sensor unit 2000 to the whole image reading apparatus is the position shown in FIG. 3 in the same way as with the image sensor unit 400 of the first embodiment.

[0173] In the image sensor unit 2000, the relationship between the light receiving surface of each photodiode of the color photodiode arrays 2R, 2G, 2B and the light receiving surface of each photodiode of the monochrome photodiode array 2B/W is the same as that of the first embodiment. However, in the image sensor unit 2000, the color constitution and monochrome constitution are formed on the same chip independently of each other.

[0174] The color constitution may be the same as that of the first embodiment, so that the explanation therefore will be omitted.

[0175] The monochrome constitution is different from that of the first embodiment. Namely, the shift gate 3B/W, shift register 4B/W, reset gate 5B/W, clamp circuit 6B/W, and amplifier 7B/W have a one-channel constitution.

[0176] Further, a clock signal (Clock 1) to the monochrome shift register 4B/W and a clock signal (Clock 2) to the shift registers 4R, 4G, 4B for the three primary colors R, G, and B can be optionally given independently of the outside (e.g., the timing generation circuit 355) of the image sensor unit 2000.

[0177] Further, the monochrome output is of a one-channel constitution, so that the monochrome processing system of the analog processing unit 315 and the A-D conversion circuit 320 may be of a one-channel constitution and the A-D

conversion circuit 320 does not need to perform a process of unifying a plurality of monochrome channels.

[0178] In the image sensor unit 2000, the color constitution and monochrome constitution are formed independently of each other, so that an image reading apparatus incorporating them can be designed optionally. For example, a constitution of processing only signals of the three primary colors R, G, B from the image sensor unit 2000 in the color mode and processing only a monochrome signal from the image sensor unit 2000 in the monochrome mode may be used. In this case, the color signal correction unit 335 may be omitted.

[0179] Further, for example, as shown in FIG. 21, in the color mode, a constitution of reducing the reading speed of signals of the three primary colors R, G, B in the main scanning direction to 1/2 of the reading speed of a monochrome signal in the main scanning direction may be used. In this case, depending on the selected clock cycle, the processing system after the shading correction unit 325 may be structured exactly in the same way as with the first embodiment.

[0180] Furthermore, for example, even in the color mode having a function for improving the resolution of color signals using information of monochrome signals, a double reading method for firstly reading only monochrome signals and then reading color signals (three-primary color signals) may be adopted.

[0181] In the image sensor unit 2000, the color constitution and monochrome constitution are formed independently of each other, so that the degree of designing freedom of an image reading apparatus can be increased. Depending on the design contents, the same effects as those of the first embodiment can be produced.

[0182] (G) Seventh Embodiment

[0183] FIG. 22 is a block diagram showing the constitution of an image sensor unit 2200 of a seventh embodiment and to the same and corresponding parts as those shown in FIG. 4 relating to the first embodiment, the same and corresponding numerals are assigned. The position of the image sensor unit 2200 to the whole image reading apparatus is the position shown in FIG. 3 in the same way as with the image sensor unit 400 of the first embodiment.

[0184] In the image sensor unit 2200, the color photodiode arrays 2R, 2G, 2B and the monochrome photodiode array 2B/W may have the same number of photodiodes (the same number of pixels). However, two outputs R Output 1, R Output 2, G Output 1, G Output 2, B Output 1, B Output 2 from each color photodiode array may be obtained. Thus, for each color signal, shift gates 3RO, 3GO, 3BO, 3RE, 3GE, 3BE, shift registers 4RO, 4GO, 4BO, 4RE, 4GE, 4BE, reset gates 5RO, 5GO, 5BO, 5RE, 5GE, 5BE, clamp circuits 6RO, 6GO, 6BO, 6RE, 6GE, 6BE, and amplifiers 7RO, 7GO, 7BO, 7RE, 7GE, 7BE are provided. The two-channel constitution for the photodiodes of odd numbers and even numbers may be adopted for the four photodiode arrays 2R, 2G, 2B, 2B/W.

[0185] Referring now to FIG. 23, there is shown a diagram of the photodiode arrays 2R, 2G, 2B, 2B/W. The photodiode arrays 2R, 2G, 2B, 2B/W may have respective widths 2330R, 2330G, 2330B, 2330B/W. For each photo-

diode array 2R, 2G, 2B, 2B/W, there maybe defined a respective center line 2310R, 2310G, 2310B, 2310B/W. The photodiode arrays 2R, 2G, 2B, 2B/W may be aligned in the main scanning direction 250, such that the center lines 2310R, 2310G, 2310B, 2310B/W are parallel to the main scanning direction 250.

[0186] The photodiode arrays 2R, 2G, 2B, 2B/W may be spaced at respective intervals 2361, 2362, 2363, and disposed in positions relative one another as shown. In the sub-scanning direction 260, the intervals between the center lines 2310R, 2310G, 2310B, 2310B/W may be an integral multiple of the reading pitch.

[0187] The photodiodes 2370R, 2370G, 2370B, 2370B/W have respective light receiving surfaces. The light receiving surfaces of the photodiodes 2370R, 2370G, 2370B, 2370B/W may have a uniform width 2350.

[0188] On the other hand, the light receiving surfaces of the photodiodes 2370R, 2370G, 2370B, 2370B/W may have different heights 2330R, 2330G, 2330B, 2330B/W. The height 2330R, 2330G, 2330B, 2330B/W may be set according to the sensitivity of the light receiving surface (light receiving part) of each photodiode. The sensitivity of the light receiving surface of each photodiode may be affected by many factors, including the transmission characteristic of a color filter (not shown in the drawing).

[0189] If the monochrome photodiode array 2B/W has no color filter, its sensitivity will generally be highest. Thus the height 2330B/W may be shortest. The height 2330R, 2330G, 2330B may be shortest in the order of green (G), red (R), and blue (B) which is the descending order of sensitivity (an example).

[0190] FIG. 24 is a timing chart showing the operation of the image sensor unit 2200. Further, the drawing shows a case that the number of pixels in the main scanning direction is 7500.

[0191] The gate control signals SH-R, SH-G, SH-B for the three primary colors R, G, and B which are given to the one-dimensional image sensor unit 2200 from the timing generation circuit 335 (FIG. 3) and the monochrome gate control signal SH-B/W are the same. As shown in FIG. 22, the clock signal for the shift registers 4RO, 4GO, 4BO, 4RE, 4GE, 4BE is common.

[0192] Therefore, in the color and monochrome modes, at the same timing, two-channel signals are output in parallel (B/W Output 1, B/W Output 2, R Output 1, R Output 2, G Output 1, G Output 2, B Output 1, B Output 2).

[0193] The operation of the processing system for a reading image signal after the analog processing unit 315 is almost the same for the seventh embodiment as in the first embodiment. The analog processing unit 315 and the A-D conversion circuit 320 respectively have a two-channel processing system for the color signals and the A-D conversion circuit 320 unifies the converted two-channel color signals to a one-channel color signal in consideration of the arrangement order shown in FIG. 25. The processes of the analog processing unit 315 and the A-D conversion circuit 320 for a monochrome signal are the same as those of the first embodiment.

[0194] The inter-line correction circuit 330, in consideration of differences in position between the color photodiode

arrays 2R, 2G, 2B and the monochrome photodiode array 2B/W in the sub-scanning direction 260, may convert and output an output signal from the shading correction unit 325 to a signal when the color lines and monochrome line coincide with each other in the sub-scanning direction 260. However, the number of lines of color output in the sub-scanning direction 260 from the image sensor unit 2200 coincides with that of monochrome output. Thus, unlike the first embodiment, the inter-line correction circuit 330 does not perform an interpolation process of doubling the number of lines (resolution) in the sub-scanning direction 260 for the color output.

[0195] In the seventh embodiment, at the stage of output from the inter-line correction circuit 330 (more retroactively, at the stage of output from the image sensor unit 2200), the numbers of color pixels and monochrome pixels in the main scanning direction and sub-scanning direction are equal to each other, so that the color signal correction unit 335 may be omitted.

[0196] Further, when the dynamic level (gradation) of the stored charge of each color photodiode is considerably lower than the dynamic level (gradation) of the stored charge of each monochrome photodiode, even if the light receiving area of each photodiode is changed by the light receiving component, the number of bits of a digital signal from the A-D conversion circuit 320 may be made different between the color photodiodes and the monochrome photodiodes. For example, the A-D conversion circuit 320 may convert color signals to four-bit digital signals and monochrome signals to eight-bit digital signals.

[0197] When the number of bits of a digital signal is different between color signals and monochrome signals like this, the color signal correction unit 335 may have a constitution as shown in FIG. 26. FIG. 27 is an illustration for the process of the color signal correction unit 2635 shown in FIG. 26. The color signal correction unit 2635 is a correction circuit for gradation instead of resolution and it executes a correction process of improving the gradation of a color signal using information of a monochrome signal.

[0198] The color signal correction unit 2635 has a CrCb calculation circuit 2630, an RGB resolution correction circuit 2631, and a parameter storage memory 2632.

[0199] Eight-bit monochrome pixel data $K(i, j)$ and four-bit color pixel data $R(i, j)$, $G(i, j)$, and $B(i, j)$ may be input to the color signal correction unit 2632 in a raster scan form.

[0200] The CrCb calculation circuit 2630, using the color input pixel data $R(i, j)$, $G(i, j)$, and $B(i, j)$ and the parameters a_{r0} , a_{g0} , a_{b0} , a_{r1} , a_{g1} , and a_{b1} stored in the parameter storage memory 2632, performs the YCrCb conversion indicated in Formulas (29) to (31) and obtains an eight-bit brightness signal (Y), a first color difference signal (Cr:R-Y component), and a second color difference signal (Cb:B-Y component).

$$Y(i, j) = K(i, j) \quad (29)$$

$$Cr(i, j) = a_{r0}R(i, j) + a_{g0}G(i, j) + a_{b0}B(i, j) \quad (30)$$

$$Cb(i, j) = a_{r1}R(i, j) + a_{g1}G(i, j) + a_{b1}B(i, j) \quad (31)$$

[0201] Further, the RGB resolution correction circuit 2631 executes the RGB reverse conversion meeting Formulas (32) to (34) using the parameters br_0 , br_1 , bb_0 , and bb_1

stored in the parameter storage memory **2632** and obtains eight-bit three primary colors R', G', and B' with the resolution thereof increased.

$$R'(i,j)=K(i,j)+b_{r0}Cr(i,j) \quad (32)$$

$$G'(i,j)=K(i,j)-b_{r1}Cr(k,j)+b_{b1}Cr(k,j) \quad (33)$$

$$B'(i,j)=K(i,j)+b_{b0}Cr(i,j) \quad (34)$$

[**0202**] The color signals may be converted to the brightness signal (Y=K), the first color difference signal (Cr), and the second color difference signal (Cb). Inversely, the brightness signal (Y=K), the first color difference signal (Cr), and the second color difference signal (Cb) may be converted to color signals.

[**0203**] The color signal correction unit **2635** may sequentially perform the YCrCb conversion and RGB reverse conversion, thereby converting the four-bit color signals to eight-bit signals.

[**0204**] By the image sensor unit **2200** of the seventh embodiment and the image reading apparatus adopting it, almost the same effects as those of the first embodiment can be obtained. Further, miniaturization and decrease in cost of the image sensor unit **2200** may be worse than the first embodiment. However, compared with a conventional three-line CCD unit, a sufficient effect can be expected. Further, since the light receiving area of each photodiode is decided in consideration of the sensitivity of each photodiode for each primary color signal, more improvement of the color image quality can be expected.

[**0205**] (H) Eighth Embodiment

[**0206**] The constitution of an image sensor unit of the eighth embodiment can be expressed by **FIG. 22** used for explanation of the seventh embodiment. The difference from the seventh embodiment is that the height of the light receiving surface of each color photodiode in the sub-scanning direction **260** is selected in consideration of not only the sensitivity of the light receiving surface (light receiving part) but also the respect indicated below.

[**0207**] In the eighth embodiment, with respect to the gate control signal from the timing generation circuit **335**, whenever the monochrome gate control signal SH-B/W is generated twice, the three primary color gate control signals SH-R, SH-G, SH-B are generated once. Namely, while monochrome signals are obtained in correspondence to two lines in the sub-scanning direction **260**, color signals are obtained in correspondence to two lines in the sub-scanning direction **260**. In consideration of the differences in the photoelectric conversion and charge storage time, the length of the light receiving surface of each color photodiode in the sub-scanning direction **260** is selected.

[**0208**] When the number of lines (resolution) in the sub-scanning direction **260** is different like this, a double density conversion by the inter-line correction circuit **330** in the sub-scanning direction **260** may be considered. However, in the eighth embodiment, the color signal correction unit **330** may perform a double density conversion in the sub-scanning direction **260**. The color signal correction unit **330** of the eighth embodiment may improve the resolution of color signals (three primary color signals) in the sub-scanning direction **260** using information of monochrome signals.

[**0209**] Referring now to **FIG. 28**, there is shown a block diagram of a color signal correction unit **2816** of the eighth

embodiment. **FIG. 29** is a schematic explanatory diagram of the process of the color signal correction unit **2816**. Monochrome signals and color signals represented by the same number of bits are input to the color signal correction unit **2816**.

[**0210**] In **FIG. 28**, the color signal correction unit **2816** has a CrCb calculation circuit **2830**, an RGB resolution correction circuit **2831**, a parameter storage memory **2832**, a delay line memory **2836**, and a data selector **2835**.

[**0211**] The inter-line correction circuit **2815** inputs the monochrome pixel data K(i, 2l-1) and K(i, 2l) in the relation shown in parts A and B of **FIG. 29** and the color pixel data R(i, l), G(i, l), and B(i, l) to the color signal correction unit **2816** in parallel. Further, a case that concurrent input of the monochrome pixel data K(i, 2l-1) and K(i, 2l) in correspondence to two lines is executed by the function of the delay line memory **2815A** in the inter-line correction circuit **2815** is shown in **FIG. 28**. However, the color signal correction unit **2816** may be provided with a line memory corresponding to it so as to obtain the monochrome pixel data K(i, 2l-1) and K(i, 2l) in correspondence to two lines.

[**0212**] The CrCb calculation circuit **2830**, using the color pixel data R(i, l), G(i, l), and B(i, l) and the parameters a_{r0} , a_{g0} , a_{b0} , a_{r1} , a_{g1} , and a_{b1} stored in the parameter storage memory **2832** performs the YCrCb conversion indicated in Formulas (35) to (38).

$$Y(i,2l-1)=K(i,2l-1) \quad (35)$$

$$Y(i,2l)=K(i,2l) \quad (36)$$

$$Cr(i,k)=a_{r0}R(i,l)+a_{g0}G(i,l)+a_{b0}B(i,l) \quad (37)$$

$$Cb(i,k)=a_{r1}R(i,l)+a_{g1}G(i,l)+a_{b1}B(i,l) \quad (38)$$

[**0213**] The RGB resolution correction circuit **2831** executes the RGB reverse conversion meeting Formulas (39) to (44) using the parameters b_{r0} , b_{r1} , b_{b0} , and b_{b1} stored in the parameter storage memory **2832** and obtains three primary colors R', G', B' with the resolution (the number of pixels) in the sub-scanning direction **260** increased.

$$R'(i,2l-1)=K(i,2l-1)+b_{r0}Cr(i,l) \quad (39)$$

$$G'(i,2l-1)=K(i,2l-1)-b_{r1}Cr(i,l)+b_{b1}Cr(i,l) \quad (40)$$

$$B'(i,2l-1)=K(i,2l-1)+b_{b0}Cr(i,l) \quad (41)$$

$$R'(i,2l)=K(i,2l)+b_{r0}Cr(i,l) \quad (42)$$

$$G'(i,2l)=K(i,2l)-b_{r1}Cr(i,l)+b_{b1}Cr(i,l) \quad (43)$$

$$B'(i,2l)=K(i,2l)+b_{b0}Cr(i,l) \quad (44)$$

[**0214**] In the eighth embodiment, the number of pixels of the brightness signal Y in the main scanning direction **250** is twice the number of pixels of the first color difference signal Cr and the second color difference signal Cb in the main scanning direction **250**. Thus, the number of pixels of the color signals R', G', B' in the sub-scanning direction **260** after conversion may be set to the same number of pixels as that of the brightness signal Y before conversion.

[**0215**] Formulas (39) to (41) are calculation expressions of data at the pixel positions on the odd lines of the three-primary color signals R', G', B' after conversion. Formulas (42) to (44) are calculation expressions of data at the pixel positions on the even lines of the color signals R', G', B' after conversion.

[**0216**] The RGB resolution correction circuit **2831** may give the obtained color signals R'(i, 2l-1), G'(i, 2l-1), B'(i, 2l-1) at the pixel positions on the odd lines to the data

selector **2835** as a first selection input. The line memory **2836** may delay the color signals $R'(i, 2l)$, $G'(i, 2l)$, $B'(i, 2l)$ at the pixel positions on the even lines by one pixel period, and then may give the signals to the data selector **2835** as a second selection input. **FIG. 28** shows a case that even in the color mode, the brightness signal, that is, the monochrome signals $K(i, 2l-1)$ and $K(i, 2l)$ are output from the color signal correction unit **2816**.

[0217] The data selector **2835**, according to a discrimination signal **2840** (indicated as Odd/Even line discrimination signal in **FIG. 28**) on the odd or even sub-scanning lines from the timing generation circuit **335**, selects and outputs $R'(i, 2l-1)$, $G'(i, 2l-1)$, $B'(i, 2l-1)$ on the odd lines and $R'(i, 2l)$, $G'(i, 2l)$, $B'(i, 2l)$ on the even lines.

[0218] By the image sensor unit of the eighth embodiment and the image reading apparatus adopting it, almost the same effects as those of the first embodiment can be obtained.

[0219] (I) Ninth Embodiment

[0220] Referring now to **FIG. 30**, there is shown a block diagram showing the constitution of an image sensor unit **3000** of a ninth embodiment and to the same and corresponding parts as those shown in **FIG. 4** relating to the first embodiment, the same and corresponding numerals are assigned. The position of the image sensor unit **3000** to the whole image reading apparatus is the position shown in **FIG. 3** in the same way as with the image sensor unit **400** of the first embodiment.

[0221] In the image sensor unit **3000**, the number of photodiodes (the number of pixels) of the color photodiode arrays **2R**, **2G**, **2B** in the main scanning direction **250** is $\frac{2}{3}$ of the number of photodiodes (the number of pixels) of the monochrome photodiode array **2B/W** in the main scanning direction **250**. Thus, the length of the light receiving surface of each color photodiode in the main scanning direction **250** is $\frac{2}{3}$ of the length of the light receiving surface of each monochrome photodiode in the main scanning direction **250**. For example, the ninth embodiment can be applied to an image reading apparatus having 5000 color pixels (400 dpi) and 7500 monochrome pixels (600 dpi) in the main scanning direction **250**.

[0222] According to the difference in the length of the light receiving surface in the main scanning direction **250** between the color photodiodes and the monochrome photodiodes, also in the sub-scanning direction **260**, the length of the light receiving surface of the color photodiodes is longer than the length of the light receiving surface of the monochrome photodiodes.

[0223] Further, the output constitution of stored charges of the photodiode arrays is the same both in the colors and monochrome. Namely, as to each color signal and a monochrome signal, the shift gates **3R**, **3G**, **3B**, **3B/W**, shift registers **4R**, **4G**, **4B**, **4B/W**, reset gates **5R**, **5G**, **5B**, **5B/W**, clamp circuits **6R**, **6G**, **6B**, **6B/W**, and amplifiers **7R**, **7G**, **7B**, **7B/W** may be installed for each channel.

[0224] Referring now to **FIG. 31**, there is shown a timing chart showing the operation of the image sensor unit **3000** of the ninth embodiment. The gate control signals SH-R, SH-G, SH-B for the three primary colors R, G, B which are given to the image sensor unit **3000** from the timing generation circuit **355** (refer to **FIG. 3**) and the monochrome

gate control signal SH-B/W may be the same. As shown in **FIG. 31**, the clock signal for the shift registers **4RO**, **4GO**, **4BO**, **4RE**, **4GE**, **4BE** may be common. Namely, although the resolution (the number of pixels, the number of photodiodes) in the main scanning direction **250** is different between the color photodiode arrays and the monochrome photodiode array, they are driven at the same time.

[0225] By adjusting the control signals given to the reset gates **5R**, **5G**, **5B**, **5B/W** and the clamp circuits **6R**, **6G**, **6B**, **6B/W**, the effective pixel areas can be made different between the three primary colors R, G, B and the monochrome. This allows the desired resolution to be selected.

[0226] In an image reading apparatus of the ninth embodiment, the operation of the processing system for a reading image signal after the analog processing unit **315** is almost the same as that of the first embodiment.

[0227] The inter-line correction circuit **330**, in consideration of differences in position between the color photodiode arrays and the monochrome photodiode array in the sub-scanning direction **260**, converts and outputs an output signal from the shading correction unit **325** to a signal when the three primary colors R, G, B lines and monochrome line coincide with each other in the sub-scanning direction **260**. However, the number of lines of color output in the sub-scanning direction **260** from the image sensor unit **3000** coincides with that of monochrome output. Thus, unlike the first embodiment, the inter-line correction circuit **330** does not perform an interpolation process of doubling the number of lines (resolution) in the sub-scanning direction **260** for the color output.

[0228] The color signal correction unit **335**, in the main scanning direction **250**, improves the resolution of signals of the three primary colors R, G, B using information of a monochrome signal. Also in this case, the color signal correction unit **335** sequentially performs the YCrCb conversion and RGB reverse conversion so as to improve the resolution. However, since the section of three monochrome pixels coincides with the section of two color pixels, the color signal correction unit **335** performs the RGB reverse conversion in consideration of it.

[0229] For example, in a case of Y(K), Cr, and Cb as shown in Part A of **FIG. 32**, the three primary colors **R1**, **G1**, **B1** at the pixel position **K1** may be obtained by reverse conversion of **K1**, **Cr1**, **Cb1**. The three primary colors **R2**, **G2**, **B2** at the pixel position **K2** may be obtained by the reverse conversion for **K2**, $(Cr1+Cr2)/2$, and $(Cb1+Cb2)/2$. The three primary colors **R1**, **G1**, **B1** at the pixel position **K3** may be obtained by the reverse conversion for **K3**, **Cr3**, **Cb3**.

[0230] By the image sensor unit **3000** of the ninth embodiment and the image reading apparatus adopting it, almost the same effects as those of the first embodiment can be obtained.

[0231] (J) Other Embodiments

[0232] In the image reading apparatuses of the aforementioned embodiments, in both color mode for reading color documents and monochrome mode for reading monochrome documents, the moving speeds in the sub-scanning direction are the same. However, even in a case of different speeds, the present invention can be applied. Namely, the sensor unit of the present invention can be incorporated into an image

reading apparatus that the moving speed in the sub-scanning direction is different between the color mode and the monochrome mode.

[0233] Further, in the embodiments mentioned above, the image sensor unit has a monochrome photodiode array. However, also to an image sensor unit having no monochrome photodiode array, the technical thought of the present invention can be applied. For example, the light receiving area of each photodiode for the three primary colors R, G, B may be changed with the sensitivity.

[0234] Furthermore, in the above explanation, the image sensor unit is composed of one chip. However, it may be composed of a plurality of chips.

[0235] Furthermore, in the embodiments mentioned above, also in the color mode, monochrome signals may be output. However, in the color mode, the image sensor unit may output only signals of the three primary colors R, G, B.

[0236] Further, in the above explanation, the color signal correction unit performs the resolution conversion only in one of the main scanning direction and sub-scanning direction using information of monochrome signals. However, it may perform the resolution conversion in both the main scanning direction and sub-scanning direction. For example, like the first embodiment, when the light receiving surface of each color photodiode is two times of that of each monochrome photodiode in the main scanning direction and sub-scanning direction, a method for firstly doubling the density using information of a monochrome signal in the sub-scanning direction and then doubling the density using information of a monochrome signal in the main scanning direction may be used.

[0237] Furthermore, information of a monochrome signal required by the color signal correction unit may be obtained by a reading operation different from the reading operation for obtaining a color signal. In other words, by double reading of a document, a monochrome signal and a color signal may be obtained separately.

[0238] Furthermore, in the above explanation, the color signal correction unit sequentially performs the YCrCb conversion and RGB reverse conversion. However, a method for arranging the YCrCb conversion formula and RGB reverse conversion formula, obtaining a formula for unifying and executing the YCrCb conversion and RGB reverse conversion, and unifying and executing the YCrCb conversion and RGB reverse conversion according to the formula may be adopted. Further, the color signal correction unit may be composed of hardware or software.

[0239] Further, the light receiving elements for photoelectric conversion are not limited to photodiodes and may be other photoelectric conversion elements. The shift registers are not limited to those having the CCD constitution.

[0240] Furthermore, the image sensor units of the embodiments mentioned above output three-primary color signals (R, G, B) as a color signal. However, also to an image sensor unit for outputting a combination of other color components such as yellow, cyan, and magenta, the present invention can be applied.

[0241] As mentioned above, according to the present invention, an image sensor unit and an image reading apparatus can be realized that the evaluation can be

improved in more items than conventional such as the size and cost of the image sensor unit, monochrome image quality, color image quality, speed in the sub-scanning direction in the color mode, and through-pass read characteristic.

[0242] Although exemplary embodiments of the present invention have been shown and described, it will be apparent to those having ordinary skill in the art that a number of changes, modifications, or alterations to the invention as described herein may be made, none of which depart from the spirit of the present invention. All such changes, modifications and alterations should therefore be seen as within the scope of the present invention.

It is claimed:

1. An image sensor unit comprising

a first photoconverter comprising a first array of first light receiving elements, the first photoconverter for photoelectrically converting light of a first light quality from a source image for outputting first signals by photoelectric conversion, the first signals having a first image quality

a second photoconverter comprising a second array of second light receiving elements, the second photoconverter for photoelectrically converting light of a second light quality from the source image for outputting second signals by photoelectric conversion, the second signals having a second image quality, wherein the second image quality is better than the first image quality

a signal correction unit to

produce first enhanced signals corresponding to the first light quality from the source image

use the second signals to modify the first signals to produce the first enhanced signals.

2. The image sensor unit of claim 1 wherein

the first photoconverter is a color photoconverter

the second photoconverter is a monochrome photoconverter.

3. The image sensor unit of claim 1 wherein

the first light quality comprises a first color

the second light quality comprises black and white

the image sensor comprises a third photoconverter comprising a third array of third light receiving elements, the third photoconverter for photoelectrically converting light of a third light quality from the source image for outputting third signals by photoelectric conversion, the third light quality comprising a second color different from the first color

the image sensor comprises a fourth photoconverter comprising a fourth array of fourth light receiving elements, the fourth photoconverter for photoelectrically converting light of a fourth light quality from the source image for outputting fourth signals by photoelectric conversion, the fourth light quality comprising a third color different from the first color and the second color

the signal correction unit further to

- produce second enhanced signals corresponding to the third light quality from the source image
- produce third enhanced signals corresponding to the fourth light quality from the source image
- use the second signals to modify the third signals to produce the second enhanced signals
- use the second signals to modify the fourth signals to produce the third enhanced signals.

4. An image reading apparatus including the image sensor unit of claim 3 and further having a color mode, wherein the image sensor outputs color signals and monochrome signals.

5. The image reading apparatus of claim 4 wherein the signal correction unit is further for improving the color signals' gradation.

6. The image reading apparatus of claim 4 wherein the color signals are signals of three primary colors and the signal correction unit is for converting the three primary color signals and the monochrome signals to data indicating color characteristics.

7. A process for producing image signals comprising

- providing a first photoconverter comprising a first array of first light receiving elements
- providing a second photoconverter comprising a second array of second light receiving elements
- the first photoconverter photoelectrically converting light of a first light quality from a source image
- the second photoconverter photoelectrically converting light of a second light quality from the source image
- outputting first signals from the first photoconverter having a first quality of a characteristic
- outputting second signals from the second photoconverter having a second quality of the characteristics better than the first quality
- enhancing the first quality using the second signals.

8. The process for producing image signals of claim 7 wherein

- the first photoconverter is a color photoconverter
- the second photoconverter is a monochrome photoconverter.

9. The process for producing image signals of claim 7 wherein the first light quality comprises a first color and the second light quality comprises black and white, the process further comprising

- providing a third photoconverter comprising a third array of third light receiving elements
- providing a fourth photoconverter comprising a fourth array of fourth light receiving elements
- the third photoconverter photoelectrically converting light of a third light quality from the source image, the third light quality comprising a second color different from the first color
- the fourth photoconverter photoelectrically converting light of a fourth light quality from the source image, the fourth light quality comprising a third color different from the first color and the second color

- outputting third signals from the third photoconverter having a third quality of the characteristic
- outputting fourth signals from the fourth photoconverter having a fourth quality of the characteristic
- enhancing the third quality using the second signals
- enhancing the fourth quality using the second signals.

10. The process for producing image signals of claim 7, wherein the first signals are color signals and the second signals are monochrome signals.

11. The process for producing image signals of claim 9 wherein the characteristic comprises resolution.

12. The process for producing image signals of claim 9 wherein the characteristics comprises gradation.

13. A process for producing image signals comprising

- receiving a first color image signal for a first color
- receiving a second color image signal for a second color
- receiving a third color image signal for a third color
- receiving monochrome image signals for black and white
- improving a quality of at least one of the first, second and third color signals using information in the monochrome signals.

14. The process for producing image signals of claim 13 wherein the first color is red, the second color is green and the third color is blue.

15. The process for producing image signals of claim 13 comprising improving the quality by

- obtaining brightness signals from the monochrome image signals
- obtaining a first color difference signal from the first, second and third color image signals
- obtaining a second color difference signal from the first, second and third color image signals
- obtaining enhanced first color image signals from the brightness signals and the first color difference signals
- obtaining enhanced second color image signals from the brightness signals, the first color difference signals and the second color difference signals
- obtaining enhanced third color image signals from the brightness signals and the first color difference signals.

16. The process for producing image signals of claim 13 wherein the enhanced first, second and third color image signals have improved resolution over the first, second and third color image signals.

17. The process for producing image signals of claim 13 wherein the enhanced first, second and third color image signals have improved gradation over the first, second and third color image signals.

18. A color signal processing circuit for processing plural channels of input color signals using input monochrome signals, wherein the channels of input color signals represent respective numbers of respective color pixels and the input monochrome signals represent a number of monochrome pixels, wherein the number of monochrome pixels is larger than the number of color pixels of at least one of the channels of input color signals, the color signal processing circuit comprising

a first circuit to produce brightness signals, first color difference signals and second color difference signals from the input color signals and the input monochrome signals

a second circuit to use the brightness signal, the first color difference signal and the second color difference signal to obtain output color signals corresponding to at least one of the channels, wherein the output color signals represent a number of pixels greater than the number of pixels in the corresponding channel of input color signals.

19. The color signal processing circuit of claim 18 wherein

the numbers are counted in a first dimension

the input color signals and the input monochrome signals represent a same number of pixels in a second dimension.

20. The color signal processing circuit of claim 18 wherein the numbers are counted in two dimensions.

21. The color signal processing circuit of claim 18 wherein the first circuit is to produce the first color differ-

ence signals and the second color difference signals from the input color signals and without the input monochrome signals.

22. The color signal processing circuit of claim 18 wherein there are three channels of input color signals representing three primary colors.

23. The color signal processing circuit of claim 22 wherein

the channels of input color signals represent different numbers of pixels

the different numbers less than the second number.

24. The color signal processing circuit of claim 22 wherein

the channels of input color signals represent a same numbers of pixels

the second circuit is to obtain output color signals of the three channels.

25. An image reading apparatus comprising the color signal processing circuit of claim 18.

* * * * *