

(19) World Intellectual Property Organization
International Bureau



(43) International Publication Date
19 August 2010 (19.08.2010)

PCT

(10) International Publication Number
WO 2010/093592 A1

(51) International Patent Classification:
H01L 51/00 (2006.01) C09D 11/00 (2006.01)
B41J 2/21 (2006.01)

Nagano-ken, 392-8502 (JP). SEKI, Shunichi [JP/JP];
3-3-5, Owa, Suwa-shi, Nagano-ken, 392-8502 (JP).

(21) International Application Number:
PCT/US2010/023540

(74) Agents: SINDER, Stuart et al.; Kenyon & Kenyon LLP,
One Broadway, New York, NY 10004 (US).

(22) International Filing Date:
9 February 2010 (09.02.2010)

(81) Designated States (unless otherwise indicated, for every
kind of national protection available): AE, AG, AL, AM,
AO, AT, AU, AZ, BA, BB, BG, BH, BR, BW, BY, BZ,
CA, CH, CL, CN, CO, CR, CU, CZ, DE, DK, DM, DO,
DZ, EC, EE, EG, ES, FI, GB, GD, GE, GH, GM, GT,
HN, HR, HU, ID, IL, IN, IS, JP, KE, KG, KM, KN, KP,
KR, KZ, LA, LC, LK, LR, LS, LT, LU, LY, MA, MD,
ME, MG, MK, MN, MW, MX, MY, MZ, NA, NG, NI,
NO, NZ, OM, PE, PG, PH, PL, PT, RO, RS, RU, SC, SD,
SE, SG, SK, SL, SM, ST, SV, SY, TH, TJ, TM, TN, TR,
TT, TZ, UA, UG, US, UZ, VC, VN, ZA, ZM, ZW.

(25) Filing Language: English

(26) Publication Language: English

(30) Priority Data:
12/369,525 11 February 2009 (11.02.2009) US

(71) Applicants (for all designated States except US): UNI-
VERSAL DISPLAY CORPORATION [US/US]; 375
Philips Boulevard, Ewing, NJ 08618 (US). SEIKO EP-
SON CORPORATION [JP/JP]; 4-1, Nishishinjyuku 2-
Chome, Shinjyuku-ku, 163 Tokyo (JP).

(84) Designated States (unless otherwise indicated, for every
kind of regional protection available): ARIPO (BW, GH,
GM, KE, LS, MW, MZ, NA, SD, SL, SZ, TZ, UG, ZM,
ZW), Eurasian (AM, AZ, BY, KG, KZ, MD, RU, TJ,
TM), European (AT, BE, BG, CH, CY, CZ, DE, DK, EE,
ES, FI, FR, GB, GR, HR, HU, IE, IS, IT, LT, LU, LV,
MC, MK, MT, NL, NO, PL, PT, RO, SE, SI, SK, SM,
TR), OAPI (BF, BJ, CF, CG, CI, CM, GA, GN, GQ, GW,
ML, MR, NE, SN, TD, TG).

(72) Inventors; and

(75) Inventors/Applicants (for US only): CHEON, Kwong-
Ohk [KR/US]; 15 Old Mill Lane, Holland, PA 18966
(US). XIA, Chuanjun [CN/US]; 16 Cliveden Court,
Lawrenceville, NJ 08648 (US). INBASEKARAN,
Michael [US/US]; 252 Holcombe Way, Lambertville, NJ
08530 (US). SONOYAMA, Takuya [JP/JP]; 3-3-5, Owa,
Suwa-shi, Nagano-ken, 392-8502 (JP). ITO, Masaki [JP/
JP]; 3-3-5, Owa, Suwa-shi, Nagano-ken, 392-8502 (JP).
UCHIDA, Masahiro [JP/JP]; 3-3-5, Owa, Suwa-shi,

Published:

— with international search report (Art. 21(3))

(54) Title: LIQUID COMPOSITIONS FOR INKJET PRINTING OF ORGANIC LAYERS OR OTHER USES

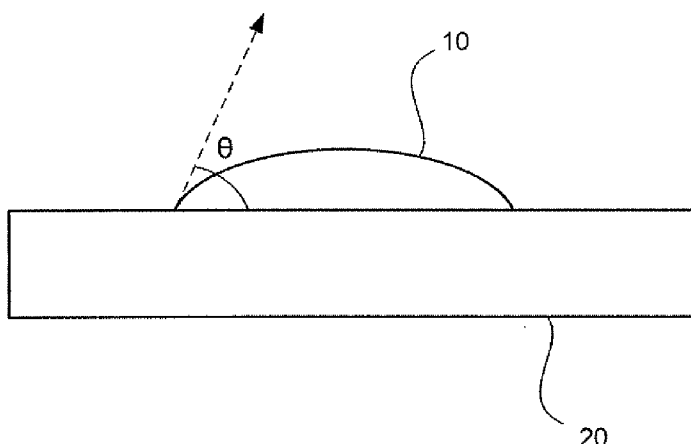

FIG. 1

(57) Abstract: A method of forming an organic layer by using a liquid composition comprising a small molecule organic semiconductor material mixed in a ketone solvent. The liquid composition is deposited on a surface to form the organic layer. The ketone solvent may be an aromatic ketone solvent, such as a tetralone solvent. The organic semiconductor material may be cross-linkable to provide a cross-linked organic layer. The method can be used to make organic electronic devices, such as organic light emitting devices. In another aspect, the liquid composition comprises a small molecule organic semiconductor material mixed in an aromatic ether solvent. Also, provided are liquid compositions which can be used to make organic layers. The melting point of the aromatic ketone solvent or the aromatic ether solvent is 25° C or lower. One claim is directed to a wetting contact angle of the ketone solvent of 20° or less.



WO 2010/093592 A1

LIQUID COMPOSITIONS FOR INKJET PRINTING OF ORGANIC LAYERS OR OTHER USES

TECHNICAL FIELD

[0001] The present invention relates to methods for making organic layers in organic electronic devices, such as organic light emitting devices.

BACKGROUND

[0002] Traditionally, organic light emitting devices (OLEDs) have been fabricated by vacuum deposition for small molecule materials, and by spin-coating or dip coating for polymeric materials. More recently, inkjet printing has been used to directly deposit organic thin film layers in the fabrication of OLEDs. For inkjet printing of polymeric materials, a variety of conventional solvents can be used, such as toluene or xylene. However, these solvents conventionally used for inkjet printing of polymeric materials often do not work as well for the deposition of small molecule materials. Thus, there is a need for an improved inkjet fluid formulation suitable for the inkjet printing of small molecule materials to form organic layers.

SUMMARY

[0003] In one aspect, the present invention provides a method for forming an organic layer comprising: providing a liquid composition comprising a small molecule organic semiconductor material mixed in an aromatic ketone solvent having a melting point of 25° C or lower; and depositing the liquid composition on a surface. The method may be used for making an organic electronic device.

[0004] In another aspect, the present invention provides a liquid composition comprising: an aromatic ketone solvent having a melting point of 25° C or lower; and a small molecule organic semiconductor material mixed in the aromatic ketone solvent at a concentration in the range of 0.01 – 10 wt%.

[0005] In another aspect, the present invention provides a method for forming an organic layer comprising: providing a liquid composition comprising a small molecule organic semiconductor material mixed in an aromatic ether solvent having a melting point of 25° C or

lower; and depositing the liquid composition on a surface. The method may be used for making an organic electronic device.

[0006] In another aspect, the present invention provides a liquid composition comprising: an aromatic ether solvent having a melting point of 25° C or less; and a small molecule organic semiconductor material mixed in the aromatic ether solvent at a concentration in the range of 0.01 – 10 wt%.

BRIEF DESCRIPTION OF THE DRAWINGS

[0007] FIG. 1 shows a droplet of a ketone solvent of the present invention applied onto a planar, untreated surface made of indium tin oxide with the wetting contact angle θ being measured.

[0008] FIG. 2 shows the structure of an OLED according to an embodiment of the present invention.

[0009] FIGS. 3A (top view) and 3B (cross-section side view) show a schematic illustration of a substrate onto which inkjet printing may be applied.

[0010] FIGS. 4A-4C shows the results from the inkjet printing of a small molecule organic semiconductor material using various organic solvents.

[0011] FIG. 5 shows the lifetime (plotted as luminance v. time) of an OLED made according to an embodiment of the present invention.

DETAILED DESCRIPTION

[0012] The meaning of the following terms, as intended to be used herein, are as follows:

[0013] The term “aliphatic” means a saturated or unsaturated hydrocarbyl in a linear, branched, or non-aromatic ring. The carbons can be joined by single bonds (alkyls), double bonds (alkenyls), or triple bonds (alkynyls). Besides hydrogen, other elements such as oxygen, nitrogen, sulfur, or halogens can be bound to the carbons as substitutions. The term “aliphatic” also encompasses hydrocarbyls containing heteroatoms, such as oxygen, nitrogen, sulfur, phosphorus, and silicon in place of carbon atoms.

[0014] The term “alkyl” means alkyl moieties and encompasses both straight and branched alkyl chains. Additionally, the alkyl moieties themselves may be substituted with one or more substituents. The term “heteroalkyl” means alkyl moieties that include heteroatoms.

[0015] The term “lower,” when referring to an aliphatic or any of the above-mentioned types of aliphatics, means that the aliphatic group contains from 1 – 15 carbon atoms. For example, lower alkyl groups include methyl, ethyl, propyl, isopropyl, butyl, isobutyl, *tert*-butyl, and the like.

[0016] The term “aryl” means a hydrocarbyl containing at least one aromatic ring, including single-ring groups and polycyclic ring systems. The term “heteroaryl” means a hydrocarbyl containing at least one heteroaromatic ring (i.e., containing heteroatoms), including single-ring groups and polycyclic ring systems. The polycyclic rings may have two or more rings in which two carbon atoms are common by two adjoining rings (i.e., the rings are “fused”), wherein at least one of the rings is aromatic or heteroaromatic. The term “lower aryl” or “lower heteroaryl” means an aryl or heteroaryl, respectively, containing from 3 – 15 carbon atoms.

[0017] Examples of aryl groups include benzene, naphthalene, anthracene, phenanthrene, perylene, tetracene, pyrene, benzopyrene, chrysene, triphenylene, acenaphthene, fluorene, and those derived therefrom. Examples of heteroaryl groups include furan, benzofuran, thiophen, benzothiophen, pyrrole, pyrazole, triazole, imidazole, oxadiazole, oxazole, thiazole, tetrazole, indole, carbazole, pyrroloimidazole, pyrrolopyrazole, pyrrolopyrrole, thienopyrrole, thienothiophen, furopyrrole, furofuran, thienofuran, benzoisoxazole, benzoisothiazole, benzoimidazole, pyridine, pyrazine, pyridazine, pyrimidine, triazine, quinoline, isoquinoline, cinnoline, quinoxaline, phenanthridine, benzoimidazole, perimidine, quinazoline, quinazolinone, azulene, and those derived therefrom.

[0018] The present invention relates to the forming of organic layers by solution processing techniques. In one aspect, the present invention provides a method of forming an organic layer. The method comprises providing a liquid composition comprising a small molecule organic semiconductor material mixed in a ketone solvent. The liquid composition is then deposited on a surface and dried to form the organic layer.

[0019] By “ketone solvent,” we mean that the solvent compound has one or more ketone functional groups in the molecular structure. In certain embodiments, the ketone solvent is an aromatic ketone solvent. By “aromatic ketone solvent,” we mean that the solvent molecule includes one or more aryl or heteroaryl groups and one or more ketone functional groups.

[0020] In certain embodiments, the aromatic ketone solvent is a tetralone solvent. By “tetralone solvent,” we mean that the solvent compound is or contains a bicyclic ketone in which

a phenyl ring is fused with a cyclohexanone. Examples of tetralones that can be used in the present invention include 1-tetralone and 2-tetralone shown below. The chemical and/or physical properties of 1-tetralone and 2-tetralone are known in the art or can be readily determined by conventional techniques. For example, 1-tetralone is known to have a boiling point of 256° C (at 1 atm), density of 1.1 g/cm³ (at 20° C), melting point of 5-6° C (at 1 atm), and molecular weight of 146.

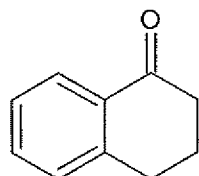

1-tetralone

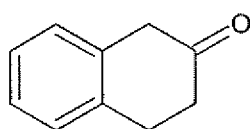

2-tetralone

[0021] The term “tetralone solvent” is also intended to encompass derivatives of 1-tetralone and 2-tetralone in which there are one or more substitutions on either or both of the rings (i.e., the phenyl and cyclohexane rings). Such substitutions include lower aliphatic, lower aryl, lower heteroaryl, or halogen. As such, other examples of tetralone solvents that can be used in the present invention include 2-(phenylepoxy)tetralone and 6-(methoxy)tetralone

[0022] Other examples of aromatic ketone solvents that can be used in the present invention include acetophenone (methyl phenyl ketone), propiophenone (ethyl phenyl ketone), benzophenone (diphenyl ketone), and their derivatives, such as 4-methylpropiophenone.

Table 1.

	 acetophenone	 propiophenone	 Benzophenone
Boiling point (at 1 atm)	202° C	218° C	305° C
Density (at 20° C)	1.03 g/cm ³	1.01 g/cm ³	1.11 g/cm ³

Melting point (at 1 atm)	19-20° C	19° C	48° C
Molecular weight	120	134	182

[0023] Other ketone solvents that may be used in the present invention do not have an aryl or heteroaryl group. One such example of a ketone solvent is isophorone as shown below, which has a boiling point of 215° C (at 1 atm), density of 0.92 g/cm³ (at 20° C), melting point of -8° C (at 1 atm), and a molecular weight of 138.

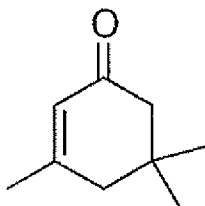

[0024] In some cases, the ketone solvent may be a blend of two or more ketone solvents. One such example of a blended ketone solvent is EASTMAN C-11 KETONE™ (Eastman), which has a boiling point of 200° C at 1 atm, melting point of -12° C, and density of 0.84 mg/cm³. In some cases, the liquid composition itself may use a blend of solvents, including solvents that are not ketones solvents of the present invention. In such cases, the ketone solvent(s) constitutes at least 50% (by volume) of the solvent volume in the liquid composition.

[0025] The ketone solvents used in the present invention may have various chemical/physical properties that make it useful for forming organic layers by solution processing techniques, such as inkjet printing. For example, the ketone solvent may have a melting point of 25° C or below. In some cases, the ketone solvent has a molecular weight in the range of 100 – 250. In some cases, the ketone solvent has a boiling point of 150° C or greater, or 200° C or greater; and in some cases, a boiling point in the range of 150° C – 350° C or 200° C – 350°. Boiling points in this range may be useful in preventing nozzle clogging of the inkjet print head.

[0026] The organic semiconductor material is a small molecule organic compound (including organometallic compounds) which is capable of exhibiting semiconducting properties, i.e., in

which the energy gap between conduction and valence bands is in the range of 0.1 – 4 eV. The small molecule organic semiconductor material may be any of those known or proposed to be used in the fabrication of organic electronic devices, such as organic light emitting devices. For example, the organic semiconductor material may be a charge transport compound (hole or electron transporting) or an emissive phosphorescent compound.

[0027] The term “small molecule” refers to any compound that is not a polymer, and “small molecules” may actually be quite large. Small molecules may include repeat units in some circumstances. For example, using a long chain alkyl group as a substituent does not exclude the molecule from being a “small molecule.” In general, a small molecule has a well-defined chemical formula with a single molecular weight, whereas a polymer has a chemical formula and a molecular weight that may vary from molecule to molecule. The molecular weight of the small molecule organic semiconductor material is typically 3,000 or less.

[0028] In certain embodiments, the organic semiconductor material is a charge transport compound. Various types of charge transport compounds are known in the art, including triaryl amines, phthalocyanines, metal phthalocyanines, porphyrins, metal porphyrins, indolocarbazoles, metal complexes, iminostilbene-containing compounds, and carbazole-containing compounds.

[0029] In certain embodiments, the organic semiconductor material has one or more cross-linking functional groups, which allows for the formation of a covalent bond with a reactive group on another molecule (such as another organic semiconductor material having a cross-linking functional group). For example, various types of charge transport compounds having cross-linking functional groups are known in the art. In some cases, the charge transport compound may be an organometallic complex having cross-linking functional groups, such as the cross-linkable iridium-ligand complexes described in U.S. Appln. Publication No. 2008/0220265 (Sept. 11, 2008) to Xia et al., which is incorporated by reference herein in its entirety. Such, cross-linkable iridium complexes include those having the general structure:

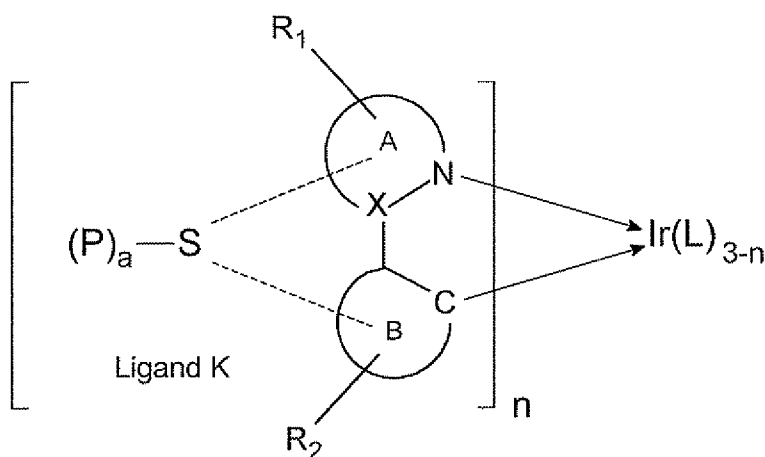

[0030] Each L represents a ligand that coordinates with the iridium, including any of various bidentate ligands which contain delocalized π -electrons, or which serve to improve the solubility (aqueous or organic), mesogenic property, or charge transport capability of the iridium complex. For example, the ligand L may be a phenylpyridine or acetylacetone.

[0031] Each K also represents a ligand, which comprises a structure R_1 —A—B— R_2 , spacer group S, and one or more cross-linkable functional groups P. The variable “n” has an integer value ranging from 1 to 3. Where $n=1$, the ligands L may be same or different from each other. Where $n=2$ or $n=3$, each of the ligands K may be same or different from each other. Example of cross-linkable functional groups P include vinyl, acrylate, epoxide, oxetane, trifluoroethylene, benzocyclobutene, siloxane, maleimide, cyanate ester, ethynyl, nadimide, phenylethynyl, biphenylene, phthalonitrile, or boronic acid.

[0032] The structure A—B represents a pair of aromatic rings that are bonded to each other. Rings A and B are each a 5 or 6-membered ring. Atom X on ring A represents a heteroatom, which may be nitrogen or carbon. The structure A—B is coordinated to the iridium via a nitrogen atom on ring A and an sp^2 hybridized carbon on ring B.

[0033] Each of rings A or B may optionally be substituted by substitution groups R_1 and R_2 , wherein each of R_1 and R_2 represents one or more independently selected substitutions located at any position on their respective rings. R_1 or R_2 may be linked or fused to their respective rings. The R_1 and R_2 substitution groups can include lower aliphatic, lower aryl, or lower heteroaryl groups.

[0034] More examples of charge transport compounds having cross-linkable reactive functional groups include those disclosed in U.S. Application Publication No. 2004/0175638 to Tierney et al. (published 9 Sept. 2004), which is incorporated by reference herein. Other

examples include the polymerizable triarylamine-containing perfluorocyclobutanes (PFCBs) disclosed in X. Jiang et al., *Advanced Functional Materials*, vol. 12:11-12, pp. 745-751 (December 2002). Other examples include the polynorbornenes with pendant triarylamine (TPA) groups described in E. Bellman et al., *Chem. Mater.*, vol. 10:1668-1676 (1998). Other examples include the cross-linkable N,N'-bis-(m-tolyl)-N,N'-diphenyl-1,1'-biphenyl-4,4'-diamine (TPD)-based hole transport polymers described in B. Domercq et al., *Chem. Mater.*, vol. 15:1491-1496 (2003). Other examples include the triarylamine-based hole transport molecules and polymers with pendant oxetane groups described in O. Nuyken et al., *Designed Monomers & Polymers*, vol. 5:2-3, pp. 195-210 (2002). Other examples include the cross-linkable or chain-extendable polyarylpolyamines described in U.S. Patent No. 5,929,194 to Woo et al. (issued 27 July 1999), which is incorporated by reference herein in its entirety.

[0035] Other examples include the hexa-alkoxytriphenylenes having acrylate groups described in A. Bacher et al., *Macromolecules*, vol. 32:4551-4557 (1999). Other examples include the cross-linkable hole-conducting polymers described in E. Bacher et al., *Macromolecules*, vol. 38:1640-1647 (2005). Other examples include the reactive benzodithiophenes described in U.S. Patent No. 6,913,710 to Farrand et al. (issued 5 July 2005), which is incorporated by reference herein in its entirety. Other examples of charge transport compounds having cross-linking groups are described in Muller et al., *Synthetic Metals* 111/112:31-34 (2000) and U.S. Appl. Publication No. 2005/0158523 (Gupta et al.), which are incorporated by reference herein. Other examples of charge transport compounds having cross-linkable reactive groups include styryl group-bearing arylamine derivatives such as N⁴,N^{4'}-di(naphthalen-1-yl)-N⁴,N^{4'}-bis(4-vinylphenyl)biphenyl-4,4'-diamine:

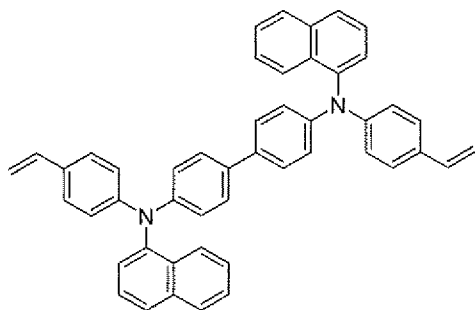

[0036] The concentration of the organic semiconductor material in the liquid composition will vary according to the particular application. In certain embodiments, the organic semiconductor material is provided at a concentration that is suitable for inkjet printing. In some

cases, the concentration of the organic semiconductor material is in the range of 0.01 – 10 wt%; and in some cases, in the range of 0.01 – 2 wt%; and in some cases, in the range of 0.1 – 1 wt%. The viscosity of the liquid composition will vary according to the particular application. For use in inkjet printing, an appropriate viscosity can be in the range of 1 – 25 mPas or 5 – 25 mPas. The interaction of the ketone solvent with the organic semiconductor material may affect the viscosity of the liquid composition. As such, the viscosity of the liquid composition may be adjusted by varying the selection of the ketone solvent and/or the organic semiconductor material, or by varying the relative amounts of each. The liquid composition may also contain any of various other types of organic materials used in the fabrication of organic electronic devices, such as OLEDs.

[0037] The liquid composition is deposited onto the surface using any suitable solution processing technique known in the art. For example, the liquid composition can be deposited using a printing process, such as inkjet printing, nozzle printing, offset printing, transfer printing, or screen printing; or for example, using a coating process, such as spray coating, spin coating, or dip coating. After deposition of the liquid composition, the ketone solvent is removed, which may be performed using any conventional method such as vacuum drying or heating.

[0038] In embodiments where the organic semiconductor material has cross-linkable functional groups, the method may further comprise cross-linking of the organic semiconductor material to form the organic layer. Cross-linking may be performed by exposing the organic semiconductor material to heat and/or actinic radiation, including UV light, gamma rays, or x-rays. Cross-linking may be carried out in the presence of an initiator that decomposes under heat or irradiation to produce free radicals or ions that initiate the cross-linking reaction. The cross-linking may be performed in-situ during fabrication of the device.

[0039] Having a cross-linked organic layer may be useful in the fabrication of multi-layered organic electronic devices by solution processing techniques. In particular, a cross-linked organic layer can avoid being dissolved, morphologically influenced, or degraded by a solvent that is deposited over it. The cross-linked organic layer may be resistant to a variety of solvents used in the fabrication of organic electronic devices, including toluene, xylene, anisole, and other substituted aromatic and aliphatic solvents. Thus, with the underlying organic layer being cross-linked and made solvent resistant, the process of solution deposition and cross-linking can be repeated to create multiple layers.

[0040] As such, in certain instances, the method further comprises forming an additional (second) organic layer by solution processing over the cross-linked (first) organic layer. This additional (second) organic layer may be a charge transporting layer (e.g., a hole transporting layer) or an emissive layer.

[0041] The liquid composition may be deposited on a variety of different types of surfaces, including surfaces that are involved in the fabrication of organic electronic devices, such as OLEDs. In certain embodiments, the surface is hydrophilic relative to the ketone solvent used in the liquid composition. This feature may be useful for improving the ability of the liquid composition to wet the surface. As described in the Examples section below, sufficient wetting of the surface by the liquid composition can improve the quality of the organic layer that is formed. The ability of the solvent to sufficiently wet the surface can be demonstrated by the wetting contact angle of a droplet of the ketone solvent that is applied on the surface (or on a comparable test surface that is made of the same material as the actual surface).

[0042] For example, FIG. 1 shows a droplet 10 of a ketone solvent applied onto an untreated, planar surface 20 made of indium tin oxide. The wetting contact angle of the droplet 10 is the angle θ between the line tangential to the droplet 10 at the interface with the surface 20 and the plane of the surface 20 itself. Generally, the droplet 10 will diffuse radially on the surface 20 and the extent of radial diffusion increases with greater wetting of the surface 20 by the solvent. Because the contact angle θ decreases as the droplet 10 diffuses radially, a lower contact angle indicates greater wetting of the surface 20 by the solvent. As such, the ketone solvent and/or the surface may be selected such that a droplet of the ketone solvent applied onto the surface (or a test surface made of the same material as the actual surface) has a contact angle of 20° or less; and in some cases, 10° or less; and in some cases, 5° or less.

[0043] In another aspect of the present invention, the liquid composition comprises a small molecule organic semiconductor material mixed in an aromatic ether solvent. The liquid composition is then deposited on a surface and dried to form the organic layer. By "aromatic ether solvent," we mean that the solvent molecule is an ether having the general formula $R - O - R'$, wherein at least one of R or R' contains an aryl, and wherein R and R' may be the same or different. In some cases, both R and R' contain an aryl. In some cases, the solvent molecule has the formula: (Aryl) - O - (Aryl), with each of the aryl groups being selected independently (i.e., they may be same or different).

[0044] The aromatic ether solvents used in the present invention may have various chemical/physical properties that make it useful for forming organic layers by solution processing techniques, such as inkjet printing. For example, the aromatic ether solvent may have a melting point of 25° C or below. In some cases, the aromatic ether solvent has a molecular weight in the range of 100 – 250. In some cases, the aromatic ether solvent has a boiling point of 150° C or greater, or 200° C or greater; and in some cases, a boiling point in the range of 150° C – 350° C or 200° C – 350° C. Boiling points in this range may be useful in preventing nozzle clogging of the inkjet print head.

[0045] Examples of aromatic ether solvents that may be suitable for use in the present invention are shown below in Table 2.

Table 2. (MW = molecular weight, BP = boiling point at 1 atm, MP = melting point at 1 atm)

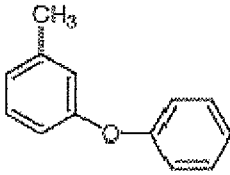
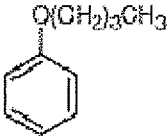
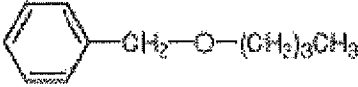
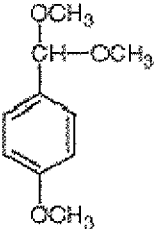
Name	Structure	MW	Density	BP (°C)	MP (°C)
3-Phenoxytoluene CAS: 3586-14-9		184	1.05	272	Liquid at RT
Butoxybenzene CAS: 1126-79-0		150	0.93	210.3	Liquid at RT
Benzyl butyl ether CAS: 588-67-0		164	0.92	220	Liquid at RT
p-Anisaldehyde dimethyl acetal CAS: 2186-92-7		182	1.07	253	Liquid at RT

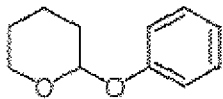
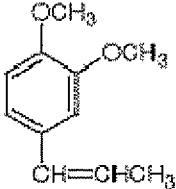
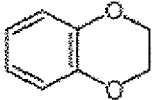
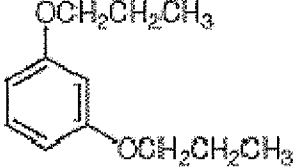
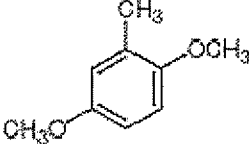
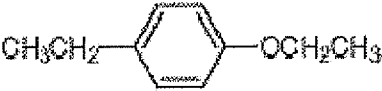
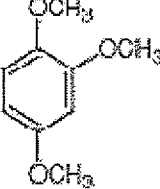
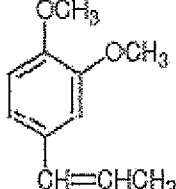
Tetrahydro-2-phenoxo-2H-pyran CAS: 4203-50-3		178	1.08	274.7	Liquid at RT
1,2-Dimethoxy-4-(1-propenyl) benzene CAS: 93-16-3		178	1.05	264	Liquid at RT
1,4-Benzodioxane CAS: 493-09-4		136	1.17	216	Liquid at RT
1,3-Dipropoxy benzene CAS: 56106-37-7		194	0.98	251	Liquid at RT
2,5-Dimethoxytoluene CAS: 24599-58-4		152	1.05	218	Liquid at RT
4-Ethylphenetole CAS: 1585-06-4		150	0.94	205	Liquid at RT
1,2,4-Trimethoxy benzene CAS: 135-77-3		168	1.13	247	Liquid at RT
4-(1-propenyl)-1,2-dimethoxybenzene CAS: 93-16-3		178	1.05	264	Liquid at RT

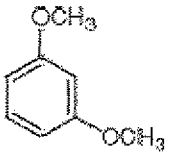
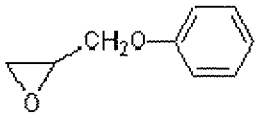
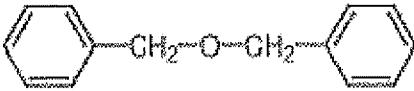
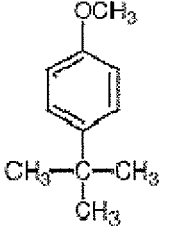
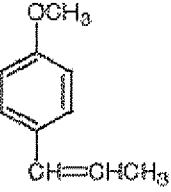
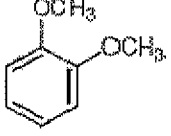
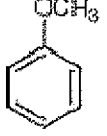
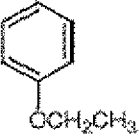
1,3-Dimethoxy benzene CAS: 151-10-0		138	1.07	217	-52
Glycidyl phenyl ether CAS: 122-60-1		150	1.11	245	3.5
Dibenzyl ether CAS: 103-50-4		198	1.04	298	4
4-tert-Butylanisole CAS: 5396-38-3		164	0.94	222	18
trans-p-propenylanisole CAS: 4180-23-8		148	0.99	235	20
1,2-Dimethoxy benzene CAS: 91-16-7		138	1.08	206.7	22.5
Anisole CAS: 100-66-3		108	1.00	153.8	-37.3
Phenetole CAS: 103-73-1		122	0.97	172	-30.2

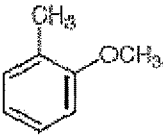
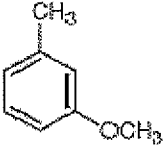
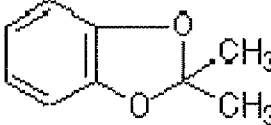
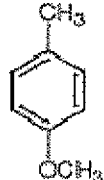
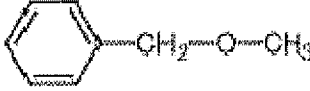
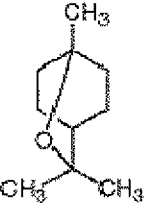
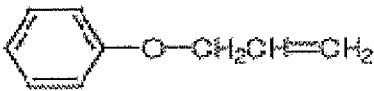
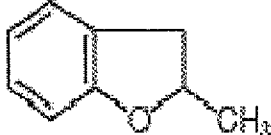
2-Methoxytoluene CAS: 578-58-5		122	0.98	171.8	-34
3-Methoxytoluene CAS: 100-84-5		122	0.97	176.5	-55.9
2,2-Dimethyl-1,3-benzodioxole CAS: 14005-14-2		150		182	3
4-Methoxytoluene CAS: 104-93-8		122	0.97	176.5	Liquid at RT
Benzyl methyl ether CAS: 538-86-3		122.16	0.97	174	Liquid at RT
1,8-Cineole CAS: 470-82-6		154	0.93	176	Liquid at RT
Allyl phenyl ether CAS: 1746-13-0		134	0.98	195	Liquid at RT
2,3-Dihydro-2-methylbenzofuran CAS: 1746-11-8		134	1.04	198	Liquid at RT

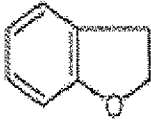
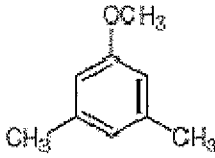
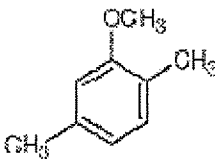
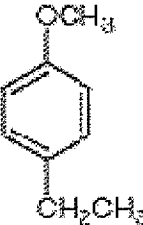
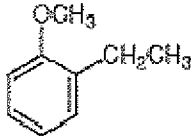
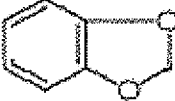
2,3-Dihydrobenzo furan CAS: 496-16-2		120	1.09	189	Liquid at RT
3,5-Dimethyl anisole CAS: 874-63-5		136	0.96	193	Liquid at RT
2,5-Dimethyl anisole CAS: 1706-11-2		136	0.97	194	Liquid at RT
4-Ethylanisole CAS: 1515-95-3		136	0.96	195	Liquid at RT
2-Ethylanisole CAS: 14804-32-1		136	0.96	187	Liquid at RT
1,2-Methylene dioxybenzene CAS: 274-09-9		122	1.19	172	Liquid at RT

[0046] In some cases, the aromatic ether solvent may be a blend of two or more aromatic ether solvents. In some cases, the liquid composition itself may use a blend of solvents, including solvents that are not aromatic ether solvents of the present invention. In such cases, the aromatic ether solvent(s) constitutes at least 50% (by volume) of the solvent volume in the liquid composition.

[0047] The organic semiconductor material may be any of those described above. In some cases, the organic semiconductor material is an emissive phosphorescent compound. Any of

various types of emissive phosphorescent compounds may be suitable, including the organometallic complexes of transition metals described in U.S. Patent No. 6,902,830 (Thompson et. al.); and U.S. Published Appln. No. 2006/0251923 (Lin et al.), No. 2007/0088167 (Lin et al.), No. 2006/0008673 (Kwong et al.), and No. 2007/0003789 (Kwong et al.), all of which are incorporated by reference herein.

[0048] The concentration of the organic semiconductor material in the liquid composition will vary according to the particular application. In certain embodiments, the organic semiconductor material is provided at a concentration that is suitable for inkjet printing. In some cases, the concentration of the organic semiconductor material is in the range of 0.01 – 10 wt%; and in some cases, in the range of 0.01 – 2 wt%; and in some cases, in the range of 0.1 – 1 wt%.

[0049] The viscosity of the liquid composition will vary according to the particular application. For use in inkjet printing, an appropriate viscosity can be in the range of 1 – 25 mPas or 5 – 25 mPas. The interaction of the aromatic ether solvent with the organic semiconductor material may affect the viscosity of the liquid composition. As such, the viscosity of the liquid composition may be adjusted by varying the selection of the aromatic ether solvent and/or the organic semiconductor material, or by varying the relative amounts of each. The liquid composition may also contain any of various other types of organic materials used in the fabrication of organic electronic devices, such as OLEDs. For example, where the liquid composition is used to make an emissive layer of an OLED, the liquid composition may further contain a host material. The organic layer may be any of those described above (e.g., a hole injection layer, a hole transporting layer, or an emissive layer in an OLED). Any of the processes described above may be used for making the organic layer with the liquid composition.

[0050] The present invention can be used in the fabrication of a variety of organic electronic devices, including organic light emitting devices, organic field-effect transistors (OFETs), organic thin-film transistors (OTFTs), organic photovoltaic devices, and organic solar cells, such as those disclosed in U.S. Appln. Publication No. 2005/0072021 (Steiger et al.), which is incorporated by reference herein. For example, FIG. 2 shows an OLED 100 that may be made using the present invention. OLED 100 has an architecture that is well-known in the art (see, for example, U.S. Appln. Publication No. 2008/0220265 to Xia et al., which is incorporated by reference herein). As seen in FIG. 2, OLED 100 has a substrate 110, an anode 115, a hole injection layer 120, a hole transport layer 125, an electron blocking layer 130, an emissive layer

135, a hole blocking layer 140, an electron transport layer 145, an electron injection layer 150, a protective layer 155, and a cathode 160. Cathode 160 is a compound cathode having a first conductive layer 162 and a second conductive layer 164. Where a first layer is described as being “over” a second layer, the first layer is disposed further away from substrate. There may be other layers between the first and second layer, unless it is specified that the first layer is “in physical contact with” the second layer. For example, a cathode may be described as being disposed “over” an anode, even though there are various organic layers in between.

[0051] The present invention may be suitable for making any of the various organic layers in an OLED. For example, referring back to FIG. 2, the present invention may be used in making the hole injection layer 120. In this case, the surface on which the liquid composition is deposited is anode 115. Anode 115 may be any suitable anode that is sufficiently conductive to transport holes to the organic layers. The material used to make anode 115 preferably has a work function higher than about 4 eV (a “high work function material”). Preferred anode materials include conductive metal oxides, such as indium tin oxide (ITO), indium zinc oxide (IZO), and aluminum zinc oxide (AlZnO). In another example, the present invention may be used for making the hole transport layer 125. In another example, the present invention may be used for making the emissive layer 135.

EXAMPLES

[0052] Specific representative embodiments of the invention will now be described, including how such embodiments may be made. It is understood that the specific methods, materials, conditions, process parameters, apparatus, and the like do not necessarily limit the scope of the invention.

[0053] Organic layers were made by inkjet printing using various solvents. The inkjet fluids were prepared by dissolving Compound 1 (a cross-linkable iridium complex) shown below in 4 different solvents at a concentration of 0.1 wt%.

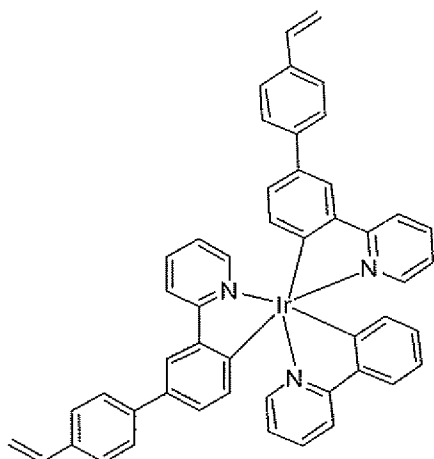

Compound 1

[0054] The solvents used were N-methylpyrrolidone (NMP), ethyl benzoate, benzyl acetate, and 1-tetralone and their boiling points and densities are shown in Table 3 below. As seen in this table, these 4 solvents have similar boiling points and densities.

Table 3.

	 NMP	 ethyl benzoate	 benzyl acetate	 1-tetralone
Boiling point (at 1 atm)	204° C	213° C	212° C	256° C
Density (gm/cm ³)	0.9	1.05	1.054	1.1

[0055] The inkjet fluids were filtered and filled into a disposable ink cartridge. The inkjet fluids for then inkjet printed onto the substrate shown in FIGS. 3A and 3B, which are schematic illustrations of a conventional substrate used in OLED fabrication. A glass substrate 30 was coated with a layer of indium tin oxide (ITO) 38 and a SiO₂ buffer layer 32. To form a matrix of pixels, a layer of polyimide was patterned on the ITO surface 38 to form compartments 36 which

define the pixels. As seen in the cross-section side view of FIG. 3B, the compartments 36 are defined by the raised polyimide partitions 34. The polyimide partitions 34 are relatively hydrophobic compared to the surface of ITO layer 38 and SiO₂ buffer layer 32, or vice versa, the surface of ITO layer 38 and the SiO₂ buffer layer 32 is relatively hydrophilic compared to the polyimide partitions 34.

[0056] Thus, in the present invention, the surface used for depositing the liquid composition may have compartments defined by partitions, with the compartments being more hydrophilic than the partitions. By this design, the compartments can be hydrophilic relative to the ketone solvent in the liquid composition and the partitions can be hydrophobic relative to the ketone solvent such that the partitions repel the liquid composition. As a result, undesirable overflow of the deposited liquid composition over the partitions and into adjacent pixel compartments can be avoided, allowing improved planarized infill of the pixel compartments. If needed, the surface can be modified by well-known surface treatment techniques (such as oxygen or CF₄ plasma treatment) to adjust its hydrophilicity.

[0057] Multiple drops of the inkjet fluid were jetted into each pixel compartment on the substrate, with the results being shown in the left column of FIGS. 4A-4C. After inkjet printing, the solvents were vacuum dried at room temperature for 10 minutes, with the results being shown in the right column of FIGS. 4A-4C. The inkjet fluid using NMP as the solvent dried out too quickly and could not be printed (and is therefore, not shown in FIG. 4).

[0058] Referring to the left panel of FIG. 4A, for the inkjet fluid using ethyl benzoate as the solvent, there was an uneven distribution of the inkjet fluid drops on the substrate. As seen in the second panel of FIG. 4A, the organic layers that were formed after drying were non-uniform, with some of the pixels being too thick and others being too thin.

[0059] Referring to the left panel of FIG. 4B, for the inkjet fluid using benzyl acetate as the solvent, there was overflow of the inkjet fluid into adjacent pixel compartments. This is believed to be the result of the solvent not being able to sufficiently wet the ITO surface.

[0060] Referring to the left panel of FIG. 4C, for the inkjet fluid using 1-tetralone as the solvent, inkjet printing resulted in a very even filling of the pixels. As seen in the second panel of FIG. 4C, after drying of the organic layers, the resulting pixels were flat and uniform. This is believed to indicate, among other things, that the 1-tetralone solvent provides the inkjet fluid with sufficient viscosity for inkjet printing and the ability to sufficiently wet the ITO surface.

[0061] Obtaining such superior results with 1-tetralone as compared to the other solvents is surprising and unexpected because the other solvents were also polar solvents, like 1-tetralone, having similar boiling points and densities as 1-tetralone. Without intending to be bound by theory, it is believed that the aromatic ring on the tetralone, the ketone functional group on the tetralone, or both in combination interacts with the organic semiconductor material to provide a liquid composition having these remarkable capabilities.

[0062] With these remarkable results, a functioning OLED was made using liquid compositions of the present invention. Inkjet fluid for making the hole injection layer was prepared by dissolving the cross-linkable HIL material (a cross-linkable iridium complex) shown below in 1-tetralone at a concentration of 0.1 wt% along with the conductivity dopant shown below. As used herein, "conductivity dopant" means an organic small molecule that increases the conductivity of an organic layer of an organic electronic device when applied to the organic layer as an additive. The weight ratio between the HIL material and the conductivity dopant was 97:3. The inkjet fluid was then filtered and filled in a disposable ink cartridge.

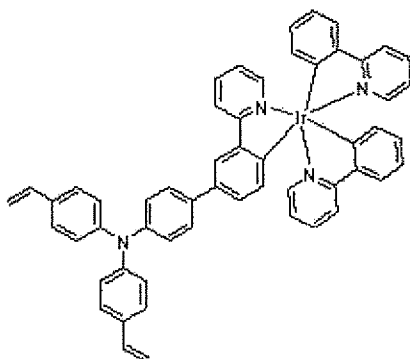

HIL material

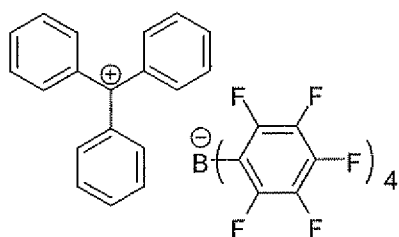

Conductivity dopant

[0063] Inkjet fluid for making the hole transporting layer was prepared by dissolving the cross-linkable HTL material shown below in 1-tetralone at a concentration of 0.2 wt%. The inkjet fluid was then filtered and filled in a disposable ink cartridge.

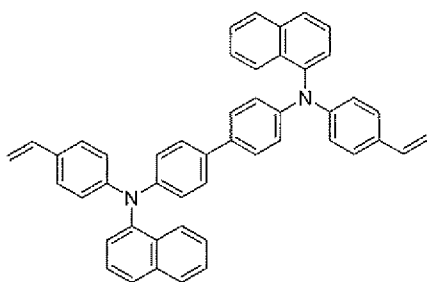

HTL material

[0064] Inkjet fluid for making the emissive layer was prepared by dissolving the EML host material shown below in 3-phenoxytoluene at a concentration of 1.0 wt% along with the phosphorescent green dopant material shown below at a host:dopant ratio of 88:12 by weight. The inkjet fluid was then filtered and filled in a disposable ink cartridge.

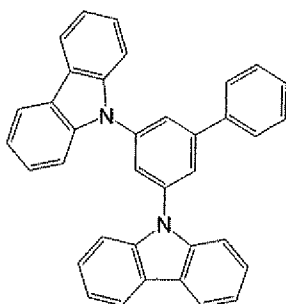

EML host material

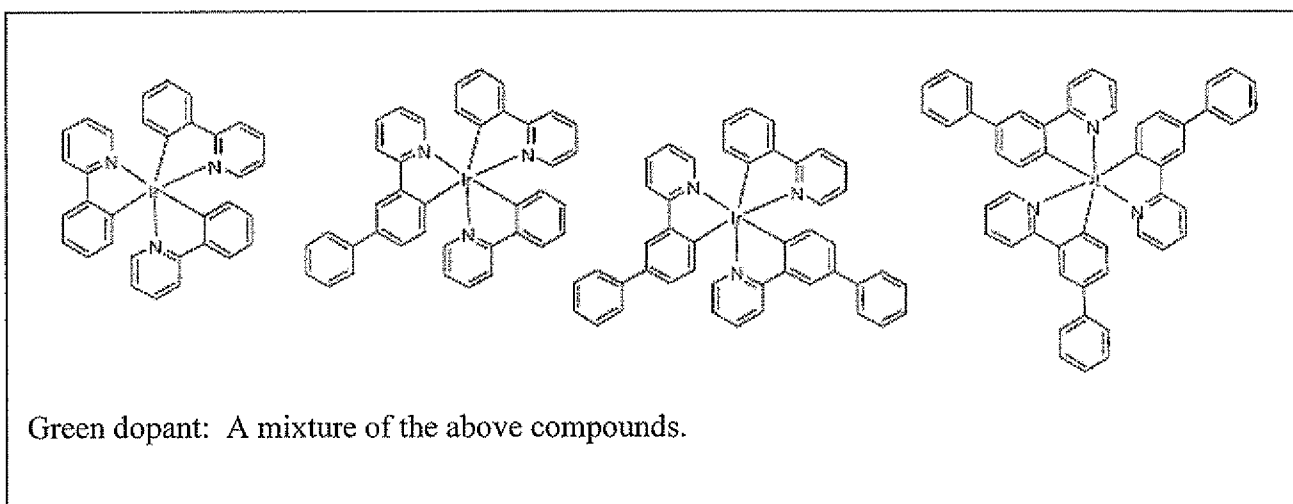

[0065] The hole injection layer was made by inkjet printing of the HIL inkjet fluid onto a substrate similar to that shown in FIG. 3, followed by vacuum drying for 10 mins. at room temperature. The resulting organic layer was then subjected to hot plate baking at 250° C for 30 mins. to remove more solvent and to cross-link the HIL material. The hole transporting layer

was made by inkjet printing of the HTL inkjet fluid onto the cross-linked hole injection layer, following by vacuum drying for 10 mins. at room temperature. The resulting organic layer was then subjected to hot plate baking at 200° C for 30 mins. to remove more solvent and to cross-link the HTL material. The emissive layer was made by inkjet printing of the EML inkjet fluid onto the cross-linked hole transport layer, following by vacuum drying for 10 mins. at room temperature, and then followed by baking at 100° C for 60 minutes.

[0066] A hole blocking layer containing the compound HPT (shown below), an electron transport layer containing Alq3 [aluminum(III)tris(8-hydroxyquinoline)], an electron injection layer containing LiF, and an aluminum electrode (cathode) were sequentially vacuum deposited in a conventional fashion.

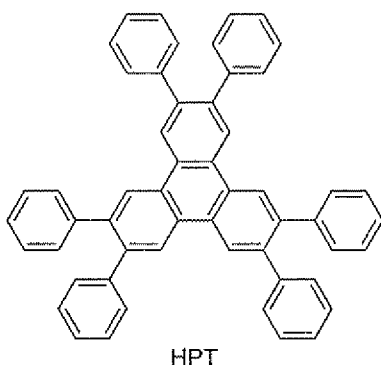

[0067] The resulting green-emitting OLED was operated under a constant DC current of 20 mA/cm² at room temperature to test its performance. FIG. 5 shows the operating lifetime of the device, depicted as a plot of luminous intensity over time. As seen in FIG. 5, the device had a 100 hour lifetime (as measured by the time elapsed for decay of brightness to 80% of the initial level of 2000 cd/m²). The device performance results are summarized in Table 4 below.

Table 4

Voltage @ 10 mA/cm ²	Luminous efficiency @ 10 mA/cm ²	CIE coordinates (x,y)	Lifetime (LT ₈₀)
8.1 volts	36.8 cd/A	(0.31, 0.64)	100 hours

[0068] The foregoing description and examples have been set forth merely to illustrate the invention and are not intended to be limiting. Each of the disclosed aspects and embodiments of the present invention may be considered individually or in combination with other aspects, embodiments, and variations of the invention. In addition, unless otherwise specified, none of the steps of the methods of the present invention are confined to any particular order of performance. Modifications of the disclosed embodiments incorporating the spirit and substance of the invention may occur to persons skilled in the art and such modifications are within the scope of the present invention.

CLAIMS

We claim:

1. A method of forming an organic layer, comprising:
providing a liquid composition comprising a small molecule organic semiconductor material mixed in an aromatic ketone solvent having a melting point of 25° C or lower; and
depositing the liquid composition on a surface.
2. The method of claim 1, wherein the concentration of the organic semiconductor material is in the range of 0.01 – 10 wt%.
3. The method of claim 2, wherein the concentration of the organic semiconductor material is in the range of 0.01 – 2 wt%.
4. The method of claim 1, wherein the aromatic ketone solvent is a tetralone solvent.
5. The method of claim 1, wherein the aromatic ketone solvent has a boiling point of at least 150° C at 1 atm.
6. The method of claim 5, wherein the aromatic ketone solvent has a boiling point in the range of 150° – 350° C at 1 atm.
7. The method of claim 1, wherein the aromatic ketone solvent has a molecular weight in the range of 100 – 250.
8. The method of claim 1, wherein the step of depositing is performed by a printing process.
9. The method of claim 8, wherein the printing process is inkjet printing.
10. The method of claim 1, further comprising removing the aromatic ketone solvent by heating or vacuum drying after depositing the liquid composition.

11. The method of claim 1, wherein the liquid composition has a viscosity in the range of 1 – 25 mPas.
12. The method of claim 1, wherein a droplet of the aromatic ketone solvent on the surface has a wetting contact angle of 20° or less.
13. The method of claim 1, wherein the surface has a plurality of compartments defined by raised partitions, wherein the compartments are hydrophilic to the aromatic ketone solvent and the partitions are hydrophobic to the aromatic ketone solvent.
14. The method of claim 1, wherein the organic semiconductor material has one or more cross-linkable functional groups.
15. The method of claim 14, wherein the organic semiconductor material is a charge transport compound.
16. The method of claim 15, wherein the organic semiconductor material is a cross-linkable iridium complex.
17. The method of claim 14, further comprising cross-linking the organic semiconductor material after depositing the liquid composition.
18. A method of making an organic electronic device comprising the step of forming an organic layer by the method of claim 1.
19. The method of claim 18, wherein the organic electronic device is an organic light emitting device comprising an anode and a cathode.
20. The method of claim 19, wherein the organic layer is a hole injection layer disposed between the anode and the cathode.

21. The method of claim 19, wherein the organic layer is a hole transport layer disposed between the anode and the cathode.
22. The method of claim 19, wherein the surface is the surface of the anode.
23. The method of claim 18, wherein the organic layer is a first organic layer, and further comprising the step of forming a second organic layer over the first organic layer by solution processing.
24. The method of claim 23, wherein the first organic layer is a hole injection layer and the second organic layer is an emissive layer.
25. The method of claim 23, wherein the first organic layer is a hole injection layer and the second organic layer is a hole transporting layer.
26. The method of claim 18, wherein the organic electronic device is an organic field-effect transistor.
27. The method of claim 18, wherein the organic electronic device is an organic thin-film transistor.
28. The method of claim 18, wherein the organic electronic device is an organic solar cell.
29. An organic electronic device having an organic layer, wherein the organic layer is made by the method of claim 1.
30. The organic electronic device of claim 29, wherein the organic electronic device is an organic light emitting device.

31. The organic electronic device of claim 29, wherein the organic electronic device is an organic field-effect transistor.
32. The organic electronic device of claim 29, wherein the organic electronic device is an organic thin-film transistor.
33. The organic electronic device of claim 29, wherein the organic electronic device is an organic solar cell.
34. A liquid composition comprising:
 - an aromatic ketone solvent having a melting point of 25° C or lower; and
 - a small molecule organic semiconductor material mixed in the aromatic ketone solvent at a concentration in the range of 0.01 – 10 wt%.
35. The liquid composition of claim 34, wherein the concentration of the organic semiconductor material is in the range of 0.01 – 2 wt%.
36. The liquid composition of claim 34, wherein the aromatic ketone solvent is a tetralone solvent.
37. The liquid composition of claim 34, wherein the aromatic ketone solvent has a boiling point of at least 150° C at 1 atm.
38. The liquid composition of claim 37, wherein the aromatic ketone solvent has a boiling point in the range of 150° – 350° C at 1 atm.
39. The liquid composition of claim 34, wherein the aromatic ketone solvent has a molecular weight in the range of 100 – 250.
40. The liquid composition of claim 34, wherein the liquid composition has a viscosity in the range of 1 – 25 mPas.

41. The liquid composition of claim 34, wherein a droplet of the aromatic ketone solvent applied onto an untreated, planar surface of indium tin oxide has a wetting contact angle of 20° or less.
42. The liquid composition of claim 34, wherein the organic semiconductor material has one or more cross-linkable functional groups.
43. The liquid composition of claim 42, wherein the organic semiconductor material is a charge transport compound.
44. The liquid composition of claim 43, wherein the organic semiconductor material is a cross-linkable organometallic iridium complex.
45. The liquid composition of claim 34, further comprising a conductivity dopant.
46. A method of forming an organic layer, comprising:
providing a liquid composition comprising a small molecule organic semiconductor material mixed in an aromatic ether solvent having a melting point of 25° C or less; and
depositing the liquid composition on a surface.
47. The method of claim 46, wherein the concentration of the organic semiconductor material is in the range of 0.01 – 10 wt%.
48. The method of claim 47, wherein the concentration of the organic semiconductor material is in the range of 0.01 – 2 wt%.
49. The method of claim 46, wherein the aromatic ether solvent is 3-phenoxytoluene.

50. The method of claim 46, wherein the aromatic ether solvent has a boiling point of at least 150° C at 1 atm.
51. The method of claim 50, wherein the aromatic ether solvent has a boiling point in the range of 150° - 350° C. at 1 atm.
52. The method of claim 46, wherein the aromatic ether solvent has a molecular weight in the range of 100 – 250.
53. The method of claim 46, wherein the step of depositing is performed by inkjet printing.
54. The method of claim 46, wherein the organic semiconductor material is an organometallic complex of a transition metal.
55. The method of claim 46, wherein the organic semiconductor material is an emissive phosphorescent compound.
56. The method of claim 55, wherein the liquid composition further comprises a host compound for the phosphorescent compound.
57. The method of claim 56, wherein the host compound is a carbazole-containing compound.
58. The method of claim 46, wherein the organic layer is a first organic layer, and further comprising the step of forming a second organic layer over the first organic layer by solution processing.
59. The method of claim 58, wherein forming the second organic layer comprises:
providing a second liquid composition comprising a small molecule organic semiconductor material mixed in an aromatic ketone solvent having a melting point of 25° C or lower; and

depositing the second liquid composition over the first organic layer.

60. The method of claim 59, wherein the first organic layer is an emissive layer and the second organic layer is a hole injection layer.

61. The method of claim 59, wherein the first organic layer is an emissive layer and the second organic layer is a hole transporting layer.

62. A method of making an organic light emitting device having an anode, a cathode, and an organic layer disposed between the anode and the cathode, wherein the organic layer is formed by the method of claim 46.

63. The method of claim 62, wherein the organic layer is an emissive layer.

64. The method of claim 62, wherein the organic layer is a hole transporting layer.

65. An organic light emitting device having an anode, a cathode, and an organic layer disposed between the anode and the cathode, wherein the organic layer is formed by the method of claim 46.

66. A liquid composition comprising:
an aromatic ether solvent having a melting point of 25° C or less; and
a small molecule organic semiconductor material mixed in the aromatic ether solvent at a concentration in the range of 0.01 – 10 wt%.

67. The liquid composition of claim 66, wherein the concentration of the organic semiconductor material is in the range of 0.01 – 2 wt%.

68. The liquid composition of claim 66, wherein the aromatic ether solvent is 3-phenoxytoluene.

69. The liquid composition of claim 66, wherein the aromatic ether solvent has a boiling point of at least 150° C at 1 atm.

70. The liquid composition of claim 69, wherein the aromatic ether solvent has a boiling point in the range of 150° – 350° C at 1 atm.

71. The liquid composition of claim 66, wherein the aromatic ether solvent has a molecular weight in the range of 100 – 250.

72. The liquid composition of claim 66, wherein the organic semiconductor material is an emissive phosphorescent compound.

73. The liquid composition of claim 72, wherein the emissive phosphorescent compound is an organometallic complex of a transition metal.

74. The liquid composition of claim 72, wherein the liquid composition further comprises a host compound for the phosphorescent compound.

75. The liquid composition of claim 74, wherein the host compound is a carbazole-containing compound.

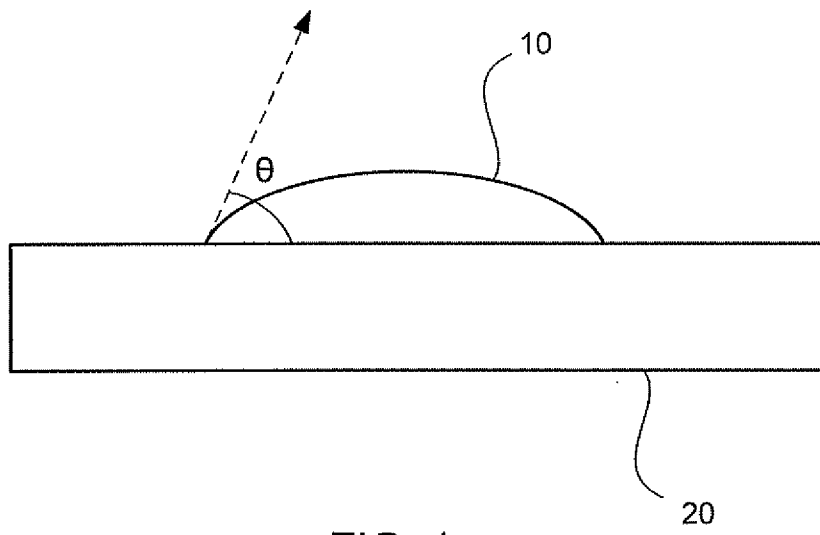

FIG. 1

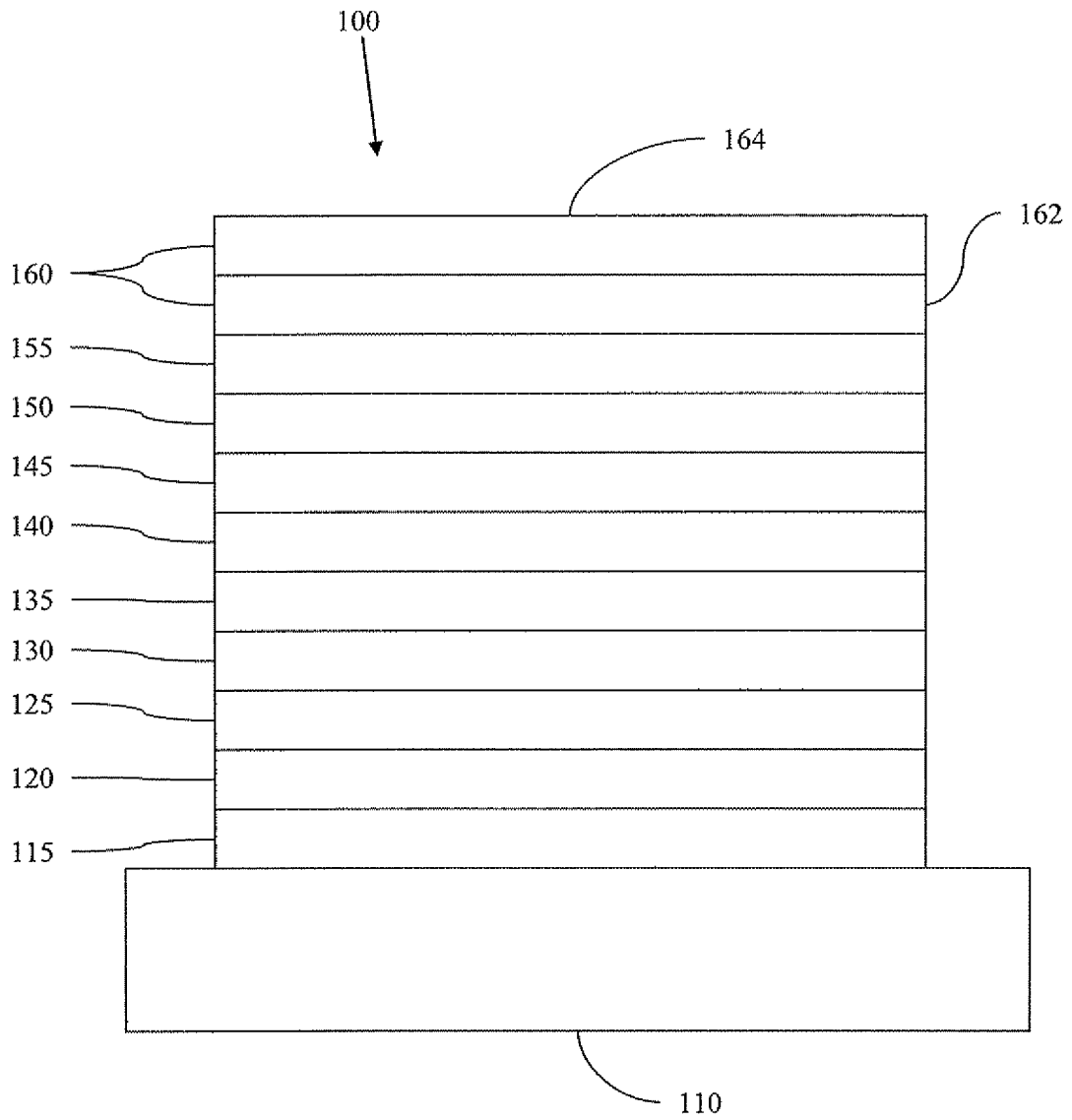
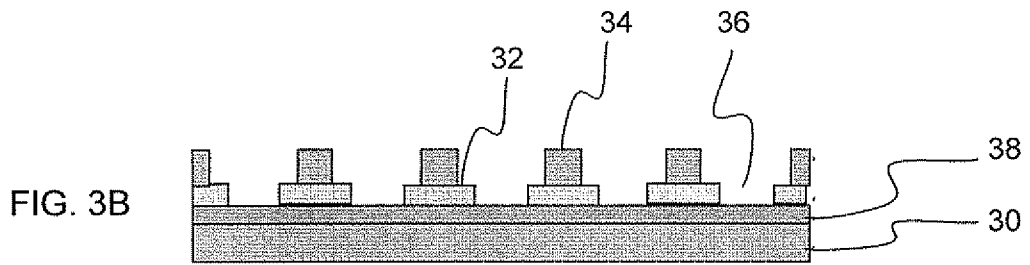
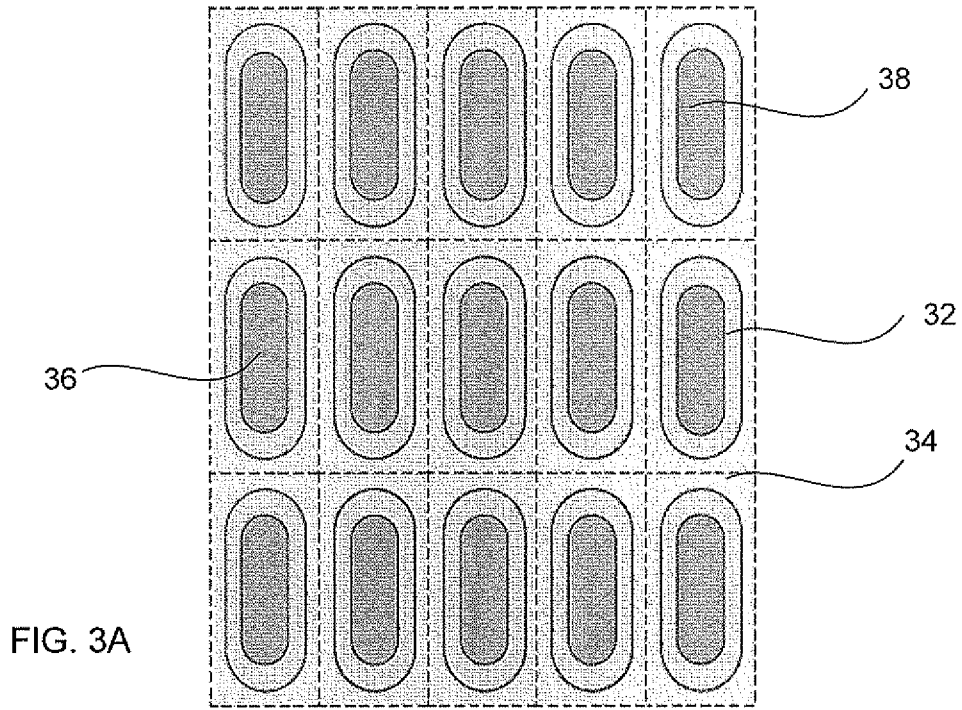
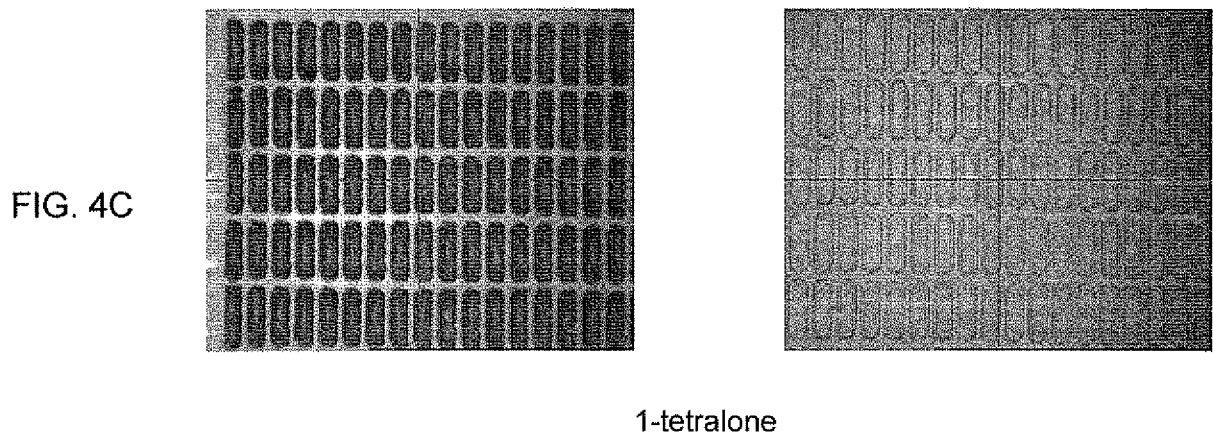
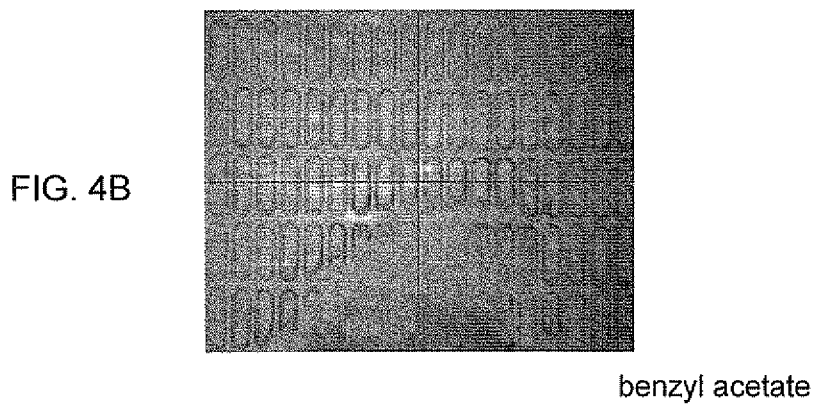
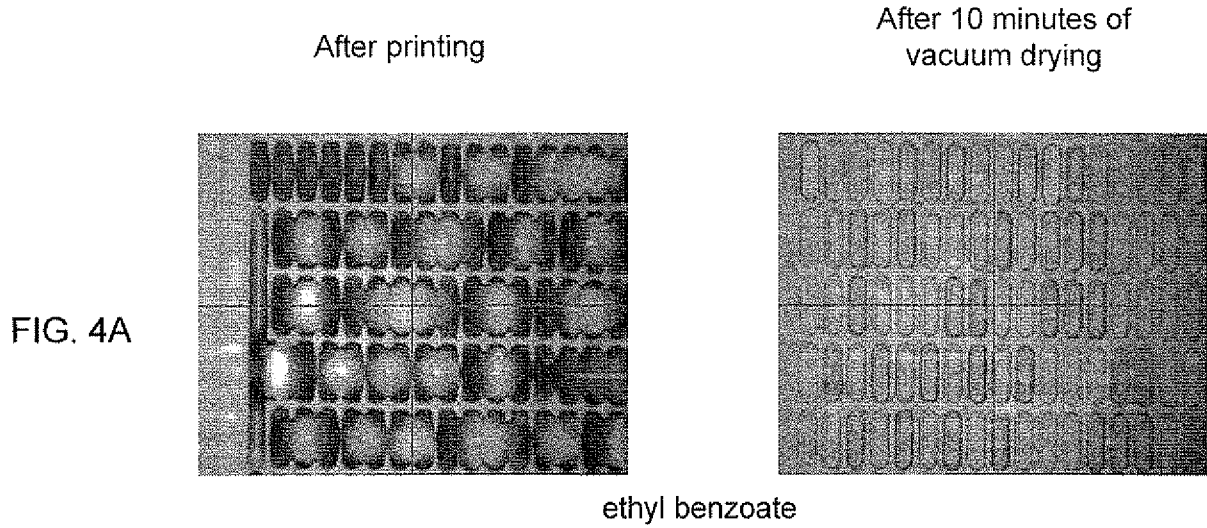

FIG. 2





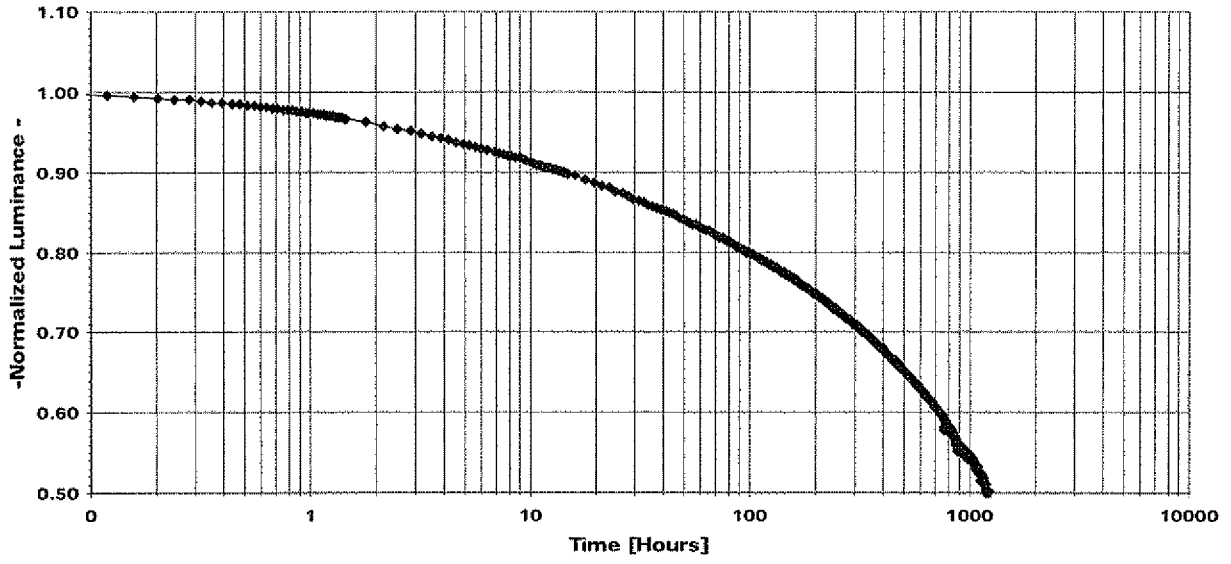

FIG. 5

INTERNATIONAL SEARCH REPORT

International application No
PCT/US2010/023540

A. CLASSIFICATION OF SUBJECT MATTER
INV. H01L51/00 B41J2/21 C09D11/00

According to International Patent Classification (IPC) or to both national classification and IPC

B. FIELDS SEARCHED

Minimum documentation searched (classification system followed by classification symbols)
H01L B41J C09D

Documentation searched other than minimum documentation to the extent that such documents are included in the fields searched

Electronic data base consulted during the international search (name of data base and, where practical, search terms used)

EPO-Internal

C. DOCUMENTS CONSIDERED TO BE RELEVANT

Category*	Citation of document, with indication, where appropriate, of the relevant passages	Relevant to claim No.
X	WO 2008/105472 A1 (IDEMITSU KOSAN CO [JP]; SONY CORP [JP]; TAKESHIMA MOTOHIRO [JP]; INOUE) 4 September 2008 (2008-09-04)	46-53, 62-71
Y	paragraph [0131] - paragraph [0143] paragraphs [0070], [0129], [0153]	1-3,5-9, 11, 18-21, 26-35, 37-40
X,P	& EP 2 117 061 A1 (IDEMITSU KOSAN CO [JP]; SONY CORP [JP]) 11 November 2009 (2009-11-11)	46-53, 62-71
Y,P	paragraph [0131] - paragraph [0143] paragraphs [0070], [0129], [0153]	1-3,5-9, 11, 18-21, 26-35, 37-40
	----- -/--	

Further documents are listed in the continuation of Box C.

See patent family annex.

* Special categories of cited documents :

- "A" document defining the general state of the art which is not considered to be of particular relevance
- "E" earlier document but published on or after the international filing date
- "L" document which may throw doubts on priority claim(s) or which is cited to establish the publication date of another citation or other special reason (as specified)
- "O" document referring to an oral disclosure, use, exhibition or other means
- "P" document published prior to the international filing date but later than the priority date claimed

- "T" later document published after the international filing date or priority date and not in conflict with the application but cited to understand the principle or theory underlying the invention
- "X" document of particular relevance; the claimed invention cannot be considered novel or cannot be considered to involve an inventive step when the document is taken alone
- "Y" document of particular relevance; the claimed invention cannot be considered to involve an inventive step when the document is combined with one or more other such documents, such combination being obvious to a person skilled in the art.
- "&" document member of the same patent family

Date of the actual completion of the international search

19 March 2010

Date of mailing of the international search report

01/04/2010

Name and mailing address of the ISA/

European Patent Office, P.B. 5818 Patentlaan 2
NL - 2280 HV Rijswijk
Tel. (+31-70) 340-2040,
Fax: (+31-70) 340-3016

Authorized officer

Pusch, Catharina

INTERNATIONAL SEARCH REPORT

International application No

PCT/US2010/023540

C(Continuation). DOCUMENTS CONSIDERED TO BE RELEVANT

Category*	Citation of document, with indication, where appropriate, of the relevant passages	Relevant to claim No.
X	JP 2007 302624 A (MITSUBISHI CHEM CORP) 22 November 2007 (2007-11-22)	46-48, 50-52, 58,62, 64-67, 69-71
Y	paragraphs [0049], [0126], [0136], [0139] paragraph [0221] - paragraph [0230]	1-3,5-9, 11,15, 18-24, 26-35, 37-40, 43,45
Y	----- GB 2 451 201 A (SUMITOMO CHEMICAL CO [JP]) 21 January 2009 (2009-01-21) page 25, line 15 - line 16 page 26, line 6 page 27, line 5 - line 11 page 29, line 5 page 29, line 14 - line 15	1-3,5-9, 11,15, 18-24, 26-35, 37-40, 43,45
A	WO 02/069119 A1 (CAMBRIDGE DISPLAY TECH [GB]; LYON PETER JOHN [GB]; CARTER JULIAN CHARL) 6 September 2002 (2002-09-06) page 6, line 17 - line 30	1,34
A	----- EP 1 589 595 A2 (JSR CORP [JP]) 26 October 2005 (2005-10-26) paragraph [0054] - paragraph [0057] paragraph [0071] - paragraph [0074]	1,34

INTERNATIONAL SEARCH REPORT

Information on patent family members

International application No PCT/US2010/023540

Patent document cited in search report	Publication date	Patent family member(s)	Publication date
WO 2008105472 A1	04-09-2008	EP 2117061 A1	11-11-2009
EP 2117061 A1	11-11-2009	WO 2008105472 A1	04-09-2008
JP 2007302624 A	22-11-2007	NONE	
GB 2451201 A	21-01-2009	JP 2007288139 A WO 2007111359 A1 KR 20080113049 A US 2009166644 A1	01-11-2007 04-10-2007 26-12-2008 02-07-2009
WO 02069119 A1	06-09-2002	AU 2002236023 A8 EP 1364420 A2 JP 4347569 B2 JP 2004532096 T	12-09-2002 26-11-2003 21-10-2009 21-10-2004
EP 1589595 A2	26-10-2005	JP 2005306998 A KR 20060047315 A US 2005238917 A1	04-11-2005 18-05-2006 27-10-2005