

[54] METHOD OF AND APPARATUS FOR PACKAGING FLEXIBLE ARTICLES

[75] Inventors: Orrin H. Besserdich; Donald C. Crawford, both of Green Bay, Wis.

[73] Assignee: FMC Corporation, San Jose, Calif.

[22] Filed: Nov. 12, 1971

[21] Appl. No.: 198,385

[52] U.S. Cl. 53/26, 53/21 FW, 53/62, 53/120, 53/159

[51] Int. Cl. B65b 5/06, B65b 35/50, B65b 35/54

[58] Field of Search 53/59-61, 53/21 FW, 26, 117, 120, 159; 93/93 DP; 214/6 D

[56] References Cited

UNITED STATES PATENTS

3,656,271	4/1972	O'Shea.....	53/120 X
3,593,624	7/1971	Dufour.....	214/6 D

Primary Examiner—Robert L. Spruill
Attorney—F. W. Anderson et al.

[57] ABSTRACT

A packing method, and apparatus for effecting the method, wherein a stack of flexible articles such as film bags are positioned over a support having a narrow aperture extending from one edge of the stack to the opposed edge so that the central portion of the stack is unsupported. An open top carton is positioned beneath the aperture, and an overhead plunger with line contact on the top of the stack pushes downward in alignment with the aperture to buckle the stack of bags and force them through the aperture into the carton. While one stack of bags is being packed, some of the first bags of the next stack are diverted from the conveying path, and are followed by subsequent bags. This diverting operation thus allows time for the packaging operation without interruption of the continuous output of the machine supplying the bags.

6 Claims, 21 Drawing Figures

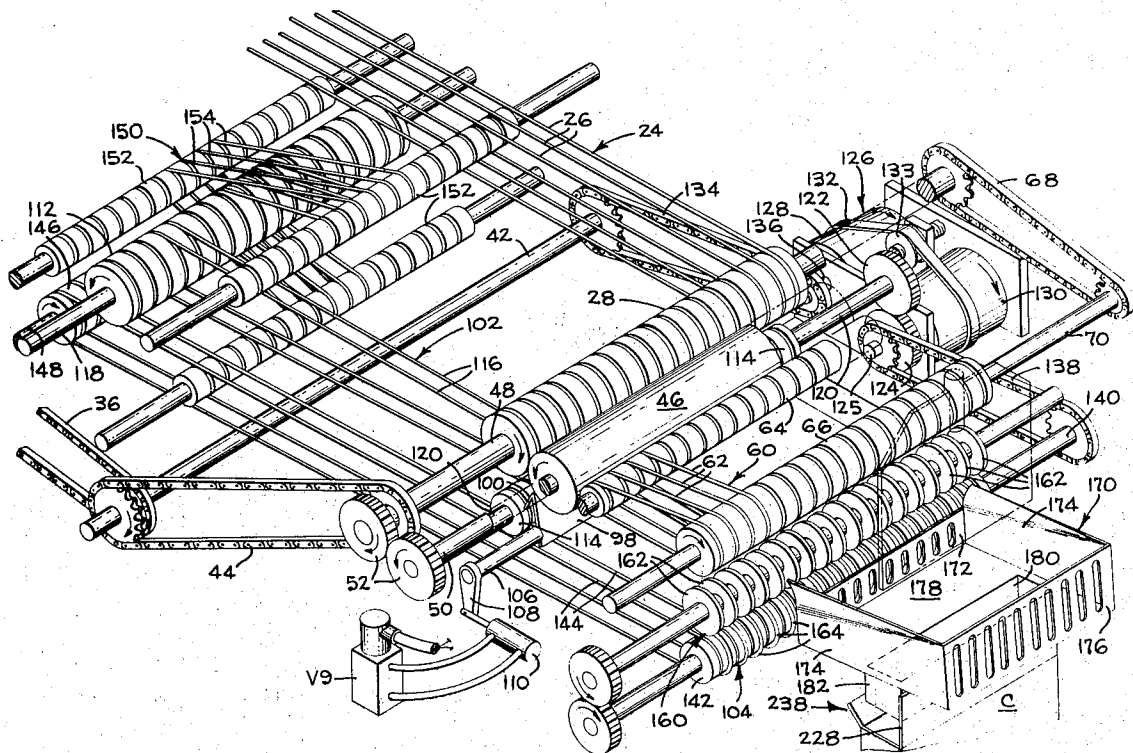

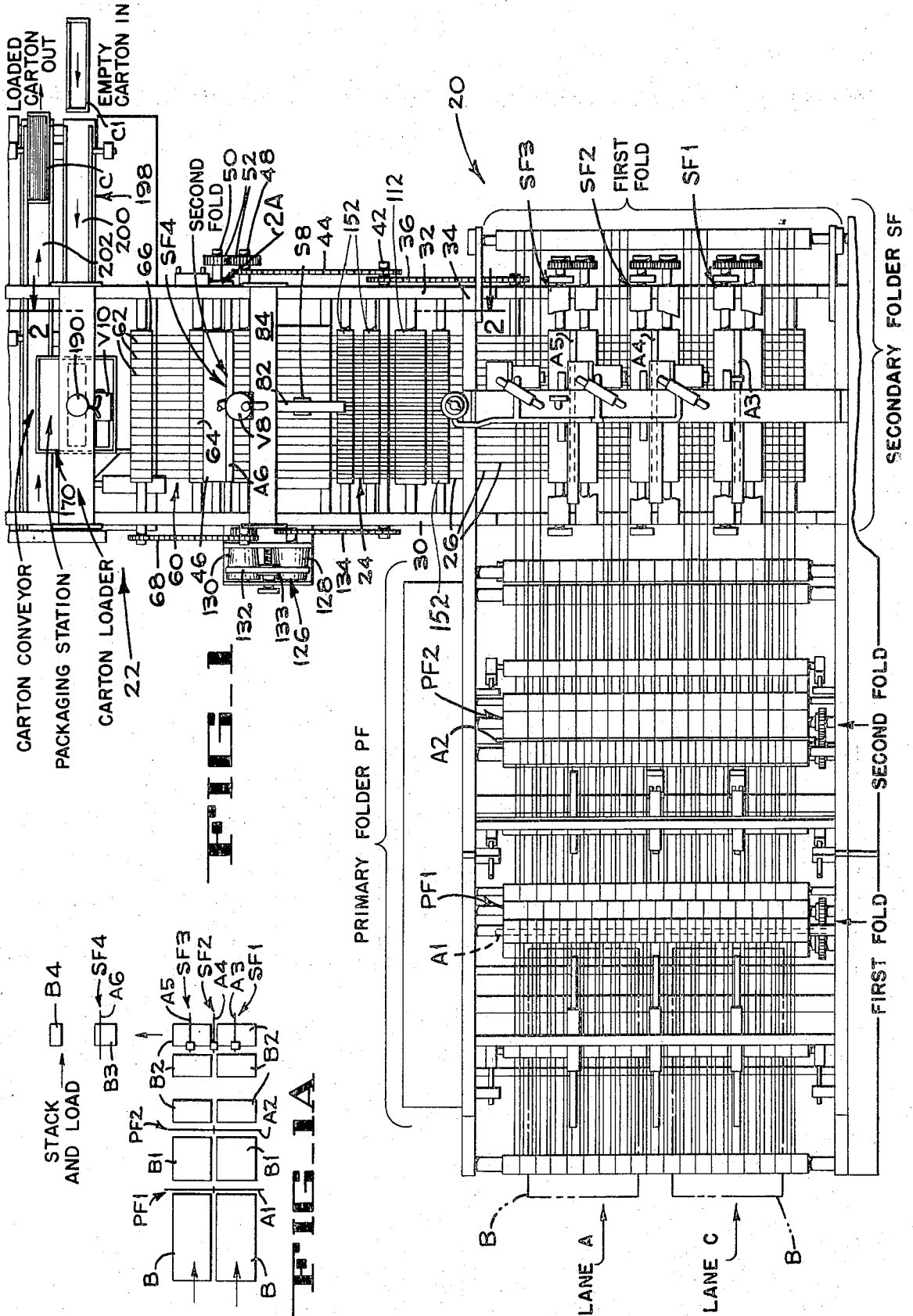

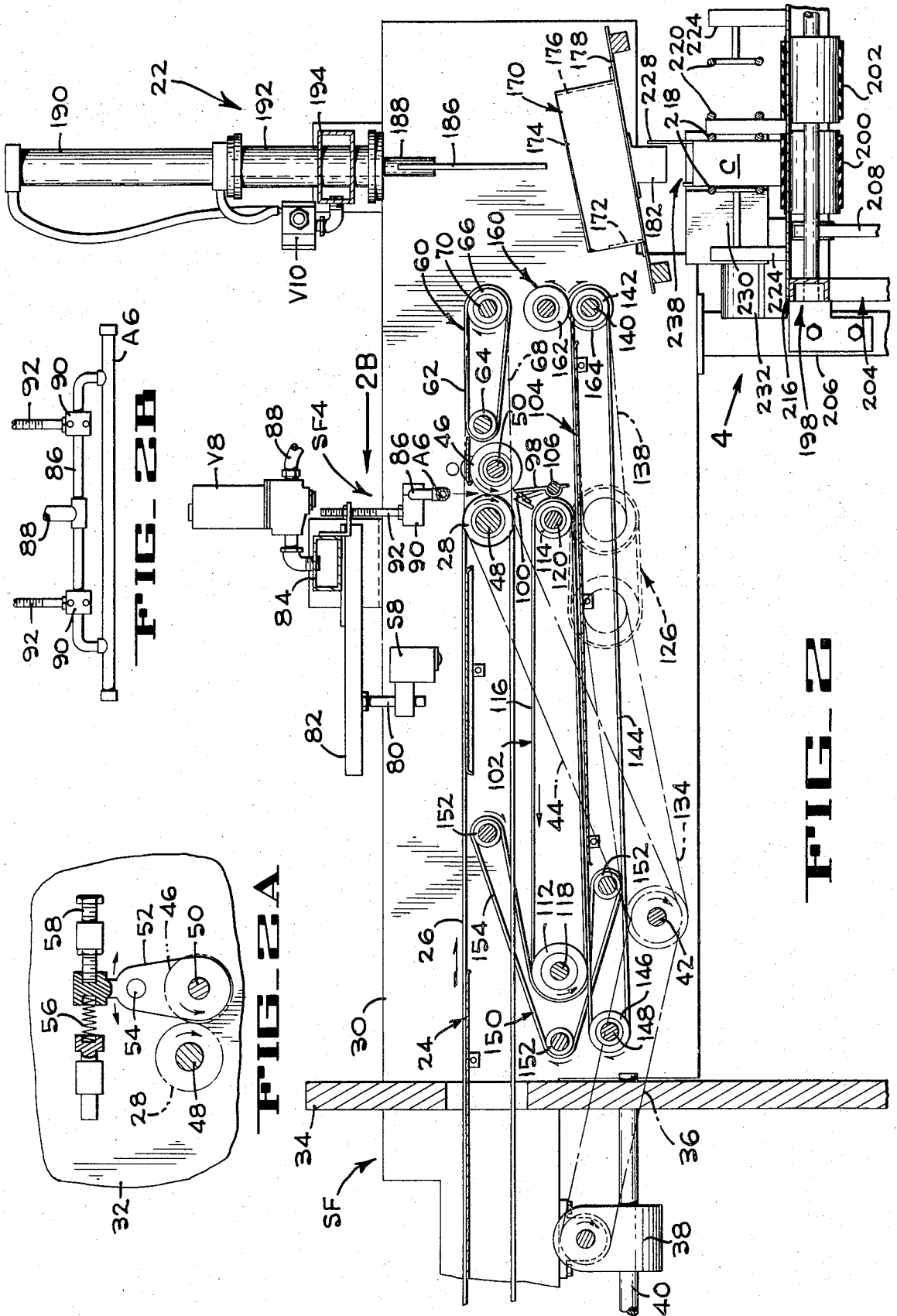
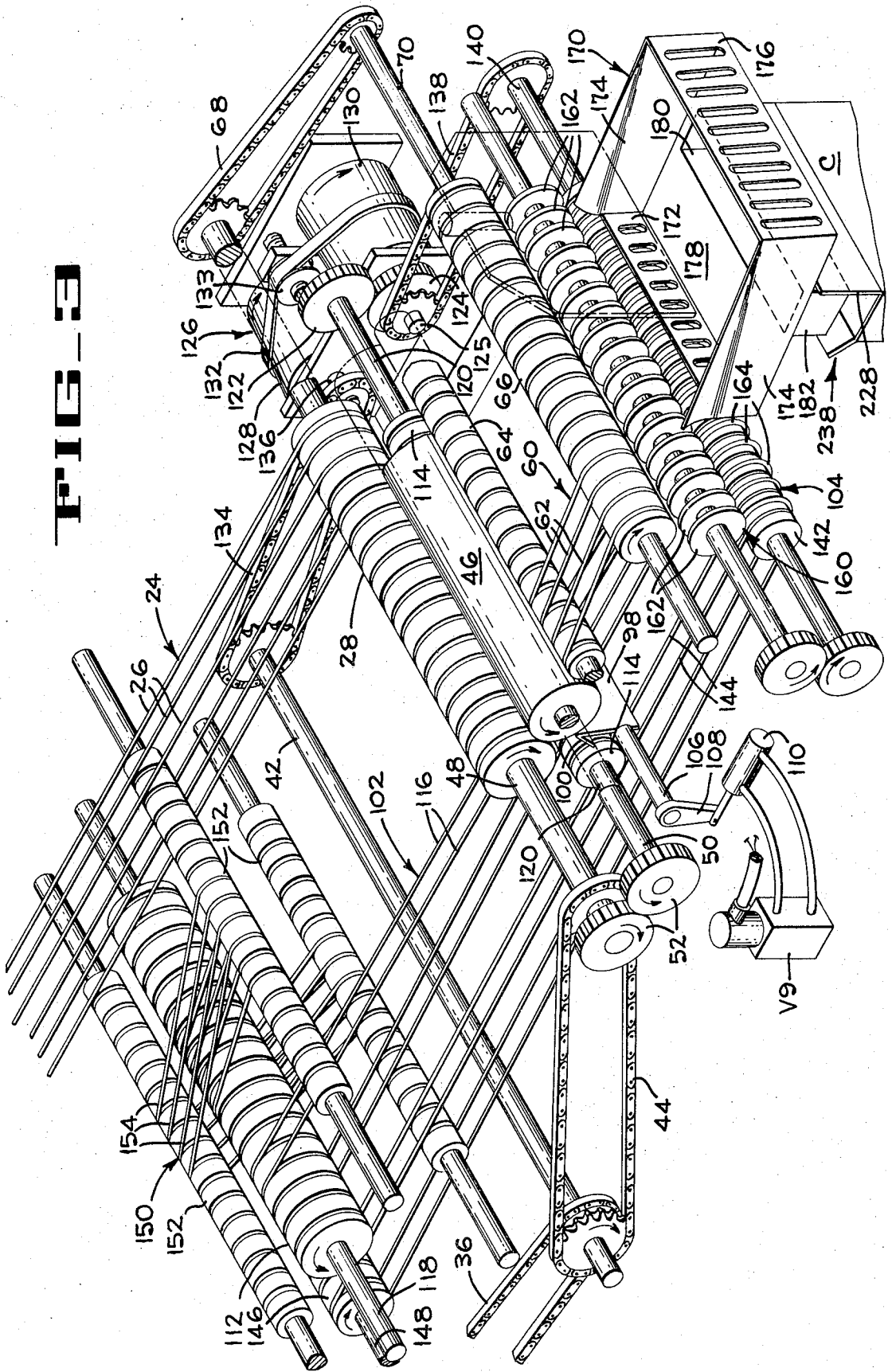
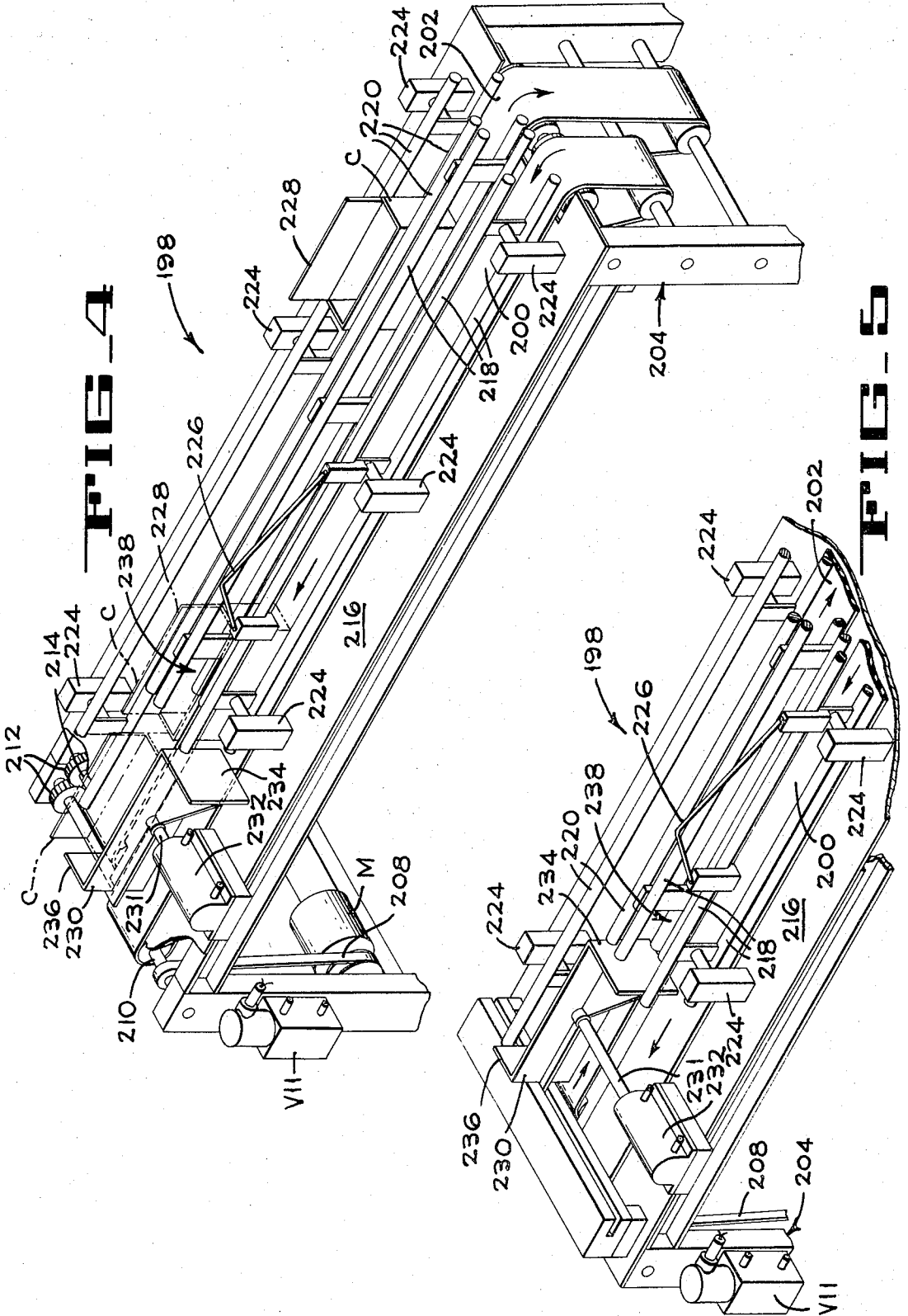
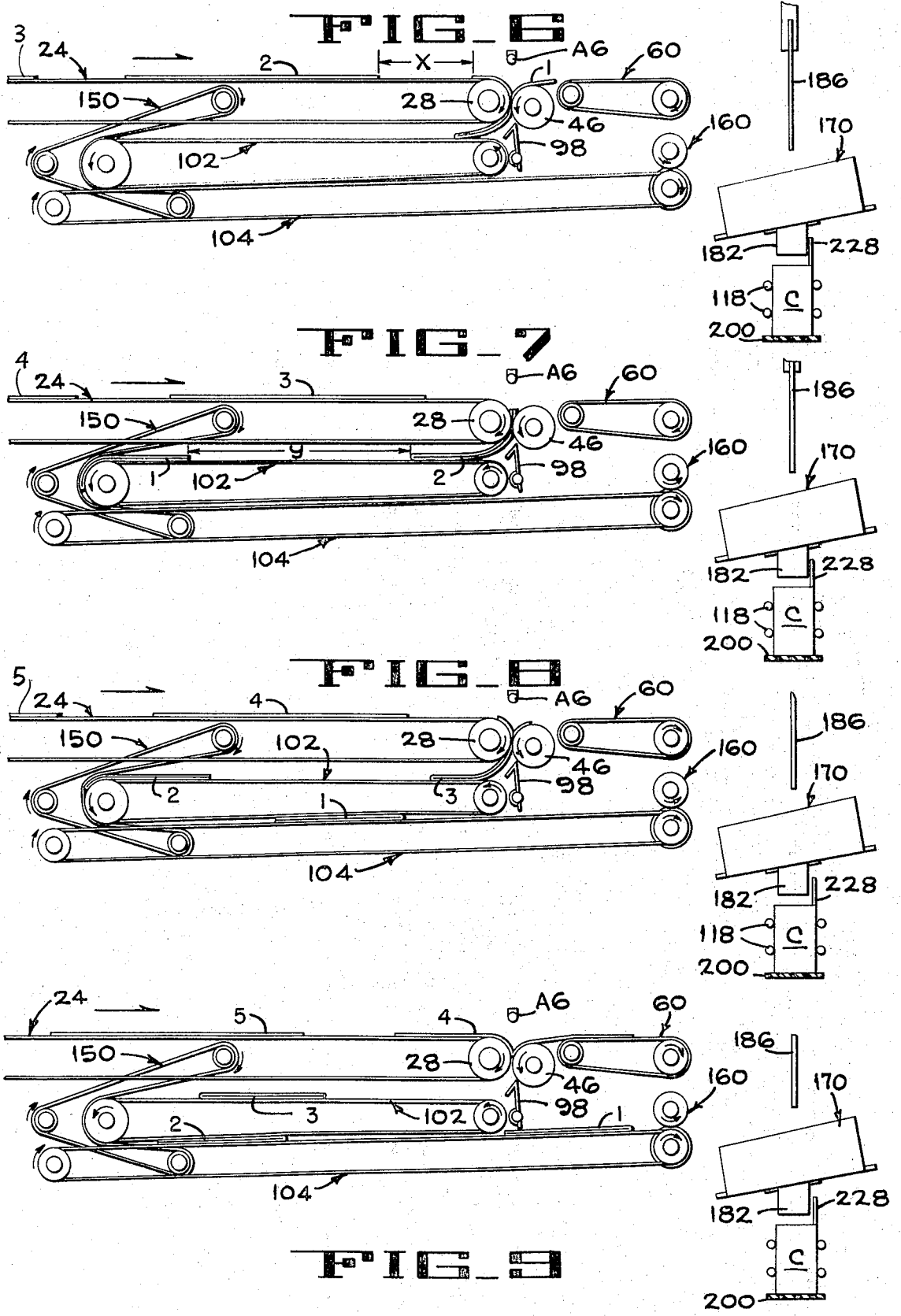
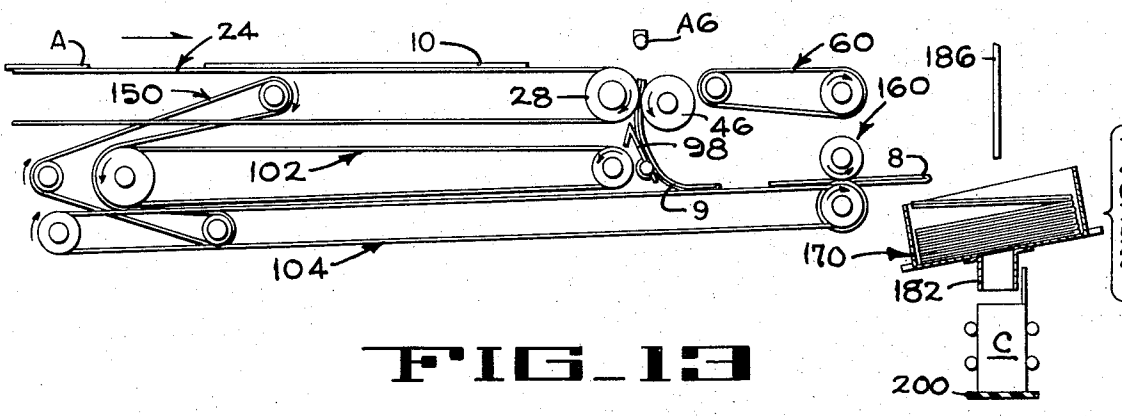
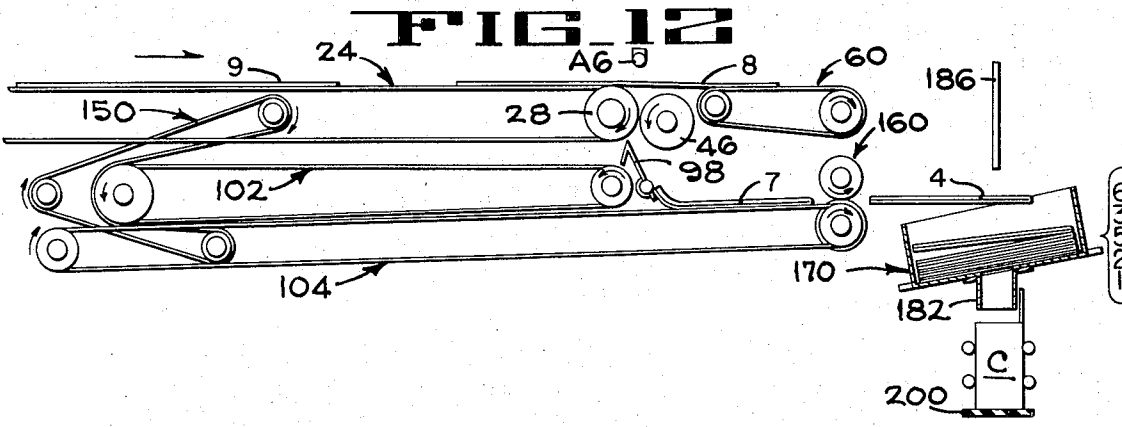
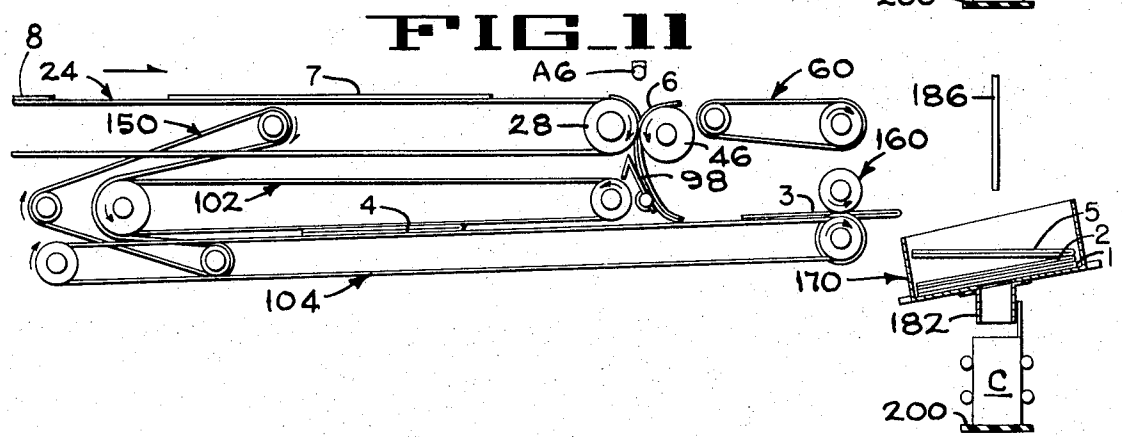
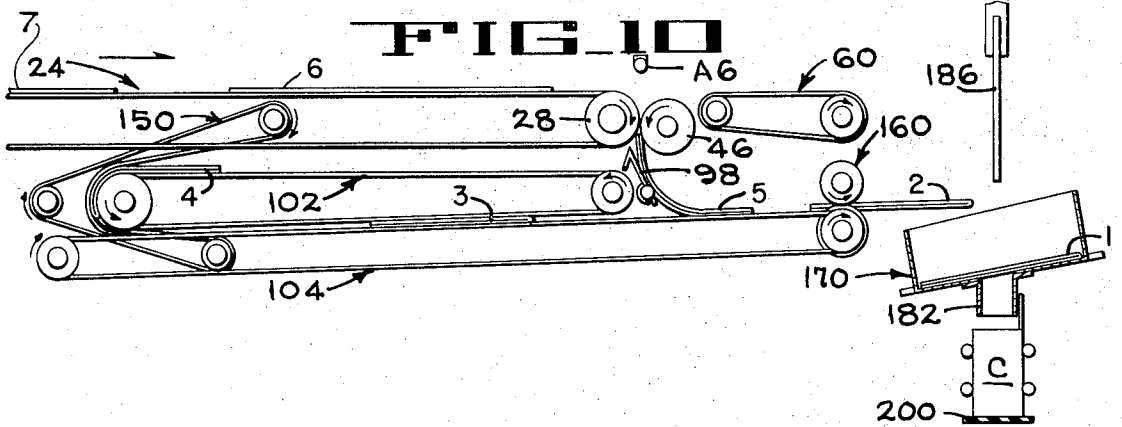

FIG-3









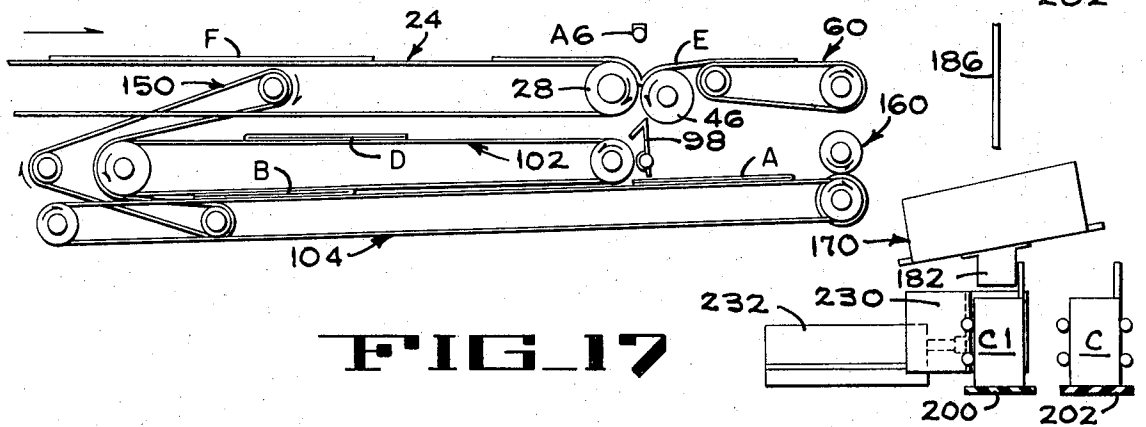
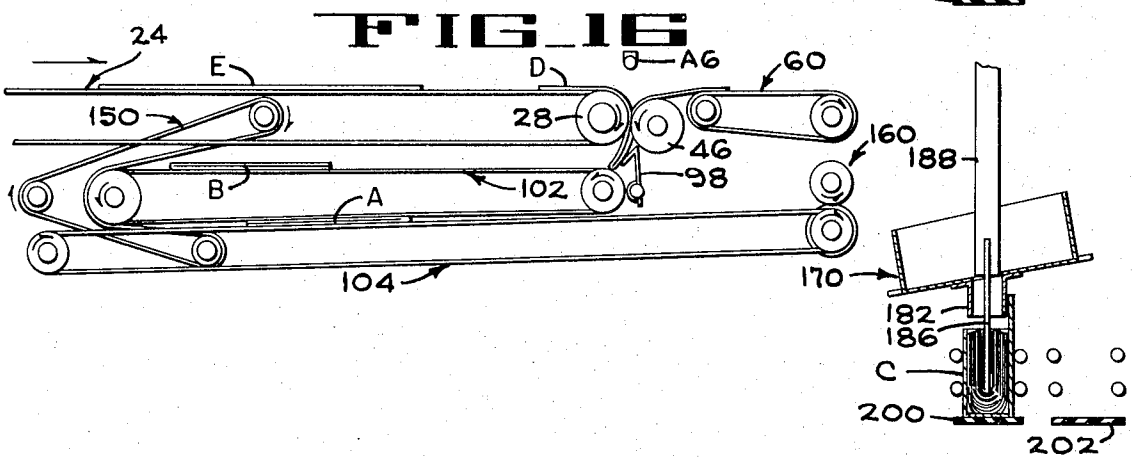
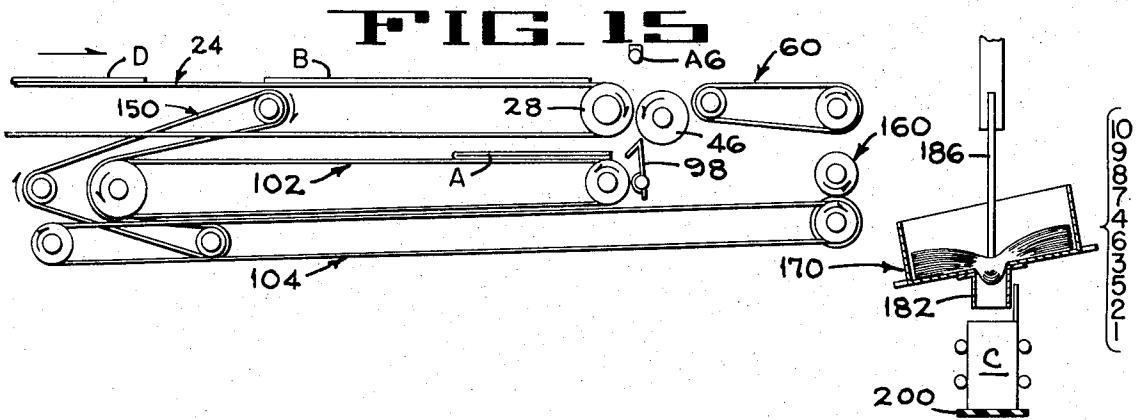
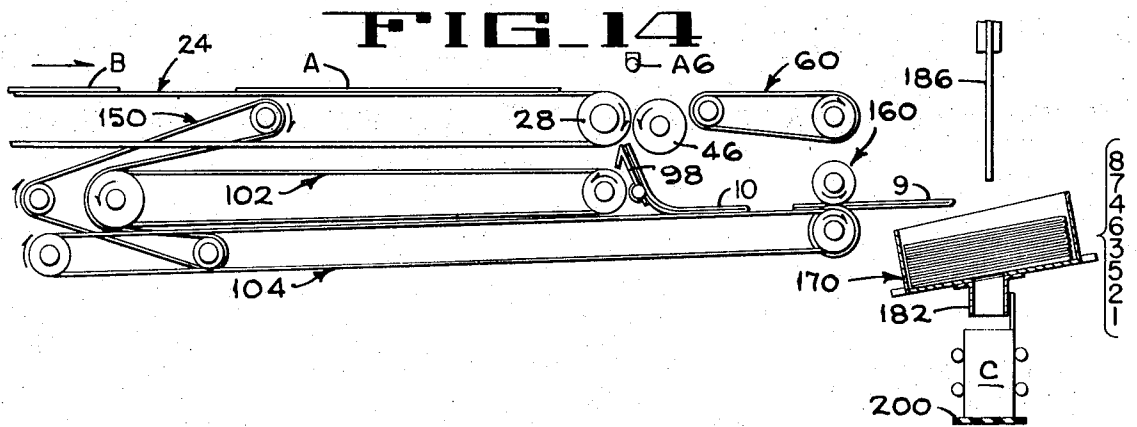

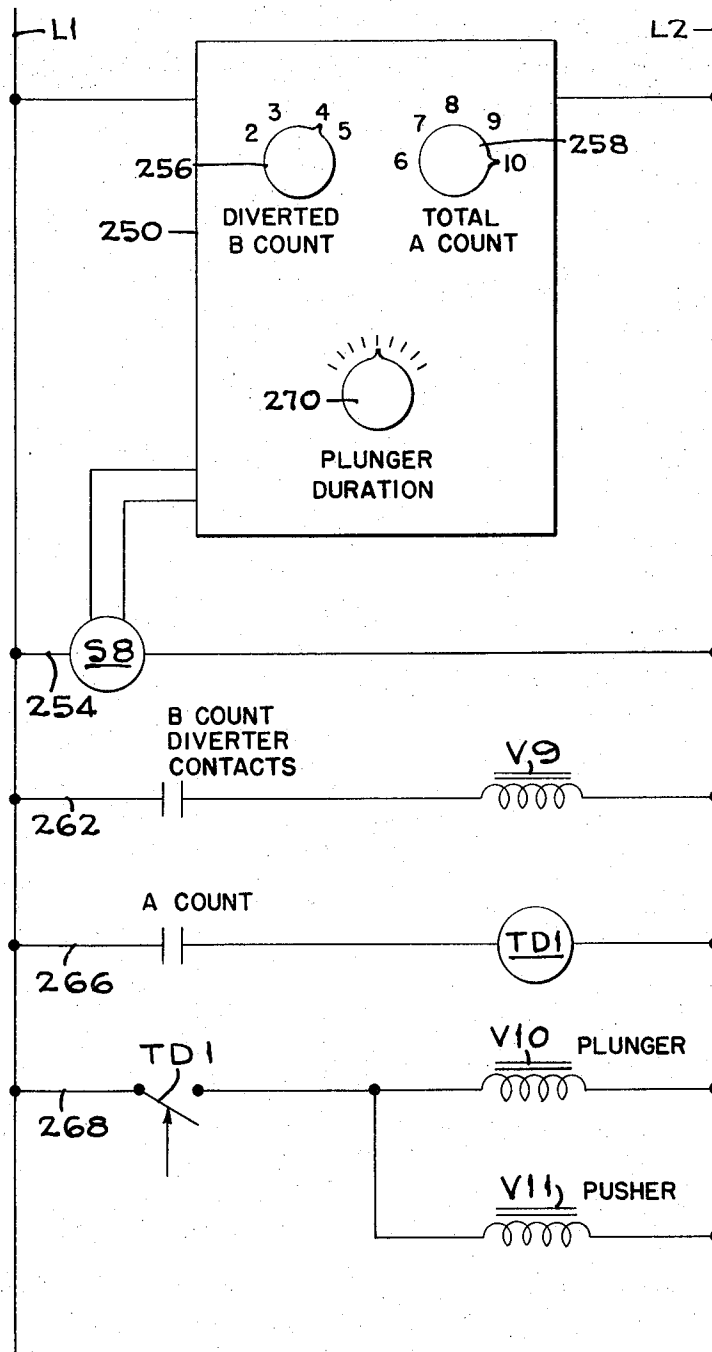

FIG. 18

METHOD OF AND APPARATUS FOR PACKAGING FLEXIBLE ARTICLES

BACKGROUND OF THE INVENTION

The field of the present invention is packaging apparatus for placing a stack of flexible, flat articles such as film bags into a carton. More specifically, the present invention has special utility with a bag folding machine which produces folded film bags and has a continuous, uninterrupted production cycle. A bag machine of this type is disclosed in our pending patent application Ser. No. 141,127, filed on May 7, 1971, which is assigned to the assignee of the present invention, and is incorporated herein by reference.

The above identified bag folding machine is associated with a high production rate bag making machine, and provides a continuous output of folded and closely interspaced bags at rates as high as 200 per minute. For obvious reasons of efficiency, it is undesirable to interrupt the bag making and folding cycle to package the output of folded bags. At the same time, it will be appreciated that the problem of handling an output of one bag about every 3/10 of a second is substantial.

Bags of the type referred to are packaged in relatively small numbers, sometimes as few as six per carton. At a production rate of 200 bags per minute and a packing charge of six bags per carton, more than 33 packages per minute must be loaded and moved in a continuous cycle. The present invention provides a packaging method and apparatus for continuous operation within these parameters.

SUMMARY OF THE INVENTION

By diverting part of the output of folded bags in each carton charge without interrupting the continuous production cycle, and then recombining the diverted with the non-diverted bags, sufficient time is gained for a rapid loading operation with the bags of another carton charge during the diverting operation. A simplified loading operation is provided wherein one loading stroke simultaneously places an entire carton charge in a carton.

BRIEF DESCRIPTION OF THE DRAWINGS

FIG. 1 is a schematic plan of a known type of bag folding machine incorporating the packaging apparatus of the present invention.

FIG. 1A is a diagrammatic plan showing one mode of bag folding for the FIG. 1 folding machine.

FIG. 2 is an enlarged schematic section taken on lines 2-2 on FIG. 1.

FIG. 2A is a schematic elevation of an adjustable roll mounting bracket assembly indicated by the arrow 2A on FIG. 1.

FIG. 2B is an enlarged schematic elevation indicated by the arrow 2B on FIG. 2.

FIG. 3 is an enlarged schematic perspective of the major operating components shown in FIG. 2.

FIG. 4 is an enlarged schematic perspective of carton handling structure indicated by the arrow 4 on FIG. 2.

FIG. 5 is a fragment of the FIG. 4 structure showing a different operational position.

FIGS. 6-17 are diagrammatic operational views showing the sequential bag handling functions performed by the FIG. 2 apparatus.

FIG. 18 is a schematic control diagram.

DESCRIPTION OF THE PREFERRED EMBODIMENT

FIG. 1 discloses the bag folding machine 20 of our previously identified patent application, the detailed construction of which is not critical to the present disclosure, and the packaging apparatus 22 of the present invention operating in cooperation with the bag folding machine 20.

The bag folding machine 20 may be operatively associated with various types of known bag making machines that heat seal and sever a film web, either to produce the side-weld type of bag or the bottom seal type of bag and to discharge the bags in one, two or three output lanes. In the present disclosure, the bag construction is immaterial, but the illustrated bag folding machine is assumed to receive a dual lane input of bags B illustrated at the left ends of FIGS. 1 and 1A in input LANE A and input LANE C. The bag folding machine 20 is capable of carrying out various folding operations, as disclosed in the above identified patent application, but in the present case is assumed to fold each bag B four times, in the manner next explained.

The bag folding machine 20 (FIG. 1) comprises a primary folder PF and a secondary folder SF, each including various rollers and narrow conveying belts for transporting the bags past folding stations PF1 and PF2 of the primary folder PF, and then at right angles relative to their former direction of movement past folding stations SF1, SF2, SF3 and SF4 of the secondary folder SF. At the folding station PF1 (FIG. 1A) jets of air from an air tube A1 force the transverse central portion of the bags downward through nip rolls indicated generally at PF1 (FIG. 1). This causes the bags to be transversely folded in half, as indicated by the folded bags B1 in FIG. 1A. The bags B1 then pass under a second air tube A2 at the folding station PF2 and the central transverse portion of the once folded bags are forced downward through nip rolls indicated generally at PF2 (FIG. 1) and a second transverse fold is effected so that the bags B2 (FIG. 1A) are one-fourth their former length measured along the conveying path.

The bags B2 proceed to the secondary folder SF and briefly stop under air tubes A3 and A5 where jets of air force the bags downward into nip rolls at the folding stations SF1 and SF3, and fold each bag in half along a transverse line perpendicular to the previous folds. Conveyed now in a single lane toward the folding station SF4 and under an air tube A6, the bags B3 are once more folded in half, the resulting four-times folded bags B4 being ready for stacking and packaging. The present invention concerns the packaging apparatus 22, and the packaging method carried out by the packaging apparatus.

Some indication of the scope of the problems inherent in packaging the bags B4 may be realized from the continuous production rate at which the bag folding machine operates. With the two lane input, single lane output mode above outlined, each lane of the primary folder PF can produce an input to the secondary folder SF of 100 bags per minute. Since the two input lanes are combined for a single lane output, the production rate for the bags B4 is 200 per minute. Further, the type of bags here considered are large, heavy gauge trash can liners which may be packaged as few as six per carton. It is evident, therefore, that unless the continuous production cycle is interrupted, loaded cartons must be

produced at the rate of 33 1/2 cartons per minute, or more than one carton every 2 seconds. A further consideration is that both the bag making machine and the bag folding machine operate best when run continuously, not to mention the undesirable significant drop in production rate if the cycle is interrupted. The packaging apparatus 22 allows the uninterrupted production of folded bags from the bag folding machine 20 at 200 bags per minute, and automatically packages this output in cartons containing as few as six bags per carton.

Before proceeding with a detailed structural description of the packaging apparatus 22, it should be noted that the last folding operation at the folding station SF4 is in the present embodiment conveniently combined with the packaging apparatus. In applications to other folding machines, the folding station SF4 may be considered a part of the packaging apparatus. However, the packaging method and the carton loading structure, alone, have broader applications, and are useful in many other environments where stacks of thin, flexible articles are to be packaged, for example, paper napkins, separator sheets for patty making machines, and so forth.

With reference now to FIGS. 1 and 2, the folded bags are discharged from the secondary folder SF of the bag folding machine 20 on the upper flight of a belt-type main conveyor 24 which comprises a plurality of round-section elastic belts 26 trained around a grooved idler roller, not shown, in the bag folding machine, and around a grooved driven nip roll 28. The nip roll 28 is mounted between side plates 30 and 32 that are cantilevered from the primary folder PF.

If the packaging apparatus 22 is used as a separate machine instead of a built in unit, the side plates 30 and 32 can extend up to the discharge end of the machine with which it cooperates, such as the plate 34 in FIG. 2 which in the present instance is the side plate of the primary folder PF. The idler roller for the belt conveyor 24 is then mounted between the side plates 30 and 32. In either case, the drive train for the packaging apparatus 22 can be taken from the parent machine, as indicated by the chain and sprocket drive train 36 which originates at a right-angle gear box 38 of the secondary folder SF. The gear box is driven by a shaft 40, and operates in timed relation with the bag folding operations carried out in the secondary folder.

A jackshaft 42 extends through the side plates 30 and 32 and is driven by the drive train 36 to power a chain and sprocket drive train connection 44 to the nip roll 28 to deliver the folded bags to the folding station SF4. Cooperating with the nip roll 28 is a nip roll 46. The mounting shafts 48 and 50 (FIG. 1) of the nip rolls extend through the side plate 32 and carry intermeshing gears 52 so that the nip rolls counterrotate. Both nip rolls are jacketed with resilient sleeves to provide optimum frictional contact with the film bags, and are manufactured to close tolerances to provide a uniform nip pressure. It is preferable to mount each end of the downstream nip roll 46 in the manner shown in FIG. 2A. The shaft 50 extends through clearance apertures in the side plates 30 and 32 and is held at each end portion in a pivot bracket 52 pivoted at 54 to one of the frame plates 30 or 32. A compression spring 56 biases the upper end of the pivot bracket against an axially adjustable stop bolt 58, the adjusted position of which regulates the clearance between the fixed nip roll 28

and the movable nip roll 46 so that the nip clearance can be preset. A further advantage is that the resilient mounting will accommodate material variations in bag thickness, such as may be caused by entrapped air.

The air tube A6 (FIGS. 2 and 2B) is mounted directly over the nip of the nip rolls 28 and 46 to direct downward jets of air across the central portion of a bag supported by the main conveyor 24 and an overrun conveyor 60 which supports that portion of the bag which overruns the nip rolls, and which is formed of round elastic belts 62 trained around grooved resilient rolls 64 and 66. As best shown in FIG. 3, the roll 66 is driven by a chain and sprocket drive 68 to the nip roll mounting shaft 48, and to a shaft 70 which carries the roll 66.

For initiating the air blast in the air tube A6 (FIGS. 2 and 2B) which forces the bag to buckle downward into the nip rolls, a retro-reflective sensor S8 is mounted upstream of the nip rolls above the upper flight of the main conveyor 24 to sense the trailing edge of a bag approaching a longitudinally centered position over the nip rolls. The sensor S8 is clamped to a post 80 that is adjustable in the direction of bag movement on a rail 82. Rail 82 is secured to the underside of an air manifold 84 which supplies pressure regulated air for the air tube, as controlled by a solenoid operated valve V8 which is actuated under control of the sensor S8.

As shown in FIG. 2B, the air tube A6 has closed ends and includes a tubular yoke 86 for distributing air to the end portions of the air tube, and a central flexible hose 88 which is connected to the valve V8. A clamp block 90 grips each end portion of the yoke and is secured to a vertically adjustable bolt 92 so that the air tube is both vertically adjustable and can be swung about the axis of the yoke 86 to direct the air blast from the most effective location relative to the nip rolls.

When the air tube A6 (FIGS. 2 and 3) forces a bag into the nip rolls 28 and 46, as later described in detail, the bag can follow an automatically selected one of two paths, according to the operational position of a pivotable, power actuated diverting gate 98. The gate 98 is substantially coextensive with the nip rolls and is formed of a planar panel having an angularly disposed return lip 100. If the gate is in the solid line position shown in FIG. 2, the lip 100 directs the leading edge of a bag descending from the nip rolls rearward onto the upper flight of a diverting conveyor 102.

If the diverting gate is in the phantom outline position, the bag will be directed forward onto the upper flight of a discharge conveyor 104. As best shown in FIG. 3, the diverting gate 98 is mounted on a pivot rod 106 that is coupled by a link 108 to a double-acting air cylinder 110. A solenoid operated valve V9 controls the air supply to the air cylinder 110.

With reference to FIGS. 2 and 3, the diverting conveyor 102 includes a grooved idler roll 112, a driven roll 114 and a plurality of elastic round section belts 116. The rolls are respectively mounted on idler and drive shafts 118 and 120. A gear 122 on the drive shaft 120 is meshed with the output gear 124 on the output shaft 125 of a variable speed cone pulley transmission 126 so that the linear velocity of the diverting conveyor belts 116 can be adjusted. For this purpose, the transmission 126 includes oppositely oriented input and output cone pulleys 128 and 130, interconnected by a drive belt 132 that is trained over a pulley 133 which can be set in a selected position across the faces of the pul-

leys to reposition the belt. Primary drive for the transmission is by means of a chain and sprocket connection 134 between the jackshaft 42 and an input shaft 136 for the cone pulley 128.

The transmission output shaft 125 also carries a chain and sprocket drive connection 138 to a drive-shaft 140 for a grooved drive roll 142 of the discharge conveyor 104. Elastic belts 144 are trained around the drive roll 142 and an idler roll 146 on an idler shaft 148. It will be noted that the described drive trains cause the upper flight of the diverting conveyor 102 to travel rearward and the upper flight of the discharge conveyor 104 to travel forward in synchronism. The respective drive ratios to the conveyors from the variable speed transmission 126 provide the same linear velocity for the belts of each conveyor.

It will be recalled that the diverting gate 98, in the position shown, directs selected bags rearward on the upper flight of the diverting conveyor 102. At the idler roll 112, the diverted bags are gripped against the roll by a gripping conveyor 150 so as to follow around the roller 112 and be deposited on the discharge conveyor 104. Thus, the gripping conveyor 150 includes three grooved idler rolls 152, and a plurality of elastic belts 154 which are tensioned over non-grooved portions of the idler roll 112. Frictional contact of the belts 154 with the idler roll 112, or with a bag therebetween, drives the belts 154.

As thus far described, it is apparent that all bags folded at the nip rolls 28 and 46 will eventually be ejected over the drive roll 142 of the discharge conveyor 104, but that some bags are first diverted rearward onto the opposite end of the discharge conveyor. By thus diverting selected bags, and recombining the diverted bags with the flow of non-diverted bags, the continuous production rate of 200 incoming bags per minute on the main conveyor 24 does not have to be interrupted in order for the packaging apparatus 22 to package that output in groups as few as six bags per carton.

As the bags are ejected from the discharge conveyor 104, they pass under a corrugating roller assembly 160 which includes discs 162 vertically aligned with each of the belts 144. Between adjacent belts 144, a large section O-ring 164 is mounted on the drive roll 142. The O-rings force the bags to assume a wavy or serpentine end profile, so that each bag is temporarily corrugated to lend it beam strength which resists windage as the bag is projected into a stacking tray 170.

The stacking tray 170 includes a short upright wall 172 at its filling end, and side walls 174 and a rear wall 176 that project upward from an apertured base wall or bag loading plate 178. The aperture 180 therein extends nearly to each side wall 174 and is centrally located relative to the front wall 172 and the rear wall 176. Depending from the loading plate 178 and forming an extension of the aperture 180 is a guide chute or discharge throat 182 having vertical walls and adapted to direct a carton-charge of folded bags into a subposed carton C.

According to the method aspect of the present invention, the bag stack accumulated in the stacking tray 170, FIGS. 15 and 16, is transferred into the carton C by what is most aptly described as "plunge-loading." This includes the rapid application of a downwardly applied force having substantially line contact with the uppermost bag of the stack along a line approximately

coincident with a vertical plane bisecting the narrow dimension of the aperture 180. This force causes the bag stack to buckle upward into U-shape at the sides of the line of force application, simultaneous with a downward movement of the base of the U-shaped stack into and through the discharge throat 182, and into the subposed carton C. It will be noted that the front and rear walls 172 and 176 of the stacking tray are slotted. The slots release air which would otherwise be largely retained in the stack and interfere with the loading operation.

For carrying out the loading method above outlined, a bladelike plunger 186 is mounted on the piston rod 188 of a double-acting air cylinder 190 for vertical movement through the aperture 180, the discharge throat 182, and into the carton C. The air cylinder 190 is mounted on a tube 192 which guides the piston rod and extends through an air manifold 194 that supplies pressure regulated air to the air cylinder 190, as controlled by a solenoid operated valve V10.

For automatically feeding empty cartons C (FIGS. 2 and 4) to carton loading position, and for discharging the filled cartons to a closing machine or some other type of handling operation, the packaging apparatus 22 includes a carton conveyor 198 having an input conveyor belt 200 and an output conveyor belt 202, mounted in a fabricated frame 204 which includes support legs 206 (FIGS. 2) for the frame plates 30 and 32. Both belts are driven by a common motor M, by means including a cog belt drive 208 that powers a driveshaft 210. To provide opposite directional movement of the belts, the driveshaft 210 is provided with a pair of reversing gears at 212 for driving the driveshaft 214 of the output conveyor belt 202. The upper flights of both belts slide across a top slide plate 216. The belts 200 and 202 are respectively straddled by upper and lower pairs of carton guide rods 218 and 220, supported by posts 224 secured to the slide plate 216. The uppermost guide rod nearest the secondary folder SF supports a camming rod 226 diagonally across the path of the top closure panel 228 of each carton C to fold the panel into full open position behind the discharge throat 182 (FIG. 2).

It will be noted that the guide rods 218 and two of the guide rods 220 end short of the other guide rods adjacent the reversing gears 212. This is to allow a free path for reciprocating movement of an S-shaped pusher plate 230 which provides means to stop an incoming carton C in loading position, means for transferring the carton after loading from the input conveyor belt 200 onto the output conveyor belt 202, and simultaneously with the transfer step, arrest the next incoming empty carton on the conveyor belt 200 until the pusher plate is retracted to its initial position. Thus, the pusher plate 230 is secured to the piston rod 231 of a double-acting air cylinder 232 controlled by a solenoid actuated air valve V11. One side of the pusher plate 230 has a panel 234 which arrests an incoming carton in loading position when the pusher plate is extended as shown in FIG. 5. The other side of the pusher plate has a panel 236 which arrests the loaded carton in transfer position when the pusher plate is retracted as shown in FIG. 4. Intermediate the panels 234 and 236, the pusher plate 230 has coextensive contact with the side of a carton contacting the panel 234 during transfer of a loaded carton from the input conveyor belt 200 to the output conveyor belt 202.

In operation, the carton conveyor 198 is supplied with erected empty cartons C placed on the input conveyor belt 200 with the top closure panel 228 in position to be intercepted and folded back about its connecting fold line to the body of the carton by the camming rod 226. The carton conveyor pusher plate 230 is positioned as shown in FIG. 5, and the carton is conveyed against the panel 234 and arrested thereby in vertical alignment with the stacking tray discharge throat 182 (FIG. 2) and ready to receive one stack of bags. After the plunger 186 (FIG. 2) descends and loads one bag stack from the stacking tray 170 into the carton, (at the loading station indicated in FIGS. 4 and 5 at 238) the pusher plate 230 is retracted to its FIG. 4 position and the loaded carton moves downstream into contact with the panel 236. The next forward movement of the pusher plate 230 thus transfers the loaded carton onto the output conveyor belt 202 and arrests an empty carton at the loading station 238. FIGS. 6-17 illustrate the steps in accumulating one bag stack (FIGS. 6-14), the carton loading operation (FIGS. 15 and 16), and the loaded carton ejecting operation as the next stack is accumulated (FIG. 17).

The operating sequences in FIGS. 6-17 are next described without reference to the details of the control diagram FIG. 18. It is assumed that an empty carton C has been delivered to the loading position by the input conveyor belt 200, and that the bag count will be 10 per stack, with no previous loading operations having occurred. The bags forming the first stack are identified by numerals 1-10 in the order at which they arrive at the air tube A6 for diversion into the nip rolls. The bags destined for the second stack (FIGS. 13-17) are identified by letters A to E, inclusive.

Bag number 1 (FIG. 6) was, just prior to the position shown, lying flat on the main conveyor 24 and on the overrun conveyor 60, and the trailing edge of the bag had previously been sensed by the retro-reflective sensor S8 (FIG. 2). The sensor S8 is arranged to trigger an air blast from the air tube A6 when the central portion of the bag overlies the nip of the nip rolls, thus pinching the bag and conveying it downward past the gate 98. Gate 98 is at this time in a position to divert number 1 bag rearward onto the diverting conveyor 102. Meanwhile, number 2 bag is closely following on the main conveyor 24.

In FIG. 7, number 2 bag has been diverted in the same manner as the number 1 bag, with number 3 bag closely following and number 1 bag now passing under the gripping conveyor 150 toward the discharge conveyor 104.

In FIGS. 8 and 9, number 3 bag has been diverted onto the diverting conveyor 102, and number 4 bag will be similarly diverted, because the gate 98 is still in its initial diverting position. After bag 4 arrives on the diverting conveyor 102, the gate 98 will be switched to its FIG. 10 position. It will be seen that number 1 bag is on the discharge conveyor 104 in FIG. 9, but is about to be discharged under the corrugating roller assembly 160 into the stacking tray 170. It is significant to observe that the spacing between bags number 1 and 2 (FIG. 6) and indicated by the dimension x , increases to dimension y (FIG. 7) because of the folding operation performed by the nip rolls. This space, and similar spaces between other bags, is later used to combine or interdigitate succeeding bags that are not diverted with the diverted bags 1-4.

FIG. 10 shows that diverted bag 1 has been projected into the stacking tray 170 from the discharge conveyor 104, and that bag 2 is about to enter the stacking tray. Meanwhile, the gate 98 has been repositioned so that number 5 bag, instead of being routed onto the diverting conveyor 102, is being directed onto the discharge conveyor 104 between bags 2 and 3.

While the above outlined functions are taking place, and indeed, throughout any production run, the bags are continuously moving. At the specified production rate of 200 bags per minute, one bag arrives at the nip rollers every $3/10$ of a second. By diverting some of the first incoming bags — here shown as the first four bags — the stacking tray is unobstructed long enough for the plunger 186 to load the carton C and be retracted out of the way for the first bag of the next stack. The loading operation occurs and is explained later, but at this point bags 6-10 remain to be transferred into the stacking tray 170.

In FIG. 11, bag 5 is settling in the loading tray above bags 1 and 2, while bag 6 is being directed onto the discharge conveyor 104 between bags 3 and 4. Similarly, FIG. 12 shows bag 4 settling in the stacking tray above previously stacked bags 1, 2, 5, 3 and 6. Bag 7 is being directed into the space behind bag 4, the last bag which was diverted around the diverting conveyor 102.

In FIG. 13, bag 7 is settling on the stack, and is being followed by bags 8 and 9. Bag 10 also follows the non-diversion path, as shown in FIG. 14, while bag A of the next stack of bags follows bag 10. Shortly after the time of the operational position shown in FIG. 14, bags 9 and 10 have settled on the stack of bags in the stacking tray 170, so that the final order of bags from bottom to top of the completed stack is 1, 2, 5, 3, 6, 4, 7, 8, 9, 10.

Bag A, FIG. 15, of the next stack of bags corresponds to bag number 1 of the stack just assembled, and the gate 98 repositions in time to divert bag A onto the diverting conveyor 102. Meanwhile, the plunger 186 is descending to buckle the first stack of bags into the discharge throat 182 of the stacking tray 170, and by the time bag A, FIG. 16, arrives on the discharge conveyor 104, the first stack of bags has been fully seated in the carton C.

As shown in FIG. 17, before the bag A has been ejected from the discharge conveyor 104, the plunger 186 has retracted to clear the stacking tray 170, and the powered pusher plate 130 has transferred the loaded carton C onto the output conveyor belt 202. An empty carton C1 has been moved to loading position by the input conveyor belt 200, and the previously described bag diverting, bag combining and carton loading cycle repeats in the same manner above described.

At this point it should be noted that the diverting of the first four incoming bags is not a limitation of the carton loading apparatus, but is merely illustrative of the manner in which time for the loading operation can be obtained without interrupting the continuous and high speed flow of bags. In some installations, as controlled by the bag production rate, the size of the bags, and other variables such as the length of the diverting conveyor 102, it may be possible to load a carton with only two or three bags initially diverted, or it may be necessary to divert more than four bags. In any case, the time available for the carton loading operation is equal to the time required for bag A, FIG. 17, to reach its illustrated stack entry position via the long conveying path around the diverting conveyor 102, less the

time required for bag 10 of the preceding count to become settled on the stack.

FIG. 18 is a control diagram for automatically effecting the sequence of operations above described, including the functions of controlling the overall count, the number of bags to be diverted, timing of the plunger 186, and so forth. Since the control system can be effected in different ways with well known and conventional apparatus, once the operating principles are known, FIG. 18 is simplified to merely disclose the general control functions, including:

1. Providing a zero stacking rate for a short period after the first incoming bag is diverted.

2. Doubling the stacking rate when the non-diverted incoming bags are recombined with the diverted bags.

3. Equalizing the stacking rate with the bag input rate after the diverted bags have been stacked.

Electrical power input lines L1 and L2 energize an adjustable counter 250, line 252, which is arranged to start a counting operation when the sensor S8, line 254, sends a control signal or pulse upon sensing the trailing edge of the incoming first bag as mentioned in connection with FIG. 2. Upon receiving this signal, the counter 250 begins two separate counting operations at each pulse from the sensor S8, one which governs the number of bags to be diverted, and another which determines the total count for one stack. Both of these operations are separately adjustable, the diverting operation by a control knob 256, and the total count by a control knob 258. Upon delivery of the last of the diverted bags past the gate 98, FIG. 10, (bag 4 as indicated by the control knob 256) diverted contacts 260, line 262, are closed by a signal from the counter 250, and the solenoid operated air valve V9 (see also FIG. 3) is energized to switch the gate 98 from its former diverting position.

The total count of ten bags, as indicated by the control knob 258 initiates a control pulse to close contacts 264, line 266, and energize a time delay relay TD1. After a delay period to allow the last bag to settle on the stack, timed contacts TD1, line 268, close to energize solenoid operated air valves V10 and V11. The latter valves respectively control the plunger cylinder 190 (FIG. 2) and the pusher plate 230, and when energized cause the plunger 186 and the carton pusher 230 to respectively load the stack into a carton, and to transfer a previously loaded carton onto the output conveyor belt 202. It will be evident that various relays, contacts and other control elements, not shown, are used in an actual control installation to provide repetitive cycling of the described operating sequence, and for the usually required safety interlocks to prevent mechanical damage in the event of malfunction, and to provide interruption of the bag machine 20 in the case of a jam. It is also convenient, for timing purposes, to provide means, such as a control knob 270, for adjusting the duration of the cycle for the plunger 186 to effect the loading operation.

If the control knob 256 is set to divert the first three incoming interdigitated bags the final order of the bags in the stack is 1, 4, 2, 5, 3, 6, 7, 8, etc. to the total count indicated by the control knob 258. If two bags are diverted, the stacking order is 3, 1, 4, 2, 5, 6, 7, 8, and so forth to the total count.

Some of the possible variations of the disclosed packaging apparatus should be noted. If the sensor S8 (FIG. 2) is repositioned so that it senses the trailing edge of

a bag whose leading edge is at the nip rolls instead of beyond the rolls, the bag will be conveyed downward without any folding operation. Thus, the folding operation is not essential to the invention, nor is it essential that the bags have any folds at all. Similarly, it will be apparent that the carton packaging apparatus can be used at the discharge end of the primary folder PF, or as previously indicated, can be used as a separate machine cooperatively associated with other types of machines such as a bag making machine that might discharge directly onto the main conveyor 24.

Although the best mode contemplated for carrying out the present invention has been herein shown and described, it will be apparent that modification and variation may be made without departing from what is regarded to be the subject matter of the invention.

What is claimed is:

1. Article packaging apparatus comprising an input conveyor for delivering a file of spaced film bags, a pair of nip rolls adjacent the discharge end of said input conveyor, means for sensing the trailing edge of each bag approaching said nip rolls, an air tube overlying said nip rolls for directing an air blast at a subposed bag, control means governed by said sensing means to discharge an air blast from said air tube and force the bag into said nip rolls, an upstanding movable diverting gate underlying said nip rolls and movable between two positions for selectively diverting each bag passing said nip rolls in one of two directions, power means for moving said gate, counting means controlling said gate for movement between said positions at a predetermined count of bags, a diverting conveyor for receiving one diverted series of bags, a discharge conveyor for receiving the other diverted series of bags, both series of bags being recombined on said discharge conveyor, a stacking tray for receiving the bags ejected from said discharge conveyor, said stacking tray including a bottom wall having a narrow aperture extending the width of the stack, a vertically reciprocable plunger controlled by said counting means and movable through said apertured bottom wall to force the entire stack through the aperture, and means supporting an upwardly open carton below said aperture for receiving the stack.

2. Article packaging apparatus associated with continuously operated means for producing interspaced articles at a rate which allows minimal time for inserting a stack in a carton, comprising means for diverting preselected incoming articles, means for directing other incoming articles into interdigitated relation with the diverted articles to assemble a continuous series of articles, means for assembling the interdigitated series of articles into a stack, and means for loading a previously assembled stack into a carton when the preselected incoming articles are diverted.

3. Apparatus according to claim 2 wherein the stack is assembled at an accumulating zone, and control means governing the diverting means to effect a zero delivery rate of articles to the stack during the period in which the articles are diverted, and a doubled delivery rate after the articles are interdigitated.

4. In an apparatus for packaging a selected number of articles which are accumulated in a stack for insertion in a carton, said apparatus being associated with means for delivering the articles in single file interspaced relation, the improvement in means for accumulating a stack without interrupting the article pro-

duction rate comprising means for moving the articles along a predetermined path, means for diverting selected incoming articles from said path to an adjacent path, means for interdigitating the diverted with the non-diverted articles on said predetermined path, means for accumulating a stack of the interdigitated articles, and means for ejecting the stack from said accumulating means into a carton.

5. Apparatus for assembling and packaging stacks of flat film bags comprising an input conveyor for moving a file of interspaced bags along a predetermined path, a discharge conveyor for directly receiving selected bags from said input conveyor, a diverted conveyor for receiving other selected bags from said input conveyor and depositing the bags on said discharge conveyor with their interspacing increased by the missing bags directly discharged from said input conveyor to said discharge conveyor, a diverter gate at the discharge end of said input conveyor for directing the bags to said diverter conveyor or to said discharge conveyor, the bags delivered directly to said discharge conveyor interdigitating with the bags moved by said diverter conveyor, a stack accumulator at the outlet end of said dis-

charge conveyor for collecting the interdigitated bags from said discharge conveyor, and a stack loader operatively associated with said stack accumulator for directing the accumulated stack into a carton, and control means for loading the stack when subsequent bags for another stack are being received by said diverter conveyor.

6. A method of assembling and packaging articles from a continuous single file output of interspaced articles comprising the steps of moving the file of articles along a predetermined path, diverting selected articles from said path so that the interspacing of certain articles in the file is increased by the absence of the diverted articles, recombining the diverted articles with the file of articles to interdigitate the diverted and non-diverted articles in a different sequence from their delivery sequence, collecting both the diverted and non-diverted articles to form a stack, repeating the steps to form a second stack, and loading the first stack of articles into a container while the selected articles of the second stack are being diverted.

* * * * *

25
30
35
40
45
50
55
60
65

UNITED STATES PATENT OFFICE
CERTIFICATE OF CORRECTION

PATENT NO. : 3,766,701
DATED : October 23, 1973
INVENTOR(S) : ORRIN H. BESSERDICH et al

It is certified that error appears in the above-identified patent and that said Letters Patent are hereby corrected as shown below:

Col. 4, line 15, change "art" to --air--.
Col. 7, line 56, change "wil" to --will--;
Col. 7, line 67, change "bas" to --bags--.
Col. 8, line 46, change "retractd" to --retracted--;
Col. 8, line 47, change "130" to --230--;
Col. 8, line 51, change "rcombining" to --recombining--.
Col. 10, line 23 and 24, delete "subposed bag" and insert
therefor --bag on the nip rolls--;
Col. 10, line 48, after "stack" add --of the articles--.
Col. 12, line 1, change "interdigitaed" to --interdigitated--.

Signed and Sealed this

fifth Day of *August* 1975

[SEAL]

Attest:

RUTH C. MASON
Attesting Officer

C. MARSHALL DANN
Commissioner of Patents and Trademarks