

M. S. CONNER.
TELEPHONE EXCHANGE SYSTEM.

APPLICATION FILED MAY 28, 1904.

2 SHEETS—SHEET 1.

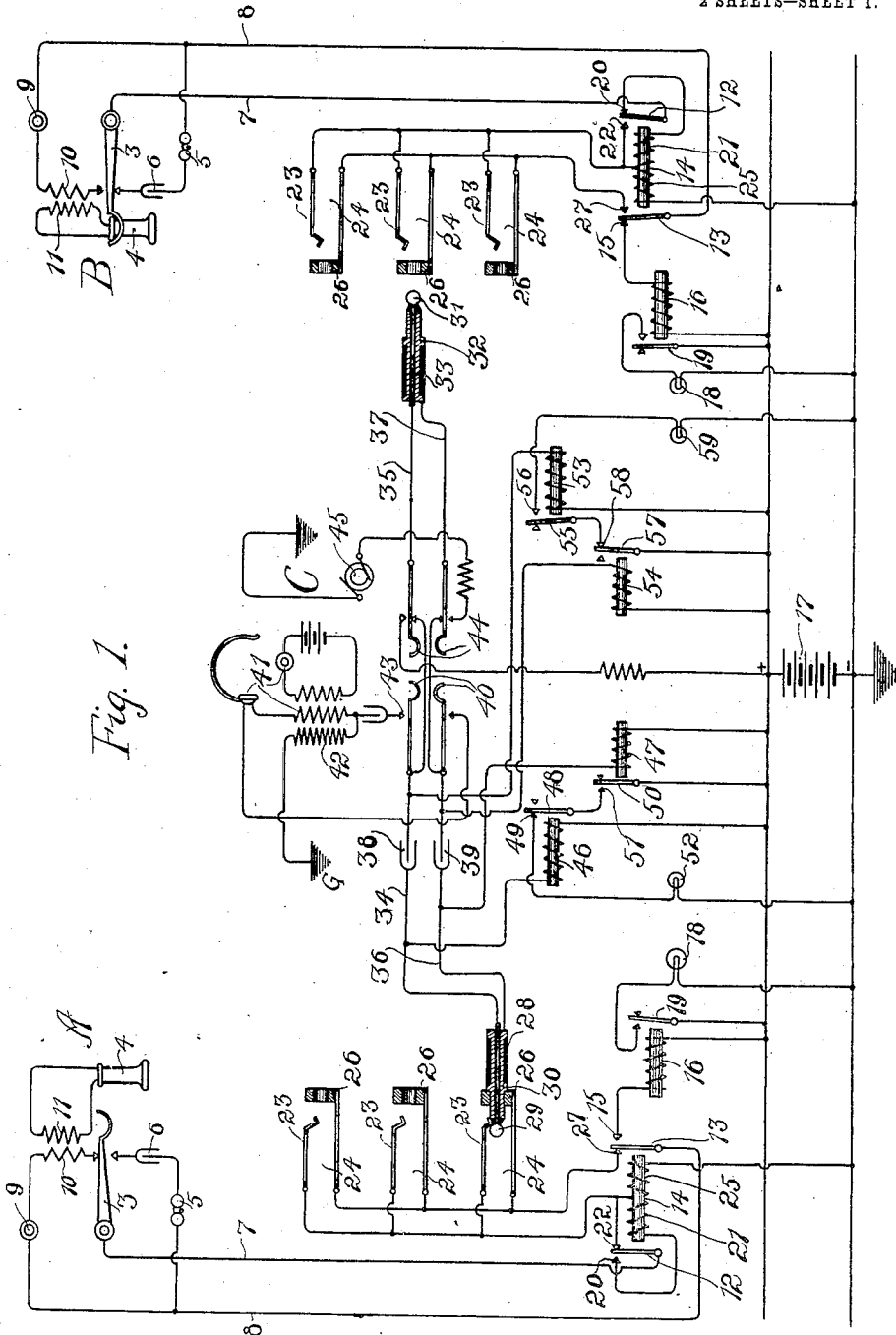

Fig. 1.

Witnesses:

Arthur H. Boettcher,
John Stahl.

Inventor
Merritt S. Conner
By Charles A. Gross
Attorney.

M. S. CONNER.
TELEPHONE EXCHANGE SYSTEM.

APPLICATION FILED MAY 28, 1904.

2 SHEETS—SHEET 2.

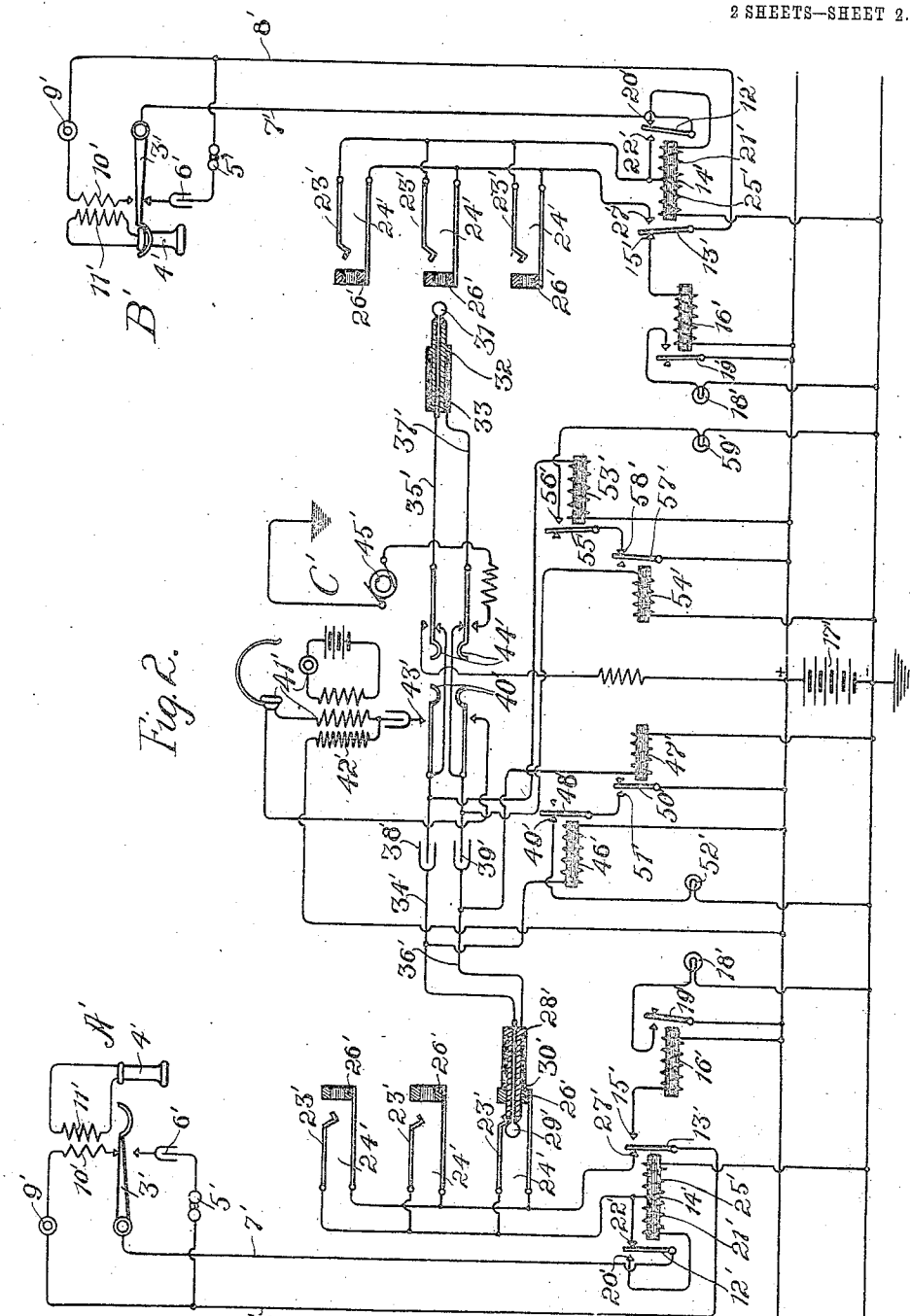

Fig. 2.

Witnesses:

Arthur H. Boettcher,
John Stahr.

Inventor
Merrill S. Conner
By Charles A. Pearce
Attorney.

UNITED STATES PATENT OFFICE.

MERRITT S. CONNER, OF ROCHESTER, NEW YORK, ASSIGNOR TO STROMBERG-CARLSON TELEPHONE MANUFACTURING COMPANY, OF ROCHESTER, NEW YORK, A CORPORATION OF NEW YORK.

TELEPHONE-EXCHANGE SYSTEM.

No. 862,713.

Specification of Letters Patent.

Patented Aug. 6, 1907.

Application filed May 28, 1904. Serial No. 210,224.

To all whom it may concern:

Be it known that I, MERRITT S. CONNER, a citizen of the United States, residing at Rochester, in the county of Monroe and State of New York, have invented a certain new and useful Improvement in Telephone-Exchange Systems, of which the following is a full, clear, concise, and exact description, reference being had to the accompanying drawings, forming a part of this specification.

My invention relates to telephone exchange systems, and in an exchange constructed in accordance with the preferred embodiment of my invention a single source of current located at the central office is employed to furnish talking and signaling current for all of the lines associated with the central office.

My invention provides a telephone system of great simplicity, but at the same time a system which is well adapted for use in conjunction with special and auxiliary devices, such as pay stations and party lines.

One of the important features of my invention is that for bimetallic telephone lines a two-wire multiple system may be employed, each springjack having but two contacts, each adapted for connection with a limb of the telephone line, and one of the contacts serving also as a test contact for indicating to the operator whether or not a called line is busy. It is usually necessary in a two-wire system of this character that the line signal controlling apparatus be actuated by currents flowing over one or both of the conductors which are used also to transmit telephonic voice currents.

My invention provides a telephone system in which the test contact of the springjack is normally disconnected from all other parts of the circuit and in which the other contacts of the associated springjacks are normally but indirectly connected with their telephone line.

My invention introduces a further improvement in the telephone art in that a differential cut-off relay is utilized in such a way that it serves admirably as an impedance coil to prevent the short-circuiting of telephonic voice currents and to balance inductively the telephone line.

My invention will be clearly understood by reference to the accompanying drawing, in which—

Figure 1 illustrates diagrammatically a telephone exchange system constructed in accordance with my invention, and in which Fig. 2 illustrates substantially the same line circuit as that shown in Fig. 1, adapted for use in conjunction with a slightly modified cord circuit.

Referring to Fig. 1 I have illustrated at each of the substations A and B a subscriber's common battery telephone set, comprising in each instance a hook

switch 3, which, when in its normal depressed position, due to the weight of the receiver 4, serves to connect the signal bell 5 with its condenser 6 in bridge of the telephone line limbs 7 and 8, and which when relieved of the weight of the receiver serves to connect the transmitter 9 and the primary 10 of an induction coil in bridge of the line limbs, the secondary 11 of the induction coil being connected with the receiver 4. The telephone line limbs 7 and 8 lead to the central station C, where they are connected respectively with the armatures 12 and 13 of a differential cut-off relay 14. The armature 13 normally makes connection with its back contact 15, whereby the line relay 16 is serially included between the positive pole of the common battery 17 and the line limb 8. The line relay 16 controls the local circuit for a line lamp 18 or other signaling device by means of the relay armature 19. The armature 12 normally makes connection with its back contact 20, to which is connected one terminal of the winding 21 of the differential relay 14. The other terminal of this winding is connected with the front contact 22 of the armature 12, with the tip contacts 23, 23 of the multiple springjacks 24, 24, and also with the other winding 25 of the cut-off relay. These two windings, as shown, are preferably serially and differentially connected. Each winding may be wound to approximately 200 ohms resistance. The sleeve contact 26, 26 of the multiple springjacks, which serve also as the test thimbles, are connected directly with the front contact 27 of the cut-off relay armature 13. The operator's cord circuit provides means for inter-connecting two lines for conversation. The answering plug 28 comprises the tip contact 29 and the sleeve contact 30, these contacts being connected with the tip contact 31 and the sleeve contact 32 of the calling plug 33 by means of the sections 34, 35 of the tip strand and the sections 36 and 37 of the sleeve strand, these sections being conductively insulated by means of the serially connected condensers 38 and 39, the condensers serving in the well known manner to transmit the telephonic voice currents from one line to another. The listening key 40 serves to connect the operator's telephone set 41 in bridge of the cord strands, the induction coil of this set being provided with a tertiary winding 42 connected between the contact 43 and the ground G, the negative pole of the common battery 17 being connected also with the ground. The ringing key 44 serves to connect the source of alternating or pulsating ringing current 45 with the called line. The supervisory controlling relay 46 is connected between the section 34 of the tip strand and the positive pole of the battery, while the supervisory relay 47 is connected between section 36 of the sleeve strand and the same pole of the bat-

tery. The relay 46 is preferably of 1000 ohms resistance, while the resistance of the supervisory relay 47 may be of but 200 ohms resistance. The armature 48, with its front contact 49, and the armature 50, with its back contact 51, jointly control the associated supervisory signal lamp 52. The calling side of the cord circuit is provided in the same manner with the supervisory controlling relay 53 connected between section 35 of the tip strand and the positive pole of the battery, the supervisory relay 54 being connected between the positive pole of the battery and the section 37 of the sleeve strand of the cord circuit. These relays are provided respectively with the armature 55 and its front contact 56 and with the armature 57 and its back contact 58, these armatures and contacts jointly controlling the local circuit for the supervisory signal lamp 59. The supervisory controlling relay 53 may be of 1000 ohms resistance, while the relay 54 is of 200 ohms resistance.

The operation of this embodiment of the system of my invention may be described as follows: The subscriber at substation A, in initiating a call, removes his receiver from the switch hook, thereby closing a circuit which may be traced as follows: from the positive pole of the common battery 17, through the line relay 16, contact 15, armature 13 of the cut-off relay, line limb 8, thence through the transmitter and primary induction coil winding at substation A, and thence by means of the switch hook 3 to line limb 7, this limb of the line leading to the armature 12 of the cut-off relay, and thence normally through the back contact 20, the serially connected windings 21 and 25 of the differential cut-off relay 14 to the grounded negative pole of the common battery. Current flowing through this circuit will not cause a net energization of the cut-off relay on account of the differential relation of its coils, each tending to neutralize the effect of the other. The line relay will be energized, however, thereupon causing the attraction of its armature and the closure of a local circuit through the line signal 18. The illumination of this lamp indicates to the central office operator that a connection is desired and the signal is thereupon answered by the insertion of the answering plug 28 into the answering springjack 24 associated with the line to substation A. Upon the insertion of this plug the following circuit is closed: from the positive pole of the battery through the supervisory controlling relay 46, and thence to the tip contact 23 of the springjack which leads through the winding 25 of the differential cut-off relay to the negative pole of the battery. This circuit of decreased resistance through the winding 25 serves to permit an excess of current to flow therethrough, thereby unbalancing the effect of the relay winding 21 and causing a net energization which serves to actuate the armatures 12 and 13, withdrawing each from its back contact and causing connections to be made with the front contacts, as shown. It will be noted that this energization of the cut-off relay serves to break the circuit through the line relay, whereupon the latter is deenergized to permit the retraction of its armature 19 and the consequent extinguishment of the line signal 18. The actuation of the armature 13 serves also to connect the sleeve contacts of the springjacks directly with the line limb 8. The attraction of the armature 12 from its back contact 20 serves to interrupt the cur-

rent flowing through the differential winding 21 of the cut-off relay.

My invention provides a distinct improvement over certain circuits of the prior art in that one winding of the cut-off relay is not shortcircuited upon the attraction of the associated armature, such a short-circuiting of a winding of a differential cut-off relay causing a material reduction in the impedance of the other winding, which might otherwise be used to choke the flow of voice current and to balance inductively the line circuit.

The connection which is established between the armature 12 and the front contact 22 serves to connect the tip contacts 23 of the multiple springjacks directly with the line limb 7. Upon the insertion of the answering plug into a jack of a calling line the circuit is closed from the positive pole of the battery through the supervisory relay 47, the section 36 of the sleeve strand, contacts 30 and 26, front contact 27, armature 13, line limb 8, the substation transmitter and primary winding of the induction coil, the switch hook 3, line limb 7, armature 12, contact 22, winding 25 of the cut-off relay and thus back to the negative pole of the battery. Current flowing through this circuit causes an energization of the supervisory relay 47, whereupon its armature 50 is attracted, thereby breaking the otherwise closed circuit through the associated supervisory signal lamp 52. The operator, after inserting the answering plug, manipulates her listening key to connect her telephone set with that of the calling subscriber, whereupon she ascertains the number of the line with which connection is desired. Learning that the line leading to substation B is called for, she first applies the testing tip contact 31 of the calling plug to the test thimble of a multiple jack associated with the line to substation A. If this line is not in use, the differential cut-off relay armatures will be in their normal position, as shown, and the test contacts of the springjacks will be disconnected from all other parts of the apparatus. No current will therefore be caused to flow through the tertiary winding 42 of the operator's telephone set and no click will be produced in the operator's ear. If, however, the line to substation B is busy, a plug will have been inserted in one of the multiple springjacks associated with this line and the associated cut-off relay will have been actuated. When, therefore, the operator applies the testing tip contact 31 of her calling plug to a multiple springjack of the line, a circuit will be closed as follows: from the grounded negative pole of the common battery through the tertiary winding 42 of the operator's induction coil, to the contact 43 of the listening key through section 35 of the tip strand to the contact 31, test thimble 26 of the called line, the sleeve contact of the other cord plug, and a relay of the other cord circuit corresponding with the supervisory relay 47 or with the relay 54, shown in Fig. 1, and thence to the positive pole of the battery 17. Current flowing through this circuit will cause a click in the operator's telephone, indicating to her that the called line is busy. Assuming that this line has been tested and found idle, the operator inserts her calling plug, thereupon closing the following circuit: from the positive pole of the battery, through the supervisory controlling relay 53, section 35 of the tip strand of the cord circuit, tip contact 31, tip spring

23 of the multiple jack into which the plug is inserted, winding 25 of the differential cut-off relay and thence to the negative pole of the battery. Current flowing through this circuit causes an energization of the cut-off relay, whereupon its armatures are attracted, at once opening the circuit which might otherwise be closed through the line relay 16 upon the removal of the called subscriber's telephone from its switch hook and serving also to connect the main terminals or contacts of the springjacks directly with the line limbs leading to substation B. The operator then manipulates her ringing key 44 to connect the source of signaling current 45 across the line limbs, whereupon the signal bell at the substation B is actuated to call the subscriber to his telephone. Upon answering the call the subscriber removes his receiver from the switch hook, thereupon closing a conductive path for current and permitting an energization of the supervisory relay 54, whereupon its armature 57 is attracted, breaking connection with the back contact 58 and thereupon causing the extinguishment of the supervisory lamp 59 which will have been illuminated upon the energization of the supervisory controlling relay 53 when the plug is inserted. The extinguishment of this lamp indicates to the operator that the call has been answered by the subscriber at substation B. Either subscriber, upon finishing the conversation, replaces his telephone receiver upon the switch hook, thereby interrupting the path for current through the associated supervisory relay 47 or 54, as the case may be, whereupon the retraction of the respective armature causes the illumination of the associated supervisory lamp to indicate to the operator that the conversation has been completed and that the cord-connecting plugs should be removed from the springjacks. Upon removal of these plugs the apparatus is restored to its normal condition.

In Fig. 2 I have illustrated substantially the same line circuit and have applied to each of the various parts the same reference character as that shown in Fig. 1, except for the addition of the index 1. In the arrangement shown in Fig. 2 the windings of the cut-off relay are preferably of 1,000 ohms resistance each, while the supervisory relays and supervisory controlling relays are then wound to a resistance of 200 ohms each.

A brief explanation of the operation of the circuit shown in Fig. 2 will suffice to make clear this embodiment of my invention. A subscriber at substation A¹, upon removing his telephone from the switch hook, causes an actuation of the line relay, whereupon the line lamp is illuminated, thereby attracting the attention of the operator, who inserts her answering plug, whereupon the following circuit is closed: from the positive pole of the common battery 17¹, through the winding of the supervisory controlling relay 46¹, to the tip contact 29¹ of the answering plug, thence through the tip spring 23¹ of the springjack and through the winding 25¹ of the differential cut-off relay, to the negative pole of the battery. The additional current caused to flow through this winding 25¹ upon the insertion of the answering plug, causes a net energization of the cut-off relay, whereupon its armatures are attracted to open the circuit through the line relay and to connect the main terminals of the springjacks directly with the line limbs. The insertion of the answering plug into a calling line causes the closure of an

additional circuit, which may be traced from the negative pole of the battery through the supervisory relay 47¹ to the section 36¹ of the sleeve strand of the cord circuit, thence through sleeve contacts 30¹ and 26¹ to contact 27¹, the armature 13¹, line limb 8¹, the subscriber's telephone apparatus, line limb 7¹, armature 12¹, contact 22¹, tip spring 23¹, tip contact 29¹, tip strand 34¹, and through the winding of supervisory controlling relay 46¹ to the positive pole of the battery. The energization of the supervisory relay 47¹, due to current flowing through this circuit, causes the attraction of its armature 50¹ to interrupt the otherwise completed circuit through the supervisory lamp signal 52¹. With this explanation of the operation of the supervisory signaling apparatus, the mode of operation of the other parts of the system will be made clear.

In the modification shown in Fig. 2 the tertiary winding of the operator's induction coil should be connected with the positive pole of the battery in order to provide the busy test, as will be readily understood by those skilled in the art. In this modification the current is fed to the subscribers' telephone instruments principally through the supervisory signaling relays. These relays are therefore made of comparatively low resistance.

In the modification shown in Fig. 1 the current is fed to the substation apparatus partly through the supervisory relay of 200 ohms resistance and partly through the 200 ohm winding of the cut-off relay, and in this modification of Fig. 1 it is desirable, therefore, that there be no short-circuited winding upon the cut-off relay, as, for instance, the winding 21, which could cut down the impedance of the coil 25.

While I have herein shown and described a preferred embodiment of my invention, together with a single application relating to the cord circuit to be employed in association therewith, it will be understood by those skilled in the art that many other modifications may be employed without departing from the spirit of my invention. I do not wish, therefore, to limit myself to the precise constructions herein set forth, but

Having described my invention I claim as new and desire to secure by Letters Patent:—

1. In a telephone exchange system, the combination with a telephone line extending by its limbs from a substation to an exchange, of cord-connecting apparatus at the exchange for connecting said line with another for conversation, a cut-off relay having two differential windings normally serially included in a single line, a line signal controlled by switching apparatus at the substation, and means whereby the connection of the cord-connecting apparatus with said line causes an actuation of said relay to destroy the substation control of said line signal and to open the circuit through one of the windings of said cut-off relay.

2. In a telephone exchange system, the combination with a telephone line extending by its limbs from a substation to an exchange, of cord-connecting apparatus at the exchange for connecting said line with another for conversation, a cut-off relay having two differential windings serially included in a single limb of said line, a line signal controlled by switching apparatus at the substation, and means whereby the connection of the cord-connecting apparatus with said line causes an actuation of said relay to destroy the substation control of said line signal and to break the circuit through one of the windings of said cut-off relay.

3. In a telephone exchange system, the combination with a telephone line extending by its limbs from a substation to an exchange, of a source of current at the ex-

change for supplying current to the substation transmitters, cord-connecting apparatus for connecting said line with another for conversation, a cut-off relay having two differential windings normally serially included in an electrical path between one terminal of the source of current and substation apparatus, a line signal normally serially included in circuit with the telephone line, and means whereby the connection of said cord-connecting apparatus with said line causes an actuation of said relay to disconnect said line signal from the telephone line and to open the circuit through one of the windings of said cut-off relay.

4. In a telephone exchange system, the combination with a telephone line extending by its limbs from a substation to an exchange, of cord-connecting apparatus at the exchange for connecting said line with another for conversation, a cut-off relay having two differential windings normally serially included in a single limb of said line, a line signal controlled by switching apparatus at the substation, and means whereby the connection of said cord-connecting apparatus with said line causes the closure of a circuit through a winding of said relay, thereby causing an actuation of said relay to disconnect said line signal from the telephone line and to break the circuit through one of the windings of said differential cut-off relay.

5. In a telephone exchange system, the combination with a telephone line extending by its limbs from a substation to an exchange, of cord-connecting apparatus at the exchange for connecting said line with another for conversation, a cut-off relay having two differential windings serially included in a single limb of said line, a line signal controlled by switching apparatus at the substation, and means whereby the connection of said cord-connecting apparatus with said line causes the closure of a circuit of decreased resistance through a winding of said relay, thereby causing an actuation thereof to destroy the substation control of said line signal and to interrupt the circuit through one of the windings of said cut-off relay.

6. In a telephone exchange system, the combination with a telephone line extending by its limbs from a substation to an exchange, of a source of current at the exchange for supplying current to the substation transmitters, a cut-off relay having two differential windings normally serially included in one of said limbs between one terminal of said source of current and the substation apparatus, a line signal normally serially included in the other of said limbs between the other terminal of said source of current and the substation apparatus, a spring-jack at the exchange having a tip contact permanently connected to the common terminal of said differential relay windings, and a sleeve contact normally disconnected from said line, cord-connecting apparatus associated with said source of current for connecting said line with another for conversation, means whereby the insertion of a plug of said cord connecting apparatus within said jack closes a circuit of decreased resistance through one winding of said differential cut-off relay to cause an actuation thereof, switching means controlled by the actuation of said cut-off relay to open the circuit from a terminal of said source of current through said line signal to one limb of the line and to connect said limb to the sleeve contact of the springjack, and other switching means controlled by the actuation of said cut-off relay to open the circuit of the winding of said cut-off relay connected between the tip contact of the springjack and one limb of the line.

7. In a telephone exchange system, the combination with a telephone line extending by its limbs from a substation to an exchange, of cord connecting apparatus at the exchange for connecting said line with another for conversation, a cut-off relay having two differential windings serially included in the circuit with said line, a spring jack contact at the central exchange normally disconnected from the line at one armature of said relay, another spring jack contact normally connected with a line through part of the relay winding and through another armature thereof, and means upon connection of said connecting apparatus with the spring jack for causing

actuation of said relay whereby the first mentioned contact is connected with the line and the second mentioned contact directly connected with the line.

8. In a telephone exchange system, the combination with a telephone line extending by its limbs from a substation to an exchange, of cord connecting apparatus at the exchange for connecting said line with another for conversation, a cut-off relay having two differential windings normally included serially in the line circuit, switching mechanism controlled by said relay, a spring jack contact at the central exchange normally disconnected from one line limb by said switching mechanism, a second spring jack contact normally connected with the other line limb through said switching mechanism and through part of the relay winding, and means upon connection of said cord connecting apparatus with the spring jack contacts for causing actuation of said relay and switching mechanism whereby the first spring jack contact is connected with the one line limb and the second spring jack contact directly connected with the other line limb.

9. In a telephone exchange system, the combination with a central exchange, of a telephone line extending therefrom, cord connecting apparatus at the exchange, a cut-off relay having two differential windings normally serially included in the line circuit, switching mechanism controlled by said relay, a spring jack contact normally disconnected from one line limb at said switching mechanism, a second spring jack contact normally connected with the other line limb through said switching mechanism and through one of said relay windings, and means upon connection of said cord connecting apparatus with said spring jack contacts for causing energization of said relay and actuation of said switching mechanism whereby said first spring jack contact is connected with the one line limb and the second spring jack contact directly connected with the other line limb and whereby one of said relay windings is entirely disconnected from circuit.

10. In a telephone exchange system, the combination with a central exchange, of a telephone line extending therefrom, cord-connecting apparatus at the central exchange for connecting said line with another, a cut-off relay having two differential windings normally serially connected in one of the line limbs, switching mechanism for said relay, a line signal normally serially included in the other line limb at said switching mechanism, a spring-jack contact normally disconnected from one line limb through part of said switch mechanism, a second spring-jack contact normally connected with the first line limb through another part of said switching mechanism and through one of said differential windings, and means upon connection of said cord connecting apparatus with the spring jack contacts for causing an additional circuit through one of the differential windings whereby said relay becomes energized and its switching mechanism actuated, actuation of said switching mechanism causing disconnection of the line signal from the other line limb, connection therewith of the first spring jack contact and connection of the second spring jack contact directly with the first line limb and exclusion from circuit of the winding through which said second spring jack is normally connected with the first line limb.

11. In a telephone exchange system, the combination with a telephone line extending from a central exchange to a substation, of cord connecting apparatus at the central exchange for connecting said line with another, a cut-off relay having a winding normally entirely included in one limb of the line circuit, said winding being normally balanced to prevent energization of the relay, a spring jack contact normally entirely disconnected from one line limb, a second spring jack contact normally connected with the other line limb through part of the relay winding, and means upon connection of said cord connecting apparatus with said spring jack contacts for causing unbalance of the relay winding, whereby said relay is energized and whereby said spring jack contacts are directly connected with the line limbs.

12. In a telephone exchange system, the combination with a telephone line extending from a substation to an exchange, of a source of current at the exchange, cord con-

necting apparatus at the exchange, a cut off relay having two differential windings serially included in a single line limb of said line, a line signal controlled by switching apparatus at the substation, and means whereby the connection of the cord connecting apparatus with the line causes an actuation of said relay to destroy the substation control of said line signal and to open the circuit through one of said differential windings.

10 13. In a telephone exchange system, the combination with a telephone line extending from a substation to an exchange, of cord connecting apparatus at the exchange, a cut off relay at the exchange having all its windings nor-

mally serially included in one line limb, a line signal circuit controlled by the cut off relay, and means adapted upon connection of the cord connecting apparatus with a line for causing part of the relay winding to be disconnected from circuit and the line signal circuit opened. 15

In witness whereof, I hereunto subscribe my name this 18th day of May A. D., 1904.

MERRITT S. CONNER.

Witnesses:

H. E. BALL,
A. J. MAHAN.