

[54] CLOSURE FOR A PLURALITY OF DIFFERENT SIZED OPENINGS

3,189,072 6/1965 Starr ..... 220/60 R  
3,332,572 7/1967 Green ..... 220/60 R  
3,355,061 11/1967 Ritter ..... 220/60 R

[76] Inventor: Philip D. Bart, 27 Keith Dr., Monsey, N.Y. 10952

[22] Filed: Jan. 26, 1972

[21] Appl. No.: 220,859

Primary Examiner—William I. Price  
Assistant Examiner—Steven M. Pollard  
Attorney, Agent, or Firm—Daniel M. Rosen

[52] U.S. Cl. .... 220/212, 306, 356; 215/228, 319

[51] Int. Cl. .... B65d 43/10

[58] Field of Search ..... 220/60 R, 60 A, 42 A, 69, 220/97 F; 215/41; 46/61, 11

[57] ABSTRACT

A multi function device, adapted to be employed as a closure member for wide diameter containers by virtue of an outer rim and narrow diameter containers by virtue of an inner rim. The cover surface extends upward and can provide a partial vacuum seal. The cover surface is designed for aerodynamic stability and the device can be thrown with a spinning motion for gliding effects. Also, two of the devices can be combined to form a string wound amusement device.

[56] References Cited

UNITED STATES PATENTS

2,629,202	2/1953	Stivers et al. ....	46/61
2,831,613	4/1958	Soffer.....	220/60 R
3,089,605	5/1963	Buonauro .....	220/69
3,096,897	7/1963	Hansen .....	220/60 R

1 Claim, 8 Drawing Figures

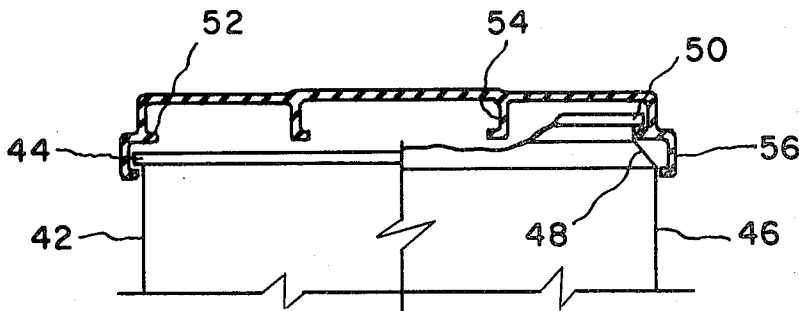

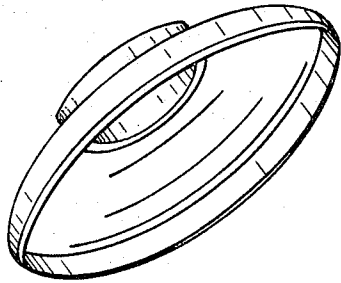

Fig. 1

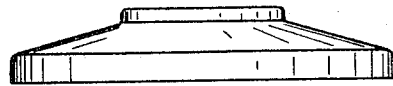

Fig. 2

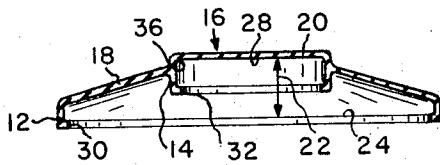

Fig. 3

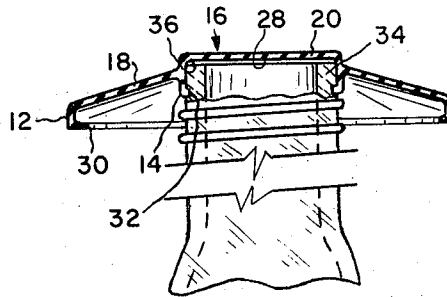

Fig. 4

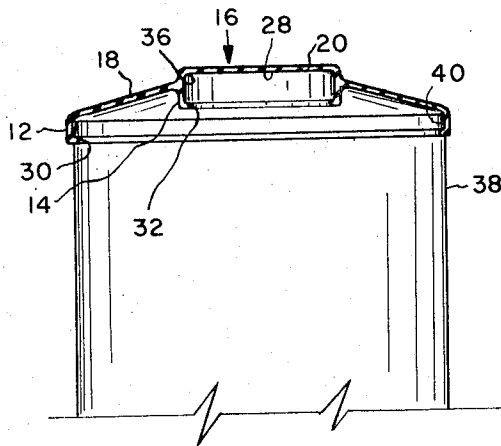

Fig. 5

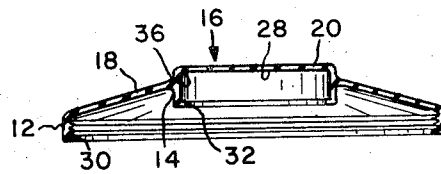

Fig. 6

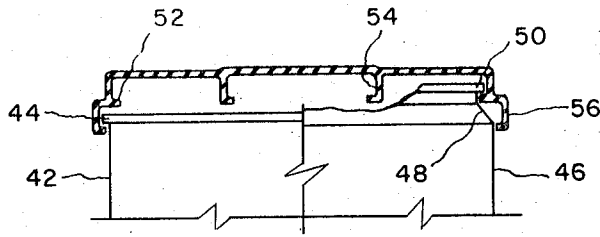

Fig. 7

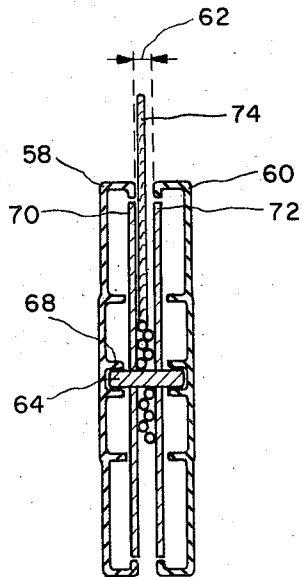

Fig. 8

## CLOSURE FOR A PLURALITY OF DIFFERENT SIZED OPENINGS

This invention relates principally to closure devices, and more specifically to closure devices for a variety of conventional container openings. In addition, the invention relates to a closure device which can have other functions which increase the commercial application of the invention. Particularly, the device of this invention can be employed as a toy, of the type which permits the device to be thrown with a spinning motion such that it will exhibit aerodynamically stable characteristics. Further, the device of the present invention can be combined with a second device to form a string wound amusement device.

Prior art closure devices suffer from the disadvantages of lack of broad scale utility. That is, they were limited to one size of container, such as a bottle, and are difficult to remove without the use of flaps or the like. Further, the newest type of containers, such as the so called "pop-top" or ring tab opened cans, do not provide for convenient closure. Those devices which are adaptable to various diameter containers are invariably cumbersome to use or involve a relatively expensive form of mechanical adjustability, or too bulky to permit stacking, as in cans or the like.

Further, since such prior art devices which are employable as closures often form part of household equipment, it would be desirable for such a device to have broader appeal within a household. One example is to construct the device as a toy or amusement mechanism, since the most common form of overlapping market found in a single consumer or consumer household is both the houseware or convenience appliance market, and the amusement or toy area, particularly where the appeal is to relatively young children.

Accordingly, it is the prime object of the invention to provide a novel multi function device which will have both a household utility and an appeal as an amusement device.

It is a principal object of the invention to provide a novel closure device adaptable for a variety of closure diameters, particularly the most popular size of both bottle and can containers.

It is a further object of the invention to provide a novel closure device adaptable to fit a variety of closure diameters within a firm seal, partially vacuum.

It is still further object of the invention to provide a novel closure device for a wide diameter can type container which will permit stacking.

It is another object of the present invention to provide a novel closure device which can be easily and simply manufactured out of one molded unit.

It is still another object of the invention to provide a novel closure device which can also provide amusement.

The foregoing objects are realized by a multi function device formed with a cover portion having an outer rim integrally formed with the cover for engaging a wide diameter container, such as a can, and an inner rim enclosed within the outer rim and integral with the cover for engaging a narrower diameter container, such as a bottle. Each of the rims depend extend downward from the cover, and each is provided with an inwardly extending portion. The downward and inward extension may be generally rounded in integral form as an inwardly directed curved surface. The rims are prefera-

bly concentric, and a third rim may be provided for special container shapes. The cover extends upward, to provide deflection space for creating a partial vacuum seal. Further, the cover is designed for aerodynamic stability so as to provide amusement as a toy capable of aerodynamic flight when thrown with a spinning motion. Also, two such devices can be combined to form a string wound toy.

The foregoing object and brief description, as well as further features, objects and advantages, will become more apparent from the following more detailed description and appended drawings, wherein

FIG. 1 is a perspective view of the novel device of the present invention,

FIG. 2 illustrates a side plan view thereof,

FIG. 3 shows a cross sectional view thereof,

FIG. 4 illustrates a cross sectional view showing the device in accordance with the present invention as affixed to a can type container,

FIG. 5 describes a cross sectional view of the device in accordance with the present invention as affixed to a narrower diameter container such as a bottle,

FIG. 6 an alternative embodiment of the present invention illustrating in sectional view the manner wherein the device is more firmly affixed to a wide diameter container,

FIG. 7 shows an alternative embodiment for a less common form of can type, and

FIG. 8 shows one manner wherein the present invention is employed as an amusement device.

Referring to the Figures, wherein like reference numerals indicate like components, the multi functional device 10 in accordance with the invention is shown. With particular reference to FIGS. 1 through 3, it is seen that the device is constructed with an outer rim 12 and an inner rim 14 formed as part of a cover member 16. The inner and outer rims are each formed so as to depend or extend downwardly, as shown, from the cover member 16. The construction of the device includes a first cover portion 18 into which the outer rim 12 depends, and a second cover portion 20, into which the inner rim 14 depends. The second cover portion surface 20 as shown protrudes through the otherwise continuous surface of cover portion 18.

It will be understood that the second cover portion 20 and the first cover portion 18 may actually be a uniformly continuous surface, however, the construction shown is preferred for reasons which will become more apparent from the following description.

The cover 16 is provided with an elevation 22 relative to the plane defined by a horizontal line 24 connecting the upper part of the outer rim 12. A similar elevation, not shown, can be designed into the second cover portion 20 relative to the plane defined by a horizontal line 28 connecting the upper part of the inner rim 14, however, the cover portion 20 can be flat, or otherwise coincide with the horizontal plane line 28, as is shown.

Surrounding the inner lower edge of the outer rim 12 is an inwardly extending bead or rib portion 30. A similar inwardly extending bead or rib portion 32 is formed on the inner lower edge of the inner rim 14. These beads can be added, but are preferably formed when the entire cover is formed. The rims can blend into the ribs with an inwardly directed continuous radius of curvature, or merely depend from or extend down from

the cover with the inner bead, as shown, extending inwardly orthogonally from the downward portion.

The second cover portion 20 is preferably concentric within the first cover portion 18, both having a common center representing the point of greatest elevation above a common surface beneath.

The device is preferably integrally molded of a suitably resilient or flexible plastic material, such as is well known.

Although not shown, as in FIG. 3, the cover portion 20 can be thicker in cross section than the cover portion 18. The intent is that the cover portion 20 show less resiliency than the portion 18. However, it will be apparent that less resiliency can be achieved by using less resilient material, reinforcement or the like, although the expense of manufacture may be increased by use of the latter techniques. The purpose of a less flexible inner portion will be explained in further detail below.

Referring to FIGS. 4 and 5, the device is shown in cross section installed on a bottle type container and a can type container respectively. In each case, the cover 16 is constructed with an elevation placing the center of the device in the approximate center of the container at the greatest elevation above the top plane of the container. With regard to the bottle connect, the inner rim 14 of the cover member 18 is press fit over the neck of the bottle 34. The inner rim 14 and its associated bead portion 32 will conform to the radius of curvature of the bottle neck exterior and extend therealong. A slight radius of curvature to the inner surface of the rim 14 assures firm contact. Contact between the outer surface of the bottle neck thus occurs at a point 36 and again at a point determined by the bead 32. Tension is maintained by the bead 32 against the natural resiliency of the material of the inner rim 14 and the cover portion 20. The dual contact further provides additional security in contact over that of the normal inner shape of curvature of the inner rim 14 without the bead 32. Also, formation of a slight air space provides some additional insulation value. The large extending edge represented by the cover portion 18 and outer rim 12 provide a convenient lever to facilitate ease of removing the cover from the bottle. In addition, where the cover portion 20 is provided with slight elevation over the horizontal plane of the bottle top, it will be seen that downward pressure applied to the top of the cover portion 20, as by a thumb or like pressure, will result in a partial deformation of the cover portion resulting in slight movement of the bead 32 away from the side of the bottle. As a result of the movement of the bead 32 away from the side of the bottle, removed of the cover member 16 from the bottle is further facilitated.

Referring now to FIG. 5, the cover member 16 is shown affixed to the end of a can type container. The can, illustrated generally as 38, is of a conventional form whereas the sides are linear and terminate in a seamed lip or upper rim 40. It is understood that the opening in the can top be either of the pull-tab variety or of the circumferentially slit opening type. In engagement, the cover member 16 is press fit over the top of the can 38 such that the bead 30 slides past the seam or upper rim 40. The natural resiliency of the cover portion 18 will cause the bead 30 to engage the side wall of the cover 38 in friction engagement, resulting in closure. By applying further closure pressure to the

cover member 16, air is forced out from the interior space between the cover member and the can top. If a sufficiently tight seal has been formed between the outer rim 12 and the bead 30, a partial vacuum is created between the cover member and can top, thereby further increasing the closure pressure.

When it is desired to remove the cover member, pressure is again applied to the cover portion, but now the pressure is applied until partial deformation of the rim 12 is achieved, forcing the bead 30 away from the can side wall. The partial vacuum seal is thus broken, and the cover may be easily removed.

As an alternative, shown in FIG. 6, it is possible to form the bead in the outer rim as a spiral thread for threaded engagement with a threaded can top. Also, if the thread gauge is wide, a threaded top can engage a conventional can top.

In FIG. 7, a further embodiment is illustrated of a cover member which can be employed to secure either a standard linear can or a shoulder can container. For ease of illustration, FIG. 7 shows how the cover can engage with either type. In this embodiment, the cover is shown with a flatter top portion, with much less taper than that of FIG. 2. The flatter cover allows stacking of covered containers to be more easily facilitated. In the first type of container 42 the can side is linear and terminates in a seamed lip upper rim 44, as shown. The second can type 46 employs a shoulder 48 wherein the can side projects slightly inward before terminating in the seamed lip 50 on the upper rim. Since the present invention relies upon a friction fit over the seamed lip, the cover herein employs a third rim 52, preferably concentric with the first and second rims 54 and 56, and positioned as shown therebetween but closer to the outer rim. In position, the cover can be set atop the shouldered type of container with its additional rim 52 fittably mounted over the shouldered can top. The additional outer rim 56 permits the cover to retain its desired shape since the outermost rim can now clear the shoulder portion of the can. The cover can also be fit over the normal or linear side can since the outer rim 56 of the cover remains fully effective for engagement.

As shown in the cross sectional view, the downward and inwardly extending rim portion of the additional rim 52 is constructed as the first and second rims 54 and 56 which are intended to correspond to those shown above in connection with the prior Figures.

In all of the foregoing embodiments the outer surface of the cover is round, as shown in FIG. 1, with a downwardly extending outer rim. Also, each type, that of FIG. 1 and FIG. 7, possesses a slight taper. As a result, the cover can be thrown or hurled with a spinning motion, thereby giving rise to an aerodynamically movable mechanism which will possess a sufficient glide characteristic to be controlled in such flight by angle or toss, degree of spin, degree of toss, etc. By providing the cover device with such aerodynamic characteristics, while retaining its function as a multi container width cover, an additional utility is provided greatly enhancing the desirability of the device.

Referring to FIG. 8, a further utility is shown. In FIG. 8, two of the cover devices can be combined to form an amusement device of the string wound variety. In this embodiment, a single outer rim is shown, and the cover has the flatter top. As shown, a first cover member 58 and second cover member 60 are juxtaposed

with a spacing 62 therebetween. The spacing is fixed by means of an insert 64 which fits into an additional concentric set of rims 66 which may be integrally molded into the innermost rim sets 54 of the respective covers 58 and 60. The insert 64 is preferably of a rigid plastic material and is shaped at either end to correspond to the shape of the insert plug, thereby enabling the cover members 58 and 60 to be frictionally engaged onto the insert 64 in the same manner as the fit of the cover member over the bottle top as described above.

The insert includes facing plates 70 and 72 defining the spacing 62. Between the facing plates and on the insert is wound a string 74. The completed device is then operative as a string wound toy, such as is sometimes referred to as a "yo-yo." Obviously either embodiment, that of FIG. 1 or FIG. 7 or combinations, could be thus employed.

Other variations and uses for this multi function cover can be demonstrated to be within the skill of the art.

Since certain changes and modifications can be readily entered into in the practice of the present invention without departing substantially from its intended spirit or scope, it is to be fully understood that

all of the foregoing description and specification be interpreted and construed as being merely illustrative of the invention and in no sense or manner as being limiting or restrictive thereof.

What is claimed is:

1. A closure member, for use with a plurality of different sized rimmed openings, comprising a cover portion, a first closure portion extending downward from said cover portion and including an inwardly extending rib portion for frictionally engaging one of said rimmed openings, a second closure portion extending downward from said cover portion and including an inwardly extending rib portion for frictionally engaging another sized one of said rimmed openings, said first closure portion being relatively narrower than said second closure portion and concentrically positioned within said second closure portion of said cover portion, and a third closure portion, concentrically positioned relative to said first and second closure portions, extending downwardly from said second closure portion and including an inwardly extending rib portion for frictionally engaging another sized one of said rimmed openings.

\* \* \* \* \*

25

30

35

40

45

50

55

60

65