

Aug. 21, 1962

H. CARMEN

3,049,719

GARMENT WITH FLEXIBLE SLEEVE JOINTS

Filed Jan. 4, 1960

2 Sheets-Sheet 1

Fig. 1

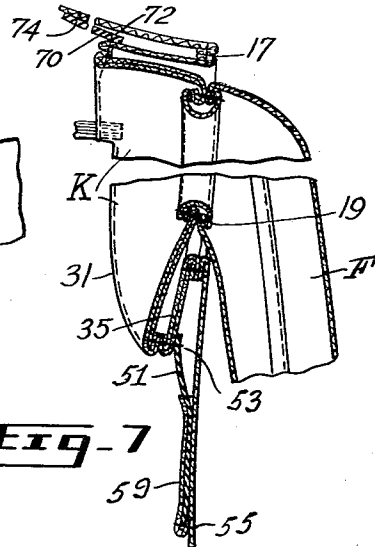
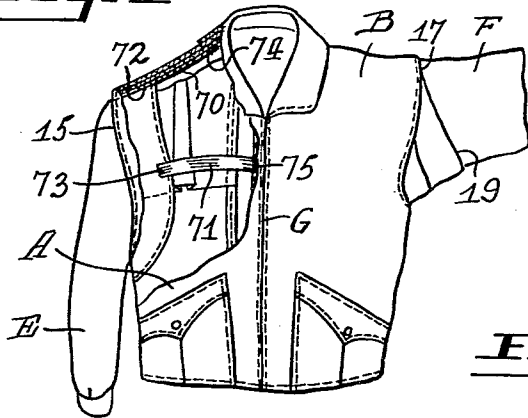

Fig. 7

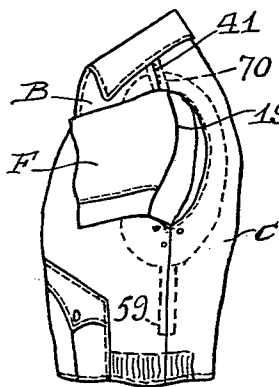

Fig. 2

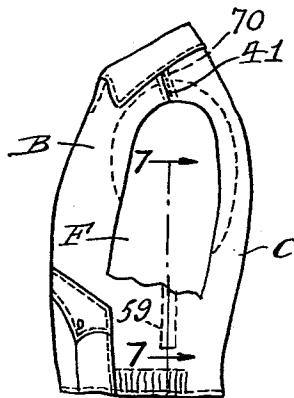

Fig. 3

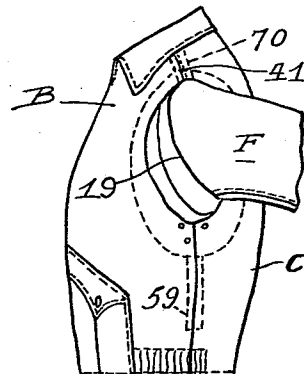

Fig. 4

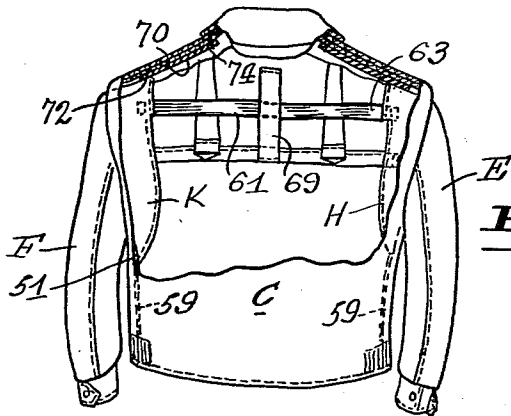

Fig. 5

Inventor
Hyman CARMEN

By *Wm. S. Sweeney*
Attorney

Aug. 21, 1962

H. CARMEN

3,049,719

GARMENT WITH FLEXIBLE SLEEVE JOINTS

Filed Jan. 4, 1960

2 Sheets-Sheet 2

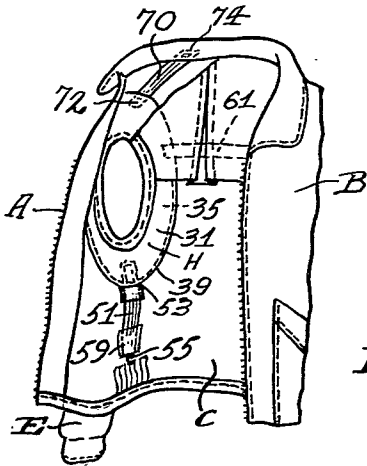

Fig. 6

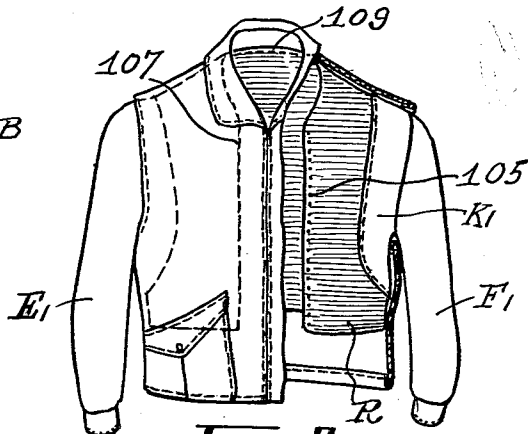

Fig. 8

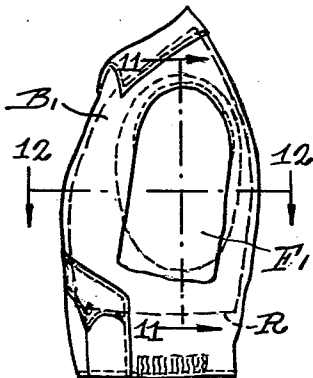

Fig. 10

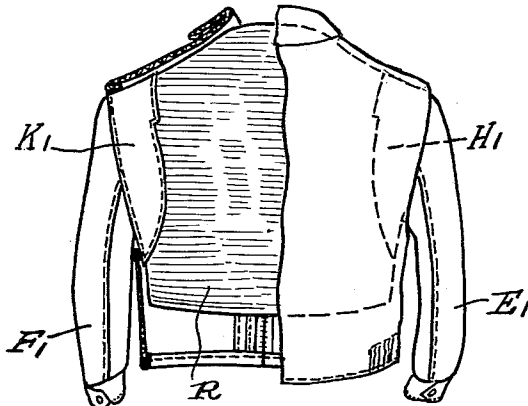

Fig. 9

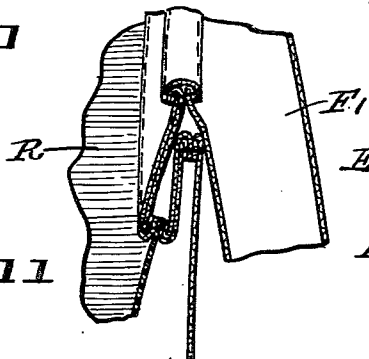

Fig. 11

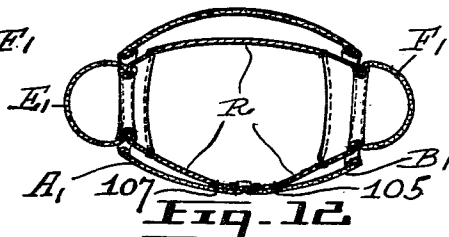

Fig. 12

Inventor
Hyman CARMEN

By *[Signature]*
Attorney

1

3,049,719

GARMENT WITH FLEXIBLE SLEEVE JOINTS

Hyman Carmen, Montreal, Quebec, Canada, assignor to
E. & R. Inc., Montreal, Quebec, Canada

Filed Jan. 4, 1960, Ser. No. 236

3 Claims. (Cl. 2-93)

This invention relates to improvements in upper garments in the nature of jackets and is particularly adaptable for bulky jackets used for sporting and military purposes.

One of the problems with slide-fastened weather resistant jackets is that they tend to bind at the armpits and around the shoulder. An aim of the present invention is to provide a structure which prevents binding even when the garment is heavily insulated or otherwise padded or made from bulky and stiff material.

Applicant's Development

In accordance with the present invention the upper garment is provided with a body portion and sleeves connected to the body. In the case of the invention, however, the sleeve inner margin is not directly connected, in the usual manner, to the armhole margin of the body, but is articulated by an expansible connecting structure entirely round the armhole. This connecting structure includes a bellows-like insert or tuck which is connected at one end to the margin of the armhole and at the other to the inner margin of the sleeve. This insert normally rests within the garment against the body, being held in this position by resilient means anchored to the body. The resilient means permits the insert to be displaced or expand when the arm is moved in any direction. The inner margin of the sleeve is thus allowed to "part company with" the margin of the armhole, but is immediately caused to come back into normal repose position with the margin of the sleeve and the margin of the armhole through the action of the resilient structure.

Having thus generally described the nature of the invention it will be referred to in more detail by reference to the accompanying drawings illustrating preferred garments embodying the invention, and in which

FIGURE 1 is a front elevation partly in section of the garment.

FIGURES 2, 3 and 4 are side elevations of the garment with the sleeve in different positions so as to show its articulation.

FIGURE 5 is a rear view of the garment partly cut away to show the retracting structure.

FIGURE 6 is a front elevation of the garment partially opened to show the internal structure.

FIGURE 7 is an enlarged fragmentary cross-section along the line 7-7 of FIGURE 3.

FIGURE 8 is a front elevation of an alternative form of garment according to the invention, partly cut away to show the internal structure.

FIGURE 9 is a rear view of the garment shown in FIGURE 8 also partly cut away.

FIGURE 10 is a side elevation of the garment shown in FIGURES 8 and 9.

FIGURE 11 is an enlarged fragmentary cross-section along the line 11-11 of FIGURE 10.

FIGURE 12 is a cross-section along the line 12-12 of FIGURE 10.

More specific reference will now be made to the drawings.

The garment which in this case is a weatherproof slide-fastened jacket is made up of a body including a pair of front panels A and B joined at the shoulders and at the side of the garment by stitching to a rear panel C.

The body is provided with armholes having margins 15 and 17 to which the sleeves are connected by the articulat-

2

ing structure as will be described. The sleeves are provided with inner margins of which the left sleeve margin 19 is shown, connected to the articulating structure and thus articulated to the garment as will be more fully described.

The garment is provided with a slide fastener G running down the front between the panels A and B. This is conventional and has nothing to do with the invention.

The invention will be described by reference to the articulation of one of the sleeves E. It will be understood that the other sleeve is articulated in the same manner. To the armhole margin 15 of the body is connected a ring-like insert member 35, of flexible material, for example suitable cloth, the margin of which is joined to the margin 15 right around the armhole. The member 35 extends inwards of the garment from the armhole when at rest as shown in FIGURE 6 to an outer circumferential margin.

A similar ring-like insert member 31 has an inner circumferential margin connected to the inner margin 19 of the sleeve and extends inwards in juxtaposed (when the garment is in relaxed condition) relationship to the member 35 to an outer circumferential margin. The outer circumferential margins of the members 31 and 35 are joined together by stitching as at 39. It is thus seen that the inner margin 19 of the sleeve is connected to the armhole margin 15 by the composite insert or tuck provided by the insert members 35 and 31 which form a bellows-like insert H which allows the inner margin 19 of the sleeve to be pulled away from the armhole margin 15, but causes it to be brought back again so that the two margins are close together when the insert is flattened out and the insert members 31 and 35 are drawn inside the garment by retaining means to be described.

For the purpose of causing the sleeve, when the garment is at rest, to be drawn inwards so that the sleeve margin 19 is close to the armhole margin 15, a retracting structure is provided. This includes an elastic member 51, connected as at 53 to the bottom of the insert H, the elastic member 51 extending outwardly to a point of connection 55 with the body of the garment. Between the members 53 and 55 the elastic member 51 is free to expand and retract. However, a narrow elongated pocket 59 covers the lower part of the member 51 so as to limit its movement other than along its length, that is to prevent its movement other than in a straight path.

An elastic member 61 is connected at one end as at 63 to the bellows-like insert H and at the other in similar bellows-like insert K at the other side of the garment. An intermediate guiding member or loop 69 is provided to prevent wandering of the elastic member 61. Another elastic member 70 is connected at one end as at 72 to the insert H and at the other to the neck portion of the garment as at 74.

A still further elastic member 71 is provided at the front of the garment and is connected to the insert as at 73 and to the body of the garment as at 75. This provides for the retraction of the front part of the insert.

It will be seen that the arrangement of the insert H at the right sleeve makes it possible for flexibility at the armpit and right around the arm opening.

When the wearer extends his arm, in any direction, the margin 19 of the sleeve will "part company" with the margin 15 of the body, but, immediately the arm is dropped into the normal or "at rest" position the retracting members 51, 61, 70 or 71, will pull the margin 19 of the sleeve back "into company" with the margin of the body of the garment.

For some purposes it may be desired to omit the flexible member 70 and connect the insert H directly by means of a shoulder seam extending through the body

portions of the garment and the insert H at the shoulder line. However, the preferable structure is the one in which the resilient connection is used at the shoulder as well as at the other positions about the margin of the insert H.

A garment of alternative construction according to the invention is shown in FIGURES 8 to 12. Like numbers have been given to the respective parts of the garment, where applicable, except that they have been raised by 100. The sleeves are shown as E', F' and the front panels A' and B'.

The particular form of the garment shown in these figures instead of employing the resilient connecting members 51, 61, 70 and 71, employs an actual vest R of resilient material, for example elastic cloth. The vest R has armhole margins connected about the inner margin of the bellows-like insert K' and the companion bellows-like insert H' and along the lines of stitching 105 and 107 to the front part of the garment. The vest may also be caught at the neckline by stitching 109. Otherwise, the vest R is free of attachment to the main body of the garment and thus is free for its resilience to act as a retracting means to keep the inserts H' and K', within the body of the garment and consequently the top margins of the sleeves substantially in register with the margins of the armhole openings.

The advantages of the garments of the invention will be apparent. It is particularly useful in bulky garments which are padded and insulated for use in arctic climates, for parachute jumping and other military and sporting uses.

While the specific forms of the invention described are weatherproof jackets of the slide-fastened type, it will be understood that this structure could be applied to other upper garments, e.g. coats, shirts, jackets and so on. The materials from which the garment may be made, may be for example, natural or synthetic fabrics or rubberized fabrics. Moreover, the garment may be made lined or unlined, or quilted or plain. The front of the garment may be provided with a slide fastener G or with any other suitable type of closure. It is understood that the structures illustrated are merely by way of example.

I claim:

1. An upper garment, comprising, a body having armholes and a sleeve having an inner margin at each of said armholes, a first continuous ring-like insert member having a circumferential margin connected to the inner margin of the sleeve and extending within the armhole to an outer circumferential margin and conforming to the contours of the body material adjacent thereto, a second ring-like insert member having an inner circumferential margin attached to the edge of each armhole and an outer circumferential margin attached to the outer circumferential margin of the first insert member to form a combined margin, resilient means for retaining the end

of each sleeve and its associated insert member within the armhole secured at the top, bottom, front and back parts of one of the insert members near its outer circumferential margin and to the garment at points spaced therefrom, means for restraining movement of the back, front and bottom resilient means to prevent rotational movement of the sleeves but to allow extension and retraction of said resilient means.

2. An upper garment, comprising, a body having armholes each having a margin and a sleeve having an inner margin at each of said armholes, a first continuous ring-like insert member having an inner circumferential margin connected to the inner margin of the sleeve and extending within the armhole to an outer circumferential margin and conforming to the contours of the body material adjacent thereto and terminating in an outer circumferential margin, a second ring-like insert member having an inner circumferential margin attached to the margin of each armhole and an outer circumferential margin attached to the outer circumferential margin of the first insert member to form a combined margin, resilient means for retaining the inner margin of each sleeve and its associated ring within the armhole in the form of a plurality of elastic straps secured at the top, bottom, front and back parts of the said combined margin and to the garment at points spaced therefrom, means for restraining movement of the back, front and bottom straps to prevent rotational movement of the sleeve margin but to allow extension and retraction of each strap in the form of guiding loops attached to the garment body and encircling the straps.

3. An upper garment, comprising, a body having a neck opening and armholes each having a margin and a sleeve having an inner margin at each of said armholes, a first continuous ring having an inner circumferential margin connected to the margins of the said panels at the armhole and extending within the armhole to an outer circumferential margin and conforming to the contours of the body material adjacent thereto, a second ring-like insert member having an inner circumferential margin attached to the edge of each armhole and an outer circumferential margin attached to the outer circumferential margin of the first ring to form a combined margin, resilient means for retaining the end of each sleeve and its associated ring within the armhole in the form of a vest having armhole margins connected to said combined margin and to the garment body at the neck opening and adjacent the centre of the front of the body.

References Cited in the file of this patent

UNITED STATES PATENTS

2,457,356 Enck ----- Dec. 28, 1948
2,514,276 Berman ----- July 4, 1950

FOREIGN PATENTS

5,978 Great Britain ----- Apr. 7, 1891