



US 20090090831A1

(19) **United States**

(12) **Patent Application Publication**  
**HENNING et al.**

(10) **Pub. No.: US 2009/0090831 A1**

(43) **Pub. Date: Apr. 9, 2009**

(54) **FLAT PANEL MONITOR SUPPORT ARM**

**Publication Classification**

(76) Inventors: **GERALD W. HENNING**, Spring Lake, MI (US); **Bruce R. Johnson**, Muskegon, MI (US)

(51) **Int. Cl.**  
**A47B 96/06** (2006.01)

(52) **U.S. Cl.** ..... **248/278.1; 248/276.1**

Correspondence Address:  
**VARNUM, RIDDERING, SCHMIDT & HOWLETT LLP**  
**333 BRIDGE STREET, NW, P.O. BOX 352**  
**GRAND RAPIDS, MI 49501-0352 (US)**

(57) **ABSTRACT**

A support arm for components such as flat screen monitors. In one embodiment, the support arm includes rigid arm segment and a flexible arm segment. The flexible arm segment may be mounted adjacent to the supported component. The flexible arm segment includes a plurality of flexible tubes, each having a core surrounding by a filling material and a flexible coiled tube. Preferably, at least one of the flexible tubes is fixed at both ends while at least one of the flexible tubes includes a free floating end that is permitted to move longitudinally with respect to the fixed tube as the flexible arm is moved.

(21) Appl. No.: **12/119,236**

(22) Filed: **May 12, 2008**

**Related U.S. Application Data**

(63) Continuation of application No. 10/618,270, filed on Jul. 11, 2003, now abandoned.

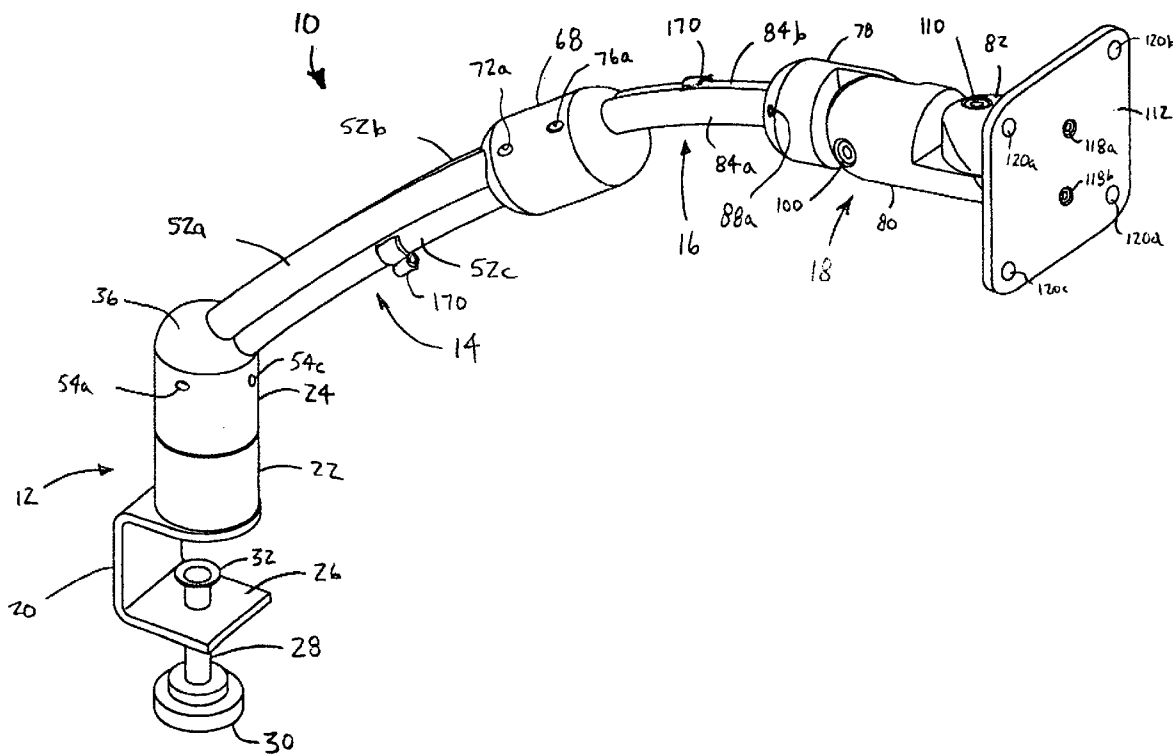



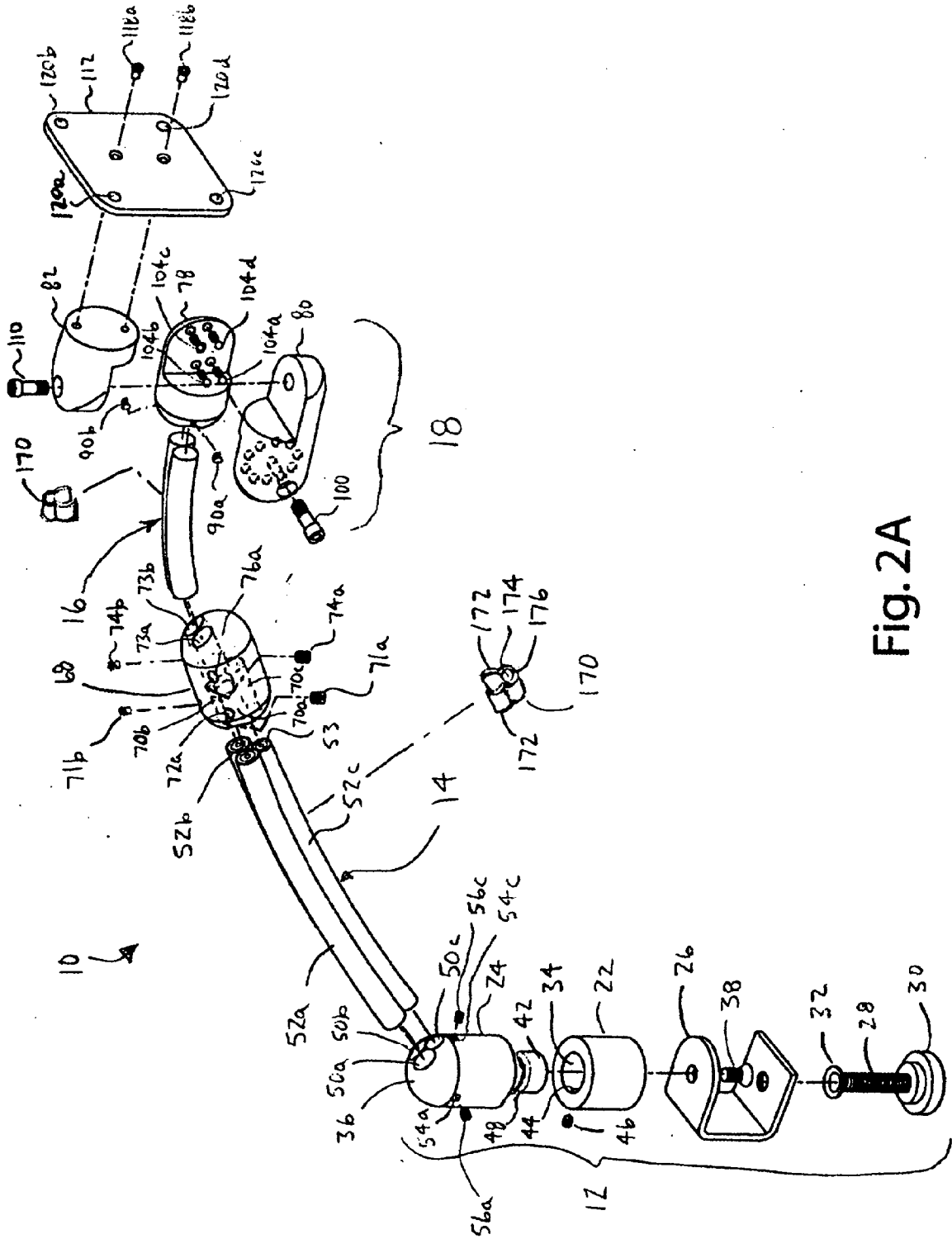

Fig. 2A

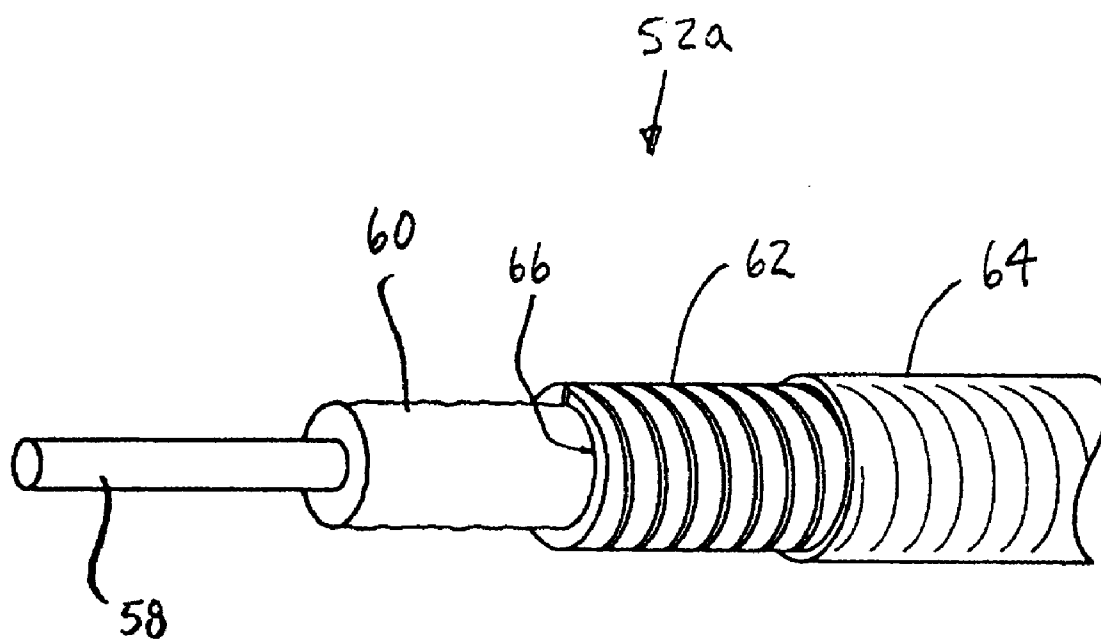

Fig. 2B

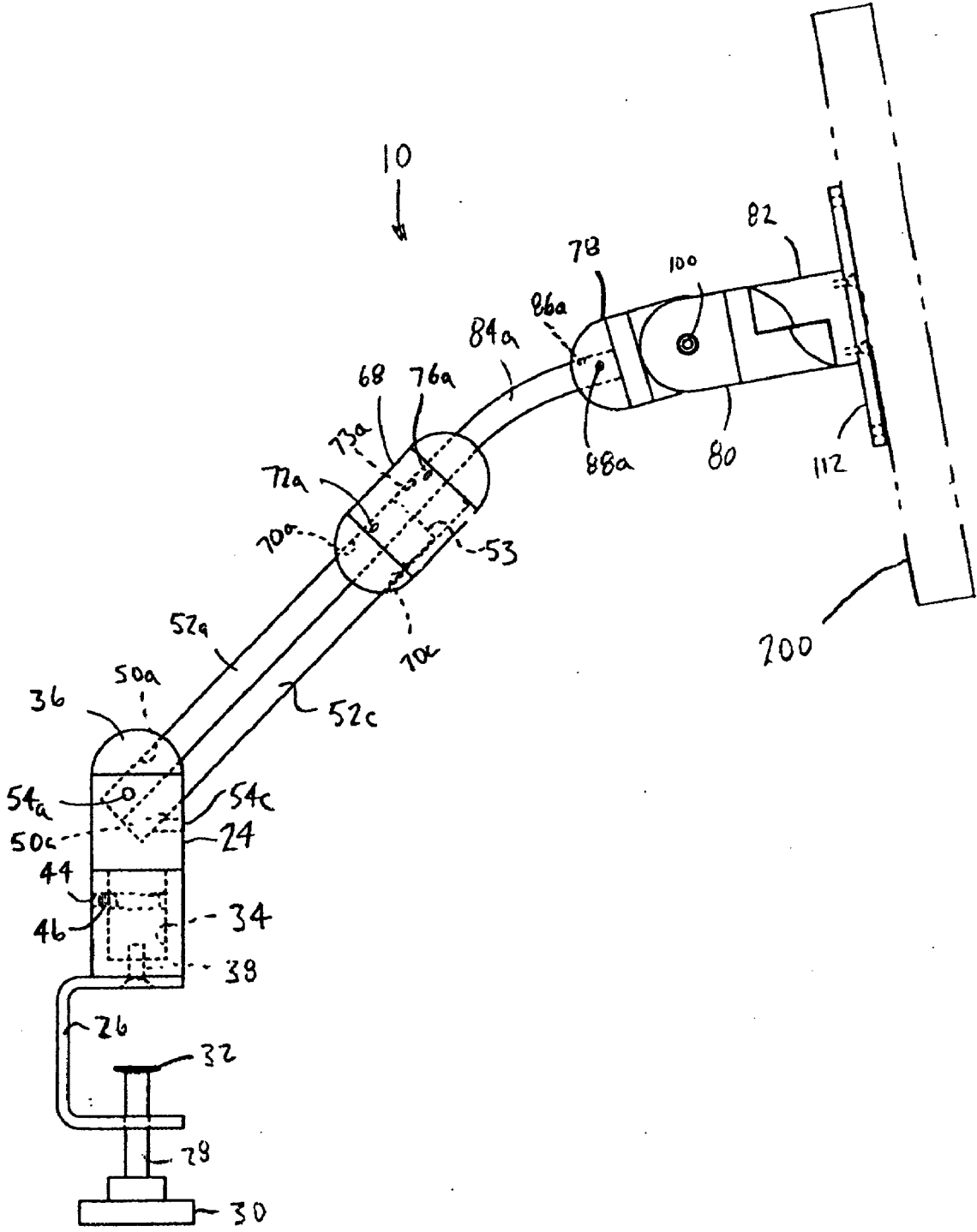

Fig. 3A

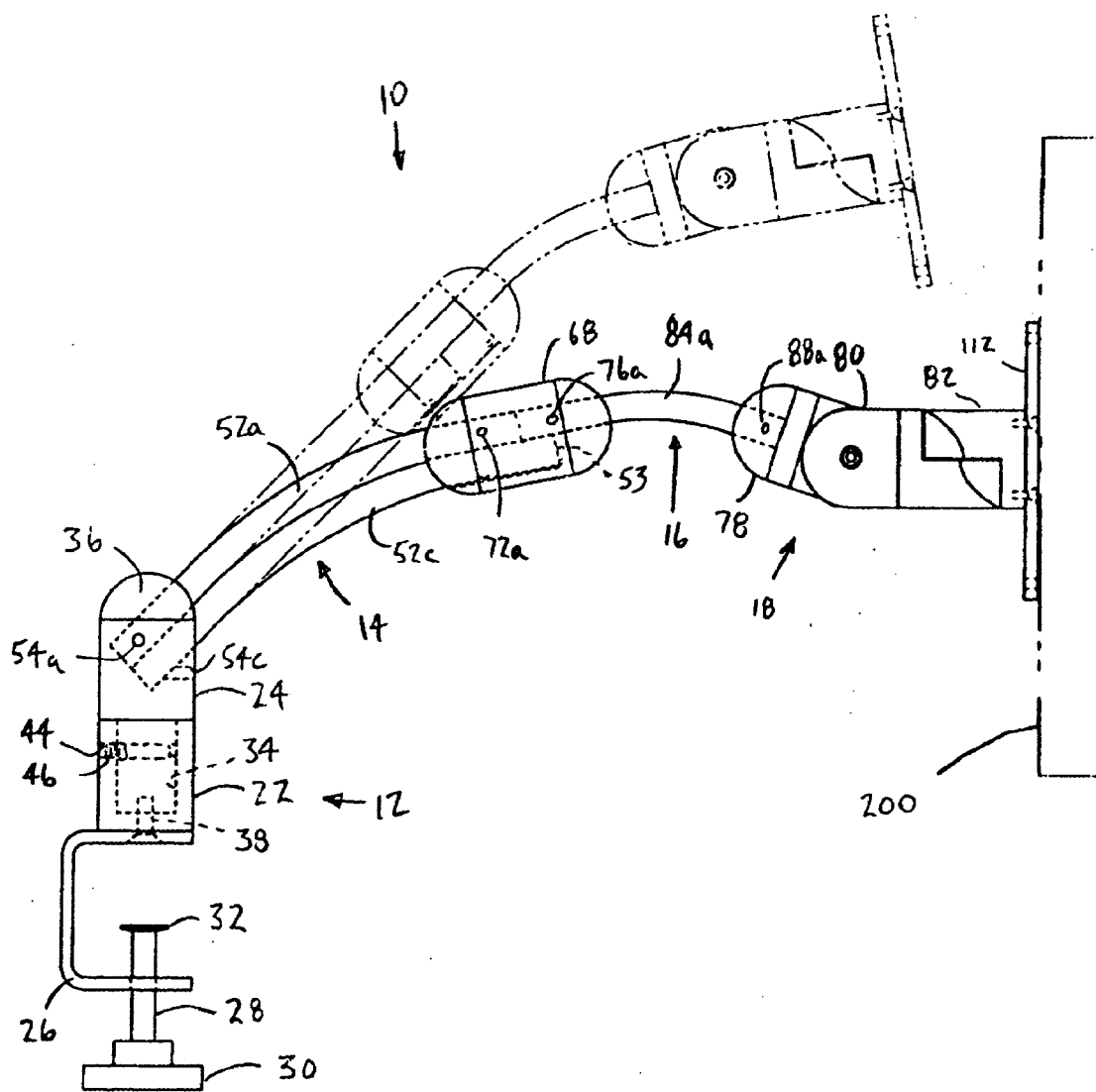

Fig. 3B

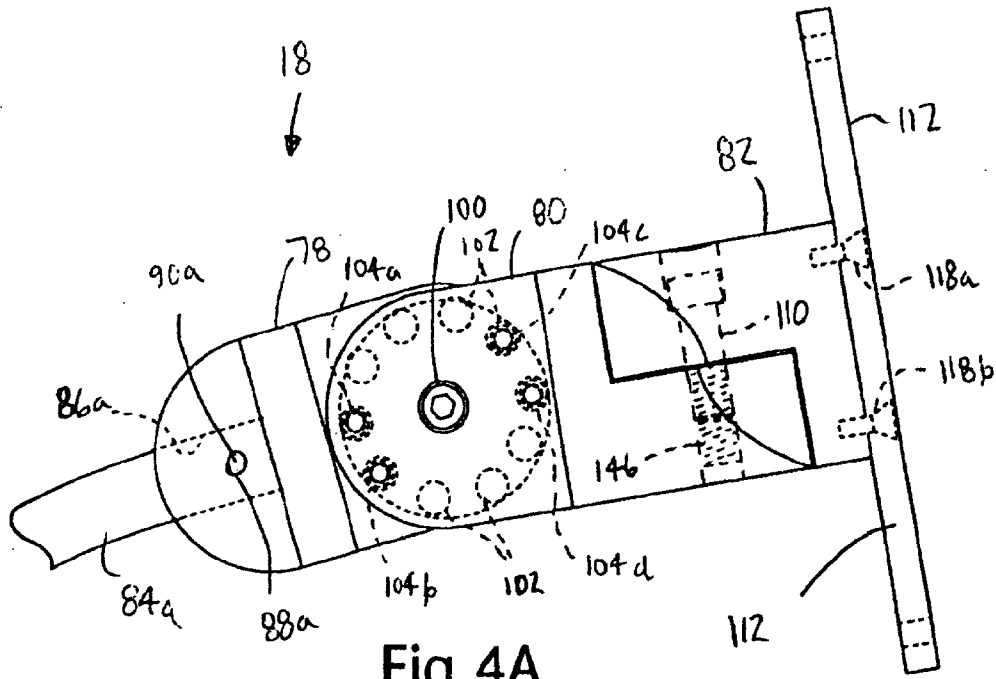

Fig. 4A

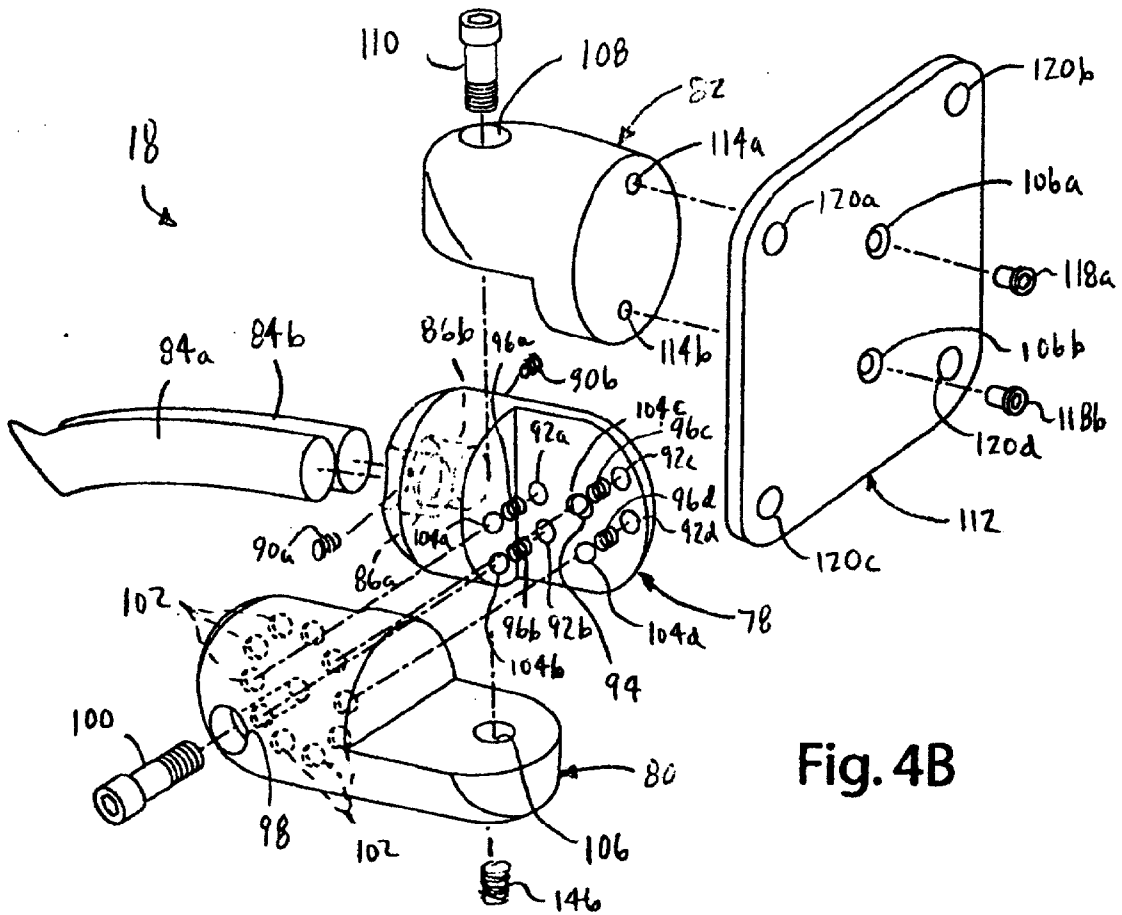

Fig. 4B

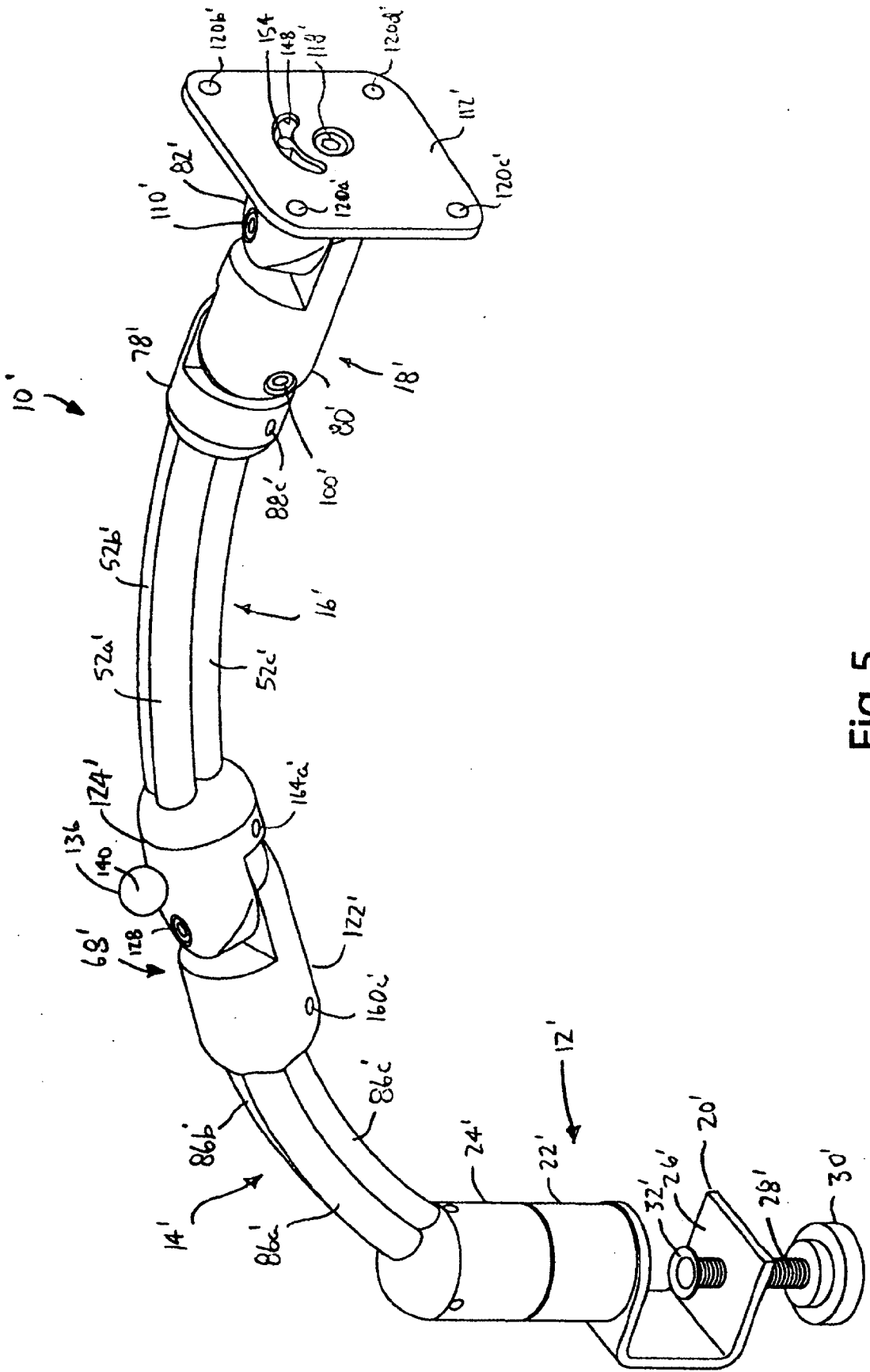

Fig. 5



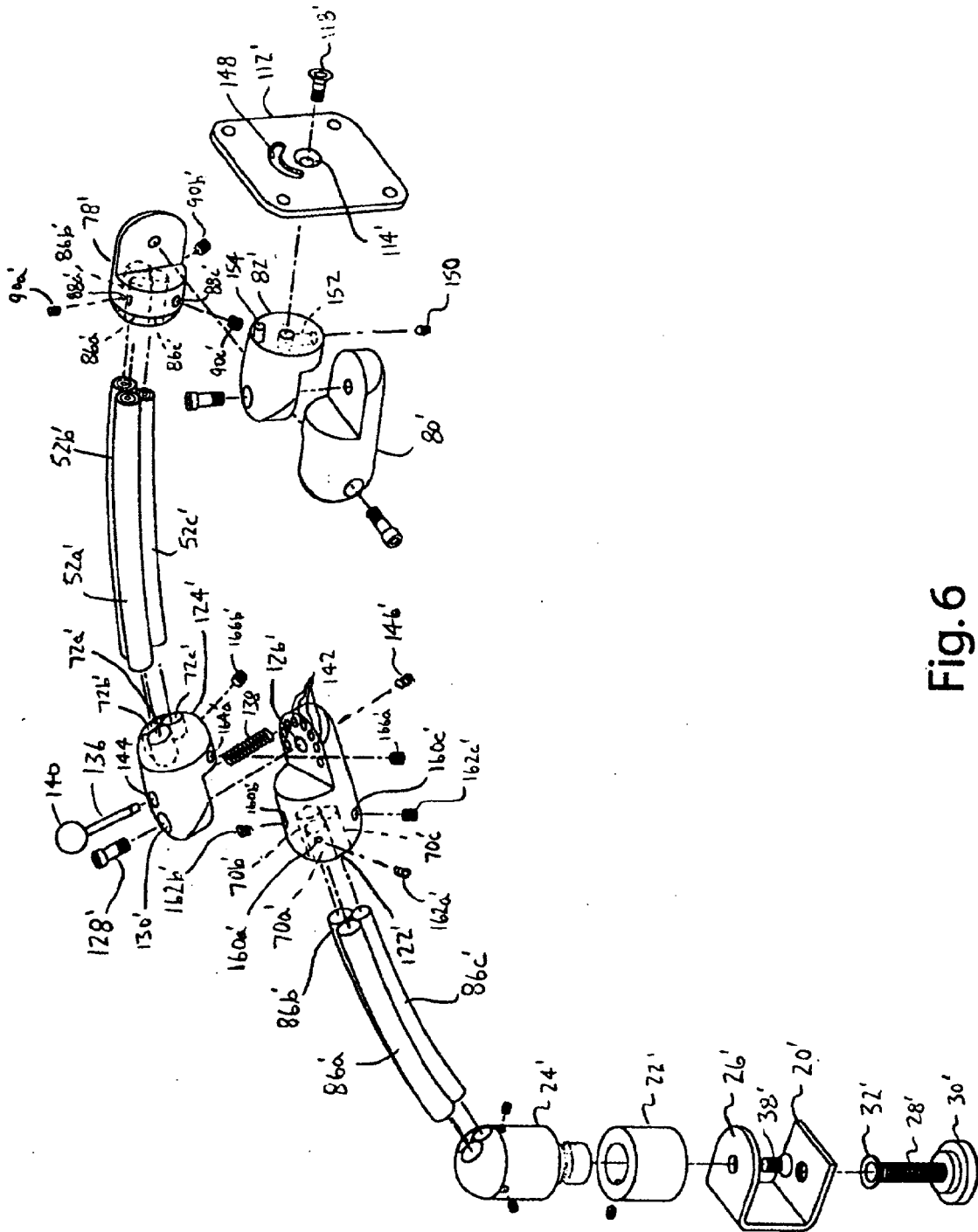

Fig. 6

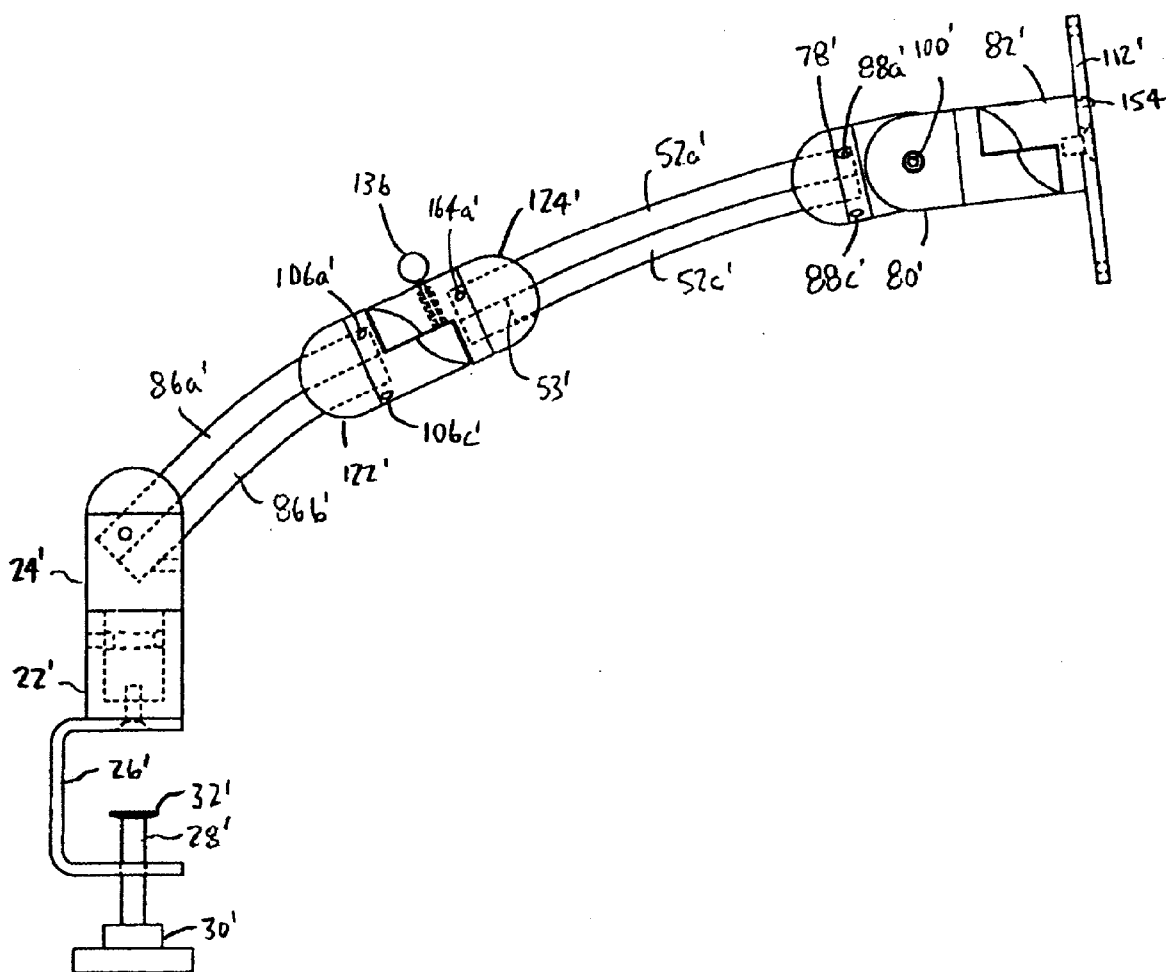

Fig. 7A

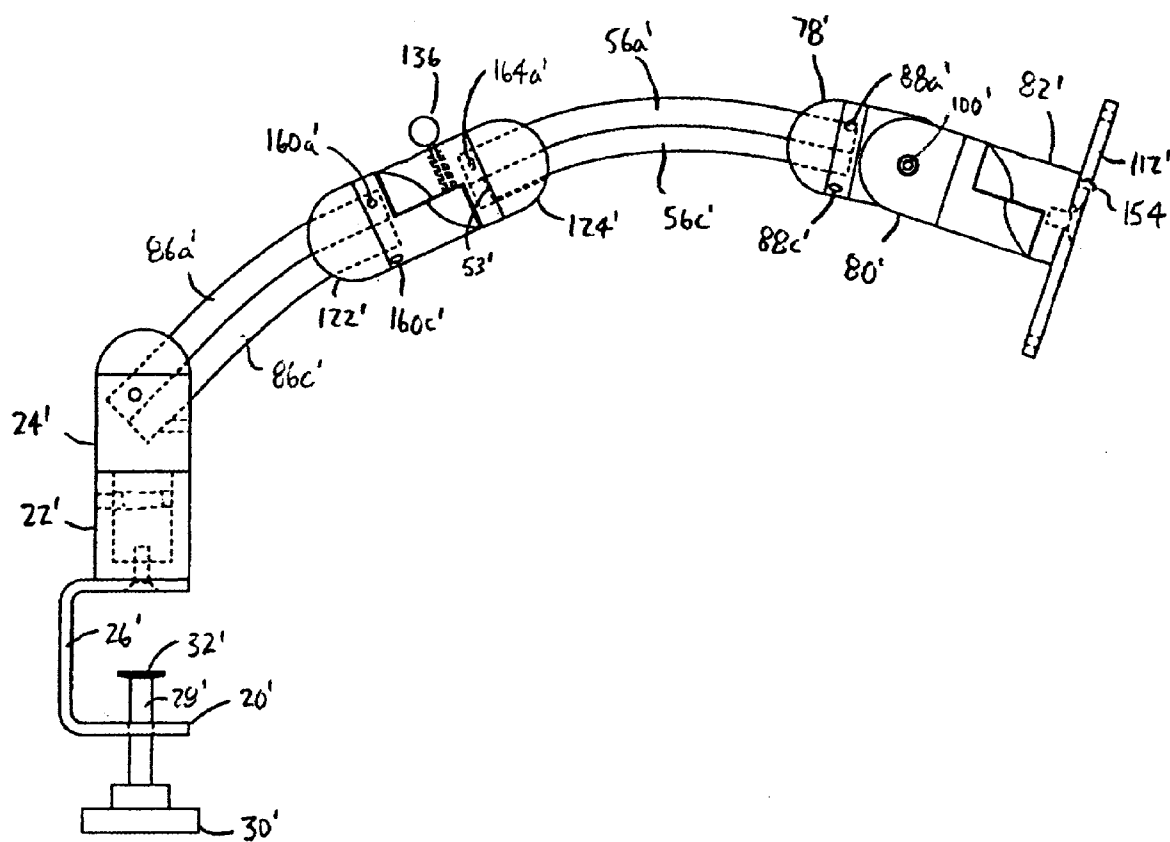

Fig. 7B

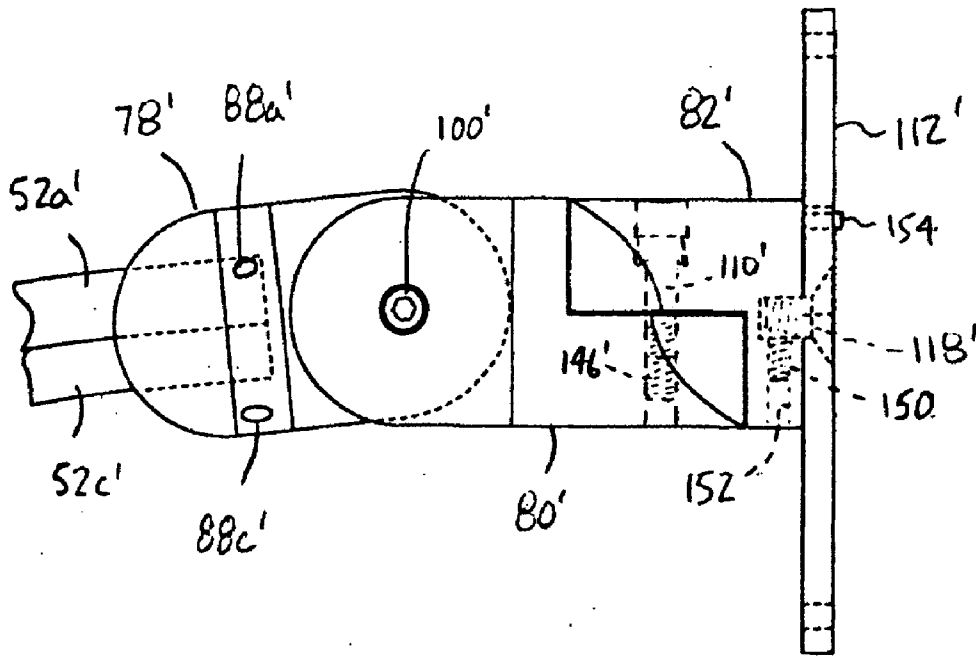

Fig. 8

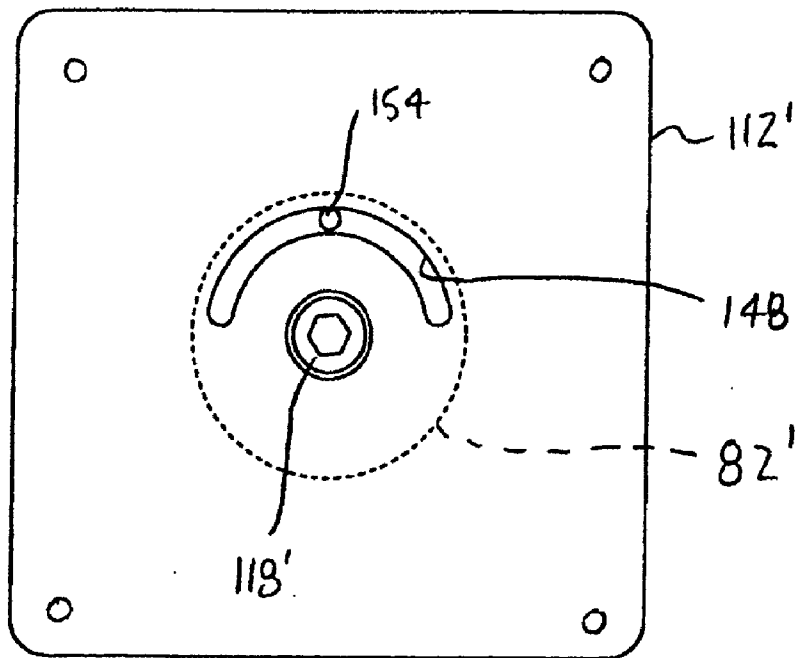

Fig. 9

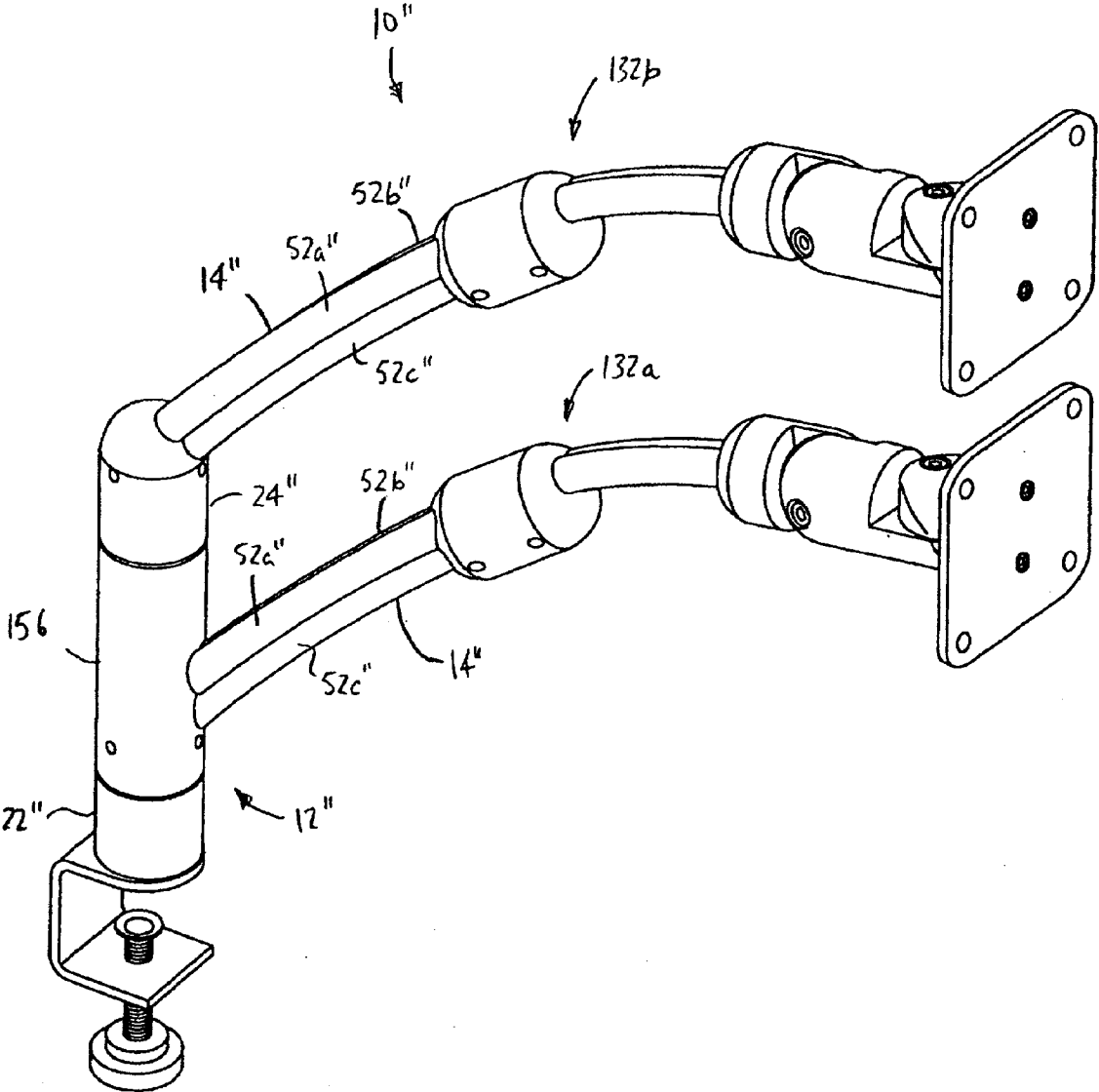
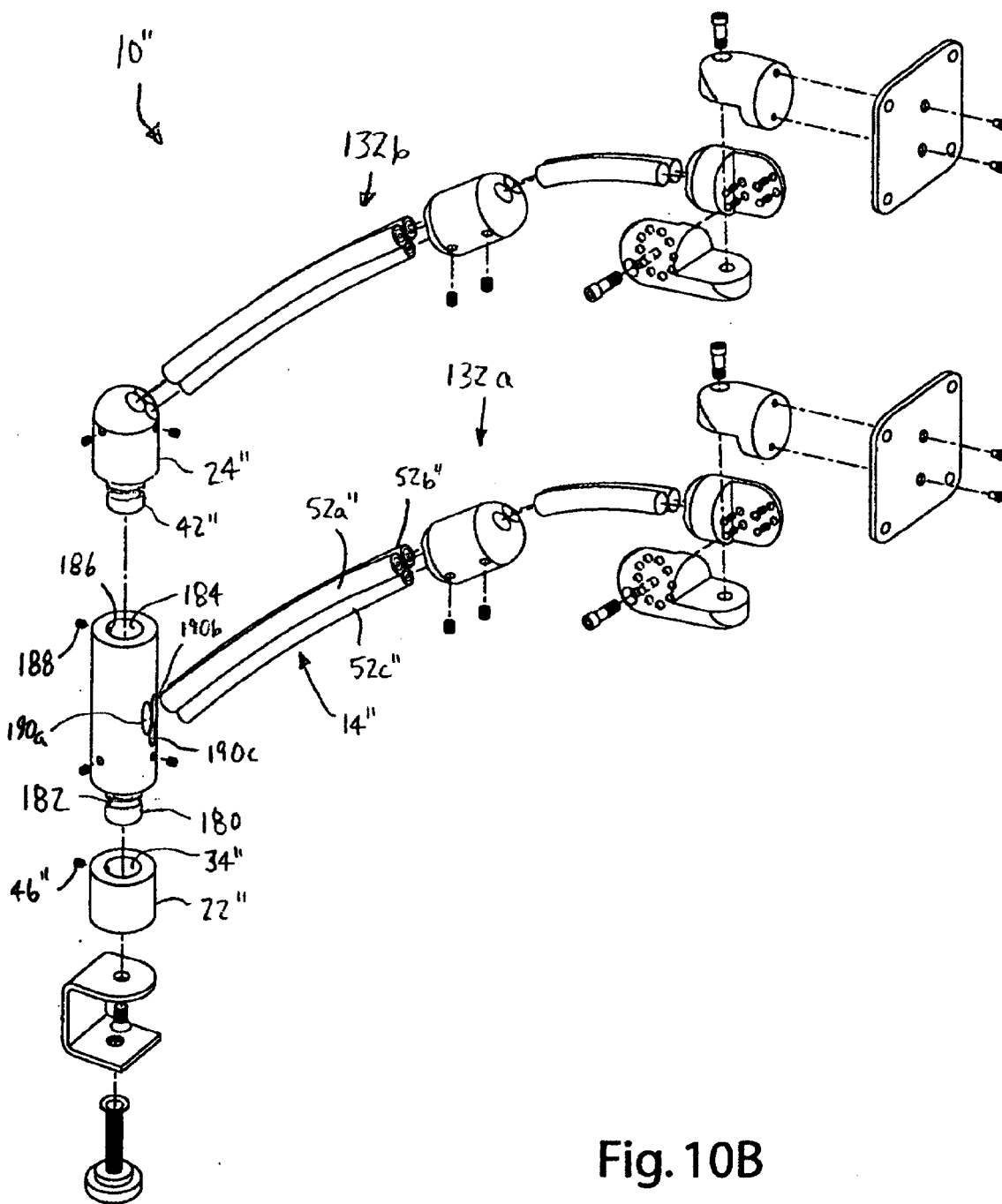

Fig. 10A



**FLAT PANEL MONITOR SUPPORT ARM**

**BACKGROUND OF THE INVENTION**

[0001] The present invention relates to support arms, and more particularly to an adjustable support arm for components such as flat panel monitors.

[0002] Conventional CRT computer monitors suffer in that they are large and relatively heavy. As a result of their weight, conventional CRT monitors are typically placed directly on a desk or other work surface. Although conventional CRT monitors are mounted on support arms in some applications, this option is not practical in many situations. Support arms for conventional CRT monitors are relatively expensive and they must be mounted to a strong and durable mounting structure. Accordingly, conventional CRT monitors often occupy valuable desk space that could be better used for other things.

[0003] As a result of these and other problems, there is a steady increase in the use of flat panel monitors as a replacement for conventional CRT computer monitors. Flat panel monitors occupy dramatically less space and are significantly lighter in weight than conventional CRT computer monitors. As a result of their reduced weight, flat panel monitors are also more easily supported above a desk or other work surface by a support arm. Although they are lighter than conventional CRT monitors, flat panel monitors are relatively heavy and still require strong and durable support arms. Conventional support arms typically include large rigid arm segments that are joined by complex durable joints. Although these conventional joints provide a level of adjustability, they are often difficult to operate and provide a limit range of adjustability. With many conventional support arms, the joints must be unlocked to make adjustments to the position of the monitor and then relocked once the monitor is in place. Accordingly, conventional support arms are typically relatively expensive, provide limited range of motion and require significant effort to adjust. As a result, there remains a continuing need for a flat panel monitor support arm that is inexpensive, easy to operate and highly adjustable.

**SUMMARY OF THE INVENTION**

[0004] The aforementioned problems are overcome by the present invention wherein a support arm for a component, such as a flat panel monitor, is provided with a plurality of flexible support members. The flexible support members are preferably mounted adjacent to one another to cooperatively provide sufficient support for the component. In one embodiment, one end of at least one of the flexible support members is free floating to permit it to move longitudinally with respect to the other flexible support members as the arm is support arm moved.

[0005] In one embodiment, the support arm includes two flexible support members, one disposed vertically above the other. The two support members each include a first end that is fixed to a common base at one end and a second end that terminates at a component mount. The component mount is adapted to receive a component, such as a flat panel monitor. The second end of one of the two support members is fixed to the component mount while the second end of the other support member is left free floating within a slide channel. This permits the support members to move longitudinally with respect to one another as the flexible support members are moved.

[0006] In one embodiment, each flexible support member includes a spiral-wrapped, flexible steel tube, a solid core disposed coaxially within the flexible tube and a filler material filling the space between the tube and the core. The filler material may be a conventional silicone caulking.

[0007] In another embodiment, the support arm includes a rigid lower arm segment and a flexible upper arm segment. By locating the flexible arm segment adjacent to the component, the moment arm applied to the flexible arm segment is reduced. In heavier applications, this can eliminate or dramatically reduce any creep that may occur in the flexible arm segment.

[0008] The present invention provides an inexpensive and highly adjustable support arm. The flexible support members provide essentially infinite adjustability without the need to operate the locking and release mechanisms incorporated into conventional rigid joints. The use of a flexible tube with one free-floating end facilitates movement of the flexible arms, maintaining support while making it easier to move the arm through a wider range of motion. The flexible arm segments are inexpensive and easily manufacture from conventional components. The combination of a solid core, coiled steel tube and silicone filling material provide the desired strength, while still permitting easy adjustment of the supported structure. The precise strength of the flexible support members can be easily controlled by varying the characteristics of the various components, for example, by varying the material or diameter of the core. Further, by providing a rigid lower arm segment and a flexible upper arm segment, the present invention is easily adapted for use in supporting heavier objects.

[0009] These and other objects, advantages, and features of the invention will be readily understood and appreciated by reference to the detailed description of the preferred embodiment and the drawings.

**BRIEF DESCRIPTION OF THE DRAWINGS**

[0010] FIG. 1 is a perspective view of a support arm in accordance with an embodiment of the present invention;

[0011] FIG. 2A is an exploded perspective view of the support arm;

[0012] FIG. 2B is a cut away view of a flexible support member;

[0013] FIG. 3A is a side elevational view of a portion of the support arm showing the base, lower arm segment and coupling in a first position;

[0014] FIG. 3B is a side elevational view of a portion of the support arm showing the base, lower arm segment and coupling in a second position;

[0015] FIG. 4A is a side elevational view of a portion of the support arm showing the upper arm segment and joint assembly;

[0016] FIG. 4B is an exploded view of a portion of the support arm showing the upper arm segment and joint assembly;

[0017] FIG. 5 is a perspective view of a first alternative embodiment of the present invention;

[0018] FIG. 6 is an exploded perspective view of the first alternative embodiment;

[0019] FIG. 7A is a side elevational view of a portion of the first alternative embodiment showing a portion of the lower arm segment, the coupling and the joint assembly in a first position;

[0020] FIG. 7B is a side elevational view of a portion of the first alternative embodiment showing a portion of the lower arm segment, the coupling and the joint assembly in a second position;

[0021] FIG. 8 is a side elevational view of the upper joint assembly of the first alternative embodiment;

[0022] FIG. 9 is a front elevational view of the upper joint assembly of the first alternative embodiment;

[0023] FIG. 10A is a perspective view of the second alternative embodiment; and

[0024] FIG. 10B is an exploded perspective view of portions of the second alternative.

#### DETAILED DESCRIPTION OF THE PREFERRED EMBODIMENT

[0025] A flat panel monitor support arm in accordance with a preferred embodiment of the present invention is shown in FIG. 1, and generally designated 10. Although the present invention is described in connection with a flat panel monitor support arm, the present invention is well suited for use with support arms for other objects, such as flat screen televisions, touch screen, etc. Referring now to FIG. 2, the support arm 10 generally includes a base assembly 12 that permits the support arm 10 to clamp to a mounting surface, such as a desk top (not shown), a flexible lower arm segment 14 that is mounted to the base assembly 12, a rigid upper arm segment 16 mounted to the lower arm segment 14 and an upper joint assembly 18 mounted to the upper arm segment 16. The lower arm segment 14 is flexible to provide easy adjust of the flat panel monitor 200. In the illustrated embodiment, the lower arm segment 14 includes three flexible tubes 52a-c that are easily bent to vary the position of the flat panel monitor 200 (See FIG. 3A). All three of the tubes 52a-c are fixed to the base assembly 12, while at least one of the tubes 52a-c is free floating at its opposite end to flexing movement of the lower arm segment 14.

[0026] In the illustrated embodiment, the base assembly 12 generally includes a clamp 20, a lower swivel mount 22 and an upper swivel mount 24 (See FIG. 2A). The clamp 20 includes a generally C-shaped bracket 26 and a threaded clamp post 28 that is threadedly engaged with the bracket 26. A conventional hand knob 30 and a clamp foot 32 are affixed to opposite ends of the clamp post 28. Manual rotation of the hand knob 30 permits the support arm 10 to be easily mounted to a support structure, such as a desk top (not shown). Although the present invention is described in connection with a generally conventional screw-actuated clamp assembly, the present invention may include alternative mounting mechanisms. For example, the screw-actuated clamp assembly may be replaced by conventional cam-actuated or spring-actuated clamp assemblies. In other alternatives, the clamp 20 may be eliminated and the support arm 10 may be attached to the support structure by adhesive, screws, bolts or other fasteners. In this embodiment, the lower swivel mount 22 is fixedly secured to the bracket 26, for example, by a screw 38 and lock-nut 40. Alternatively, the lower swivel mount 22 and bracket 26 can be integrally formed or secured by welding, adhesives or other conventional methods. As perhaps best shown in FIGS. 2A, 3A and 3B, the lower swivel mount 22 is generally cylindrical and defines an internal bore 34. The internal bore 34 is adapted to receive the pivot post 42 of the upper swivel mount 24. The lower swivel mount 22 also defines a threaded hole 44 to receive a set screw 46 for pivotally securing the pivot post 42 in the internal bore 34.

[0027] The upper swivel mount 24 is rotatably mounted to the lower swivel mount 22 to permit the support arm 10 to rotate in through a generally horizontal plane. Referring again to FIG. 2A, the upper swivel mount 24 is generally cylindrical with a rounded head 36. A pivot post 42 protrudes from the undersurface of the lower swivel mount 22. As noted above, the pivot post 42 is fitted within the internal bore 34 of the lower swivel mount 22. The pivot post 42 has an outer diameter that is only slightly smaller than the internal diameter of the internal bore 34 of the lower swivel mount 22. The pivot post 42 defines an annular recess 48 that loosely receives set screw 46 to interconnect the lower swivel mount 22 and the upper swivel mount 24. The upper swivel mount 24 also defines a plurality of arm mounting bores 50a-c, one to receive each of the flexible tubes 52a-c. The upper swivel mount 24 further includes a plurality of set screw holes 54a-c, each to receive a set screw 56a-c for securing each of the flexible tubes 52a-c in the corresponding arm mounting bore 50a-c.

[0028] As noted above, the lower arm segment 14 includes a plurality of flexible tubes 52a-c (See FIGS. 2B-3B). In the illustrated embodiment, the lower arm segment 14 includes three flexible tubes 52a-c, but the number of flexible tubes can vary from application to application. Referring now to FIG. 2B, each flexible tube 52a-c generally includes a core 58, a filler 60 surrounding the core 58, a casing 62 surrounding the core 58 and filler 60 and a flexible sleeve 64 surrounding the casing 62. The core 58 is preferably manufactured from solid metal, for example, one-quarter inch copper round stock or 0.156 inch annealed steel or annealed aluminum round stock. The size, shape and configuration of the core 58 may vary from application to application. For example, the core 58 may be manufactured from a hollow core material or from other flexible materials. In this embodiment, the casing 62 is a generally conventional flexible steel tube formed from helically wound spring steel. The flexible steel tube can be replaced by other flexible casing materials depending primarily on the desired strength of the flexible tubes 52a-c. For example, in some applications it may be desirable to replace the flexible steel tube with a flexible plastic tube, such as a conventional "accordion-style" plastic tube. The inner diameter of the casing 62 is preferably substantially greater than the outer diameter of the core 58 so that an internal void 66 is disposed between the core 58 and the casing 62. The void 66 is preferably filled with a filler 60, such as generally conventional silicone caulking. Other filler materials may be used in place of the silicone caulking. The filler 60 may be selected to increase or decrease the strength (e.g. flexibility or resistance to bending) of the flexible tubes 52a-c.

[0029] It is desirable to match the strength (e.g. flexibility or resistance to bending) of the lower arm segment 14 to the weight of the component to be support, such as a flat panel monitor 200. As the force required to bend the lower arm segment 14 increases, so does the effort required to adjust the position of the monitor 200. On the other hand, if the force required to bend the lower arm segment 14 is too low, the support arm 10 may creep or fall under the weight of the monitor 200. With a conventional 15" flat panel monitor weighing approximately 7 to 9 pounds, the desired balance can be achieved by providing a core 58 of conventional annealed steel or annealed aluminum round stock with a diameter of 0.156 inches, a filler 60 of 100 percent silicone



caulking, a casing 62 of conventional five eighth inch outer diameter flexible steel tube and a sleeve 64 of heat-shrink plastic.

[0030] Referring again to FIGS. 2A and 3A-B, the support arm 10 includes a coupling 68 that mounts to the free end of the lower arm segment 14. In this embodiment, two of the flexible tubes 52a-b are fixedly secured to the coupling 68, while the third flexible tube 52c is free floating with respect to the coupling 68. More specifically, the coupling 68 defines three lower arm mounting bores 70a-c, which preferably extend parallel to one another and to the central axis of the coupling 68 (See FIG. 2A). Set screw holes 72a-b are defined in communication with lower arm mounting bores 70a-b for securing the corresponding flexible tubes 52a-b within the bores 70a-b by set screws 71a-b. The third lower arm mounting bore 70c receives the free end 53 of the third flexible tube 52c. As perhaps best shown in FIGS. 3a and 3b, the free end of the third flexible tube 52c terminates within the third lower arm mounting bore 70c. The flexible tube 52c is not, however, fixed within the third bore 70c. Instead, the third flexible tube 52c is permitted to move freely within the third lower arm mounting bore 70c as the lower arm segment 14 is bent in one direction or another. The free floating nature is perhaps best understood by comparison of the position of the free end 53 of flexible tube 52c within the third bore 70c in FIGS. 3A and 3B. This improves the flexibility and increases the available range of motion of the lower arm segment 14. Alternatively, the flexible tube 52c can be fixed to the coupling 68 and free floating with respect to the base 12 to provide similar functional benefits. The coupling 68 also defines a pair of upper arm bores 73a-b for receiving the upper arm segment 16. The upper arm bores 73a-b closely receive the two tube segments 84a-b (described below) of the upper arm segment 16. The coupling 68 may also define set screw holes 76a-b for securing the two tube segments 84a-b to the coupling 68 by set screws 74a-b. The upper arm bores 73a-b and lower arm bores 70a-b may be continuous with one another if desired. More specifically, upper arm bore 73a and lower arm bore 70a may be opposite ends of a single bore extending entirely through the coupling 68 and, likewise, upper arm bore 73b and lower arm bore 70b may be opposite ends of a single bore extending entirely through the coupling 68.

[0031] The upper arm segment 16 of the described embodiment extends from the coupling 68 to support the upper joint assembly 18. In this embodiment, the upper arm segment 16 includes two adjacent segments of rigid tube 84a-b, for example, 0.720 inch diameter steel tube (See FIGS. 2A and 3A-B). The size, shape and configuration of the upper arm segment 16 may vary from application to application depending primarily on the desired strength and aesthetic characteristics. For example, the rigid tube segments 84a-b may be replaced by other rigid materials or by a flexible upper arm segment 16, such as the three flexible tubes 52a-c of the lower arm segment 14.

[0032] An upper joint assembly 18 is mounted to the free end of the upper arm segment 16. The upper joint assembly 18 mounts to the flat panel monitor 200 and is adjustable in various directions to control the position of the flat panel monitor 200. As perhaps best shown in FIGS. 4A and 4B, the upper joint assembly 18 generally includes a head 78, a first joint member 80 pivotally mounted to the head 78, a second joint member 82 pivotally mounted to the first joint member 80 and a panel mounting bracket 112 secured to the second joint member 82. The head 78 mounts to the upper arm

segment 14. In the described embodiment, the head 78 defines two arm mounting bores 86a-b that receive the ends of the two tube segments 84a-b. The head 78 defines two set screw holes 88a-b for securing the tube segments 84a-b to the head 78 by set screws 90a-b. The head 78 may also define a threaded through bore 94 for securing the head 78 to the first joint member 80 and a plurality of spring seats 92a-d for seating bearing plunger springs 96a-d and plunger balls 104a-d as described in more detail below. The first joint member 80 is pivotally mounted to the head 78 to permit adjustment of the joint assembly 18 along a single plane, for example, a vertical plane in the illustrated embodiment. The first joint member 80 defines a through bore 98 for attaching the first joint member 80 to the head 78 by a conventional fastener 100. The through bore 98 may be counter-bore to provide a recess for the head of the fastener 100. To permit pivotal movement between the head 78 and the first joint member 80, the mounting fastener 100 is tightened only to the point where the desired resistance to pivotal movement is achieved. A jam screw (not shown) is threadedly inserted into threaded through bore 94 to abut and jam-lock the fastener 100 in place. The first joint member 80 also defines a plurality of plunger ball detents 102 adapted to receive plunger balls 104a-d. The plunger balls 104a-d are spring biased by springs 96a-d to bias the first joint member 80 in the positions dictated by the pattern of the detents 102. The strength of the springs 96a-d or the number of spring/ball assemblies can be selected to provide the desired biasing force. In some applications, it may be desirable to eliminate the spring/ball assemblies or replace them with conventional alternative biasing mechanisms. The first joint member 80 also defines a threaded through bore 106. The second joint member 82 defines a corresponding through bore 108 for pivotally interconnecting the first and second joint members 80 and 82 by a conventional fastener 110. The through bore 108 may be counter-bore to provide a recess for the head of the fastener 110. To permit pivotal movement between the first joint member 80 and the second joint member 82, the mounting fastener 110 is tightened only to the point where the desired resistance to pivotal movement is achieved. A jam screw 146 is threadedly inserted into through bore 106 to abut and jam-lock the fastener 110 in place (See FIG. 4A). The second joint member 82 also defines a pair of bracket mounting holes 114a-b for mounting the bracket 112 to the second joint member 82. The bracket 112 is a generally planar steel plate that defines a pair of mounting holes 116a-b for mounting the bracket 112 to the second joint member 82 by fasteners 118a-b. The bracket 112 can be mounted to the second joint member 82 by other conventional mechanisms, such as welding, adhesives or other fasteners. Alternatively, the bracket 112 and second joint member 82 can be integrally formed as a single unit. The bracket 112 also defines a plurality of mounting holes 120a-d arranged in a pattern that matches the mounting pattern of the product to be supported, such as flat panel monitor 200. As a result, the flat panel monitor 200 can be mounted to the bracket 112 by conventional fasteners (not shown). The support arm 10 can be configured to support various products by varying the mounting hole pattern or by replacing the mounting hole pattern with other conventional mounting mechanisms.

[0033] The various components of the support arm 10 are manufactured using conventional techniques and apparatus. In one embodiment, the lower swivel mount 22, upper swivel mount 24, coupling 68, head 78, first joint member 80 and second joint member 82 are machined from nylon (e.g. nylon

616) round stock having a diameter of approximately 2 inches. The nylon may be reinforced, for example, with glass fibers if desired. These components may, however, be manufactured using other conventional techniques and apparatus, such as injection molding or die casting, and using other conventional materials, such as metal, thermoplastic.

[0034] To provide a mechanism for routing power cords and other wires, the support arm 10 may include a plurality of cord clips 170 (See FIGS. 1 and 2A). The cord clips 170 are intended to snap-fit over the flexible tubes 52a-c of the lower arm segment 14 and the rigid tubes 84a-b of the upper arm segment 16. This allows the user to place the cord clips 170 as desired. Each cord clip 170 includes a pair of flexible, resilient legs 172 that are curved along a diameter that is slightly smaller than the outer diameter of the flexible tubes 52a-c and the rigid tubes 84a-b. The cord clip 170 includes a curved body 176 that defines a cord space 174 for receiving the desired power cord and other wires. The size and shape of the cord space 174 can be easily adjusted as desired by varying the size and shape of the body 176. Although two cord clips 170 are shown, the number of cord clips can vary as desired.

#### ALTERNATIVE EMBODIMENTS

[0035] The present invention is described above in connection with a support arm 10 intended to support a conventional 13-15 inch flat panel monitor. The design and configuration of the support arm can be varied to adapt the support arm to other uses. For example, the strength of the flexible lower arm segment 14 can be increased to support heavier objects or reduced to support lighter objects. Further, the size or material types of the various support arm components can be changed to provide increased or decreased strength as desired. The configuration of the support arm may also be varied, for example, by reversing the position of the lower arm segment and upper arm segment so the flexible arm segment is located adjacent to the joint assembly. In some applications, the rigid arm segment may be eliminated all together to provide an arm that is flexible along its entire length. Further, in some applications it may be desirable to vary the number of flexible tubes that are free floating at one end.

[0036] To illustrate the adaptability of the present invention, a first alternative embodiment is described in connection with FIGS. 5-9. This alternative embodiment is intended for use with larger flat panel monitors, such as 17-19 inch monitors. In this embodiment, the base assembly 12' is generally identical to the base assembly 12 described above including a clamp 20', lower swivel mount 22', upper swivel mount 24', C-shaped bracket 26' and a clamp post 28' with a knob 30' and foot 32' on opposite ends (See FIGS. 5 and 6). The various elements of the base 12' may be increased in size or manufactured from stronger materials to provide increased strength.

[0037] In this embodiment, the lower arm segment 14' is rigid and the upper arm segment 16' is flexible. As perhaps best shown in FIG. 6, the lower arm segment 14' generally includes three rigid tubes 86a-c' similar to the rigid tubes 86a-b. The rigid tubes 86a-c' preferably extend parallel to one another through a gentle arc. The rigid tubes 86a-c' are preferably manufactured from one half inch steel conduit.

[0038] The support arm 10' includes a coupling 68' interconnecting the lower arm segment 14' and the upper arm segment 16'. In this embodiment, the coupling 68' provides a joint that permits pivot movement of the upper arm segment 16'. The coupling 68' generally includes a lower half 122' and

an upper half 124'. The lower half 122' defines three lower arm mounting bores 70a-c' that are fitted over the upper ends of the rigid tubes 86a-c'. The lower half 122' preferably defines three set screw holes 160a-c' for securing the coupling to the lower arm segment 14' by set screws 162a-c'. The lower half 122' also defines a through bore 126' for pivotally mounting the lower half 122' to the upper half 124'. The through bore 126' is preferably threaded to receive a mounting fastener 128'. To permit pivotal movement in the coupling 68' the mounting fastener 128' is tightened only to the point where the desired resistance to pivotal movement is achieved. A jam screw 146' is threadedly inserted into through bore 126' to jam-lock the fastener 128' in place. The upper half 124' is similar to the lower half 122', being configured to mount to upper arm segment 16'. The upper half 124' defines three upper arm mounting bores 72a-c'. The upper half 124' preferably defines two set screw holes 164a-b' for securing the coupling to the upper arm segment 16' by set screws 166a-b'. The upper half 124' also defines a through bore 130' for pivotally mounting the lower half 122' to the upper half 124'. The through bore 130' is counter-bored to seat the head of fastener 128'. In the illustrated embodiment, the coupling 68' also includes a plunger assembly for locking the coupling 68' in one of a variety of positions. The plunger assembly generally includes a plunger pin 136 mounted in the upper half 124' that interacts with a plurality of spaced locking holes 142 defined in the lower half 122'. The plunger pin 136 is mounted in a through bore 144 defined in the upper half 124'. The plunger pin bore 144 is counter-bored to seat a plunger spring 138 around the plunger pin 136 for biasing the plunger pin 136 into engagement with the locking holes 142. The plunger pin 136 protrudes from the upper half 124' and includes a knob 140 to facilitate its actuation. In operation, the user simply disengages the plunger pin 136 by pulling on the knob 140 and then pivots the coupling 68' to the desired position. When the plunger pin 136 is released, the spring 138 will push the plunger pin 136 into engagement with any aligned locking hole 142. The plunger assembly 134 can be incorporated into one or more of the other pivot locations on the support arm 10' as desired.

[0039] The upper arm segment 16' includes three flexible tubes 52a-c'. The flexible tubes 52a-c' are generally identical to flexible tubes 52a-c', each including a core (not shown) of conventional 0.156 inch annealed steel or annealed aluminum round stock, a filler (not shown) of conventional 100 percent silicone caulking, a casing (not shown) of conventional five eighth inch outer diameter flexible steel tube and a sleeve (not numbered) of heat shrink plastic. As in support arm 10, flexible tubes 52a-b' are fixed at both ends, while flexible tube 52c' has at least one free end. In the illustrated alternative embodiment, flexible tube 52c' is fixed at one end to the upper swivel mount 24' and its other end is free floating with respect to the coupling 68'. Movement of flexible tube 52c' is perhaps best seen by comparing the position of the free end 53' of tube 52c' in FIGS. 7A and 7B. Alternatively, the third flexible tube 52c' can be fixed to the coupling 68' and free floating with respect to the upper swivel mount 24'.

[0040] The upper joint assembly 18' is largely identical to upper joint assembly 18 except as described below. As perhaps best shown in FIG. 8, the upper joint assembly 18' generally includes a head 78', a first joint member 80', a second joint member 82' and a bracket 112'. The head 78', first joint member 80' and second joint member 82' are pivotally interconnected to provide two axes of pivotal motion. Unlike

the head 78 described above, the head 78' defines three arm mounting bores 86a-c' to mount the three flexible tubes 52a-c' of the upper arm segment 16'. The head 78' includes three set screw holes 88a-c' for locking flexible tubes 52a-c' in place within the corresponding mounting bores 86a-c' by set screw 90a-c'.

[0041] In this alternative embodiment, the bracket 112' is pivotally mounted to the upper joint assembly 18' to permit rotational movement of the flat panel monitor 200. As shown in FIGS. 6 and 9, the bracket 112' includes a central bracket mounting hole 114' for securing the bracket 112' to the second joint member 82' by a threaded fastener 118'. To permit rotational movement of the bracket 112' the fastener 118' is tightened only to the point where the desired resistance to movement is achieved. A set screw 150 is threadedly inserted into set screw hole 152 defined in the second joint member 82' to lock the fastener 118' in place. To limit rotational movement of the bracket 112', the second joint member 82' includes a limit pin 154 that interacts with an arcuate slot 148 defined in the bracket 112' (See FIGS. 6 and 9). More specifically, a limit pin 154 protrudes from the second joint member 82' into the arcuate slot 148 in the bracket 112'. The limit pin 154 may be threaded or frictionally fitted into a bore (not shown) in the second joint member 82'. Alternatively, the limit pin 154 may be integrally formed with second joint member 82'. As the bracket 112' is rotated, the limit pin 154 moves along the arcuate slot 148. Movement of the bracket 112' is permitted until the limit pin 154 reaches either end of the slot 148. In this way, the arcuate slot 148 defines the range of motion of the bracket 112'.

[0042] A second alternative embodiment is shown in FIGS. 10A and 10B. In this embodiment, the support arm 10" is configured to mount two separate objects, such as two flat panel monitors. As shown, the support arm 10" includes two arms 132a and 132b mounted to a common base assembly 12". The arms 132a and 132b may be of any construction disclosed herein, however, in the illustrated embodiment, each arm 132a and 132b has essentially the same construction as support arm 10. Referring now to FIG. 10, the base 12" includes a lower swivel mount 22" and an upper swivel mount 24" that are generally identical to the lower swivel mount 22 and upper swivel mount 24 described above. In addition, the base 12" includes a central swivel mount 156 that is interposed between the lower swivel mount 22" and the upper swivel mount 24". The central swivel mount 156 includes a pivot post 180 that is pivotally fitted into the bore 34" of the lower swivel 22". The pivot post 180 is generally identical to pivot post 42 and it includes an annular recess 182 for securing the central swivel mount 156 by set screw 46". The central swivel mount 156 defines an internal bore 184 adapted to receive the pivot post 42" of the upper swivel mount 24". The central swivel mount 156 also defines a threaded set screw hole 186 to receive a set screw 188 for pivotally securing the pivot post 42" of the upper swivel mount 24" in the internal bore 184. The arm 132a is mounted to the central swivel mount 156. In this embodiment, the central swivel mount 156 defines a plurality of bores 190a-c for mounting the flexible tubes 52a-c" of the lower arm segment 14" of arm 132a. More specifically, the central swivel mount 156 defines three bores 190a-c, each adapted to receive the ends of the flexible tubes 52a-c". The central swivel mount 156 preferably includes set screws for securing the flexible tubes 52a-c to the base 12". The second arm 132b is mounted to the upper swivel mount 24" in the same manner described above in connection with support arm 10. Accordingly, that structure will not be again described here. As can be seen, the central swivel mount 156

provides a simple structure for permitting multiple components to be supported by the same base.

[0043] The above description is that of various preferred embodiments of the invention. Various alterations and changes can be made without departing from the spirit and broader aspects of the invention as defined in the appended claims, which are to be interpreted in accordance with the principles of patent law including the doctrine of equivalents. Any reference to claim elements in the singular, for example, using the articles "a," "an," "the" or "said," is not to be construed as limiting the element to the singular.

1. A support arm comprising:

a base having a mounting means for mounting said base to a mounting structure;

a rigid arm segment;

a flexible arm segment, said rigid arm segment and said flexible arm segment being connected to one another, said interconnected segments having a first end and a second end, said first end being connected to said base; and

a component mount connected to said second end of said interconnected segments.

2. The support arm of claim 1 wherein said flexible arm segment includes a plurality of discrete flexible tubes extending substantially parallel to one another.

3. The support arm of claim 2 wherein each of said plurality of flexible tubes includes a first end and a second end, at least one of said flexible tubes including a fixed first end and a fixed second end, at least one of said flexible tubes including a free floating first end.

4. The support arm of claim 3 further comprising a joint interconnecting said rigid arm segment and said flexible arm segment.

5. The support arm of claim 4 wherein said joint includes a locking mechanism for selectively locking said joint in a desired position.

6. The support arm of claim 3 further comprising a joint disposed between said interconnected segments and said component mount.

7. The support arm of claim 1 wherein said flexible arm segment includes at least one flexible tube, said flexible tube including a core, a flexible casing surrounding said core in a spaced apart relationship to define a void, and a filler material substantially filling said void.

8. The support arm of claim 7 wherein said core is a solid metal round stock.

9. The support arm of claim 8 wherein said filling material is a silicone caulk.

10. The support arm of claim 9 wherein said casing is a flexible coiled steel tube.

11. The support arm of claim 5 wherein said rigid arm segment is secured to said base and said flexible arm segment is secured to said component mount.

12. The support arm of claim 1 further comprising a second rigid arm segment, a second flexible arm segment and a second component mount; and

wherein said second rigid arm segment, said second flexible arm segment and said second component mount are connected to said base.

13. A support arm comprising:

a mounting base;

a first arm segment mounted to said base;

a second arm segment mounted to said first arm segment opposite said base; and

a component mount connected to said second arm segment, wherein at least one of said first arm segment and said second arm second is a flexible arm segment.

14. The support arm of claim 13 wherein said flexible arm segment includes a plurality of discrete flexible tubes extending substantially parallel to one another.

15. The support arm of claim 13 wherein each of said plurality of flexible tubes includes a first end and a second end, at least one of said flexible tubes is a fixed tube including a fixed first end and a fixed second end, at least one of said flexible tubes is a floating tube having at least one free floating end.

16. The support arm of claim 15 wherein at least one of said plurality of flexible tubes includes a core, a casing surrounding said core in a spaced relationship to define a void between said core and said casing, and a filling material substantially filling said void.

17. The support arm of claim 14 wherein said first arm segment is connected to said second arm segment by a first joint, said first joint permit pivotal movement between said first arm segment and said second arm segment in at least one direction.

18. The support arm of claim 17 wherein said second arm segment is connected to said component mount by a second joint, said second joint permit pivotal movement between said first arm segment and said second arm segment in at least one direction.

19. The support arm of claim 18 wherein said flexible arm segment is further defined as said second arm segment.

20. The support arm of claim 19 wherein said fixed tube and said floating tube are vertically offset from one another.

21. The support arm of claim 13 further comprising a third arm segment, a fourth arm segment and a second component mount; and

wherein said second third arm segment, said fourth arm segment and said second component mount are connected to said base and to one another to provide a support for a second component.

22. A support arm comprising:  
a mounting base;

a flexible arm segment mounted to said base, said flexible arm segment including a plurality of discrete flexible tubes extending substantially parallel to one another; and

a component mount connected to said arm segment.

23. The support arm of claim 22 wherein each of said plurality of flexible tubes includes a first end and a second end, at least one of said flexible tubes is a fixed tube including a fixed first end and a fixed second end, at least one of said flexible tubes is a floating tube having at least one free floating end.

24. The support arm of claim 23 wherein at least one of said plurality of flexible tubes includes a core, a casing surrounding said core in a spaced relationship to define a void between said core and said casing, and a filling material substantially filling said void.

25. A support arm comprising:

a mounting base;

a flexible arm segment mounted to said base, said flexible arm segment including a core, a casing surrounding said core in a spaced relationship to define a void between said core and said casing, and a filling material substantially filling said void; and

a component mount connected to said arm segment.

26. The support arm of claim 25 wherein said flexible arm segment includes a plurality of discrete flexible tubes extending substantially parallel to one another.

27. The support arm of claim 26 wherein each of said plurality of flexible tubes includes a first end and a second end, at least one of said flexible tubes is a fixed tube including a fixed first end and a fixed second end, at least one of said flexible tubes is a floating tube having at least one free floating end.

\* \* \* \* \*