

No. 676,486.

Patented June 18, 1901.

M. L. BEAVER.

RECEPTACLE FOR ICE CREAM BRICKS, WATER ICES, OR THE LIKE.

(Application filed Dec. 27, 1900.)

(No Model.)

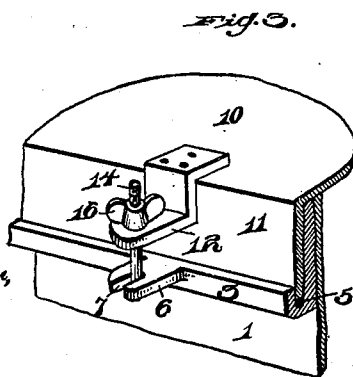
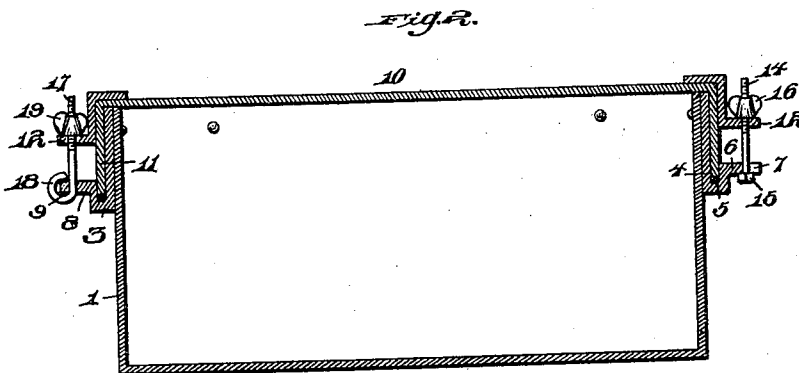
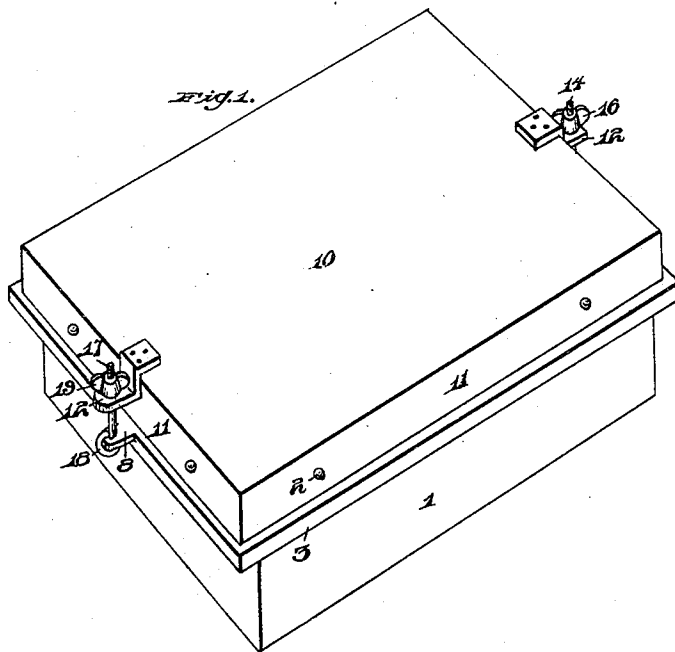

Witnesses:  
*J. P. Appleman,*  
*M. Hunter*

Inventor  
*Michael L. Beaver*  
BY  
*O. L. Lewis*  
J.E.W.

# UNITED STATES PATENT OFFICE.

MICHAEL L. BEAVER, OF PITTSBURG, PENNSYLVANIA, ASSIGNOR OF ONE-HALF TO GEORGE W. REED, OF SAME PLACE.

RECEPTACLE FOR ICE-CREAM BRICKS, WATER-ICES, OR THE LIKE.

SPECIFICATION forming part of Letters Patent No. 676,486, dated June 18, 1901.

Application filed December 27, 1900. Serial No. 41,212. (No model.)

*To all whom it may concern:*

Be it known that I, MICHAEL L. BEAVER, a citizen of the United States of America, residing at Pittsburg, in the county of Allegheny and State of Pennsylvania, have invented certain new and useful Improvements in Receptacles for Ice-Cream Bricks, Water-Ices, or the Like; and I do hereby declare the following to be a full, clear, and exact description thereof, reference being had to the accompanying drawings, which form a part of this specification.

This invention relates to certain new and useful improvements in receptacles for ice-cream bricks, water-ices, and the like, and has for one object the provision of novel means to provide a receptacle wherein the same may be easily stored and retained without any liability of leakage taking place.

The present invention further aims to construct a receptacle of the above-described class wherein a hermetically-sealing top is provided that may be easily secured and removed when desired.

A still further object of the invention resides in the fact that by providing an airtight receptacle for the ices the same will be retained in better condition for a longer period of time than would otherwise be the case.

The invention also contemplates to construct a device of the above-described class that will be extremely simple, strong, durable, and comparatively inexpensive to manufacture.

With the above and other objects in view the invention consists in the novel combination and arrangement of parts to be herein-after more fully described, and specifically pointed out in the claims.

In describing the invention in detail reference is had to the accompanying drawings, forming a part of this specification, and wherein like numerals of reference indicate corresponding parts throughout the several views, in which—

Figure 1 is a perspective view of my improved receptacle. Fig. 2 is vertical sectional view thereof. Fig. 3 is a perspective view of a portion of the side, showing in detail the fastening means employed.

In the drawings the reference-numeral 1 indicates the lower receptacle, which is rectangular in form and has rigidly secured thereto by means of rivets 2 an outwardly-extending flange 3, said outwardly-extending flange 3 having formed therein a recess 4, the latter being provided with a gasket or packing 5. Formed integral with said outwardly-extending flange 3 on one side of the receptacle is secured a lug 6, said lug having formed therein a U-shaped recess 7. Upon the opposite side of the receptacle, arranged above the flange 3, is a similar lug 8, said lug being apertured, as shown at 9. The reference-numeral 10 indicates the cover, having downwardly-extending flanges 11, said cover being provided with apertured lugs 12 for the reception of a screw-threaded bolt 14, carrying a head 15, said bolt being arranged in the U-shaped opening 7, carrying on its other end a thumb-nut 16. The reference-numeral 17 indicates a screw-threaded bolt on the opposite side of the receptacle extending through the lugs 12 8 and seated in the aperture 9. This bolt terminates at its lower end into a loop 18, forming a swiveled connection. Said bolt is likewise provided with a thumb-nut 19 of the screw-threaded portion.

When it is desired to open the receptacle, the thumb-nut 16 is removed and the corresponding thumb-nut 19 loosened, allowing the lid or cover to be raised from one side, and the loop 18 of the bolt 17 will act as a hinge connection, as will be readily understood from the foregoing description, taken in connection with the accompanying drawings.

It will be noted that various changes may be made in the details of construction without departing from the general spirit of my invention.

Having thus fully described my invention, what I claim as new, and desire to secure by Letters Patent, is—

1. In a device of the character described, a receptacle, recessed flanges secured thereto, lugs carried by the flanges, a packing secured in said recess, a cover adapted to fit within said recess, Z-shaped apertured lugs carried by the cover, and means connecting the cover and receptacle whereby the cover may be

raised without being wholly disengaged from the receptacle, substantially as described.

2. In a device of the character described, a receptacle, recessed flanges secured thereto, 5 lugs carried by said flanges, a cover adapted to fit within said recess, Z-shaped apertured lugs secured to said cover, a swiveled connection between the cover and receptacle at one end and locking means at the opposite 10 end, substantially as described.

3. In a device of the character described, a receptacle, recessed flanges secured thereto, an apertured lug on one end of said flange, a 15 cover, apertured Z-shaped lugs secured to said cover, a threaded bolt provided with an

eye engaging the aperture in said first-named flange of the receptacle and the apertured lug of the cover, and a bolt engaging the slotted lug on the opposite side of the receptacle 20 and the apertured lug of said cover, whereby the first-named connection will act as a hinge when the nut of the bolt is partly unscrewed and the bolt on the other end wholly disengaged, substantially as described. 25

In testimony whereof I have hereunto affixed my signature in the presence of two subscribing witnesses.

MICHAEL L. BEAVER.

Witnesses:

JOHN GROETZINGER,  
M. HUNTER.