

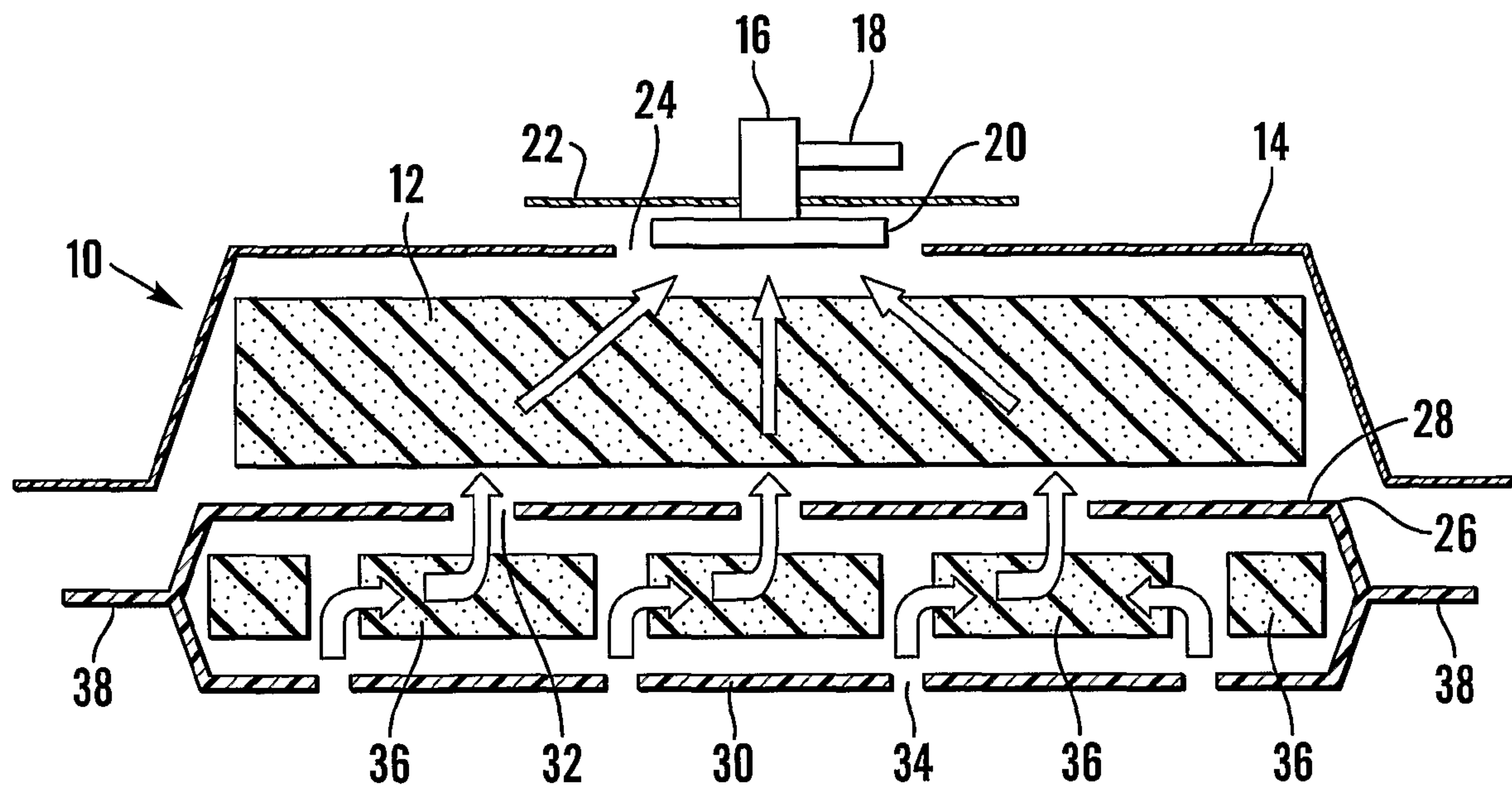

(86) Date de dépôt PCT/PCT Filing Date: 2001/05/09
 (87) Date publication PCT/PCT Publication Date: 2001/11/15
 (45) Date de délivrance/Issue Date: 2007/09/25
 (85) Entrée phase nationale/National Entry: 2002/11/07
 (86) N° demande PCT/PCT Application No.: GB 2001/002035
 (87) N° publication PCT/PCT Publication No.: 2001/085248
 (30) Priorité/Priority: 2000/05/09 (GB0011202.9)

(51) Cl.Int./Int.Cl. *A61M 27/00* (2006.01),
A61M 1/00 (2006.01)
 (72) Inventeurs/Inventors:
HUNT, KENNETH WILLIAM, GB;
HEATON, KEITH PATRICK, GB;
SCHROEDER, WAYNE J., US
 (73) Propriétaire/Owner:
KCI LICENSING, INC., US
 (74) Agent: CASSAN MACLEAN

(54) Titre : PANSEMENT ABDOMINAL
 (54) Title: ABDOMINAL WOUND DRESSING



(57) **Abrégé/Abstract:**

A system and method for the temporary closure of a wound, especially an abdominal wound, to facilitate re-entry, final closure, and long term healing of the wound. An abdominal wound dressing and methods of use are described that enable the application of negative pressure to the wound site in a site healing promoting manner while also limiting the formation of adhesions that would prevent the removal of the dressing. The dressing comprises a layer of porous foam material (36) enclosed by sheets of elastomeric material (38) punctuated by a number of appropriately placed holes (34). Multiple layers of porous foam may also be used. A suction tube connector (16) is provided on an upper surface of a layer of foam (12) for connection to a negative pressure source. At least one layer of foam is enclosed in elastomeric material and is placed in direct contact with the tissue within the open wound. Fluids are drawn by negative pressure through the holes positioned in the elastomeric envelope, and through the foam. If multiple foam layers are employed, the lower layer(s) of foam are of a finer porosity while the upper layer of foam is coarse. An adhesive elastomeric sheet (14) covers the entire wound dressing and seals the edges to the skin surrounding the wound. An appropriate vacuum device is attached to the suction tube connector.

(12) INTERNATIONAL APPLICATION PUBLISHED UNDER THE PATENT COOPERATION TREATY (PCT)

(19) World Intellectual Property Organization
International Bureau(43) International Publication Date
15 November 2001 (15.11.2001)

PCT

(10) International Publication Number
WO 01/85248 A1

- (51) International Patent Classification⁷: **A61M 27/00**,
1/00, A61F 13/02, A61B 19/10 [GB/GB]; 33 Hermitage Road, Poole, Dorset BH14 0QG (GB).
- (21) International Application Number: PCT/GB01/02035 (74) Agents: **WOODCRAFT, David, Charles** et al.; Brookes Batchellor, 102-108 Clerkenwell Road, London EC1M 5SA (GB).
- (22) International Filing Date: 9 May 2001 (09.05.2001)
- (25) Filing Language: English (81) Designated States (*national*): AE, AG, AL, AM, AT, AU, AZ, BA, BB, BG, BR, BY, BZ, CA, CH, CN, CR, CU, CZ, DE, DK, DM, DZ, EE, ES, FI, GB, GD, GE, GH, GM, HR, HU, ID, IL, IN, IS, JP, KE, KG, KP, KR, KZ, LC, LK, LR, LS, LT, LU, LV, MA, MD, MG, MK, MN, MW, MX, MZ, NO, NZ, PL, PT, RO, RU, SD, SE, SG, SI, SK, SL, TJ, TM, TR, TT, TZ, UA, UG, US, UZ, VN, YU, ZA, ZW.
- (26) Publication Language: English (84) Designated States (*regional*): ARIPO patent (GH, GM, KE, LS, MW, MZ, SD, SL, SZ, TZ, UG, ZW), Eurasian patent (AM, AZ, BY, KG, KZ, MD, RU, TJ, TM), European patent (AT, BE, CH, CY, DE, DK, ES, FI, FR, GB, GR, IE, IT, LU, MC, NL, PT, SE, TR), OAPI patent (BF, BJ, CF, CG, CI, CM, GA, GN, GW, ML, MR, NE, SN, TD, TG).
- (30) Priority Data: 0011202.9 9 May 2000 (09.05.2000) GB
- (71) Applicant (*for all designated States except US*): **KCI LICENSING, INC.** [US/US]; 8023 Vantage Drive, San Antonio, TX 78230-4726 (US).
- (72) Inventors; and (75) Inventors/Applicants (*for US only*): **HUNT, Kenneth, William** [GB/GB]; 18 Egdon Drive, Merley, Wimborne, Dorset BH21 1TY (GB). **HEATON, Keith, Patrick**
- Published:
— with international search report

[Continued on next page]

(54) Title: ABDOMINAL WOUND DRESSING

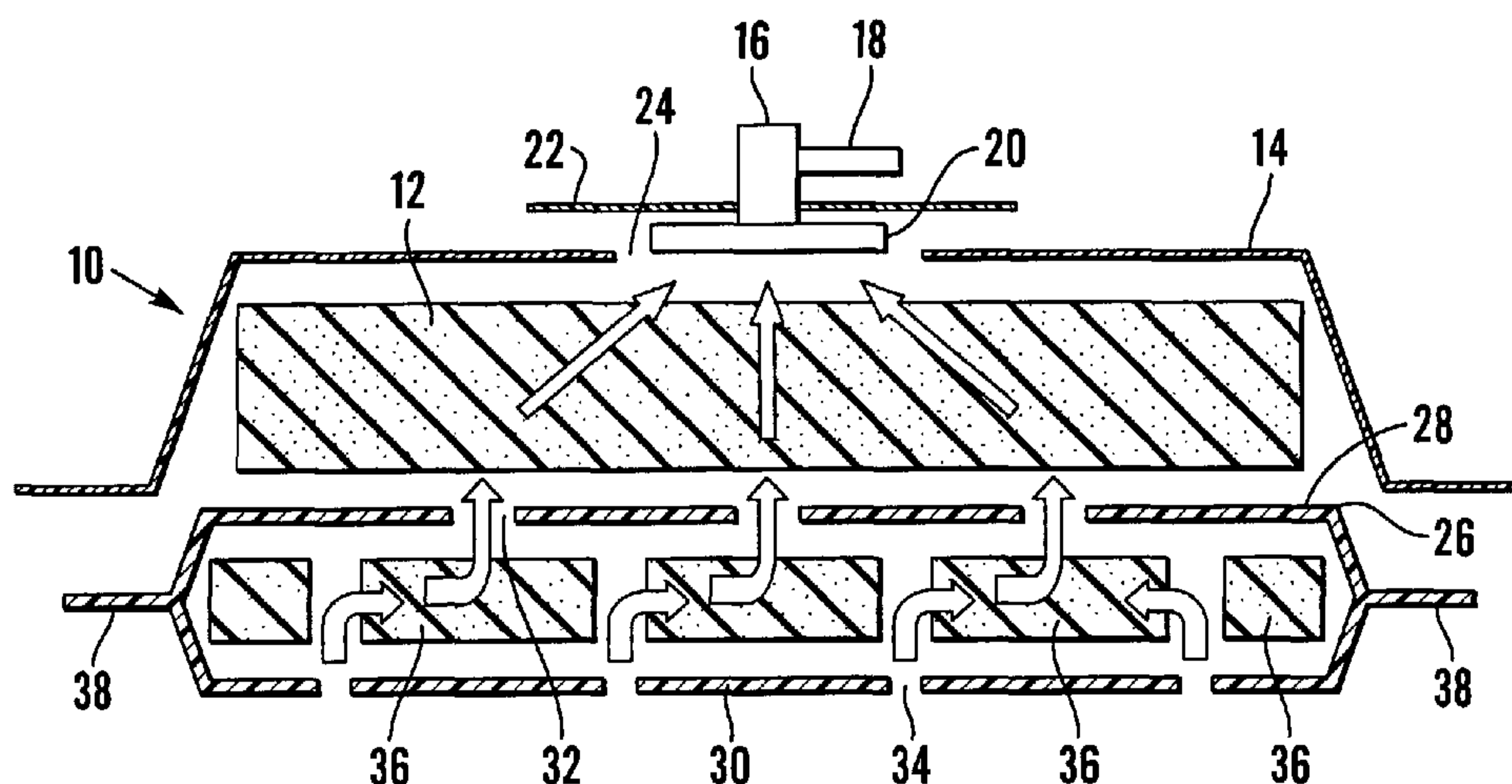

(57) **Abstract:** A system and method for the temporary closure of a wound, especially an abdominal wound, to facilitate re-entry, final closure, and long term healing of the wound. An abdominal wound dressing and methods of use are described that enable the application of negative pressure to the wound site in a site healing promoting manner while also limiting the formation of adhesions that would prevent the removal of the dressing. The dressing comprises a layer of porous foam material (36) enclosed by sheets of elastomeric material (38) punctuated by a number of appropriately placed holes (34). Multiple layers of porous foam may also be used. A suction tube connector (16) is provided on an upper surface of a layer of foam (12) for connection to a negative pressure source. At least one layer of foam is enclosed in elastomeric material and is placed in direct contact with the tissue within the open wound. Fluids are drawn by negative pressure through the holes positioned in the elastomeric envelope, and through the foam. If multiple foam layers are employed, the lower layer(s) of foam are of a finer porosity while the upper layer of foam is coarse. An adhesive elastomeric sheet (14) covers the entire wound dressing and seals the edges to the skin surrounding the wound. An appropriate vacuum device is attached to the suction tube connector.



WO 01/85248 A1

WO 01/85248 A1



— *before the expiration of the time limit for amending the claims and to be republished in the event of receipt of amendments*

For two-letter codes and other abbreviations, refer to the "Guidance Notes on Codes and Abbreviations" appearing at the beginning of each regular issue of the PCT Gazette.

Abdominal Wound Dressing

This invention relates generally to methods and devices used for healing wounds caused by injury or surgery. More specifically, this invention relates to methods and devices for facilitating the healing of open wounds such as abdominal wounds that benefit from temporary closure and later reopening before final closure.

Significant advances have been made in preventing post-operative infections. Still, post-operative treatment of patients receiving many types of invasive surgeries, especially those involving the abdominal cavity, is enhanced by the ability to re-enter the cavity in order to address peritonitis and other infections that often inhibit the final healing of the wound and the internal organs. While the optimum outcome is no post-operative infections or other complications whatsoever, such complications occur frequently. Their occurrence has led to the now common practice of establishing a temporary wound closure and, later, re-entering the wound for the purposes of cleansing the abdominal cavity, and for treating such complications, which must be treated before final, or definitive, closure.

The background description in U.S. Patent No.5,437,683 issued to Neumann et al, entitled Surgical Closure, reviews various complications associated with abdominal surgery and the process of post-operative cleansing of the abdominal cavity. Neumann et al teaches a somewhat complex solution to establishing a re-enterable wound closure, namely, a flexible fabric or plate like securing device that covers the wound, provides a suction tube, and extends outward into a larger, sealable tube that may be re-entered as needed before final closure.

Many other techniques for post-operative temporary wall closure after abdominal surgery have been described. Studying these techniques enables the establishment for objective criteria by which to judge the suitability of various proposed temporary closure modalities.

A suitable temporary closure should be simple, easy to apply, effective in containing the abdominal contents unimally interfere with the abdominal organs and

surrounding tissue, minimally, if at all, promote the formation of adhesions and fistula, and promote process towards definitive closure.

A problem common to many existing methods of temporary wound closure is adhesion formation between the tissue and the material in contact with the wound. Such adhesions are undesirable, and complicate the process of preparing the wound site for final closure. Placing porous materials such as gauze, surgical towels and even open cell foam, in direct contact with the open wound site, further complicates final closure by providing increased surface area that promotes adhesion formation, thereby making removing this material even more difficult.

Maintaining negative pressure on a wound site without creating conditions that make the removal of the temporary wound covering material more difficult, is manifestly beneficial. A desirable layered wound covering permits both the application of negative pressure, and the resultant removal of exuded fluids. Such a covering is re-enterable for the purpose of cleansing the wound without trauma to the wound site. Such a wound covering would be most advantageous for open abdomen surgical wounds. These devices and techniques could also be used on other types of open wounds that present a difficult healing process.

The need for a wound covering, and therapeutic treatment system that allows the application of therapeutic negative pressure without causing increased adverse side effects to the open wound site is apparent. Presently, no such wound covering, or treatment system is known to exist. It is towards the filling of this need that the present invention is directed.

An object of the present invention is to provide a layered wound dressing that serves as a temporary covering for an open wound and permits the application of negative pressure for the removal of exuded fluids from the wound.

A further object of the present invention to provide a wound dressing that permits the application of negative pressure for the removal of fluids from the wound site in a manner that facilitates the healing of the wound, and minimizes adhesion formation between the wound dressing and the underlying tissue.

- 3 -

Another object of the present invention is to provide a wound dressing that permits the application of negative pressure for the removal of fluids from the wound site in a manner that does not promote the formation of adhesions between the wound dressing and the underlying tissue and yet provides a porous medium through which the exuded fluids may pass without experiencing excessive blockage that would degrade the effectiveness of the negative pressure.

A still further object of the present invention is to provide an abdominal wound dressing that serves as a temporary covering for an open abdominal wound and permits the application of negative pressure for the removal of exuded fluids from the wound while being easily retracted from the wound site for the purpose of permitting repeated access to the abdominal cavity for cleansing and/or treatment.

In fulfilment of these and other objectives the present invention provides an abdominal wound dressing and methods for its use that permit the application of negative pressure to the wound site in a manner that promotes the healing of the site while limiting the formation of adhesions that would prevent the removal of the dressing.

According to one aspect of the present invention there is provided a removable wound closure which comprises a porous pad which is permeable to liquids for placement on or in a wound, the porous pad comprising a polymer foam having interconnecting cells and a sheet of flexible plastics film having a plurality of holes in its surface, the plastics film being in contact with a surface of the porous pad so that in use, the plastics film is disposed between the surface of the wound and the pad, a film drape which is impermeable to liquids for placement over the porous pad, the film drape having an adhesive perimeter for sealing to an area of skin surrounding the wound and connection means extending through the film drape and in flow communication with the porous pad for connection to a source of negative pressure for stimulating a flow of exuded liquids from the wound.

According to another aspect of the invention, there is provided a removable wound closure comprising a porous pad, a film drape, and a connection means. The porous pad is permeable to fluids for placement on or in a wound, and has a polymer foam layer and a first

- 3a -

sheet of flexible film. The polymer foam layer has interconnecting cells. The first sheet of flexible film has a plurality of holes distributed over its surface; it is in contact with a surface of the foam layer so that in use, it is disposed between, and in contact with both of, the surface of the wound and the foam layer; it comprises an elastomeric film or a flexible plastics film, whereby it is resistant to the formation of adhesions with the wound and is thereby easily removable from the wound. The film drape is impermeable to liquids and is for placement over the porous pad; it has an adhesive perimeter for sealing to an area of skin surrounding the wound. The connection means extends through the film drape and is in flow communication with the porous pad for connection to a source of negative pressure for stimulating a flow of exuded fluids from the wound.

In a further aspect of the invention, the preceding exemplary embodiment is provided with a second sheet of flexible film disposed between the film drape and the porous pad. The second sheet of flexible film is sealed to the first sheet of flexible film around their respective perimeters to form an envelope. The second sheet of flexible film is formed with holes so that when the connection means is connected to a source of negative pressure, wound exudate is drawn through the porous pad and out of the porous pad through the holes in the second sheet of flexible film.

According to yet another aspect of the invention, there is provided a removable wound dressing, especially as would be applied to a large open wound that requires the drainage of fluid therefrom. The dressing comprises a first porous pad, a film drape, and a tube connector. The first porous pad is permeable to fluids and is for placement in contact with the wound; it has a foam pad and an elastomeric envelope. The foam pad comprises a polymer based foam having interconnecting cells and has a plurality of dispersed transverse holes. The elastomeric envelope comprises first and second sheets of elastomeric film sealed at their periphery and enclosing the foam pad. Each of the first and second sheets of elastomeric film have a plurality of dispersed holes therein. The film drape is impermeable to fluids and is for placement over the first porous pad; it has an adhesive perimeter for adhering the film drape to an area of skin surrounding the

- 3b -

wound when the first porous pad is placed in contact with the wound. The tube connector is positioned through the film drape and in flow communication with the first porous pad; it is for connection to a source of negative pressure for initiating a flow of exuded fluids from the wound.

According to even yet another aspect of the invention, there is provided a removable wound dressing, especially as would be applied to a large open wound that requires the drainage of fluid therefrom. The dressing comprises a first porous pad, a second porous pad, a film drape, and a tubular connector. The first porous pad is permeable to fluids and is for placement in contact with the wound; it comprises a foam pad and an elastomeric envelope. The foam pad comprises a polymer based foam having interconnecting cells and has a plurality of dispersed transverse holes. The elastomeric envelope comprises first and second sheets of elastomeric film, sealed at their periphery, and enclosing the foam pad. The first sheet of elastomeric film has a plurality of dispersed holes therein which are offset from alignment with the dispersed holes in the foam pad. The second sheet of elastomeric film also has a plurality of dispersed holes therein which are aligned with the dispersed holes in the foam pad. The second porous pad is also permeable to fluids and is for placement over, and in contact with, the first porous pad; it also comprises a polymer foam having interconnecting cells. The film drape is impermeable to fluids and is for placement over the second porous pad and the first porous pad placed over the wound. The film drape has an adhesive perimeter for adhering it to an area of skin surrounding the wound. The tubular connector is positioned through the film drape and in flow communication with the second porous pad, for connection to a source of negative pressure for initiating a flow of exuded fluids from the wound.

The holes in the flexible plastics film should constitute a sufficiently small proportion of the area of the film in contact with the wound so that there is limited

ingrowth of fibrous tissue into the sheet. In this way, the film does not become adhered to the wound but remains relatively easy to remove. Preferably, the holes in the film should constitute less than 10%, especially less than 5% or even 1 to 2% or less of the effective area of the film. Openings in the form of slits or slots are preferred because these constitute a very small proportion of the area of the film.

The slits or slots may typically be 0.5 to 2 cms, e.g. 1 to 1.5 cm in length and may be aligned in rows and separated by 10 to 40 mil spaces, e.g., 20 to 30 mil spaces.

The flexible film should be sufficiently stiff to hold its shape. A suitable material is plasticised pvc of 30 to 80 microns in thickness, e.g., 40 to 60 microns.

In use, the film is trimmed to size such that it overlaps the wound edge. An absorbent polymer foam, e.g. a reticulated polyurethane foam, is trimmed to size so that it fits within the boundary of the wound. The trimmed foam pad is placed on the cut film so that the edges of the film extend beyond the perimeter of the foam, e.g. by about 20 to 80 mm, preferably 40 to 60 mm, typically about 50 mm. A surgical drape of elastomeric film-like material is placed over the foam pad and the flexible plastics film so as to encapsulate and provide an air-tight seal over the wound dressing. A suction tube or connector is arranged to extend through the surgical drape into the polymer foam or into close proximity with it. The suction tube or connector is sealed to the surgical drape so that the space beneath the drape can be maintained at a pressure below atmospheric by connecting the suction tube or connector to a source of negative pressure. A preferred suction tube connector head is described in GB Patent No. 2329127 and in US Patent No. 6216701.

Surgical drapes conventionally comprise a thin elastomeric film which is coated overall on one side with a tacky, pressure-sensitive adhesive. Usually a protective sheet which is treated with a release agent contacts the adhesive surface and is stripped away just before use to reveal the adhesive surface. For the purposes of this invention, the assembly of the adhesive elastomeric film and protective film are cut to size (and if

appropriate, a hole cut for the suction tube or connector) prior to stripping away the protective sheet.

Suitable elastomeric films include polyurethane and polybutadiene. Commercially available surgical drapes include those marketed by the 3M Company under the trade mark "Tegaderm".

The foam may comprise multiple layers. A suction tube spigot or connector is provided on the upper surface of foam for connection to a negative pressure source. Instead of employing a flexible plastics sheet in contact with the wound and a separate portion of polymer foam, the foam may be enclosed in an envelope of plastics film. In this embodiment, the plastics film may be elastomeric in nature and the film need not extend beyond the perimeter of the foam. However, it is convenient to provide a flange of film extending beyond the perimeter of the foam, e.g. by about 20 to 80 mm, more usually about 40 to 60 mm, typically about 50 mm. Suitable elastomeric film materials include polyurethane, PTFE, or polybutadiene films, similar to those used for surgical drapes. Preferably, the elastomeric film has a thickness of about 30 to 70 microns, especially 40 to 60 microns, typically about 50 microns. A number of differently sized polymer foam slabs will be cut, shaped and enclosed in an envelope of elastomeric film material. It may be convenient to weld the film to form the envelope using ultrasonic or heat welding. Commonly, abdominal wounds are approximately elliptical in shape and the foam pad is also preferably elliptical in shape. Typical sizes for the foam pads may be about 280, 320 and 380 mm for the major dimension and about 140, 175 and 250 mm for the minor dimension. A polyurethane foam having a thickness of about 5 to 10 mm, e.g. about 6 mm, is suitable. Polyurethane foams having a pore size of about 30 to 50, e.g. 40 pores per inch are preferred. Polyether foams or polyvinyl alcohol foams may alternatively be used. If multiple layers of foam are employed, different foams may be used in different layers. For example, the layer in contact with the lower film may be of polyvinyl alcohol foam and the upper foam layer(s) may be of polyurethane.

In the multi-layer embodiment, at least one lower layer of foam may be enclosed in elastomeric material and placed in direct contact with the tissue within the open wound. In another embodiment, only a single layer of foam is used, and the envelope of elastomeric material containing the layer of foam is placed in direct contact with the open wound.

Fluids are drawn by negative pressure through the holes in the flexible or elastomeric material, and then through the foam. In the multi layer embodiment, fluids are drawn by negative pressure through the holes located in the elastomeric envelope, through the lower layer(s) of foam, again through holes in the elastomeric envelope, and then through the upper layer of foam that is placed over the enveloped lower layer(s).

In the multi layer embodiment, the lower layer(s) of foam may be of a finer porosity while the upper layer of foam may be coarser. In all embodiments of the present invention, an adhesive elastomeric sheet, e.g. a surgical drape, covers the entire wound dressing and seals the edges to the skin surrounding the wound. An appropriate vacuum device is attached to the suction tube spigot or connector to provide therapeutic negative pressure.

Figure 1 is a cross sectional view of the device of a first embodiment of the present invention showing the use of a combination single foam layer within an envelope and an overlay of a second foam layer.

Figure 2 is a cross sectional view of a second embodiment of the present invention similar to Figure 1 but showing the use of a double foam layer within an envelope.

Figure 3 is a third embodiment comprising a flexible sheet and a layer of foam thereon.

The present invention lends itself to use in conjunction with surgical techniques that require repeated access to the abdominal cavity after surgery therein. The present invention is directed toward providing a removable and beneficial dressing that facilitates both healing of the wound and its final closure.

Reference is made to U.S. Patent Application Serial No. 08/951,832 and also to USSN 09/078,223 and GB Patent No. 2307180 (WO 94/20041 and WO 97/18007), for a description of a negative pressure system suitable for implementing the vacuum required for use of the dressing structures, and treatment method, described herein. Negative pressure is defined herein as a vacuum of less than 1 atmosphere of pressure. Controlling the negative pressure and collecting and disposing of exuded fluids are also described in the above cited references. The manner of using such systems in conjunction with the dressing structure described herein will become apparent to those of ordinary skill in the art.

Reference is made to Figure 1 for a description of a first embodiment of the present invention wherein a single lower layer of foam is utilized in the wound contact layer of the dressing. Both Figure 1 and Figure 2 are partially exploded views of the dressing of the present invention. During use, the layers of foam and the intervening sheets of elastomeric material would be in close and sometimes sealed contact with each other.

The complete wound dressing 10 shown in Figure 1 comprises upper foam layer 12 and lower foam layer 36. Lower foam layer 36 is enveloped within two sheets of elastomeric material 38 such as are used for the membranes of surgical drapes. The elastomeric sheets 38 may preferably be constructed from polyurethane film, which provides both the necessary strength and resiliency needed for placement in direct contact with the wound. Another suitable material is polytetrafluoroethylene (PTFE). Elastomeric sheets 38 are sealed on their periphery, e.g. by welding or adhesive, in a manner that surrounds the lower layer of foam 36. Elastomeric sheets 38 resist the formation of wound adhesions and are therefore appropriate for placement in direct contact with the tissue surfaces within the wound and around the wound periphery.

Placing such non-porous film material in contact with the wound opening, rather than open cell foam or a mesh material greatly reduces the occurrence of adhesions that, over time would make removal of the dressing difficult or dangerous. The

pliable and flexible lower layer envelope is easily inserted over and/or into the wound. The lower layer envelope may, as desired, be placed either over the wound wherein the edges of the layer are in contact with the skin surrounding the wound or preferably into the wound leaving the upper surface of the upper surface of the lower layer envelope exposed above the wound.

The overall dressing 10 has a generally flat profile as shown in cross section in Figure 2 and Figure 3. The shape of the dressing can vary significantly depending on the size and shape of the wound to which it is to be applied. A rectangular or square shape having dimensions on the order of 8 inches by 8 inches up to as much as 18 inches by 18 inches might be appropriate for use in conjunction with the abdominal wounds described above. Other dimensions and shapes, such as circular, oval or even oblong may be suitable for other types of wounds. Typical dimensions for thicknesses and for planar dimensions of oval or elliptical foam slabs are given above. This basic structure may be easily implemented with any of these, or even other, shapes and sizes.

Elastomeric sheets 38 are provided with a plurality of holes 32 and 34 in the upper and lower walls 28 and 30 of the envelope they define. These holes may be of the order of 3 mm (1/8 inch) to 6 mm (1/4 inch) in length, diameter or maximum dimension and may be dispersed across the surface of the defined envelope on 25 to 75 mm (1 inch to 3 inch) centres. Preferably, the holes are slit- or slot-shaped. The positions of the holes may be associated with holes positioned into and through lower foam layer 36 as described in more detail below. Where holes are provided in the foam, they may be of different sizes and shapes.

Lower foam layer 36 is preferably constructed from polyurethane having a high degree of reticulation and good permeability under suction. Foams having at least 90% and preferably 95% of interconnecting cells are preferred. Preferably, the foams have from 20 to 60 pores per inch. Preferably, the polyurethane foams are prepared by reacting a hydrophilic polyether polyol with a tolylene diisocyanate in the presence of water. Carbon dioxide is liberated in the reaction which provides a gaseous blowing

- 9 -

agent. Pore size can be controlled by temperature and stirring. Reticulation is enhanced by maintaining the foam in the chamber in which the foam is initially formed and causing
5 the blowing agent to expand further and rupturing cell walls.

As indicated above, lower foam layer 36 is punctuated by a plurality of holes that pass entirely through the layer from its upper to lower surface. As will be seen from their placement with respect to holes 32 and 34 in the elastomeric envelope, the holes in the lower foam layer 36 are provided to form "sinks" into which the exuded fluids from the
10 wound may be drawn. Holes 34 in the lower surface of the elastomeric envelope 38 may be positioned directly over the holes in the foam layer 36.

Holes 32 in the upper wall 28 of the elastomeric envelope 38 are preferably positioned so that they are not aligned with the holes in the foam layer 36 and the holes in the lower surface 30 of the envelope 38. In this manner, fluids are withdrawn (by
15 appropriate negative pressure) from the wound into the holes 34 positioned in the lower surface 30 of the envelope 38 and into the "sink" holes in the lower foam layer 36. The fluids are then drawn into the cells of the lower foam layer 36 where they are dispersed before again being drawn through holes in the elastomeric envelope 38, this time in the upper wall 28 of the envelope 38. Placement of the lower foam layer/envelope onto or
20 into the wound therefore requires proper orientation of the holes as shown.

A problem encountered in the prior art has been the deterioration of flow caused by the clogging of the medium through which the exuded fluids, and the accompanying debris, must flow. Such flows are drawn towards the source of the negative pressure thus becoming clogged most quickly along the direct path towards the vacuum source, in this
25 case the suction tube. The present invention disperses the vacuum so as to de-localize the flow. The layers of foam and the spaced holes in the elastomeric sheets provide this dispersion. Even without an interleaved layer of foam, the offset holes accomplish this purpose. The dark arrows in both Figure 1 and Figure 2 show the flow of exuded fluid through the dressing.

30

- 10 -

Upper foam layer 12 provides the initial mechanism for dispersing the vacuum
5 that draws the fluids up from the wound. In the presently preferred embodiment as
shown in Figure 1, upper foam layer 12 is a coarser polyester-based or polyurethane foam
having greater rigidity than the lower layer of polyurethane foam. For example, the
lower layer of foam 36 may have about 1.5 to 2 times the pores per inch of the coarser
foam layer. Typically, the coarse layer of foam may have 20 to 30 pores per inch. Upper
10 foam layer 12 should be somewhat less pliable so as to hold its shape under the influence
of even relatively strong negative pressure. Upper foam layer 12 is placed in direct
contact with the upper wall 28 of the elastomeric envelope 38 containing lower foam
layer 36. Covering upper foam layer 12 and the balance of the dressing is elastomeric
drape 14, which in the preferred embodiment is made of the same type of polyurethane
15 film, as is elastomeric envelope 38.

Drape 14 is a single sheet, cut large enough to fully cover upper foam layer 12
and an additional area of skin surrounding the wound site. A pressure sensitive adhesive,
such as a permanently tacky acrylic adhesive, is coated on at least the periphery of drape
14 for creating an airtight seal against the skin, effectively closing the dressing and the
20 wound beneath it.

Connector 16 is positioned over a hole cut in drape 14 and is fixed thereto by
sealing patch 22. Sealing patch 22, which is circular in the preferred embodiment,
adheres to a bottom flange portion 20 of connector 16 as well as drape 14. In this
manner, a negative pressure is drawn in upper foam layer 12 when an appropriate such
25 line is attached to tube connector 18 positioned on connector 16. Flange portion 20 may
have a lower surface shaped with channels to direct flow of fluid from the porous pad to
the tubular portion 18 of the connector 16. A suitable suction head connector is shown in
GB 2329127 and in US 6216701 (WO 99/13793).

Another embodiment of the present invention is depicted in Figure 3. In this
30 embodiment, the principles of operation are identical, but the dressing is comprised of
but a single foam layer, the foam layer within the non-porous film is dispensed with.

The foam utilized is black coloured open cell polyurethane currently commercialised in assignee's V.A.C. product.

Referring to Figure 3, a flexible sheet 38 of semi-stiff plastics material, e.g. formed from plasticised pvc is placed in contact with the wound so that the trimmed edges line the walls of the wound. The sheet is formed with holes 34 which are preferably slits or narrow slots. A reticulated plastics foam is placed on top of the sheet 38. A suction head connector 16 is placed with its flange portion 20 in contact with the top surface of the foam pad and a surgical drape 14 is placed over the foam and the sheet 38 to seal the dressing in the wound.

Instead of providing a separate sealing patch 22 to seal the connector to the dressing, the patch may be part of the surgical drape, as described and illustrated in GB 2,329,127 and US 6216701.

The dressing structure of the present invention could be applied in a number of circumstances in association with a variety of different wound types. In the case of an open abdominal wound as might result from surgery, the lower foam layer contained within the elastomeric envelope would be positioned within the wound with the periphery possibly extending under the fascia and peritoneum of the abdominal wall. The upper foam layer could then be cut to a size appropriate for positioning on the exposed upper surface of the lower layer envelope. The drape with the appropriately positioned spigot may then be placed over the upper foam layer and the wound as a whole, extending two or more inches over the skin surrounding the wound, and adhesively holding the dressing in place. Application of a suction line as described above draws the entire dressing onto the wound and serves to initiate the flow of effluent through the dressing.

The thickness of the upper and lower foam layers is determined in part by the desire to have a flat profile to the dressing when it is in place. The more rigid upper layer of foam may, in the preferred embodiment, have a thickness on the order of 25 to 75 mm (1 inch to -3 inches) uncompressed. Its rigidity should limit compression to 80% - 90% under the negative pressures normally associated with wound suction and

the like. The more pliable lower foam layer, where employed, should have a thickness on the order of 5 to 15 mm, e.g. 5 to 10 mm (about $\frac{1}{4}$ to $\frac{3}{4}$ inch) so as to be capable of being easily inserted into the wound.

The structure of the present invention may likewise be utilized on the surface of the skin when the open wound is not associated with an internal cavity or the like. In such a case the periphery of the elastomeric lower envelope may contact the skin surrounding the wound. This is appropriate as long as the periphery of the drape covering the upper foam layer extends suitably beyond the lower envelope to adhere to the skin and seal the dressing. It therefore becomes apparent that the lower elastomeric envelope may be pre-made in a variety of shapes and sizes while the upper foam layer and the drape may be cut, at the time the dressing is placed on the wound, to the appropriate size and configuration.

Figure 2 discloses an alternate preferred embodiment of the present invention wherein the single lower layer of foam shown in Figure 1 is replaced with a double layer of foam. In this embodiment, elastomeric envelope 38 encloses a first lower foam layer 40 and a second lower foam layer 42. The advantage realized by this arrangement lies in the offset positioning of the holes interspersed in both foam layers. Holes 34 punctuating the lower wall 30 of elastomeric envelope 38 remain positioned in line with the "sink" holes positioned in the second (bottom) layer of foam 42. Holes 32 punctuating the upper wall 28 of elastomeric envelope 38 are, as described above, offset from alignment with holes 34 in the lower surface of the envelope, but are aligned with the "sink" holes positioned in the first (top) layer of foam 40. Under this structure further dispersion of the flow of fluid occurs thus decreasing the localization of clogging debris and prolonging the effective life of the dressing. The remaining components, applications, and methods of use of the dressing are as described above in conjunction with Figure 1.

The present invention has been described in conjunction with certain preferred embodiments. Alternative embodiments and further applications of the invention will be anticipated by those skilled in the art without departure from the basic concepts and

principles of the invention. Certain materials have been described as suitable for the specific layers of foam and film although a variety of similar materials would be equally suitable. Certain geometries and dimensions have been described as appropriate under various conditions and with various applications of the dressing, especially in conjunction with open and re-enterable abdominal wounds. These geometries and dimensions are not intended as limiting but are described as representative of the various shapes and sizes possible using the fundamental layered structure of the dressing. The scope of the invention is therefore not limited by the foregoing description but is best defined by the specific claims that follow.

WHAT IS CLAIMED IS:

1. A removable wound closure comprising:
a porous pad which is permeable to fluids for placement on or in a wound, the
5 porous pad comprising:
a polymer foam layer having interconnecting cells; and
a first sheet of flexible film having a plurality of holes distributed over its surface, the
first sheet of flexible film being in contact with a surface of the foam layer so that in use, the
first sheet of flexible film is disposed between, and in contact with both of, the surface of
10 the wound and the foam layer, the first sheet of flexible film comprising an elastomeric film
or a flexible plastics film, whereby the first sheet of flexible film is resistant to the formation
of adhesions with the wound and is thereby easily removable from the wound;
a film drape which is impermeable to liquids for placement over the porous pad, the
film drape having an adhesive perimeter for sealing to an area of skin surrounding the
15 wound; and
connection means extending through the film drape and in flow communication with
the porous pad for connection to a source of negative pressure for stimulating a flow of
exuded fluids from the wound.
- 20 2. A closure according to claim 1 wherein the holes in the first sheet of flexible
film comprise slits or slots.
3. A closure according to claim 1 or 2 wherein the connection means comprises
a flange portion which is disposed between the film drape and the porous pad and a
25 tubular portion which extends through the drape for connection to the source of negative
pressure.
4. A closure according to claim 3 wherein the flange portion of the connection
means includes channels for directing flow of fluid from the porous pad to the tubular
30 portion.

5. A removable wound closure comprising:

a porous pad which is permeable to fluids for placement on or in a wound, the porous pad comprising:

5 a polymer foam layer having interconnecting cells; and

a first sheet of flexible film having a plurality of holes distributed over its surface, the first sheet of flexible film being in contact with a surface of the foam layer so that in use, the first sheet of flexible film is disposed between, and in contact with both of, the surface of the wound and the foam layer, the first sheet of flexible film comprising an elastomeric film
10 or a flexible plastics film;

a film drape which is impermeable to liquids for placement over the porous pad, the film drape having an adhesive perimeter for sealing to an area of skin surrounding the wound;

15 connection means extending through the film drape and in flow communication with the porous pad for connection to a source of negative pressure for stimulating a flow of exuded fluids from the wound; and

20 a second sheet of flexible film disposed between the film drape and the porous pad, said second sheet of flexible film being sealed to the first sheet of flexible film around their respective perimeters to form an envelope and the second sheet of flexible film being formed with holes so that when the connection means is connected to a source of negative pressure, wound exudate is drawn through the porous pad and out of the porous pad through the holes in the second sheet of flexible film.

25 6. A closure according to claim 5 wherein the holes in the first sheet of flexible film comprise slits or slots.

7. A closure according to claim 5 or 6 wherein the connection means comprises a flange portion which is disposed between the film drape and the porous pad and a

tubular portion which extends through the drape for connection to the source of negative pressure.

5 8. A closure according to claim 7 wherein the flange portion of the connection means includes channels for directing flow of fluid from the porous pad to the tubular portion.

10 9. A closure according to any one of claims 5 to 8 wherein the respective perimeters of the first and second sheets of flexible film are sealed together to form a flange of joined film extending outwardly beyond the perimeter of the porous pad.

 10. A closure according to any one of claims 5 to 9 wherein the holes in the first sheet of flexible film are offset with respect to the holes in the second sheet of flexible film.

15 11. A closure according to any one of claims 5 to 10 wherein the holes in the first sheet of flexible film are aligned with holes within a first contiguous portion of the polymer foam layer and the holes in the second flexible sheet are aligned with holes in a second contiguous portion of the polymer foam layer.

20 12. A closure according to claim 11 wherein the porous pad comprises at least one further polymer foam layer having interconnecting cells.

 13. A closure according to any one of claims 5 to 12 wherein an additional porous pad is disposed between the second sheet of flexible film and the film drape.

25

 14. A closure according to any one of claims 5 to 13 wherein the first sheet of flexible film is resistant to the formation of adhesions with the wound and is thereby easily removable from the wound.

15. A closure according to any one of claims 1 to 14 wherein the porous pad comprises a polymer foam layer having at least 90% of interconnecting cells.

16. A removable wound dressing, especially as would be applied to a large open wound that requires the drainage of fluid therefrom, said dressing comprising:

a first porous pad, permeable to fluids, for placement in contact with the wound, said first porous pad comprising:

a foam pad comprising a polymer based foam having interconnecting cells and having a plurality of dispersed transverse holes; and

an elastomeric envelope comprising first and second sheets of elastomeric film sealed at their periphery and enclosing said foam pad, each of said first and second sheets of elastomeric film having a plurality of dispersed holes therein;

a film drape, impermeable to fluids, for placement over said first porous pad, said film drape comprising an adhesive perimeter for adhering said film drape to an area of skin surrounding said wound when said first porous pad is placed in contact with said wound; and

a tube connector positioned through said film drape and in flow communication with said first porous pad, for connection to a source of negative pressure for initiating a flow of exuded fluids from said wound.

17. A removable wound dressing according to claim 16 further comprising:

a second porous pad, permeable to fluids, for placement over, and in contact with, said first porous pad, said second porous pad comprising a polymer foam having interconnecting cells

wherein said dispersed holes of said first sheet of elastomeric film are offset from alignment with said dispersed transverse holes in said foam pad, and said dispersed holes in said second sheet of elastomeric film are aligned with said dispersed transverse holes in said foam pad wherein said second sheet of elastomeric film is in contact with the wound when the removable wound dressing is in use.

18. A removable wound dressing, especially as would be applied to a large open wound that requires the drainage of fluid there from, the dressing comprising:

a first porous pad, permeable to fluids, for placement in contact with the wound, said first porous pad comprising:

5 a foam pad comprising a polymer based foam having interconnecting cells and having a plurality of dispersed transverse holes; and

an elastomeric envelope comprising first and second sheets of elastomeric film, sealed at their periphery, and enclosing said foam pad, said first sheet of elastomeric film having a plurality of dispersed holes therein, said dispersed holes being offset from
10 alignment with said dispersed holes in said foam pad, said second sheet of elastomeric film having a plurality of dispersed holes therein, said dispersed holes in said second sheet being aligned with said dispersed holes in said foam pad;

a second porous pad, permeable to fluids, for placement over, and in contact with, said first porous pad, said second porous pad comprising a polymer foam having
15 interconnecting cells;

a film drape, impermeable to fluids, for placement over said second porous pad and said first porous pad placed over said wound, said film drape comprising an adhesive perimeter for adhering said drape to an area of skin surrounding said wound;

and a tubular connector positioned through said film drape and in flow
20 communication with said second porous pad, for connection to a source of negative pressure for initiating a flow of exuded fluids from said wound.

Cassan Maclean
307 Gilmour Street
Ottawa, ON K2P 0P7
Canada

Agents for the Applicant

1/2

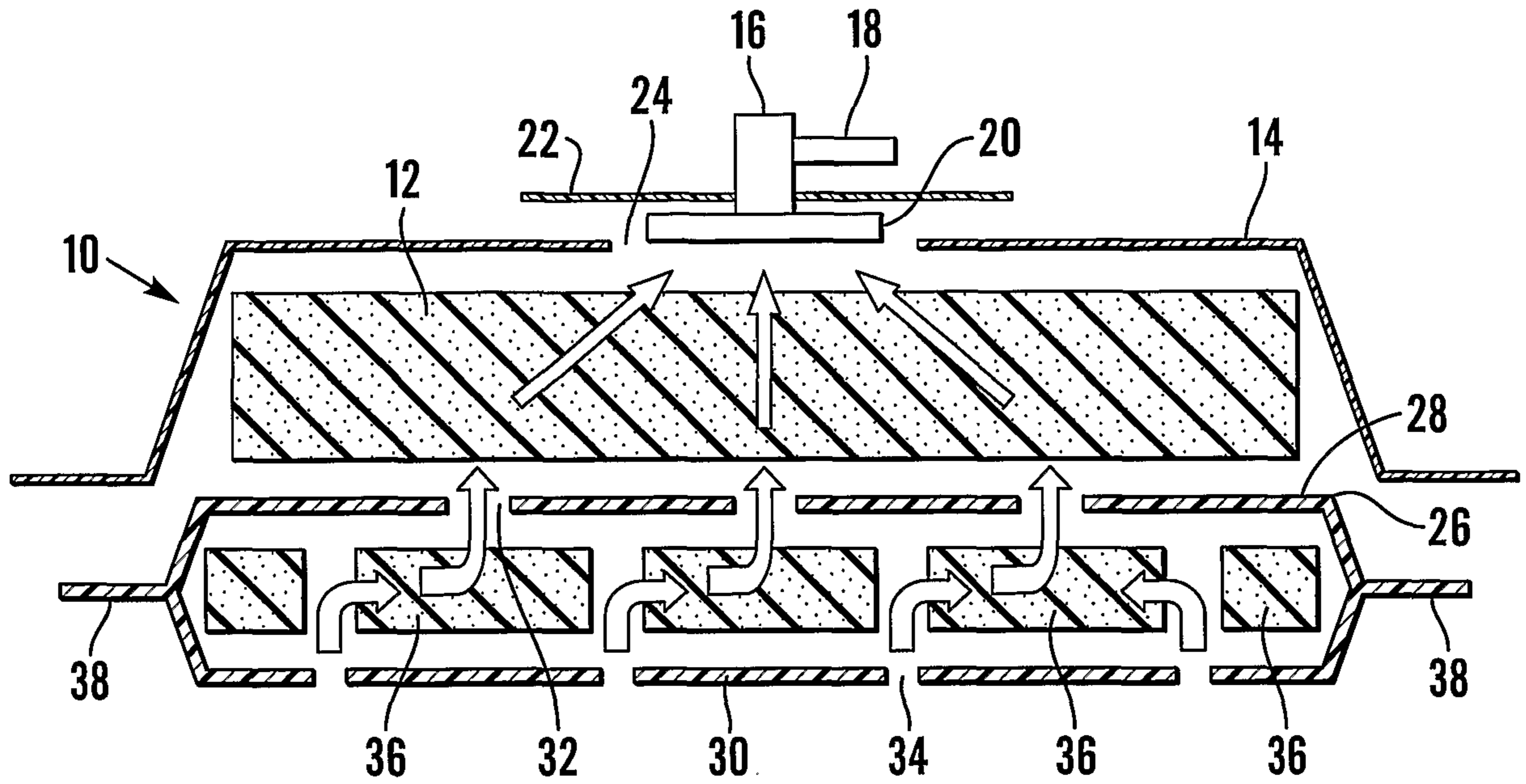

Fig. 1

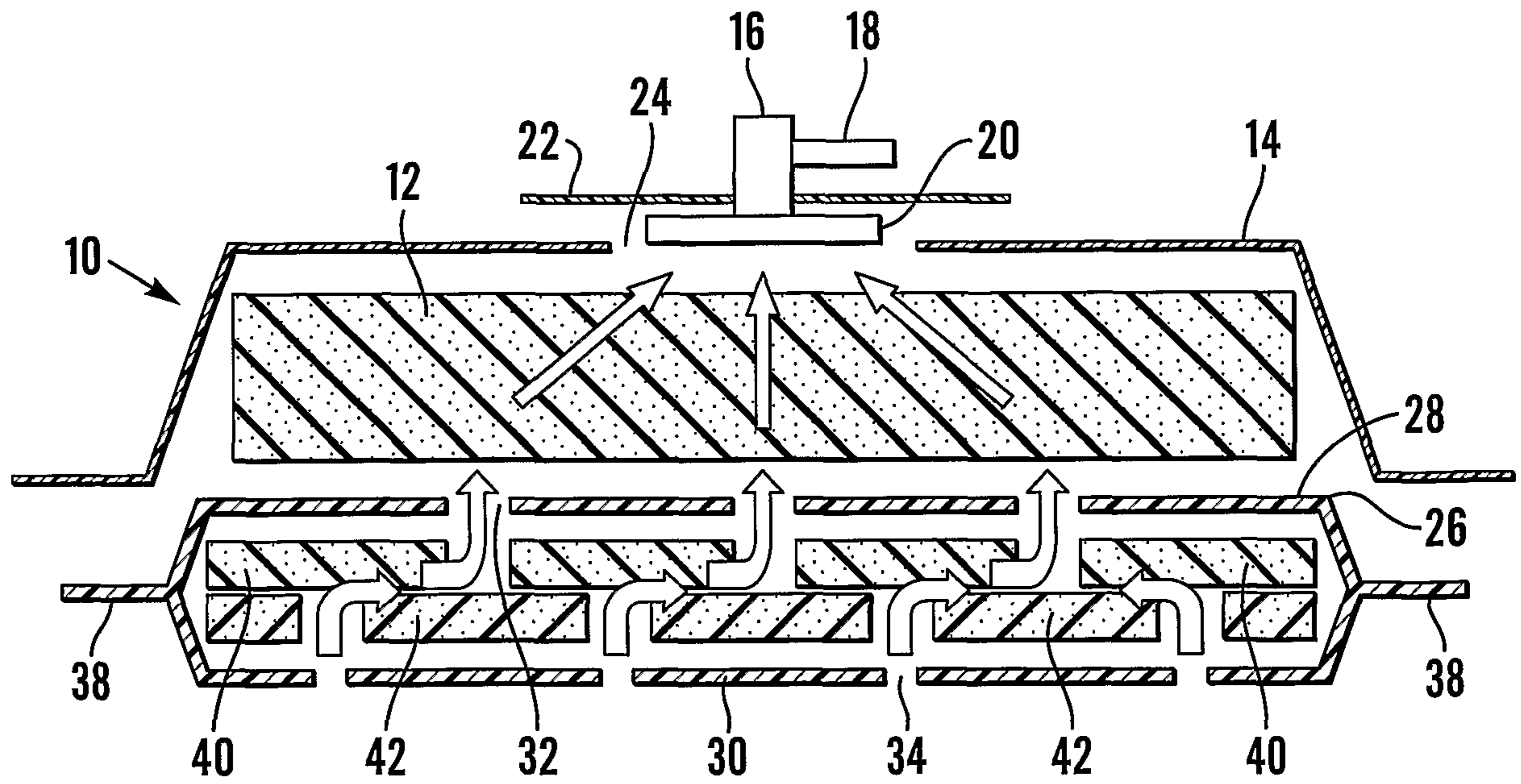

Fig. 2

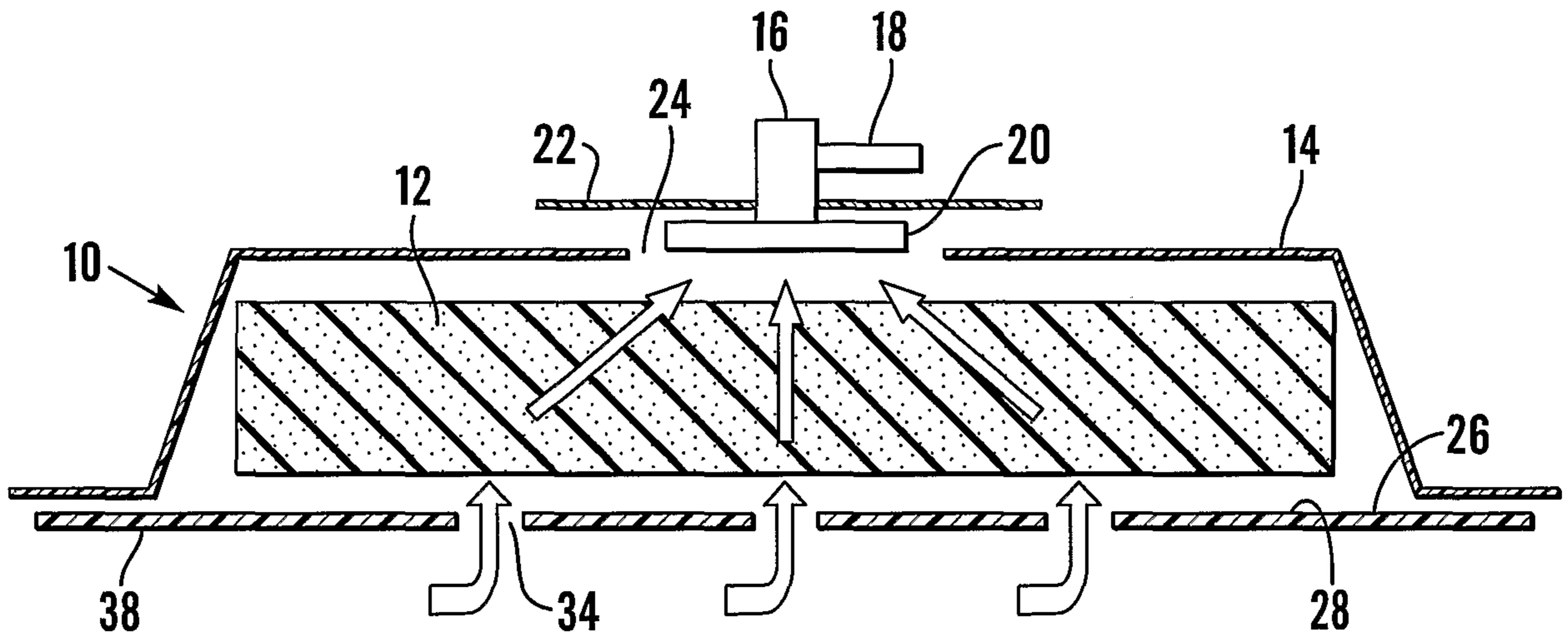

Fig.3

