

[54] **PORTABLE POWER WRENCH** 2,871,743 2/1959 Kelley..... 81/57.34
 [75] Inventor: **Suekichi Asada**, Nagoya, Japan 3,256,757 6/1966 Kochaver..... 81/57.34

[73] Assignee: **Kabushiki Kaisha Tokai Tekkosha**, Nagoya, Japan *Primary Examiner—James L. Jones, Jr.*

[22] Filed: **Jan. 9, 1974**

[57] **ABSTRACT**

[21] Appl. No.: **431,973**

[30] **Foreign Application Priority Data**
 July 30, 1973 Japan48-85729

[52] U.S. Cl. **81/57.34; 81/57.39; 81/65**

[51] Int. Cl. **B25b 13/50; B25b 13/52**

[58] Field of Search..... 81/57.34, 57.36, 57.39, 81/65

[56] **References Cited**
UNITED STATES PATENTS

568,697	9/1896	Pickett.....	81/65
2,546,224	3/1951	Johansen	81/57.34
2,737,839	3/1956	Paget.....	81/57.34

A portable power wrench consisting of a first and a second pipe holder, and a hydraulic cylinder for turning the two holder relative to each other. The first holder holds a first pipe and swingably holds the hydraulic cylinder. The second holder is swingably connected to a piston rod of the cylinder and holds a second pipe threadedly engaging the first pipe in such a manner that, upon forward actuation of the hydraulic cylinder, the second pipe is turned, but when the piston rod is moved reversely, the second holder slides on the second pipe without turning the latter.

4 Claims, 6 Drawing Figures

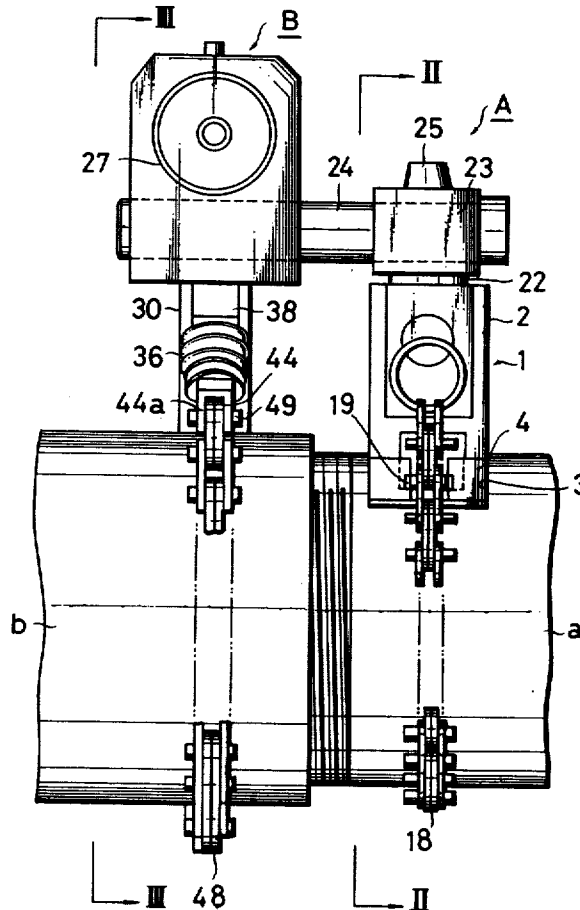

Fig. 2

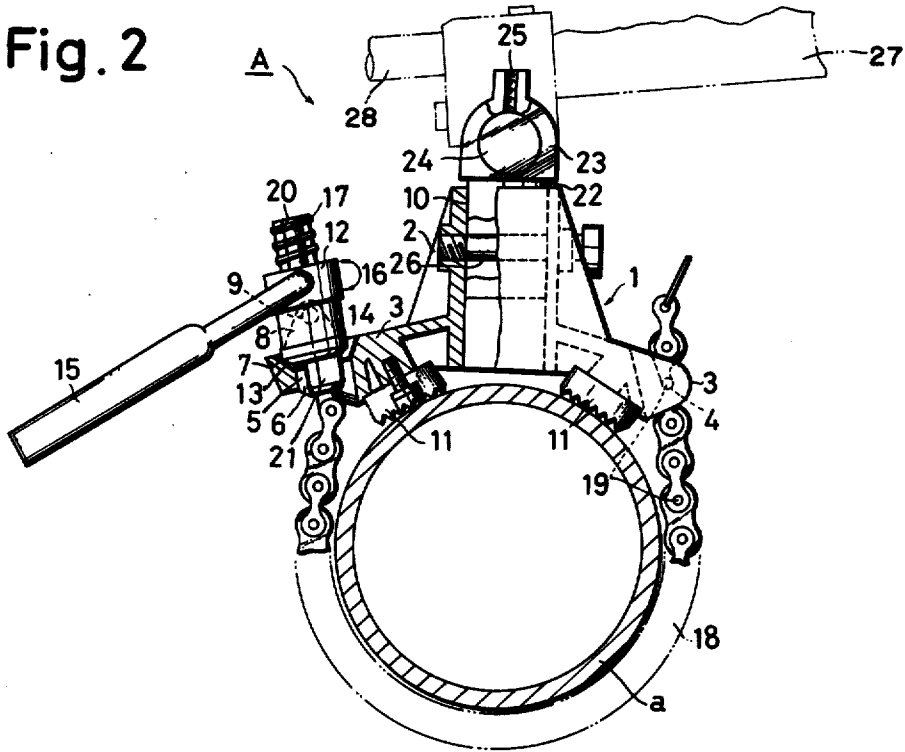

Fig. 1

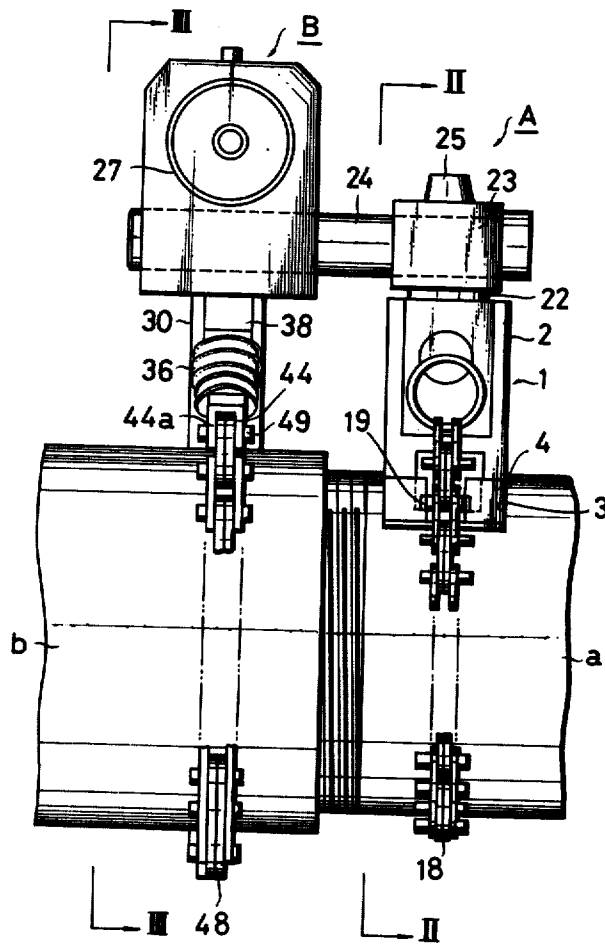

Fig. 3

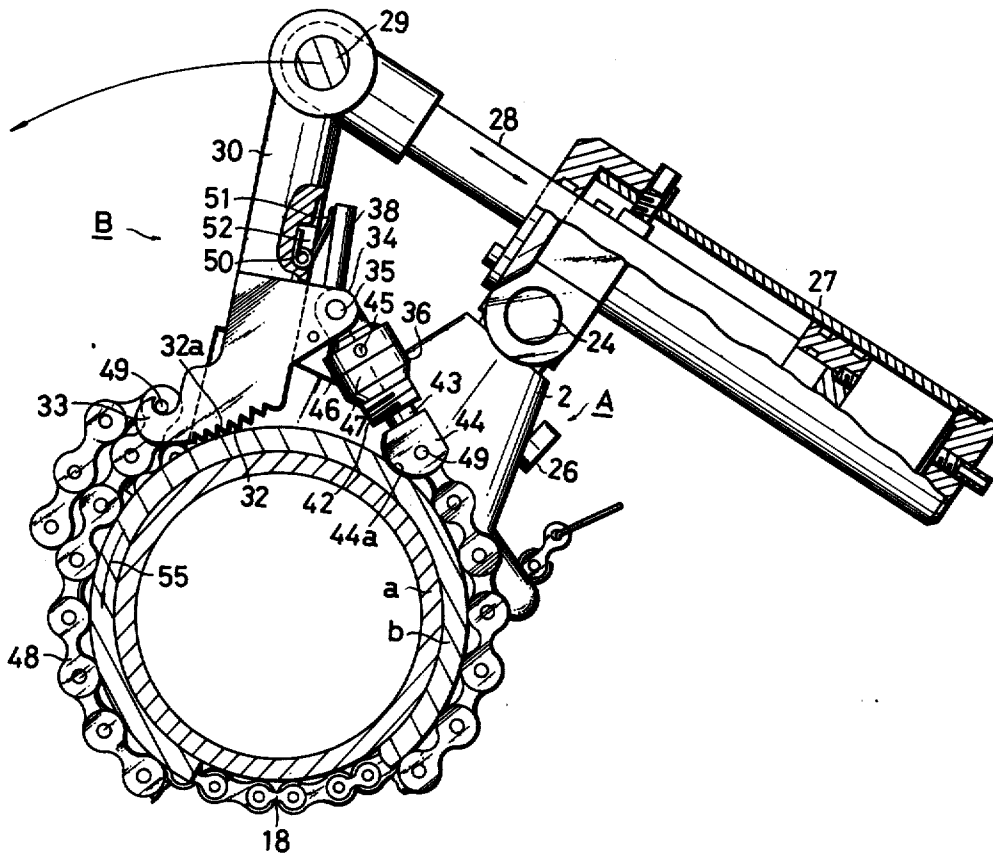

Fig. 4

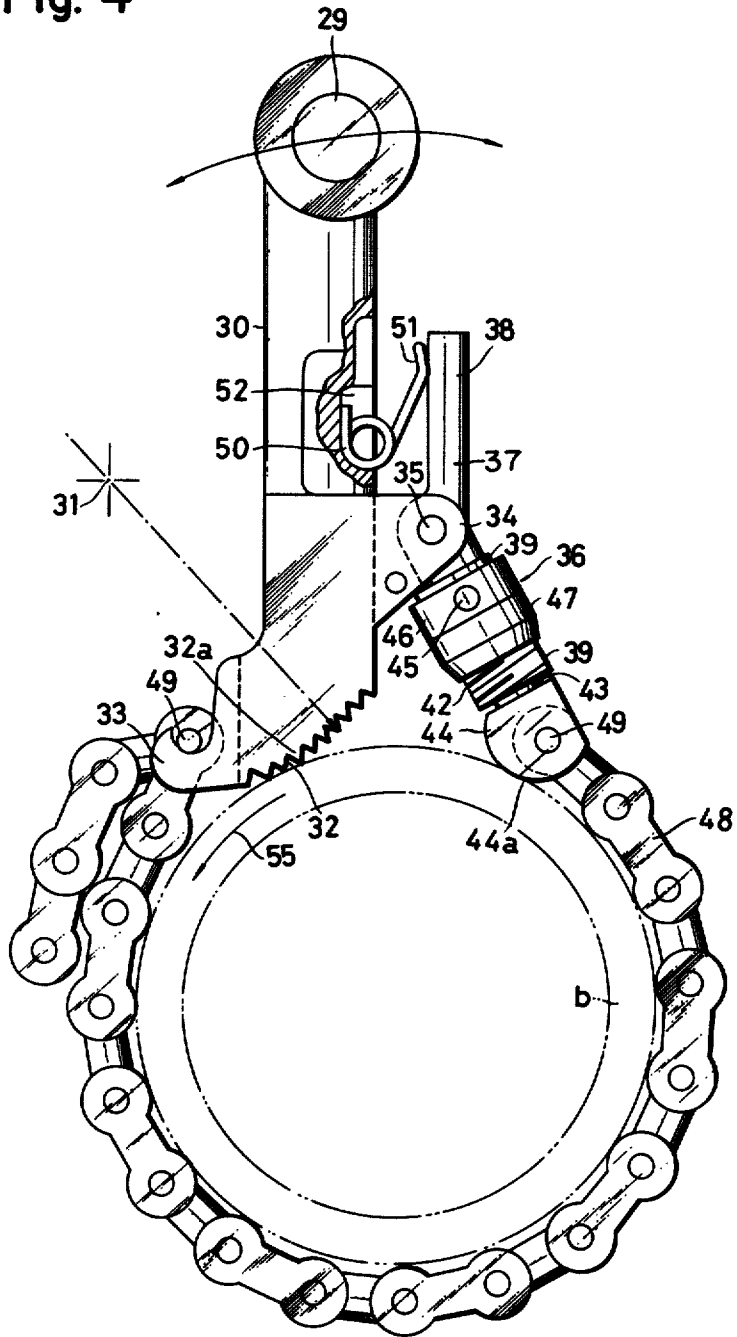

Fig. 6

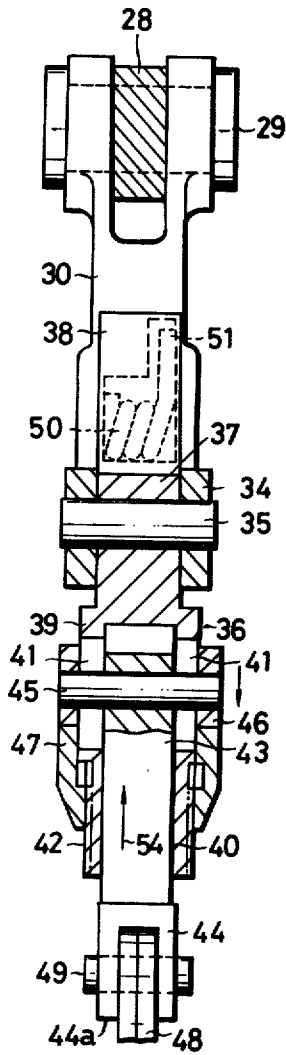
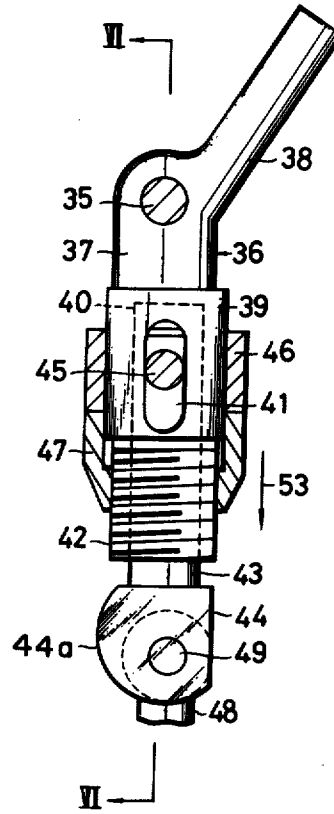

Fig. 5



PORTABLE POWER WRENCH

BACKGROUND OF THE INVENTION

1. Field of the Invention

This invention relates to a portable power wrench, and more particularly to a power wrench which hydraulically tightens the threaded joint of two pipes so as to improve the efficiency of the wrench for such tightening work.

2. Description of the Prior Art

Conventional pipe wrenches are manually operated. Thus, when pipe joints include comparatively large diameter pipes or are located in relatively inaccessible spaces, such as near the ceiling of a room, it is difficult and cumbersome to manipulate the conventional manual wrenches. Accordingly, the pipe connecting work by means of conventional wrenches is sometimes inefficient.

Therefore, an object of the present invention is to mitigate the aforesaid difficulty of the conventional wrench by providing a hydraulically operable power wrench of portable type.

SUMMARY OF THE INVENTION

According to the present invention, there is provided a portable power wrench which uses a hydraulic cylinder for threadedly connecting two pipes of comparatively large diameters with each other or a pipe with an elbow or the like. The wrench of the invention comprises a first and a second pipe holding means and a hydraulic cylinder means. The first holding means includes a bracket or body, a holding portion formed integrally with the body, so as to selectively hold a first pipe member to be joined, and a shaft secured to the body so as to extend parallel to the longitudinal axis of the first pipe member. The hydraulic cylinder is slidably carried by said shaft so as to be swingable about the shaft. The second holding means includes a swingable bar having one end pivotally connected to the free end of a piston rod of the hydraulic cylinder, and a pipe-holding portion provided at the opposite end of the swingable bar so as to selectively hold a second pipe member to be threadedly joined to the first pipe member. Said second holding means tightly holds the second pipe member when the piston rod of the hydraulic cylinder is extended from the cylinder, so as to turn the second pipe member in response to the actuation of the hydraulic cylinder, but the second holding means slides on the surface of the second pipe member when the piston rod reverses or is retracted into the hydraulic cylinder. Thus, upon repeated actuations of the hydraulic cylinder, the first and second pipe members are threadedly joined. To cope with the varied spacing between the first and second holding means, the hydraulic cylinder may slide on the shaft of the first holding means.

The first and second pipe members need not always be straight pipes. For instance, one of them can be an elbow connector.

With the power wrench of the aforesaid construction, the efficiency of the pipe connecting work can be greatly improved. Especially, when the work is to be carried out in a limited space, the operator can be relieved from complicated and cumbersome manipulation in such narrow workable space. Furthermore, the entire power wrench can be made in a portable fashion, so that it is very easy to handle.

BRIEF DESCRIPTION OF THE DRAWING

FIG. 1 is a side view of a power wrench, according to the present invention;

FIG. 2 is a view taken on II—II of FIG. 1, with a part thereof cutaway;

FIG. 3 is a partially cutaway view, taken on line III—III of FIG. 1;

FIG. 4 is an enlarged view of a swingable part of the power wrench;

FIG. 5 is a side view of a swingable rod of the power wrench; and

FIG. 6 is a sectional view taken along the line VI—VI of FIG. 5.

Like parts are designated by like numerals and symbols throughout the different figures of the drawings.

DESCRIPTION OF THE PREFERRED EMBODIMENT

Referring to FIG. 1, a portable power wrench according to the present invention comprises a first holding means A carrying a hydraulic cylinder and a second holding means B connected to a piston rod of the hydraulic cylinder. FIGS. 2 and 3 illustrate details of the two holding means.

The first holding means A includes a bracket or body 1 having a head portion 2. In the head portion 2 there is bored a cylindrical hold 10 so as to receive a stud 22 therein to be described hereinafter. A pair of vice-holders 3 are integrally formed with the body 1, and a vice-piece 11 is replaceably secured to each of the vice-holders 3. A hook 4 is formed at the right-hand side portion of the lower end of the body 1, as seen in FIG. 2, by bifurcating the edge thereof. A hole 5 is bored through the left-hand end portion of the body 1, as seen in FIG. 2, so as to receive therein a chain-holding bolt 20 to be described hereinafter. A pair of lugs 8 are integrally formed with the body 1, so as to face each other across the hole 5. The lower portion 6 of the hole 5, as seen in FIG. 2, has a rectangular cross section or at least one planar surface, and the upper portion 7 of the hole 5 is so tapered as to enlarge the hole diameter as the hole extends upwardly. A nut 12 threadedly carrying the bolt 20 is fitted in the tapered upper portion 7 of the hole 5. The nut 12 has an annular groove 14, so that the bolt 20 can be rotatably carried by a pair of pins 9 secured to the lugs 8. Lower end 13 of the nut 12 is so tapered as to fit in the tapered upper end portion of the hole 5.

The vice pieces 11 are mounted on the body 1 in such a manner that pipe-engaging surfaces of the vice pieces 11 substantially face toward the longitudinal axis of a first pipe member *a* to be joined, as shown in FIG. 2. The nut 12 is manually rotatable by a handle 15, as shown by arrow 16. The handle 15 can be detachably mounted on the nut 12.

A pipe-holding chain 18 has one end connected to the chain-holding bolt 20. After being extended around the pipe member *a*, a suitable portion of the chain 18 is fastened to the hook 4 of the body 1 by a chain pin 19. The chain-holding bolt 20 has one or more flattened surface portions 21, so that the bolt 20 would not rotate in the rectangular lower portion of the hole 5 of the body 1 by engagement of the flattened portions 21 of the bolt 20 with flat surfaces of that portion of the hole 5. A coil spring 17 is inserted between the top end of the bolt 20 and the nut 12, as shown in FIG. 2. After

the chain 18 is placed around the pipe member *a* by fastening a suitable chain pin 19 to the hook 4, the handle 15 is mounted on the nut 12, and the nut 12 is rotated by the handle 15 so as to tighten the chain 18. Thus, the chain 18 cooperates with the vice pieces 11 and securely holds the pipe member *a*.

The stud 22 fitted in the cylindrical hole 10 is fastened to the body 1 by a screw 26. The top portion 23 of the stud 22 holds a shaft 24 extending parallel to the longitudinal or axial direction of the pipe member *a* to be joined, which shaft 24 is secured to the stud by a screw 25. A hydraulic cylinder 27 is slidably mounted on the shaft 24, so that the cylinder 27 can swing about the shaft 24, as can be seen from FIG. 3. The hydraulic cylinder 27 carries a piston rod 28 which is hydraulically actuatable, so as to reciprocate in a plane perpendicular to the longitudinal axis of the shaft 24.

Referring to FIGS. 3 to 6, the second holding means B includes a swingable bar 30 having one end pivotally connected to the free end of the piston rod 28 by a connector pin 29. The opposite end of the swingable bar 30 has a serration 32 formed along an imaginary arcuate surface 32*a* whose center of curvature 31 is offset from the position of the connector pin 29, as shown in FIG. 4. The shape of the serration 32 is such that, when the swingable bar 30 is actuated by extension of the piston rod 28 of the hydraulic cylinder 27, the serration 32 operatingly engages the peripheral surface of the pipe member *b*, but when the piston rod 28 moves reversely into the hydraulic cylinder 27, the serration 32 does not provide any substantial friction with the peripheral surface of the pipe member *b*.

The lower end of the swingable bar 30 has a hook 33 which receives a chain pin 49 of a pipe-holding chain 48, as seen in FIG. 4. A pair of brackets 34 are integrally formed with the swingable bar 30 at an intermediate portion thereof, so as to receive a bent bar 37 which is pivotally connected to the brackets by a pin 35. The bent bar 37 serves to hold an end member 43 secured to one end of the pipe-holding chain 48, by forming a part of the chain connector unit 36. The bent bar 37 has a leg 38, which is engageable with a linear end portion 51 of a coil spring 50 located in a seating recess 52 of the swingable bar 30. A hollow cylindrical portion 39 is integrally formed with the lower portion of the bent bar 37, as seen in FIGS. 5 and 6. The cylindrical portion 39 has a vacant space 40 defined therein so as to receive the end member 43 of the chain 48. The cylindrical wall of the hollow space 40 has a pair of aligned slots 41, through which a pin 45 secured to the end member 43 penetrates. Opposite ends of the pin 45 are secured to a ring 46 which is slidably fitted on the outer peripheral surface of the cylindrical portion 39. The lower portion 42 of the outer surface of the cylindrical portion 39 is threaded, so as to threadedly receive a nut 47, as seen in FIGS. 5 and 6. The top edge of the nut 47 engages the ring 46, so that the position of the ring 46 and the end member 43, relative to the bent bar 37 can be adjusted by turning the nut 47 engaging the threaded portion 42 of the bent bar 37.

The lower end of the end member 43 is pivotally connected to the chain 48 by a chain pin 49 through a U-shaped connector 44, as shown in FIGS. 4 to 6. The U-shaped connector 44 has arcuate edge surfaces 44*a*.

In operation, the pipe member *a* and *b* are aligned by engaging a part of the threaded portions thereof, as shown in FIG. 1. The pipe-holding chain 18 of the first

holding means A is released from the hook 4, and the vice-pieces 11 are placed respectively in a proper position on the peripheral surface of the first pipe member *a*. The chain 18 is wound around the pipe member *a*, and it is looped by connecting a suitable part of the chain 18 to the hook 4 of the body 1 by a chain pin 9. The nut 12 is turned by the handle 15 so as to move the bolt 20 away from the pipe member *a* for tightening the looped chain 8 against the first pipe member *a*. Similarly, the chain 48 of the second holding means B is freed from the hook 23 of the swingable bar 30, and it is wound around the second pipe member *b* and looped by connecting a suitable portion of the chain back to the hook 33 by a chain pin 49. The nut 47 is turned in such a manner that the end member 43 of the chain 48 is moved away from the pipe member *b*. Thus, the chain 48 is tightened against the peripheral surface of the second pipe member *b*, while causing the serration 32 of the swingable bar 30 and the arcuate surface 44*a* of the connector 44 to engage the peripheral surface of the second pipe member *b*.

If the hydraulic cylinder 27 is actuated to extend the piston rod 28 from the cylinder, under such conditions, the swingable bar 30 is turned about the longitudinal central axis of the aligned pipe members *a* and *b*, while the hydraulic cylinder 27 itself is slightly swayed about the shaft 24. At this moment, if the first holding means A is held stationary, for instance by connecting the bracket or the body 1 to a stationary member (not shown), the turning of the swingable bar 30 results in a rotation of the second pipe member *b* in a direction, as shown by arrow 55 in FIGS. 3 and 4. The coil spring 50 provides a kind of buffering action in the pipe turning operation by the swingable bar 30, and the serration 32 assists in transmitting the turning movement of the bar 30 to the pipe member *b*. Thus, the second pipe member *b* is turned relative to the first pipe member *a*, for completing the threaded connection of the two pipe members.

After being fully extended the piston rod 28 may be retracted to the cylinder 27 by suitable hydraulic action, the operating engagement of the serration 32 with the peripheral surface of the second pipe member *b* being released. Thus, the reverse movement of the piston rod 28, i.e., the movement toward the hydraulic cylinder 27, will cause the bar 30 to swing back, but the chain 48 slides along the peripheral surface of the pipe member *b* without turning the pipe member *b*, because the friction between the two pipe members *a* and *b* at the threaded portions thereof is large enough to allow the sliding reverse movement of the serration 32 and the chain 48 on the peripheral surface of the second pipe member *b*.

Once the piston rod 28 is fully retracted into the hydraulic cylinder 27, the rod 28 will be again pushed outwardly relative to the cylinder 27. As a result, the bar 30 swings so to cause the serration 32 to operative engage the peripheral surface of the second pipe member *b* and to turn the pipe member *b* in the direction of the arrow 55, as described above. Thus, the threaded engagement between the pipe members *a* and *b* can be fully tightened by repeated actions of the hydraulic cylinder 27 causing reciprocation of the piston rod 28.

It may be noted here that the second pipe member *b* will axially move toward the first pipe member *a* in response to the aforesaid rotation of the former, due to

5

6

the threaded engagement therebetween. Such movement of the two pipe members in the axial direction thereof will be absorbed during the sliding reverse movement of the chain 48 of the second pipe-holding means B and by sliding of the hydraulic cylinder 27 on the shaft 24.

It is apparent to those skilled in the art that the power wrench of the present invention can be used to cause the second pipe member *b* to rotate in a direction opposite the arrow 55, e.g., for releasing the threaded connection of the second pipe member *b* to the first pipe member *a*. For instance, the first holding means A may be mounted and tightened on the second pipe member *b* and kept stationary by a suitable means (not shown), and the second holding means B may be operatively mounted on the first pipe member *a*. Then, the actuation of the power wrench will result in the disengagement of the threaded connection between the two pipe members *a* and *b*.

I claim:

1. A portable power wrench, comprising a first holding means including a body having a head portion and vice holders integrally formed with the head portion, vice pieces detachably secured to the vice holders to substantially immovably hold a first pipe member relative to the body, said head portion being provided with a hole, a stud secured in said hole, a shaft received by said stud, said first pipe member being held by said holding means in such a manner that the longitudinal axial center line of the first pipe member extends parallel to said shaft, a hydraulic cylinder slidably mounted on said shaft and swingable about said shaft, said hydraulic cylinder having a piston rod which is reciprocally movable in a plane perpendicular to said shaft; and a second holding means including a swingable bar pivotally connected to said piston rod at one end thereof, a serration formed at the opposite end of the swingable bar along an arc whose center of curvature is offset from said end of the swingable bar connected to the

5

10

15

20

25

30

35

40

45

50

55

60

65

piston rod, and means for holding a second pipe member while causing said serration to engage the peripheral surface of the second pipe member, said second pipe member being axially aligned with said first pipe member when the two pipe members are held by said first and second holding means, respectively.

2. A wrench according to claim 1, wherein said first holding means further includes a chain cooperating with said vice holders, and said body has a chain-end-receiving hole bored at one end of the vice holders and a hook formed at the opposite end of the vice holders, said chain having an end member with a least one planar surface which end member is fitted in said chain-end-receiving hole of the body, said chain-end-receiving hole having at least one planar surface engageable with said planar surface of the end member, said body having a chain end holding means holding said chain end member in said chain-end-receiving hole and a spring inserted between the chain end member and said chain end holding means, said chain including a plurality of chain pins each of which is adapted to be selectively engaged with said hook of the body.

3. A wrench according to claim 1 wherein said piston rod of the hydraulic cylinder is pivotally connected to said swingable bar by a connector pin.

4. A wrench according claim 1, wherein said means for holding said second pipe member in said second holding means includes a chain having an end member connected to one end thereof, said swingable bar of said second holding means having a chain holding unit pivotally connected to an intermediate portion thereof, said chain holding unit adjustably holding said chain end member, said swingable bar having a hook integrally formed therewith at a position opposite to said chain holding unit, said chain having a plurality of chain pins each of which is adapted to be selectively engaged with said hook of the swingable bar.

* * * * *