

(No Model.)

J. J. HENZIE.  
UNDERTAKER'S FOLDING TRUCK.

No. 577,364.

Patented Feb. 16, 1897.

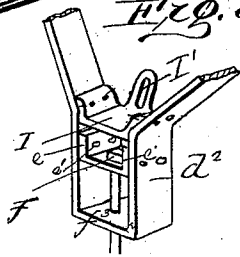
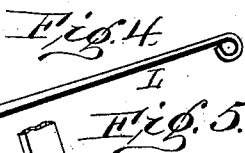
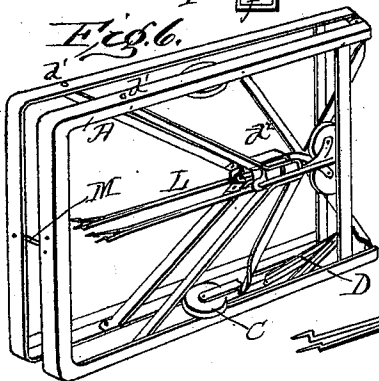
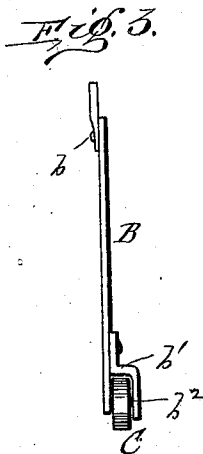
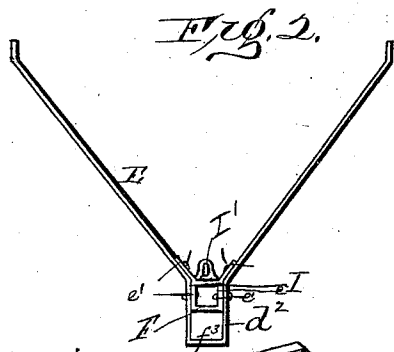
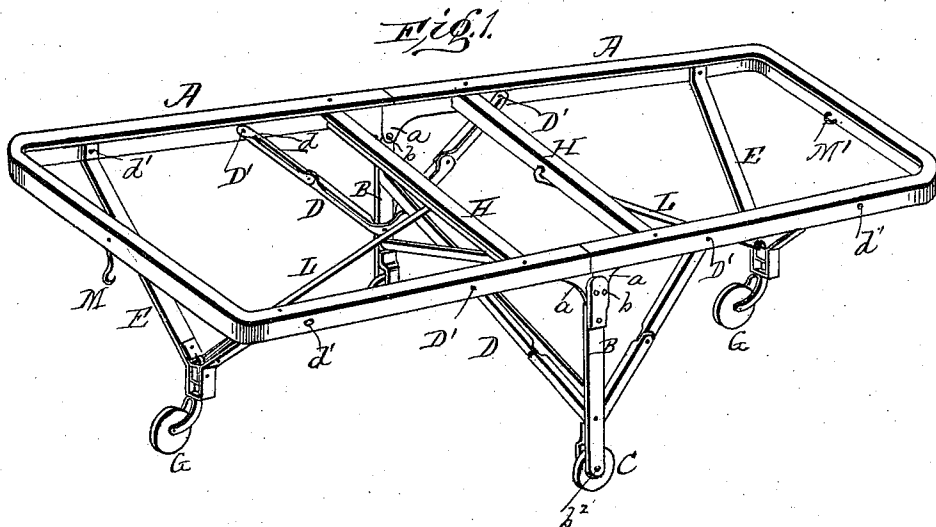

Witnesses:  
*J. M. Swales*  
*Alfred Mahan*

*Jacob J. Henzie*  
 Inventor  
 By *Henry P. Blair*  
 Attorney

# UNITED STATES PATENT OFFICE.

JACOB J. HENZIE, OF DEEP RIVER, IOWA.

## UNDERTAKER'S FOLDING TRUCK.

SPECIFICATION forming part of Letters Patent No. 577,364, dated February 16, 1897.

Application filed December 1, 1896. Serial No. 614,052. (No model.)

*To all whom it may concern:*

Be it known that I, JACOB J. HENZIE, a citizen of the United States, residing at Deep River, in the county of Poweshiek and State of Iowa, have invented certain new and useful Improvements in Undertakers' Folding Church-Trucks; and I do declare the following to be a full, clear, and exact description of the invention, such as will enable others skilled in the art to which it appertains to make and use the same, reference being had to the accompanying drawings, and to the letters of reference marked thereon, which form a part of this specification.

My invention relates to an improved undertaker's folding and noiseless truck, being particularly designed for moving caskets or coffins in churches, but being also adapted for use as a display-truck for pianos, organs, stoves, or like articles.

The invention consists in a novel construction and arrangement of parts whereby the truck may be folded into compact form when not in use and placed or carried in small compass and may be readily extended for use and firmly braced and locked when so extended and at the same time rendered noiseless when in use, and to certain novel features in the construction and arrangement of parts, all as hereinafter described.

In the accompanying drawings, Figure 1 is a perspective view of my improved truck, showing the same extended and ready for use. Fig. 2 is a front or end view of the end standard. Fig. 3 is a side elevation of one of the centerstandards. Fig. 4 is a perspective view of the split spring brace-arm. Fig. 5 is a perspective view of the lower end of the end standard. Fig. 6 is a perspective view of the truck folded.

The main or table portion A is preferably made of angle-steel of inverted-L form in two sections, the abutting ends being provided with depending lugs or ears *a*, riveted to the ends of the sections.

B B represent upright central standards made of either flat or angle iron or steel, with the upper ends made wide enough to receive the pivots *b b*, on which the ends of the frame-sections are mounted. The lower ends of these standards have riveted thereto angle-

bars *b'*, which form in connection with the ends of the standards the bearings or journals *b<sup>2</sup>* for the side wheels C C.

D D are jointed brace-arms connected at one end, as shown at *D'*, to the frame by pivotal connections and at the other ends to the side standards B B. These brace-arms at their point of connection with the frame are bent inward, as shown at *d d*, so that they will readily close within the frame when the truck is folded, as hereinafter described.

E E represent the end standards or supports, pivotally connected at each end to the frame at a point about midway between the pivot or connection of the brace-arms D D and the ends of the frame, as shown at *d' d'*, which standards are preferably made in substantially V form, with the lower end made in rectangular form, as shown at *d<sup>2</sup>*. A plate F, having arms *e e* for connecting it to the inclined side arm, as shown at *e'*, and which plate in connection with the lower wall *f<sup>3</sup>* of the rectangular portion of the standards form the support for the swivel-wheels G.

The wheels G are made in caster form, with a shoulder to abut against the lower face of the lower wall *f<sup>3</sup>*. The shank portion or swivel-post being screw-threaded passes through perforations in the wall *f<sup>3</sup>* and plate F and is connected thereto by means of a nut *f*, bringing the shoulder up to the bottom of the standard and by which means to render the same noiseless.

H H are cross brace-arms connected to the frame near the point of hinging and rigidly secured to the frame-bars, as shown at *h h*.

I I represent plates screwed to the sides of the end standards a short distance above the plates F, having a lug or ear projecting out therefrom at an angle of about sixty degrees and provided with an elongated slot I', hereinafter referred to.

Pivotally connected to the cross brace-arms are brace-rods L L, having the end split to form spring-arms and bent at said ends in angle form, forming a split spring-brace. These ends pass through the slot I'. The lower arm is made longer than the upper one, so that when the truck is extended for use the end of the lower arm will engage the lower end of the slot and the upper arm the

upper end of the slot and hold the end standards rigid, but permit the two arms to be pressed together or out of engagement with slot and allow the arm to pass through the slot when the truck is to be folded, as shown in Fig. 6.

M represents a hook, and M' a staple, one being secured to one end of the frame and the other to the opposite end for holding the frame when folded.

The wheels are preferably made of wood and covered with rubber tires.

By covering the wood wheels with rubber and having the side wheels run between the rigid standards and the end wheels pivoted or swiveled it will be seen that the truck is rendered noiseless and at the same time can be easily handled by one man.

From the above description it will be seen that as the frame and standards are made of metal and the frame made to fold and the supports adapted to fold within the frame, that while the truck will be exceedingly strong, at the same time it can be folded into very compact form for storage or transportation, and that the frame forms a crate for the same.

The truck when in use can be draped as shall be found desirable.

Having now described my invention, what I claim as new, and desire to secure by Letters Patent, is—

1. In a foldable truck, the end standards or supports in combination with the split spring brace-arms connected to the frame, and adapted to engage the end standards or supports, substantially as and for the purpose set forth.

2. In a foldable truck, the combination of the centrally-hinged main frame, the central side standards, the jointed brace-arms, connected to the frame and side standards, the end standards pivoted to the frame and carrying the swivel-wheels, the cross-bars, and the split spring brace-arms connected thereto to engage the end standards, substantially as and for the purpose set forth.

In testimony whereof I affix my signature in presence of two witnesses.

JACOB J. HENZIE.

Witnesses:

C. G. SARGENT,  
M. R. PHELPS.