

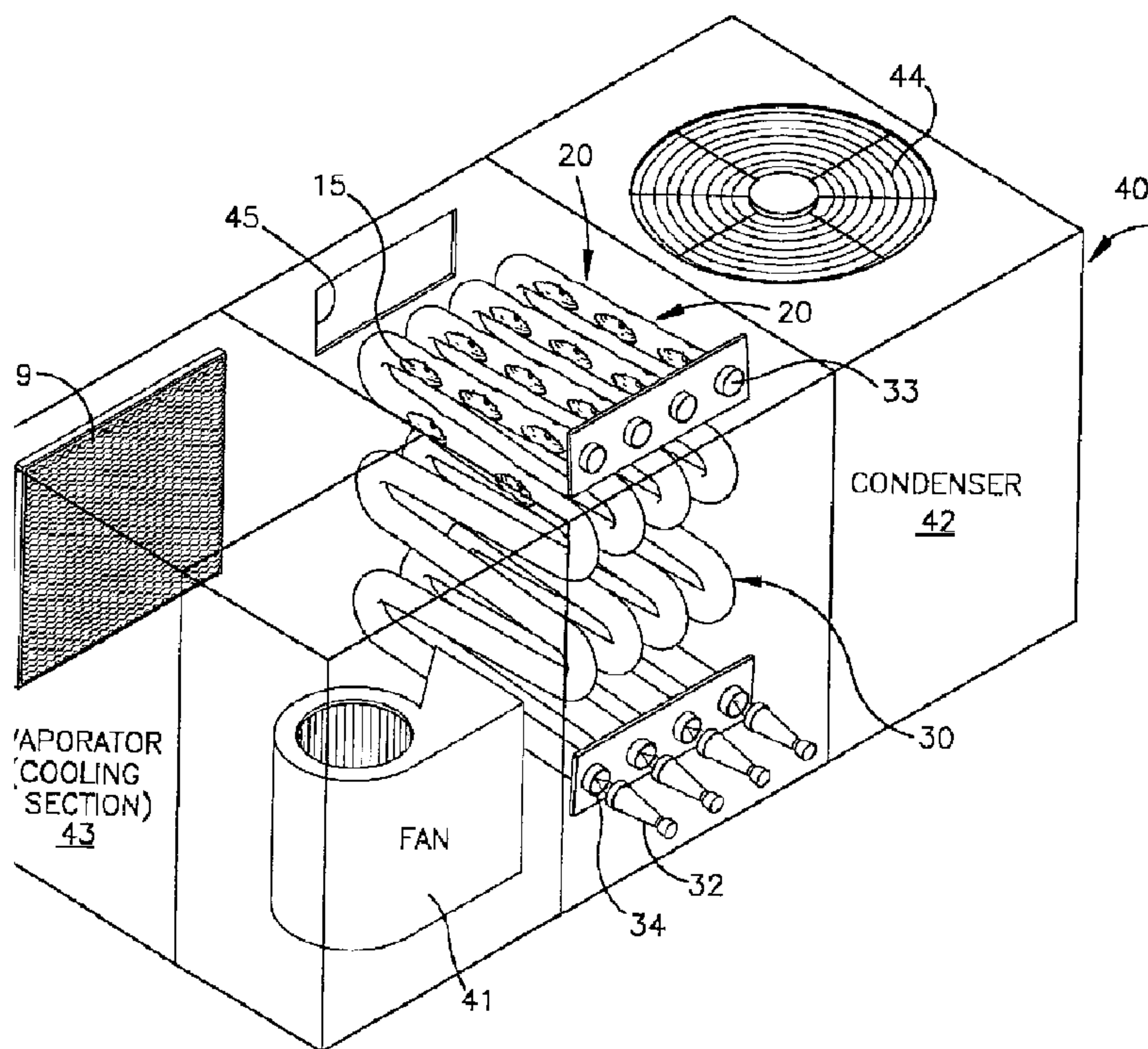

(22) Date de dépôt/Filing Date: 1999/11/12
 (41) Mise à la disp. pub./Open to Public Insp.: 2000/06/04
 (45) Date de délivrance/Issue Date: 2008/12/09
 (30) Priorité/Priority: 1998/12/04 (US09/205,955)

(51) Cl.Int./Int.Cl. *F28F 1/08* (2006.01),
F24H 1/24 (2006.01), *F24H 9/00* (2006.01),
F28F 1/40 (2006.01), *F28F 1/42* (2006.01),
F28F 13/12 (2006.01)
 (72) Inventeurs/Inventors:
 O'DONNELL, MICHAEL J., US;
 SLABY, TERRANCE C., US
 (73) Propriétaire/Owner:
 BECKETT GAS, INC., US
 (74) Agent: GOWLING LAFLEUR HENDERSON LLP

(54) Titre : TUBE D'ECHANGEUR DE CHALEUR COMPRENANT UNE STRUCTURE INTEGRALE DE LIMITATION ET DE TURBULENCE
 (54) Title: HEAT EXCHANGER TUBE WITH INTEGRAL RESTRICTING AND TURBULATING STRUCTURE



(57) Abrégé/Abstract:

A heat exchanger tube having an integral restricting and turbulating structure consisting of dimples formed by confronting indentations pressed into the sides of the heat exchanger tube. The dimples are comprised of indentations disposed in pairs which extend into the tube to such a depth as is necessary to significantly reduce the cross sectional area of the heat exchanger tube and provide a pair of converging, diverging flow nozzles to promote turbulence of the flue gases. In certain applications, the dimples are located along the sides of the heat exchanger tube, thereby providing unobstructed drainage for liquids even when the tube is bent into a serpentine shape.

Abstract

A heat exchanger tube having an integral restricting and turbulating structure consisting of dimples formed by confronting indentations pressed into the sides of the heat exchanger tube. The dimples are comprised of indentations disposed in pairs which extend into the tube to such a depth as is necessary to significantly reduce the cross sectional area of the heat exchanger tube and provide a pair of converging, diverging flow nozzles to promote turbulence of the flue gases. In certain applications, the dimples are located along the sides of the heat exchanger tube, thereby providing unobstructed drainage for liquids even when the tube is bent into a serpentine shape.

14-792

HEAT EXCHANGER TUBE WITH INTEGRAL RESTRICTING AND
TURBULATING STRUCTURE

Technical Field

5 The invention relates to appliances which employ tubular
elements for the purpose of conveying flue products and
transferring heat to fluid media adjacent to the exterior of the
tube. Product groups include, but are not limited to, furnaces,
water heaters, unit heaters and commercial ovens.

10

Background

15 A typical method of making heat exchangers for a variety of
gas and oil fired industrial or residential products is to bend a
metal tube into a serpentine shape thereby providing multiple
passes. Gases heated by a burner at one end of the heat
exchanger travel through the tube interior and exit the other end
of the heat exchanger. While the hot flue gases are within the
tube, heat is conducted through the metal walls of the tube and
transferred to the air or other fluid media surrounding the tube
20 thereby raising its temperature. In order to achieve efficient
heat transfer from the tubes, it is usually necessary to alter
the flow of gases by reducing their velocity and/or promoting
turbulence, mixing and improved contact with the tube surface. A
typical method for achieving this is by placing a separate
25 restrictive turbulating baffle inside the tube. These baffles
are typically metal or ceramic. One problem associated with
baffles in tubes is noise caused by expansion or contraction of
baffles or vibrations generated by the mechanical coupling to
components such as blowers or fans. Another difficulty related
30 to the use of baffles is that the heat exchanger tube cannot be

bent with a baffle already inserted so that baffles must be inserted after bending, limiting the typical location of baffles to straight sections of the heat exchanger tube which are accessible after bending. In addition, the use of separate
5 baffles increases the cost and difficulty of assembling the heat exchanger.

A known alternative to baffles is the technique of selectively deforming the tube to change its cross section. Such deformation causes a restriction to the gas flow due to the
10 change in cross section, achieving the effect of baffles. For example a known method is to flatten sections of the tube to achieve the desired restriction. A problem with the use of flattened sections is that this technique extends the cross section of the tube beyond that of the tube without deformations,
15 creating low spots in horizontal sections. Additionally, the flattened sections prevent the tube from passing through a hole of approximately the tube outside diameter as required for assembly in some applications.

While deformation of the heat exchanger tube can replace the
20 use of baffles in some applications, the deformation technique has had less than satisfactory results when applied in commercial and light commercial heating and air conditioning units. The design of most heating and air conditioning units is such that the heat exchanger is located downstream of the evaporator
25 section for cooling. Therefore, during use for air conditioning the cool air passing over the heat exchanger lowers the tube temperature below the dew point of air inside the tube, resulting in condensation inside the tube. Current configurations of tube deformation experience problems in draining this condensation
30 from the tube due to low spots in the horizontal sections of the tube. The low spots, which are caused by restricting deformations prevent the flow of liquid, allowing condensate to puddle and increase the likelihood of corroding the tube. For

this reason baffles are often used in heating and air conditioning unit heat exchangers to avoid premature failure due to corrosion.

5 Summary of the Invention

10 An object of the present invention is to provide a single piece heat exchanger tube which incorporates an integral restricting and turbulating structure and is suitable for use in residential heating, commercial heating/air conditioning and cooking units.

15 A more particular object of the present invention is to provide a heat exchanger tube with an integral restricting and turbulating structure which allows for drainage of liquid from the tube even when located in a horizontal section of the tube. Another more particular object of the invention is to provide a heat exchanger tube which can have integral restricting and turbulating structures between bends in a serpentine shaped heat exchanger.

20 The heat exchanger tube of the present invention generally comprises a metal tube having open ends. At one end is an inshot gas burner which heats gases flowing into the tube. Hot gases which have flowed through the length of the tube are exhausted out the other end of the tube. In many applications, the tube is bent into a serpentine shape to form several passes.

25 In order to maximize the efficient transfer of heat from the hot gases within the tube to the air or other fluid media outside the tube, a restricting and turbulating structure is used to slow the rate of travel of the hot gases through the tube. The restricting and turbulating structure of the present invention comprises dimples formed in the sides of the heat exchanger tube. The heat exchanger tube with dimples pressed in it maintains a cross sectional profile that does not extend beyond that of the undimpled tube, preventing difficulties associated with

30

flattening techniques. The dimples are comprised of pairs of indentations opposite one another along the tube. The indentations may extend into the tube to such depth as is necessary to provide the required restriction. These indentations are located directly opposite from each other, constituting a dimple which significantly reduces the cross sectional area of the tube. This dimple form provides a structure approximating a pair of converging, diverging nozzles. This two nozzle dimple structure provides improved turbulence. In applications requiring condensate drainage, the dimples are preferably located only along the sides of the tube, with the axis of the dimple being perpendicular to the vertical centerline of the tube as it is oriented in use. This provides a non-deformed tube along the bottom of the horizontal sections, which provides liquid condensate and an unobstructed flow path. In short, the dimples do not obstruct the flow of liquid out of the tube. Exact dimple geometry and location may be adjusted to maximize efficient turbulence of the hot gases, depending on the final shape and orientation of the tube.

The present invention provides a heat exchanger tube suitable for use in commercial and light commercial heating and air conditioning units as well as other commercial and residential products. The present invention incorporates an effective restricting and turbulating structure which does not require additional parts such as baffles. The present invention provides a heat exchanger tube having a cross section which does not extend outside the cross section of the heat exchanger tube without dimples. In addition, the present invention does not interfere with drainage of condensation, even when the heat exchanger tube is bent into a serpentine shape, thereby reducing the possibility of corrosion. In applications where condensate drainage is not an issue, dimples can be located rotationally at any desired angle from each other to provide additional mixing

and turbulence. The present invention also provides a superior turbulating method by providing adjacent converging, diverging nozzles in a tubular heat exchanger regardless of shape or tube orientation.

5 Other objects and advantages and a fuller understanding of the invention will be had from the following detailed description of the preferred embodiments and the accompanying drawings.

Brief Description of Drawings

10 Figure 1 is a side plan view of a portion of a heat exchanger tube made in accordance with the present invention;

Figure 2 is a top plan view of the heat exchanger tube as seen from the plane indicated by the line 2-2 in Figure 1;

Figure 3 is a section view taken along line 3-3 of Figure 2;

15 Figure 4 is a section view taken along line 4-4 of Figure 3;

Figure 5 is a perspective view of a heating and air conditioning unit having heat exchanger tubes made in accordance with the present invention;

20 Figure 6 is a side plan view of the heat exchanger tubes of Figure 5;

Figure 7 is cut away view of a residential/light commercial water heater having a flue tube made in accordance with the present invention, instead of a baffle as used in current practice;

25 Figure 8 is a front plan view of a plurality of heat exchanger tubes made in accordance with the present invention; and,

Figure 9 is a side plan view of the heat exchanger tubes of Figure 8.

30

Description of Preferred Embodiment

Figures 1-9 illustrate the construction of heat exchanger tubes 10, 30, 10' constructed in accordance with preferred

embodiments of the invention. The heat exchanger tube of the present invention may be used in many heating applications including, but not limited to, furnaces, water heaters, unit heaters and commercial ovens.

5 To facilitate the explanation, the tube construction shown in Figures 1-4 will be described first in connection with its use as a flue tube in a water heater (shown in Figure 7). Referring also to Figure 7, a gas heated residential water heater 21 is shown having a flue tube 10 of the present invention extending
10 upwardly through a water heating chamber 22. The flue tube 10 consists primarily of a metal tube 12. The metal tube 12 has an interior surface 16, an inlet end 17, and an outlet end 19. At least one parabolic shaped indentation 15 is pressed into the metal tube 12. In the preferred embodiment, the indentations 15
15 are pressed into the metal tube 12 in pairs located across the tube 12 from one another to the depth necessary to provide the desired restriction, up to the point of contacting the opposite indentation, see Figure 2. Confronting/opposing indentations 15, together define a dimple 20. The number of dimples 20 used as
20 well as the exact shape of the dimples may be adjusted to vary the restricting and turbulating characteristics of the flue tube 10. As seen in Figure 7, a gas burner 18 is disposed at the tube inlet end 17 which heats gases that move through the tube 10 and are exhausted through the outlet end 19 and into the water heater
25 vent system 25. The heat from these gases is conducted through the walls of the metal tube 10 to heat the water in the water heating chamber 22. The illustrated dimple structure when used in a water heater application, is more resistant to deformation and/or collapse of the tube 10 due to hydrostatic forces exerted
30 by the water in the heating chamber 22, as compared to prior art tube forming or flattening methods.

Figures 1-4 show the heat exchanger tube 10 in detail. Figure 1 shows the indentations 15 which preferably have a

parabolic shape and are disposed in opposing or confronting pairs to constitute the dimple 20, positioned along the length of the metal tube 12 so as to significantly reduce the cross sectional area of the tube. Each indentation 15 may contact the indentation 15 opposite it to form an interior cross section shown in Figure 3. In some applications (and as will be described in connection with Figures 5 and 6), the dimples 20 are located only along the sides of the metal tube 12 so that the bottom interior surface 13 is free from obstruction by dimples to allow drainage of fluid from the heat exchanger tube 10 even when the heat exchanger tube is bent into a serpentine shape as shown in Figure 5. The heat exchanger tube 10 maintains a circular cross sectional profile after dimples 20 have been installed as can be seen in Figure 3. Figure 1 shows a side plan view of the heat exchanger tube 10 with a dimple 20. At the center of each indentation 15 is an area 11 which is the area over which the indentation 15 may contact the indentation opposite it. Figure 3 shows an interior view of the dimple 20 having nozzle-like structures.

Figure 5 shows a plurality of serpentine shaped heat exchanger tubes 30 used in a heating and air conditioning unit 40. The heat exchanger tube 30 has six passes. Although dimples 20 are shown only in two passes of the metal tube 12, they may be located anywhere along the length of the metal tube at the designer's discretion. An inshot burner 32 is disposed at each heat exchanger tube inlet end 34.

When the heating and air conditioning unit 40 is used as a furnace, the burners 32 heat gases which pass through the six passes of the serpentine shaped heat exchanger tube 30. A fan 41 blows air across the heat exchanger tube 30 to be heated. Hot air then moves from the heating and air conditioning unit 40 via a duct 45. When the heating and air conditioning unit 40 is used as an air conditioner, the burners 32 are not lit. Refrigerant

is vaporized in the evaporator 43, causing the coils 49 of the evaporator 43 to become cold. The fan 41 draws air across the evaporator coils 49 where it is cooled and moves across the heat exchanger tube 30 prior to moving out of the heating and air conditioning unit 40. The refrigerant is then moved to the condenser 42 where it returns to liquid form. When the cold air moves across heat exchanger tube 30, the temperature of the air within the heat exchanger tube 30 cools to below the dew point, forming condensation within the heat exchanger tube 30. In most cases, the horizontal passes of the tube are parallel. Condensation does drain and does not pool in any portion of the tube. In the example shown, condensation drains more positively out of the heat exchanger tube 30 due to the constant downward slope of the horizontal portions of the tube. Since the dimples 20 are located only along the sides of the heat exchanger tube 30, the flow of condensation is unobstructed and hence no pooling of condensation occurs within the heat exchanger tube 30.

Referring to Figures 8 and 9, a heat exchanger tube set 50 for use in a vertical gravity type gas wall furnace is shown having a plurality of heat exchanger tubes 10' of the present invention. The inlet ends 17' are connected to a header plate 51 with gas burners 52 connected on the other side of the header plate to provide heat to the gases within the heat exchanger tube 10'. The outlet ends of the heat exchanger tubes are connected to an outlet bracket 53 where the heated gases are exhausted. See the explanation for Figures 1-4 above for the specific operation of the heat exchanger tubes 10' in this embodiment. As with the other disclosed embodiments, the dimples 20 may be disposed at any location along the length of the metal tube 12' as per design requirements.

The preferred embodiments of the invention have been illustrated and described in detail. However, the present invention is not to be considered limited to the precise

5 construction disclosed. Various adaptations, modifications and
uses of the invention may occur to those skilled in the art to
which the invention relates and the intention is to cover hereby
all such adaptations, modifications, and uses which fall within
the spirit or scope of the appended claims.

What is claimed is:

1. A heat exchanger apparatus, comprising:
 - at least one single piece tubular member having a generally circular cross section, said tubular member further comprising,
 - a restricting and turbulating structure, said structure comprising
 - at least one opposing pair of obstructions having a generally parabolic dimple shape disposed within said tubular member,
 - wherein each pair of obstructions being aligned with respect to each other and projecting into said tubular member until they confront one another to significantly reduce the cross sectional area of the tubular member and maintain the normal radius tube shape within the circular cross section along the entire tubular member,
 - said opposing obstructions forming pairs of adjacent converging, diverging nozzles, each nozzle having an aperture through which a fluid flows.

2. The heat exchanger apparatus of claim 1, wherein said opposing obstructions project into said tubular member until they contact one another.

3. A heat exchanger apparatus, comprising:
 - an inshot burner,
 - at least one single piece tubular member having a generally circular cross section, said tubular member further comprising,
 - a restricting and turbulating structure integral to said tubular member and disposed within said tubular member, said restricting and turbulating structure comprising at least one pair of opposing indentations having a generally parabolic dimple shape extending into said tubular member until said indentations confront one another to significantly reduce the cross sectional area of the tubular member,
 - each pair of said opposing indentations being aligned with respect to each other and disposed within said tubular member to form adjacent converging, diverging nozzles.

4. The heat exchanger apparatus of claim 3, wherein said indentations project into said tubular member until they contact one another.
5. The heat exchanger apparatus of claim 3, wherein said tubular member is bent into a serpentine shape.
6. The heat exchanger apparatus of claim 3, wherein a maximum depth of each indentation is one half the diameter of the tube, and a length of said indentation is at least equal to the diameter of the tube.
7. The heat exchanger apparatus of claim 3, comprising a plurality of tubular members.
8. A heat exchanger apparatus, comprising:
 - an inshot burner,
 - at least one single piece tubular member having a generally circular cross section, said tubular member further comprising,
 - a restricting and turbulating structure integral to said tubular member and disposed within said tubular member, said restricting and turbulating structure comprising,
 - several pairs of opposing indentations having a generally parabolic dimple shape extending into said tubular member until said indentations contact one another,
 - each pair of said opposing indentations being aligned with respect to each other and disposed within said tubular member along a central vertical axis of said tubular member on a side wall of said tubular member to form adjacent converging, diverging sections and allow unobstructed fluid drainage along a bottom wall of said tubular member.
9. The heat exchanger apparatus of claim 7, wherein said tubular member is bent into a serpentine shape.

10. The heat exchanger apparatus of claim 7, comprising a plurality of tubular members.

11. A water heater flue tube for a water heater, comprising:
 - a water heating compartment,
 - said flue tube comprising at least one single piece tubular member, said tubular member further comprising
 - a restricting and turbulating structure, said structure comprising at least one fluid path obstruction comprising,
 - at least one pair of confronting indentations, each indentation defining a generally parabolic shaped dimple, said dimples contacting one another and forming pairs of adjacent converging, diverging nozzles,
 - wherein each nozzle having an aperture for flowing flue gas and providing a restricting and turbulence inducing function as flue gas travels through said tubular member and resistance to collapse or deformation of said tubular member due to hydrostatic forces generated by water in said water heating compartment.

12. A heat exchanger apparatus, comprising:
 - at least one single piece tubular member having a normal radius and a generally circular cross section, said tubular member further comprising,
 - a restricting and turbulating structure, said structure comprising,
 - at least one opposing pair of obstructions having a generally parabolic dimple shape disposed within said tubular member and wherein each pair of obstructions being aligned with respect to each other and project into said tubular member until they contact one another and maintain the normal radius of the tubular member within the circular cross section along the entire tubular member,
 - said opposing indentations forming pairs of adjacent converging, diverging nozzles, each nozzle having an aperture through which a fluid flows.

13. A heat exchanger apparatus, comprising:
 - an inshot burner,

at least one single piece tubular member having a normal radius and a generally circular cross section, said tubular member further comprising,

a restricting and turbulating structure integral to said tubular member and disposed within said tubular member, said restricting and turbulating structure comprising,

at least one pair of opposing indentations having a generally parabolic dimple shape extending into said tubular member until said indentations contact one another and maintain the normal radius of the tubular member within the circular cross section along the entire tubular member,

each pair of said opposing indentations being aligned with respect to each other and disposed within said tubular member to form pairs of adjacent converging, diverging nozzles, each nozzle having an aperture through which fluid flows.

14. The heat exchanger apparatus of claim 13, wherein said tubular member is bent into a serpentine shape.

15. The heat exchange apparatus of claim 13, comprising a plurality of tubular members.

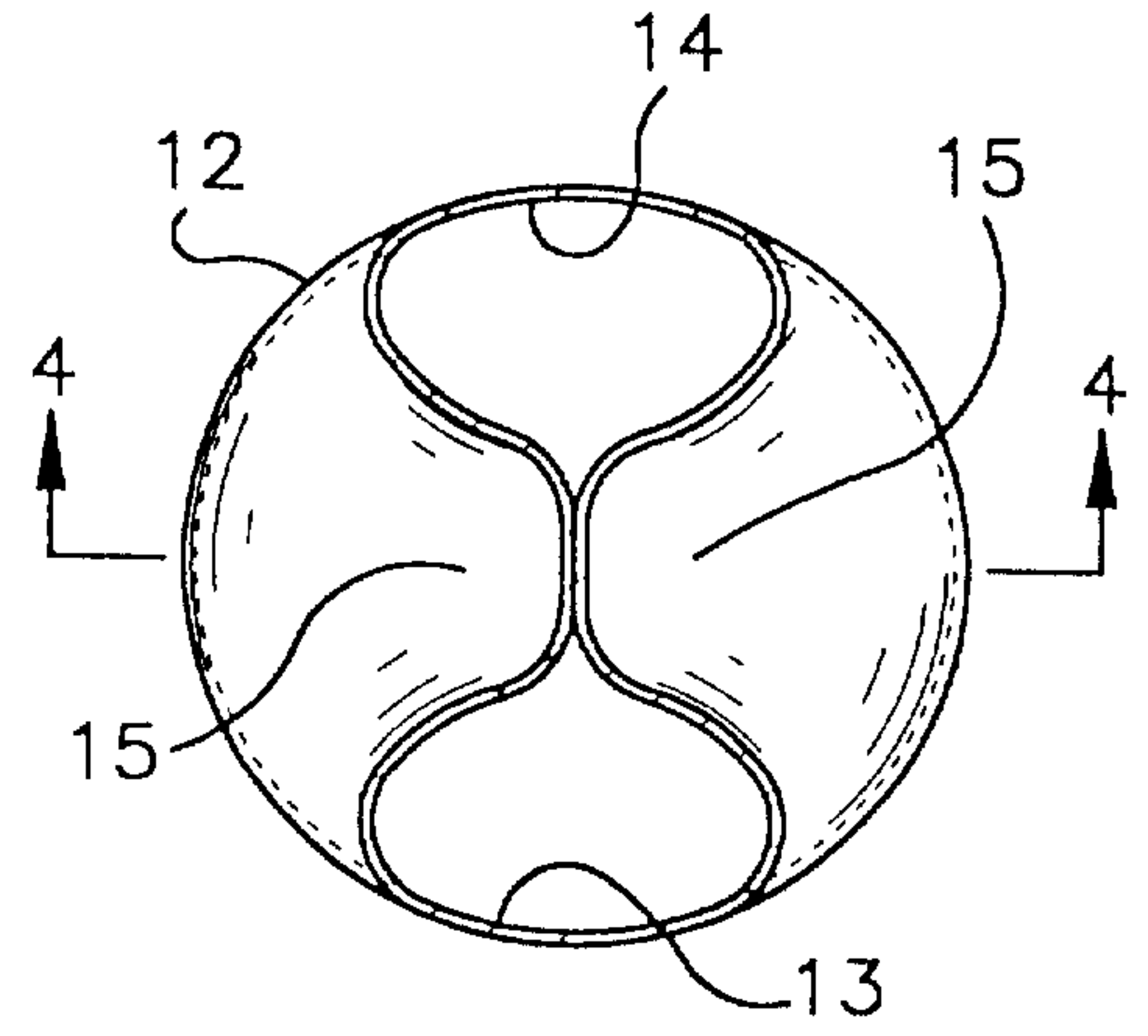
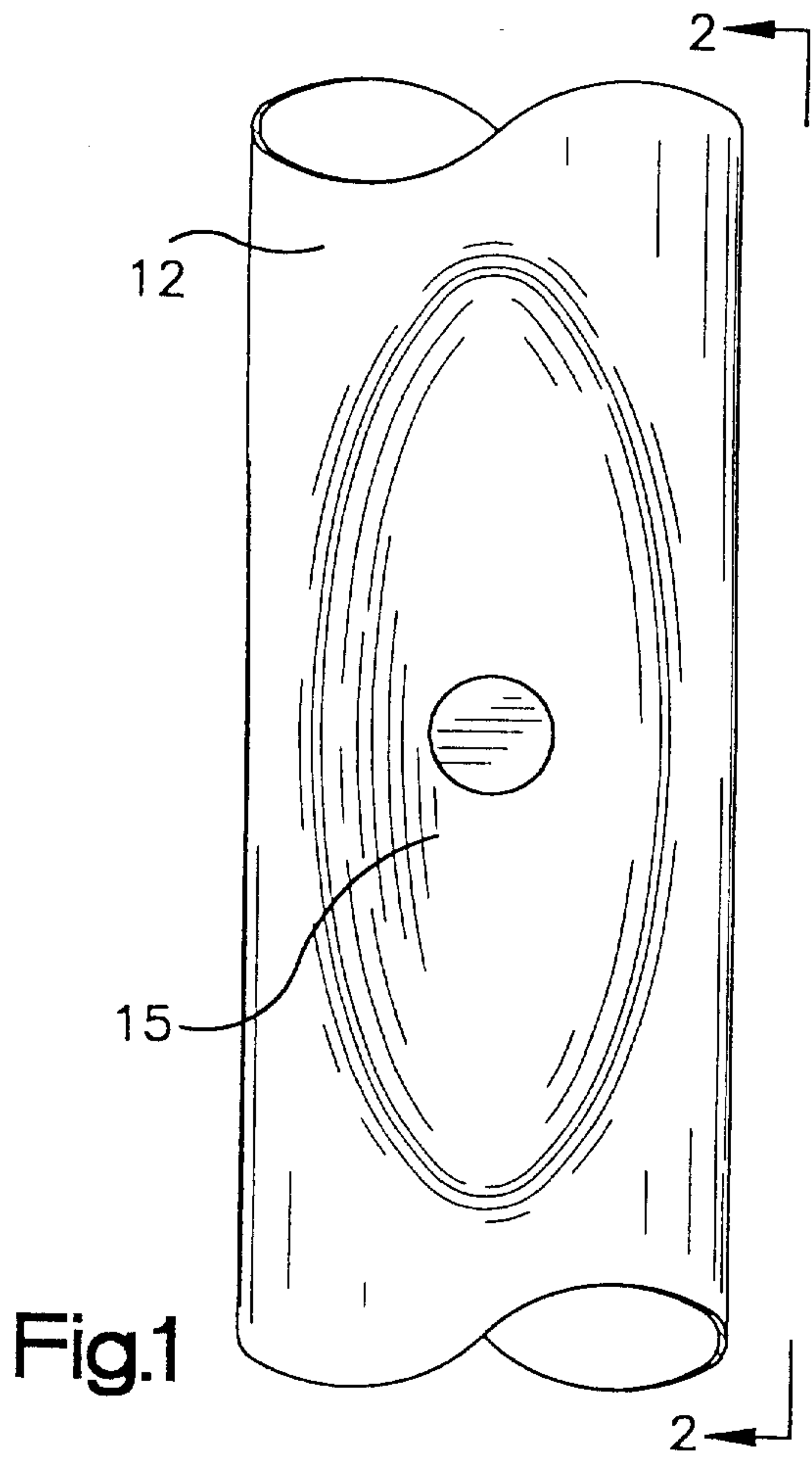

Fig. 3

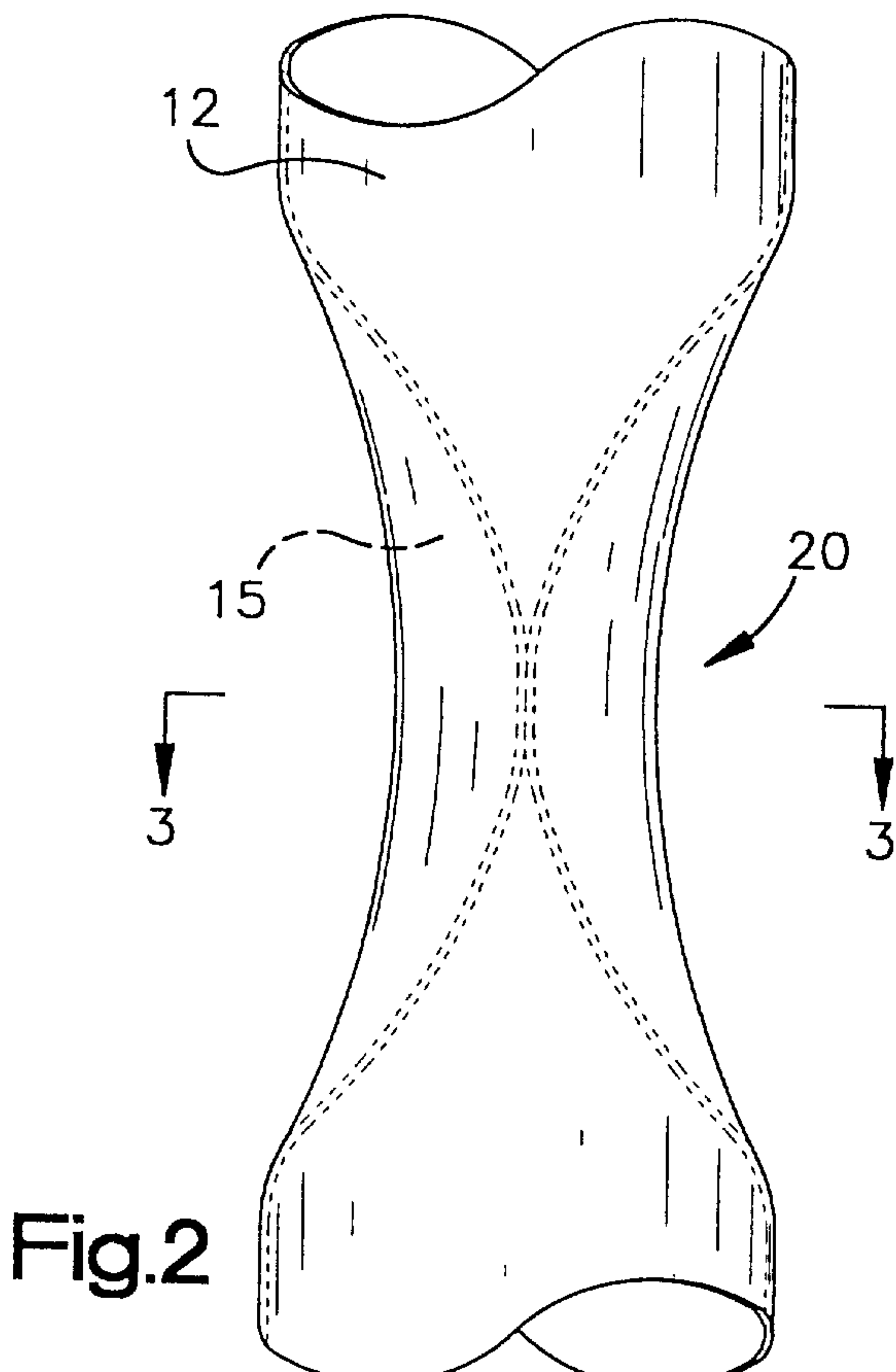
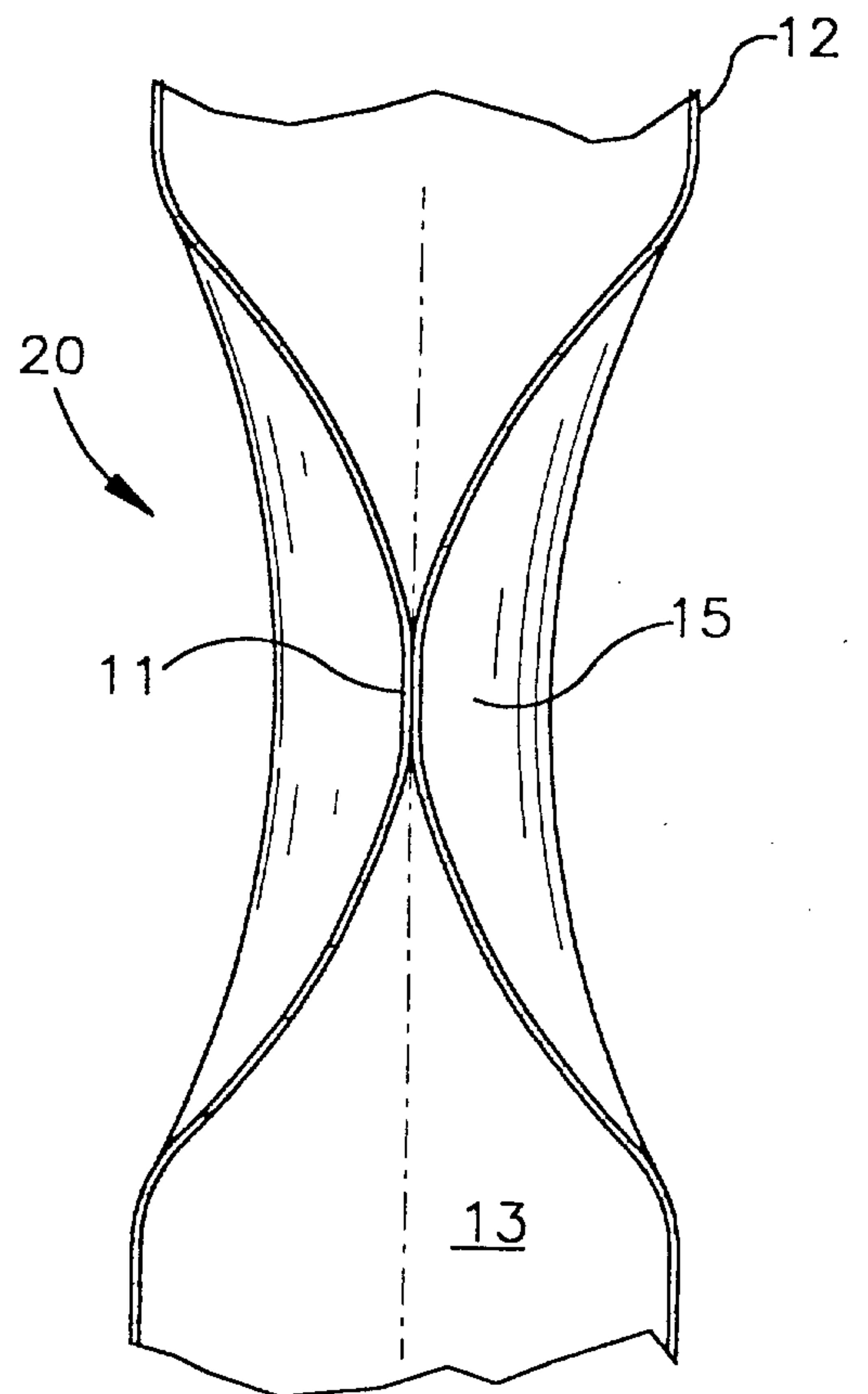

Fig. 2



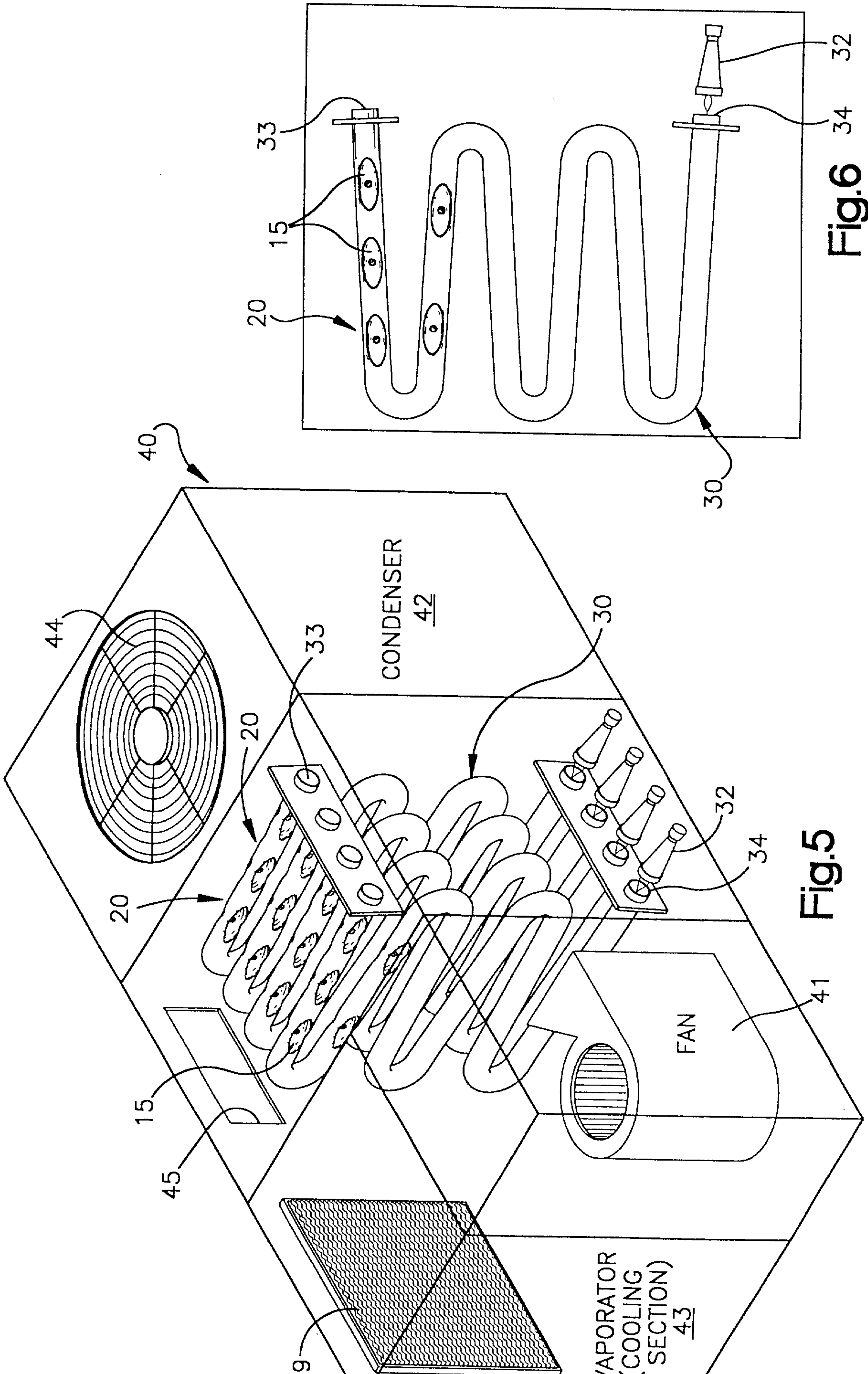
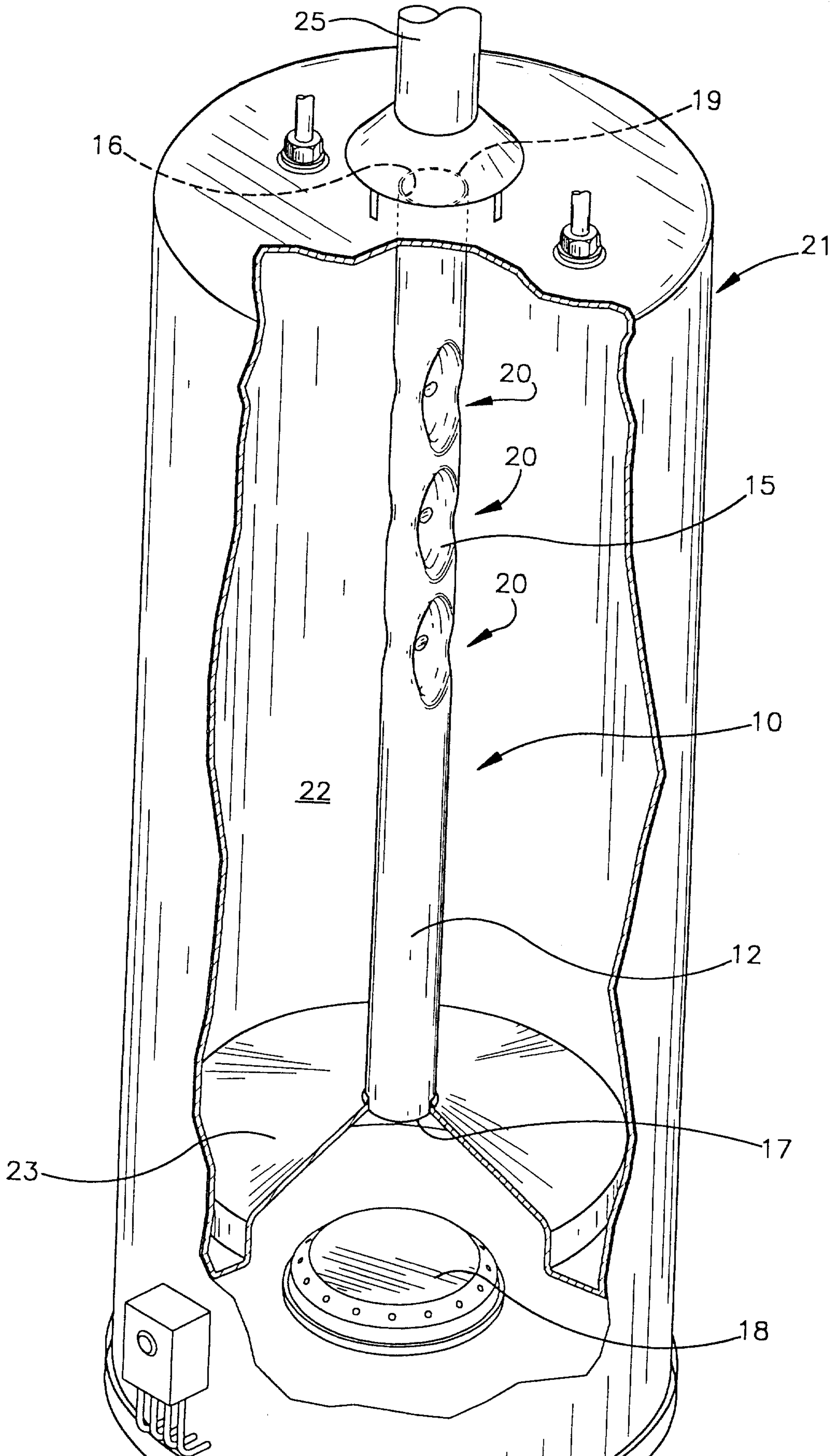
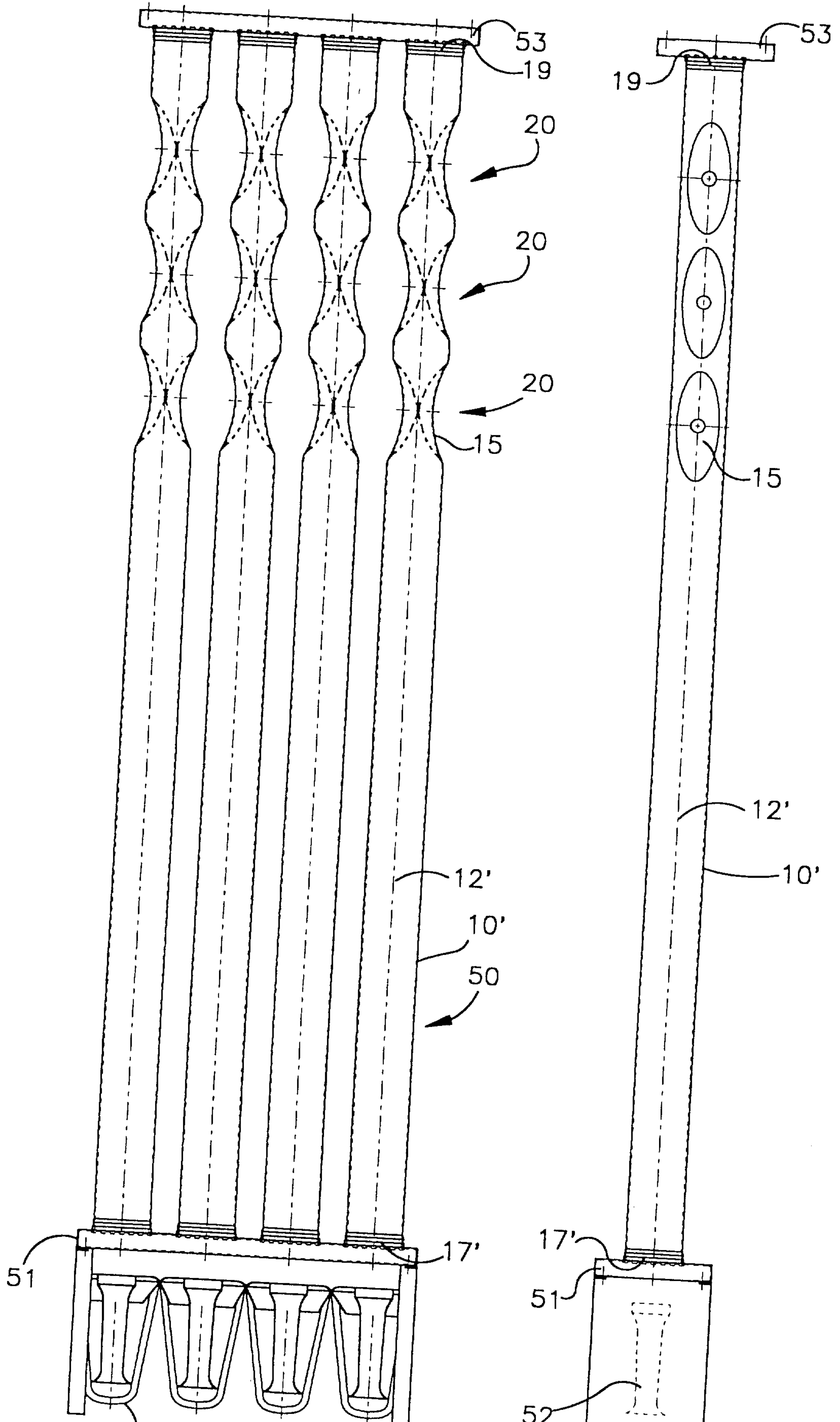
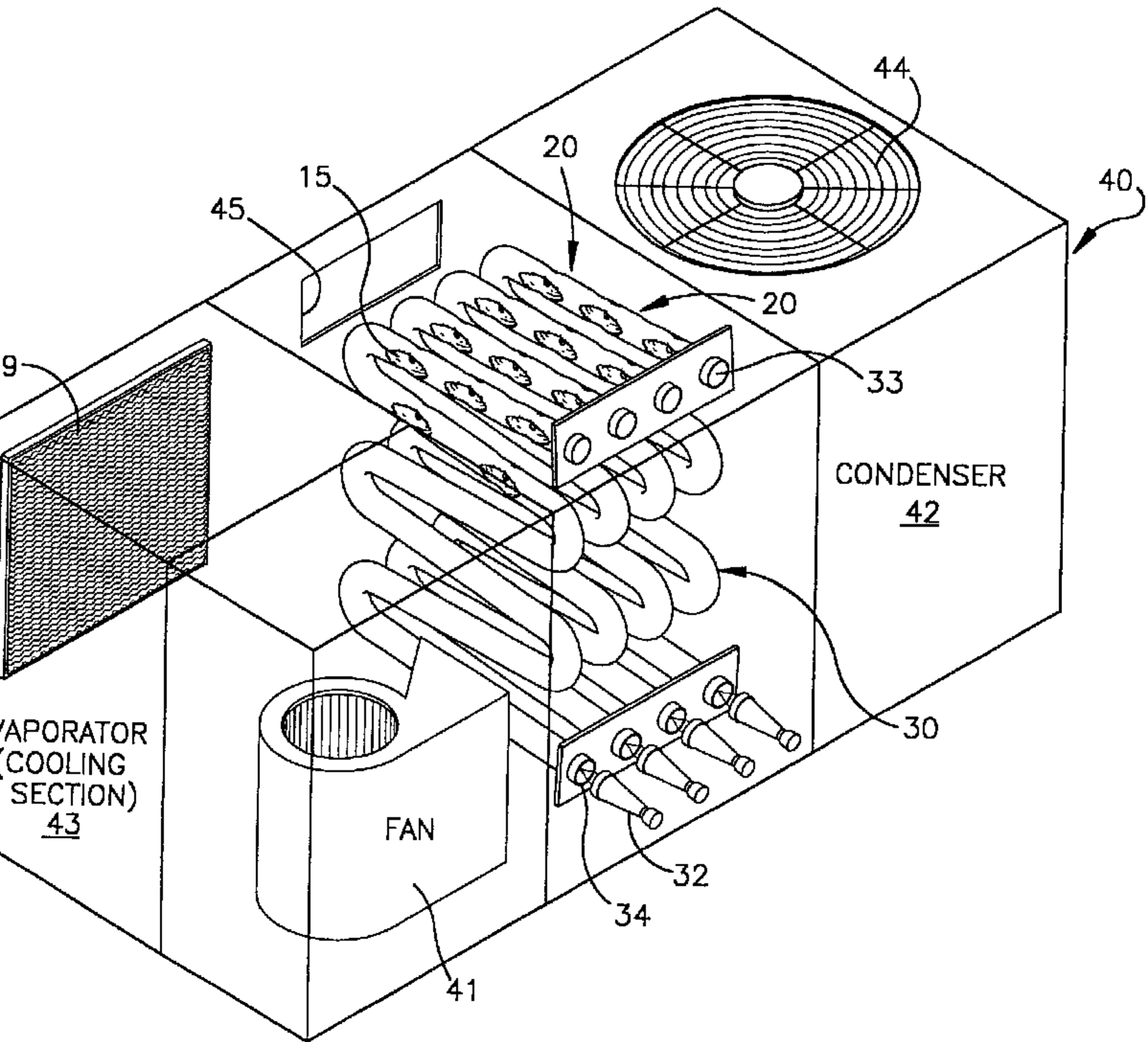

Fig.6

Fig.5







EVAPORATOR
(COOLING
SECTION)
43

CONDENSER
42

FAN

CONDENSER
42

FAN