

May 28, 1935.

G. E. GAGNIER

2,002,535

GRIP FOR HANDLES

Filed Sept. 14, 1932

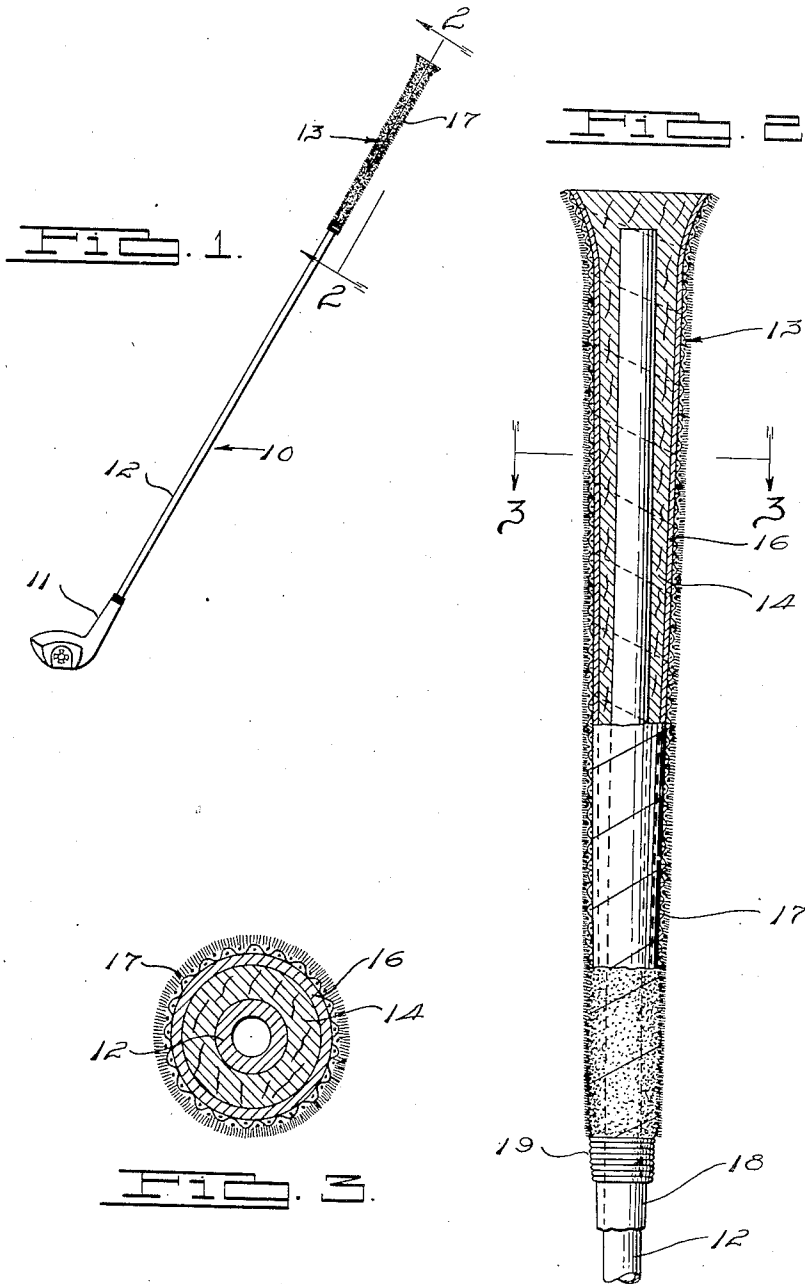

INVENTOR
George E. Gagnier
BY
Harned, Wickey, Pierce & Harris
ATTORNEYS.

UNITED STATES PATENT OFFICE

2,002,535

GRIP FOR HANDLES

George E. Gagnier, Detroit, Mich.

Application September 14, 1932, Serial No. 633,147

3 Claims. (Cl. 273-81)

The invention relates to coverings or grips for handles of various kinds such, for example, as are employed on golf clubs, tennis rackets, baseball bats, axle handles, steering wheels, etc.

5 An object of the invention is to provide a firm, comfortable grip on the handle of any object adapted to be actuated by force applied with the hands and which will not be undesirably affected by water, perspiration, heat or other natural causes.

10 Another object of the invention is to provide a grip which will not slip or twist in the hands and which can be held firmly with the hands relaxed to the maximum extent consistent with the holding of the grip.

15 Another object of the invention is to provide a resilient grip capable of conforming to the contour of the hands to a slight extent but resisting deformation to any great extent when it is desired to apply any large amount of force to obtain immediate response to the movement of the hands.

20 The embodiment of the invention disclosed for the purpose of illustration comprises a golf club, the handle of which is spirally wrapped with an impregnated fabric strip and which is held on the handle either by adhesive material, cords or by other suitable means now generally employed for this purpose.

25 The idea may be employed in the covering of handles with fabric of any desired weave and made of either vegetable or animal fibers as, for example, cotton, mohair, rayon or other fibrous materials possessing the desired properties. In impregnating the fabric for the grip, any solution may be employed which will give the fabric a tenacious and resilient quality and which will cause the fabric to cling to the hands upon the application of the slightest force. A solution of latex or other rubber-like material is considered particularly applicable for impregnating the fabric inasmuch as it can be vulcanized directly to the handle without the necessity for the employment of cement or other fastening means.

30 In the drawing:

35 Fig. 1 is an elevational view of a golf club having a handle embracing the principles of the invention.

40 Fig. 2 is a longitudinal sectional view of part of the golf club illustrated by Fig. 1 as the handle might appear substantially along line 2-2 of Fig. 1.

45 Fig. 3 is a cross-sectional view of the handle taken substantially on line 3-3 of Fig. 2.

50 The golf club 10, selected for the purpose of

illustrating the invention, comprises a golf club head 11 having a tubular metallic or other suitable shaft 12 connected at one end thereto and the opposite end of which is formed to provide a handle 13. In the present instance the handle is formed by surrounding the upper end of the tubular shaft with a properly shaped piece of wood or other suitable supporting material and around which is tightly wrapped in spiral formation a strip of leather, friction tape or other fibrous strip material such as that indicated at 16. The outside of the surface thus formed is covered by spirally winding thereon a strip of pile fabric 17 or other relatively resilient material. It is preferable to wind the fabric along the handle with the pile side of the material disposed outwardly thereof to be directly engaged by the hands in gripping the handle. The fabric strip and outwardly extending pile may be impregnated with a latex or other suitable solution either before it is wound upon the club handle or the solution may be applied to the fabric with the latter already in the position described. If the latter method of applying the handle is practiced, the latex solution may be vulcanized upon the fabric by the application of heat to the entire handle and during which process the fabric also may be made to adhere to the supporting structure therebeneath. If it is desired to employ a solidifying coating or shell, such as illustrated at 18, upon the outside of the shaft 12, this also may be permanently bonded to the shaft during the vulcanization of the latex impregnated fabric.

35 If it is desired to apply a grip to a golf club already provided with a leather grip, for example, the material for such covering may be prepared by impregnating and vulcanizing a sheet or fabric strip suitable for the purpose and then applying the strip to the outside of the handle, either upon or after removing the leather grip already provided, by employing any suitable cement for holding the fabric material in place.

45 The end of a fabric strip may be fastened either temporarily or permanently by the employment of a cord indicated at 19 which is wound spirally over the lower end of the fabric and a portion of the shaft adjacent thereto. If it is desired to leave this fastening device permanently on the club, it can be rendered almost entirely indestructible by also impregnating the cord with latex which can be vulcanized when the latex impregnated fabric strip is vulcanized. The solidified latex in the cord will hold the

convolutions thereof closely together and will prevent the cord from becoming loosened even though many of its convolutions are severed.

When employed for any purpose, a grip embracing the features herein disclosed has a very comfortable and responsive feeling to the hands and will cling to the hands during use notwithstanding perspiration on the hands or that the grip may not be rigidly held. During a rain, for example, a golf club equipped with such a grip may be used without any more danger of slipping from the hands than there would be on a perfectly dry day. The rain does not adhere to the grip to any appreciable extent and, although it does adhere to the hands, the club can be held just as securely with wet hands as it can be with dry hands.

It is to be understood that the structure embracing the invention can be made by other processes than herein disclosed and may have many modified and equivalent forms and applications all within the spirit of the invention and the scope of the appended claims.

I claim:—

1. A handle for operation by the hands comprising a centrally disposed support, a pile fabric covering for said support, said covering being disposed on said support with the pile of said fabric extending outwardly and said fabric and outwardly extending pile being impregnated with a tenacious rubber-like substance.

2. A handle for operation by the hands comprising a centrally disposed support, a pile fabric covering for said support, the pile of said fabric being disposed outwardly relative to said support, and said fabric and outwardly extending pile being impregnated with a latex solution for coating the fibrous structure of said fabric and for securing said covering upon said support.

3. A handle for golf clubs comprising a centrally disposed shaft, and a pile fabric covering said shaft and having the pile side thereof disposed outwardly, the thread-like elements constituting the pile being thinly coated with rubber material.

GEORGE E. GAGNIER.