



INTERNATIONAL APPLICATION PUBLISHED UNDER THE PATENT COOPERATION TREATY (PCT)

<p>(51) International Patent Classification <sup>7</sup> : <b>H04L 12/56, 29/06</b></p>	<p><b>A1</b></p>	<p>(11) International Publication Number: <b>WO 00/28705</b> (43) International Publication Date: 18 May 2000 (18.05.00)</p>
<p>(21) International Application Number: PCT/US99/22943 (22) International Filing Date: 13 October 1999 (13.10.99) (30) Priority Data: 09/189,206 10 November 1998 (10.11.98) US (71) Applicant: ODYSSEA SYSTEMS, INC. [US/US]; Suite 218, 2560 Ninth Street, Berkeley, CA 94710 (US). (72) Inventors: FAWAZ, Ayman; 785 Cragmont Avenue, Berkeley, CA 94708 (US). WALRAND, Jean; 31 Parnassus Road, Berkeley, CA 94708 (US). (74) Agents: WOLFELD, Warren, S. et al.; Fliesler, Dubb, Meyer &amp; Lovejoy, LLP, Suite 400, Four Embarcadero Center, San Francisco, CA 94111-4156 (US).</p>		<p>(81) Designated States: JP, European patent (AT, BE, CH, CY, DE, DK, ES, FI, FR, GB, GR, IE, IT, LU, MC, NL, PT, SE).  <b>Published</b> <i>With international search report.</i></p>

(54) Title: METHOD AND APPARATUS FOR INTERCONNECTION OF PACKET SWITCHES WITH GUARANTEED BANDWIDTH

(57) Abstract

A packet-switched communication network in accordance with the invention provides a guaranteed minimum bandwidth between pairs of Packet Switches by defining Service Level Agreements (SLAs). An SLA is defined by at least a source identifier, a destination identifier, and a minimum data rate although other information can also be used. Upon arrival at certain networked nodes, packets are classified according to an SLA by reading the source and destination addresses in the packet. Once classified, the packets are placed in a queue and scheduled for transmission. A scheduler ensures that packets are transmitted at the minimum defined data rate for the SLA. The scheduler may use a statistical multiplexing

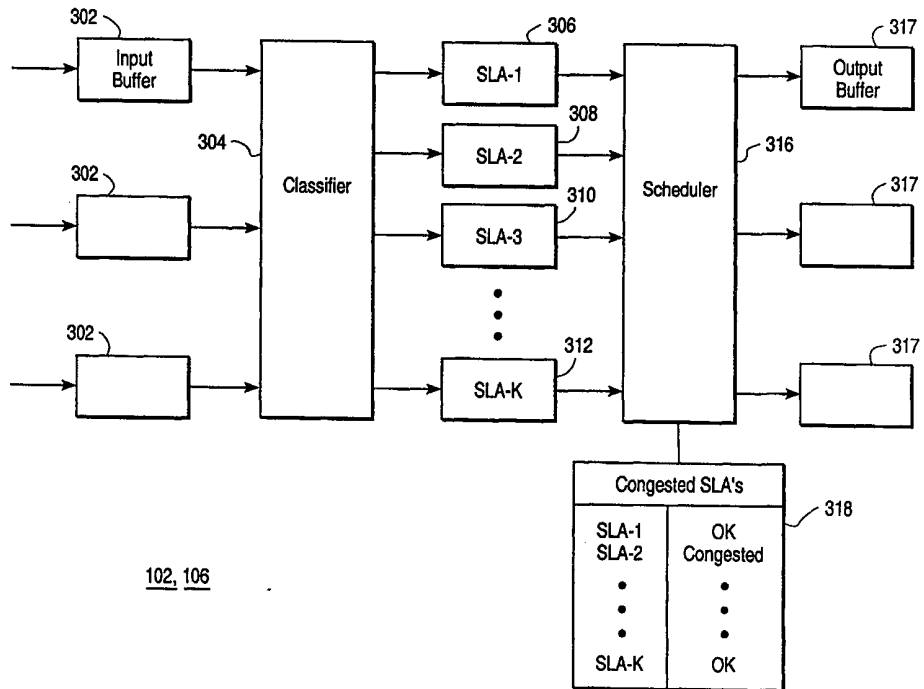

102, 106

method, such as deficit round robin, or deficit golden ratio, which is part of the present invention. The deficit golden ratio method assures a minimum rate to packets for a particular SLA, but minimizes jitter and delay. Further, the present invention implements congestion control that does not require nodes to be entirely turned off in congested conditions.

**FOR THE PURPOSES OF INFORMATION ONLY**

Codes used to identify States party to the PCT on the front pages of pamphlets publishing international applications under the PCT.

AL	Albania	ES	Spain	LS	Lesotho	SI	Slovenia
AM	Armenia	FI	Finland	LT	Lithuania	SK	Slovakia
AT	Austria	FR	France	LU	Luxembourg	SN	Senegal
AU	Australia	GA	Gabon	LV	Latvia	SZ	Swaziland
AZ	Azerbaijan	GB	United Kingdom	MC	Monaco	TD	Chad
BA	Bosnia and Herzegovina	GE	Georgia	MD	Republic of Moldova	TG	Togo
BB	Barbados	GH	Ghana	MG	Madagascar	TJ	Tajikistan
BE	Belgium	GN	Guinea	MK	The former Yugoslav Republic of Macedonia	TM	Turkmenistan
BF	Burkina Faso	GR	Greece	ML	Mali	TR	Turkey
BG	Bulgaria	HU	Hungary	MN	Mongolia	TT	Trinidad and Tobago
BJ	Benin	IE	Ireland	MR	Mauritania	UA	Ukraine
BR	Brazil	IL	Israel	MW	Malawi	UG	Uganda
BY	Belarus	IS	Iceland	MX	Mexico	US	United States of America
CA	Canada	IT	Italy	NE	Niger	UZ	Uzbekistan
CF	Central African Republic	JP	Japan	NL	Netherlands	VN	Viet Nam
CG	Congo	KE	Kenya	NO	Norway	YU	Yugoslavia
CH	Switzerland	KG	Kyrgyzstan	NZ	New Zealand	ZW	Zimbabwe
CI	Côte d'Ivoire	KP	Democratic People's Republic of Korea	PL	Poland		
CM	Cameroon	KR	Republic of Korea	PT	Portugal		
CN	China	KZ	Kazakstan	RO	Romania		
CU	Cuba	LC	Saint Lucia	RU	Russian Federation		
CZ	Czech Republic	LI	Liechtenstein	SD	Sudan		
DE	Germany	LK	Sri Lanka	SE	Sweden		
DK	Denmark	LR	Liberia	SG	Singapore		
EE	Estonia						

- 1 -

**METHOD AND APPARATUS FOR INTERCONNECTION OF  
PACKET SWITCHES WITH GUARANTEED BANDWIDTH**5                    CROSS-REFERENCE TO RELATED APPLICATIONS

The present application is related to Application Serial No. 09/189,347, filed November 10, 1998, entitled "Method and Apparatus to Reduce Jitter in Packet Switched Networks and to Application Serial No. 09/189,819, filed November 10, 1998, entitled "Method and Apparatus to Minimize Congestion in a Packet  
10 Switched Network," both incorporated by reference herein.

FIELD OF THE INVENTION

The present invention relates to communication networks, and particularly, the present invention relates to providing guaranteed quality of service in a packet  
15 switched network.

BACKGROUND OF THE INVENTION

In communications technology, there is an ever-increasing demand for high-performance networks, and in particular, a demand for high-performance Internet  
20 access. This increased demand has led to the development of improved networks capable of handling larger volumes of data with smaller delays. Nonetheless, these improved networks each have their own shortcomings.

Communications networks like the Internet are generally formed with a number of transmission links interconnected with switches. A transmission link is  
25 any medium through which signals are communicated and can be single or multiple twisted pairs, optical fiber, coaxial cable, radio links, or other mediums. A switch is a device with one or more input ports and one or more output ports. The switch directs bits arriving at an input port to the appropriate output port. Switching in communications is accomplished using one of two methods: circuit switching and  
30 packet switching.

- 2 -

Circuit switching has been used since the birth of the modern telephone system. Circuit switching entails establishing an end-to-end connection between two points before any information is communicated. A telephone connection is one example of a circuit-switched connection. In early circuit-switched networks, information could only be communicated over the links if the links were not being used by another party and if an end-to-end connection was already established.

To make the circuit-switched network more economical, Time Division Multiplexing (TDM) was developed. TDM is a method that enables multiple end-to-end connections to share the same link. More specifically, using TDM the respective data streams are transmitted for a designated time period in a round robin fashion over a shared transmission link. For instance, referring to the illustration of Fig. 1, to multiplex N data streams using TDM, the first stream is transmitted for T(1) seconds, then the second stream for T(2) seconds, and so on until the N-th stream is transmitted for T(N) seconds. The cycle then repeats starting again with the first stream. Hence, each data stream gets a fraction of the total transmission rate for the shared link, i.e., the stream i (i = 1, . . . , N) gets a fraction

$$\frac{T(i)}{[T(1)+T(2)+\dots+T(N)]}$$

of the transmission rate of the link. So, using TDM, a link with transmission rate R is capable of carrying data streams with rate R(1), ..., R(N) provided that R(1) + ... + R(N) is less than R. Therefore, a circuit-switched network with TDM provides a guaranteed bandwidth to a connection from the source of the connection to its destination.

Despite the ability to send multiple data streams through a shared link at a guaranteed rate for each data stream, when a particular data stream does not need its time slot on the link, that fraction of the link capacity is wasted because other data streams are not permitted to use that time slot. Thus, although the circuit-

- 3 -

switched network offers the user guaranteed bandwidth available at any time, when the user is not utilizing its allocated bandwidth, the link lays idle for the user's time slot – unavailable for use by any other party, leading to an inefficient utilization of available resources.

5           Even though there are inefficiencies inherent in circuit switching, such switching has proven satisfactory to carry voice data. Non-voice data, however, tends to be more “bursty” in nature. Hence, when a data burst arrives, having to wait through TDM cycles for transmission will make the transmission of data appear slow — an appearance that might be avoided if all resources were available  
10           for use.

          To avoid the inefficiencies of circuit switching, the communications industry has made a shift to “packet switching” for non-voice type data transmission. Packet switching does not establish a single end-to-end connection for each data stream. Rather, the data stream is divided into “packets,” each of which carries data as well  
15           as various identifying information about each packet. Such identifying information includes routing information, for instance, source and destination addresses for the packet. When a packet arrives at a switch, it is stored in a buffer. The switch looks at the routing information in the packet and routes the packet to the appropriate  
20           output port. The packets are then forwarded one “hop” (or switch) at a time, until they reach their destination. Each packet in a particular data stream does not necessarily follow the same path to its destination as the others.

          In most networking protocols, the networking system is hierarchically divided into subnetworks that are interconnected. The nodes (e.g., personal computers) in each subnetwork are addressed by a “Layer 2” address (sometimes  
25           called a MAC address). A subnetwork delivers packets between any two of its nodes. These packets are labeled with the Layer 2 addresses of the source and destination nodes of the subnetwork.

          Subnetworks can also be interconnected to one another with the use of specialized switches. These switches determine how to handle a packet based either

- 4 -

on the Layer 2 addresses in the packet or on some other routing information. For instance, a switch interconnects a number of subnetworks through its several ports. For each of its ports, the switch maintains a list of Layer 2 addresses of the computers of the subnetwork(s) that is(are) attached to the port. When the switch  
5 receives a packet, the switch checks the port lists and identifies the port that is connected to the Layer 2 address for the destination of the packet. The switch then transmits the packet on that identified port. Other networking protocols additionally add special routing information in each packet. That routing information may be a connection number or a pair of geographically arranged  
10 addresses, as in the case of the Internet Protocol.

Since packets from different data streams are all routed over the same transmission lines, a scheduling method by which to place the packets from the different streams onto the transmission lines is required. One such scheduling method is statistical multiplexing (SM). In contrast with TDM, SM does not  
15 allocate fixed periodic fractions of the transmission rate of the link to the different data streams. Instead, the SM schedules packets for transmission depending on the actual needs of the different data streams. In its simplest form, illustrated in Fig. 2, statistical multiplexing schedules packets on the transmission line in the order of their arrival at the switch, i.e., on a first come, first served basis. Although such a  
20 scheduling method does not waste communication resources, it cannot guarantee a minimum transmission rate for any particular data stream. The packets simply get to their destination when they get there.

A variation of SM called "deficit round robin" (DRR) can provide better transmission rate guarantees and is illustrated in Fig. 3. Under DRR, to multiplex  
25  $N$  data streams,  $N$  integers  $W(1), \dots, W(N)$ , are first chosen as a weight ( $W$ ) for each data stream. Then for the first data stream (DS1) up to  $W(1)$  bits are transmitted. If all of the packets of DS1 are transmitted before transmitting  $W(1)$  bits or if bit  $W(1)$  is the last bit of a packet, then a second integer  $D(1)$  is set to 0. But if bit  $W(1)$  is not the last bit of a packet, then additional bits are sent until the

- 5 -

transmission of the packet is completed, and  $D(1)$  is set to equal the number of additional bits sent. The procedure is repeated for data streams  $DS_2, \dots, DS_N$  with the corresponding numbers  $W(2), D(2), \dots, W(N), D(N)$ . The cycle then repeats starting with  $DS_1$ , but  $W(1)$  is replaced with  $W(1) - D(1)$ . Hence,  $W(1) - D(1)$  bits are transmitted instead of  $W(1)$  (in other words,  $D(1)$  represents a “deficit” of  $DS_1$ ). If there are additional bits remaining in a packet, then those  $D'(1)$  additional bits are sent. The procedure is again repeated for  $DS_2, \dots, DS_N$  in a similar manner. When the procedure returns again to  $DS_1$ ,  $W(1) - D'(1)$  will replace  $W(1)$ .

10 Therefore, using DRR, a minimum transmission rate for a data stream  $DS_i$  (where  $i = 1, \dots, N$ ) will generally be the fraction

$$\frac{W(i)}{[W(1)+W(2)+\dots+W(N)]}$$

of the transmission rate for the link. Moreover, if some data streams do not need their guaranteed allocation, then the other connections can utilize the unused resources and will do so automatically. Many variations of DRR are known in the art, including Weighted Fair Queuing (WFQ), Generalized Processor Sharing (GPS), and Class Based Queuing (CBQ).

15 Despite DRR's ability to generally provide some minimum transmission rate, the capacity for the transmission of data at a particular rate is still not reserved like it is in circuit-switched networks. Hence, there is still the possibility that delivery of a message will be delayed. Therefore, most data communication service providers, although they utilize statistical multiplexing for packet transmission, will not guarantee any minimum quality of service. “Quality of service” refers herein to a minimum bandwidth provided between two points, A and B.

20 The advent of Asynchronous Transfer Mode (ATM) seems to combine the benefits of statistical multiplexing with the guaranteed quality of service of circuit switching. While ATM sends data in packets, or cells, ATM sets up a “virtual

- 6 -

channel" before transmitting any data. All of the frames follow the same route along the virtual channel, thereby guaranteeing the order of cell arrival. Further, because data is sent in cells, these cells can be statistically multiplexed, and can use all available resources efficiently while guaranteeing a minimum quality of service.

5 To allow all incoming data streams access to a shared link, ATM monitors the number of packets or cells received from a particular data stream. If the number received during a time interval exceeds a threshold designated for the incoming data stream, then packets/cells are discarded.

10 Nonetheless, ATM is a complicated protocol and expensive to implement, requiring complex hardware and network management software. Further, in addition to setting up and maintaining virtual channels, ATM requires the reformatting of received data packets into special ATM cells that include a virtual channel identifier and a virtual path identifier unique to ATM. So while ATM has been used by telephone service providers, because of its expense and complexity it is not generally used for Internet or other data communications.

15 Therefore, a simplified system and method for providing a guaranteed quality of service for Internet and other packet-switched data communications is desirable.

20

### SUMMARY OF THE INVENTION

In order to overcome the deficiencies in communication networks described above, a system and method in accordance with the invention provides a simple, yet flexible packet-switching system that can guarantee quality of service between two points. In particular, such a system includes a plurality of linked nodes. Packet Switches, such as standard routers, are coupled to the nodes.

25

Service Level Agreements, or SLA's, are defined between pairs of Packet Switches and guarantee a minimum quality-of-service (minimum bandwidth) between the two packet switches. When a packet arrives at a node from a packet



- 7 -

switch, the node inspects certain classification information contained within the packet. In one embodiment, such classification information is the source and destination identifiers (e.g., addresses) of the packet, while in other embodiments classification information additionally includes other information. Using the  
5 classification information, the packet classifies the packet with an SLA. A scheduler in the node ensures that packets from each SLA are scheduled for transmission at least the minimum data rate corresponding to the SLA.

In one embodiment, each SLA has its own queue in the node. In such an embodiment, a scheduler schedules the packets for transmission using a statistical  
10 multiplexing method. In one embodiment, such a method is a DRR method. In another embodiment, such a method is a modified DRR method referred to herein as a "Deficit Golden Ratio" (DGR) method. A DGR method in accordance with the invention, redistributes the order of the packets that would otherwise be output using a DRR method, thereby eliminating jitter and delay often caused by DRR  
15 scheduling.

In a second embodiment, the SLA's served by a node share a queue. In other words, all packets, no matter which SLA they are classified with, are placed in the same queue. However, a statistical multiplexing scheduling method referred to herein as SLA Early Discard is utilized to ensure the minimum bandwidth of all  
20 SLAs. If the number of packets in the queue for a particular SLA have reached or exceeded a threshold value, then no additional packets for that particular SLA are added to the queue. Any newly arriving packets for the SLA are discarded. If the packets for the particular SLA have not reached the threshold, then additional packets for that SLA can be added to the queue.

25 In addition to classification and scheduling, nodes in accordance with the invention further implement congestion control. When packets for a particular SLA are transmitted at a rate higher than the minimum rate designated for the particular SLA, then downstream nodes receiving those packets may become congested. In one embodiment, those downstream nodes provide messages to the upstream nodes

- 8 -

indicating that the rate of transmission for packets from the particular SLA should be reduced. In some embodiments, the node may turn off service for the particular SLA while it is congested. However, service to the other SLA's remains turned on in the node.

5           Thus, a system and method in accordance with the invention can provide service to users akin to leased lines in a circuit switched system, although the system and method described herein is for packet switching. Moreover, such service can be provided without reformatting data packets as is done in ATM. In one  
10           embodiment, the nodes in accordance with the invention have ethernet interfaces and accept and forward ethernet packets without change. Hence, standard packet switches "see" a network in accordance with the invention as an ethernet-type network. Finally, such guaranteed quality-of-service can be provided with minimal additional hardware and software unlike other conventional networking methods such as ATM.

15

#### BRIEF DESCRIPTION OF THE DRAWINGS

          The present invention is described with respect to particular exemplary  
20           embodiments thereof, and reference will be made to the drawings, which are not necessarily drawn to scale and in which:

          Fig. 1 is a representational block diagram illustrating time division multiplexing;

          Fig. 2 is a representational block diagram illustrating first-come, first-served statistical multiplexing;

25           Fig. 3 is a representational block diagram illustrating deficit round robin scheduling;

          Fig. 4 is a functional block diagram representing a network in accordance with the invention;

          Fig. 5 is a block diagram illustration of an ethernet frame;

- 9 -

Fig. 6 is a functional block diagram of a node in accordance with the invention;

Fig. 7 is a representational block diagram illustrating deficit golden ratio scheduling in accordance with the invention;

5 Fig. 8 is a functional block diagram of a second embodiment of a QoS node in accordance with the invention;

Fig. 9 is a representational block diagram of packets input into a QoS node and packets output from the node using SLA early discard in accordance with the invention;

10 Figs. 10, 11, and 12 illustrate, in block diagram format, congestion control in accordance with the invention; and

Figs. 13(a) and 13(b) are functional block diagrams representing reconfiguration of a ring in accordance with the invention.

15 DETAILED DESCRIPTION

A system and method in accordance with the invention provides a simplified method of packet-switched data communications with a guaranteed minimum bandwidth between any two given points. Although a system and method in accordance with the invention is packet-switched, it can provide service much a like  
20 a leased line in circuit-switched networks. Still, a system in accordance with the invention is not inefficient with its resources as circuit-switched networks are.

In order to provide a guaranteed bandwidth on a packet-switched data communication system, a system and method in accordance with invention utilizes two elements: (1) packet classification and (2) packet scheduling. In some  
25 embodiments an additional third element, (3) distributed back pressure, is also utilized. Each of these elements will be described below. But first, a general overview of the network to be used in accordance with the invention is given.

Fig. 4 shows a generalized functional block diagram of a network 100, incorporating an embodiment of the invention. As shown in Fig. 4, network 100

- 10 -

includes a number of nodes 102, which are interconnected to form a ring 104. The nodes 102 on the ring 104 are sometimes referred to herein as "ring nodes." In one embodiment, ring 104 is formed with dual rings, which will be described in more detail later. Coupled to many of the ring nodes 102 are other nodes 106, sometimes referred to herein as "multiplexing nodes." Other than their location on or off of ring 104, ring nodes 102 and multiplexing nodes 104 are substantially the same. In Fig. 4, both types of nodes are denoted by a circle, "O", and are generically referred to herein as "Quality of Service Nodes" or "QoS Nodes."

In one embodiment, the QoS Nodes 102, 106 include ethernet interfaces that operate at 1Gbps. In other embodiments, however, the nodes may operate at a different rate (e.g., 10 Mbps, 100 Mbps, OC12, OC48, OC96, OC192). Moreover, some QoS Nodes may operate at one rate while other QoS Nodes operate at a second rate. Hence, the actual rates for either of the types of QoS Nodes are not intended to be restricted by the invention nor are the interfaces utilized.

Further, the actual links between the QoS Nodes can be formed in any manner known to those of skill in the art. For instance, the links interconnecting the QoS Nodes can be built from single or multiple twisted wire pairs, optical fibers, or coaxial cable. In other embodiments, the links can be radio links, or even free space infrared links. In addition the protocol used by the links may be based on Gigabit Ethernet, ATM, WDM, SONET, or other technology.

Fig. 4 further illustrates the plurality of packet switches 108, denoted with a square symbol, "□". The packet switches are similar to those known by persons of ordinary skill in the art. For instance, packet switches can be routers with standard ethernet interfaces such as those made by Cisco Systems or Nortel Networks. The packet switches are attached either directly to ring 104 via a ring node 102, or indirectly to the ring 104 via a multiplexing node 106. Each packet switch 108 is in turn coupled to a number of LANs or other subnets 110, denoted by an "X" indicator (only a few subnets are illustrated).

- 11 -

As used herein, "packet switches" 108 denote standard packet switches, which are known in the art and include devices such as routers. Ring nodes 102 and multiplexing nodes 106, although technically packet switches (since they route incoming packets to output ports), are distinguishable from standard packet switches, and are referred to herein as "Quality of Service Nodes" or "QoS Nodes."

#### Packet Classification and Scheduling

In accordance with the invention, a minimum quality of service (a minimum bandwidth) is provided between selected pairs of packet switches, such as from A to B, B to A, or from A to C. The quality of service for a particular packet switch pair is referred to herein as a Service Level Agreement, or SLA. Each SLA includes at least three elements: a source packet switch, a destination packet switch, and a minimum data rate for data transfers between the two packet switches. For instance, referring again to Fig. 4, an SLA may be, for example, a 128-kbps connection between A and B.

In one embodiment of the invention, the packets received at each QoS Node 102, 106 from a packet switch 108 are ethernet frames, which specify the Layer 2 address of the source packet switch and the Layer 2 address of the destination packet switch. A standard ethernet frame is shown in Fig. 5. A frame includes a preamble field, a start-of-frame (SOF) field, a destination address field, a source address field, a length of data field, a data field, a pad field, and a checksum field. These as well as the other fields are well documented and known in the art, however, the destination and source address fields are of more importance with respect to the present invention. Thus, in one embodiment of the invention, the QoS Nodes operate at Layer 2 with ethernet frames.

Although ethernet frames (packets) are frequently referred to herein, other types of packets could be utilized in other embodiments of the invention. Hence, ethernet packets are used for purposes of illustration only, and such illustration is not intended to limit the scope of the invention.

- 12 -

### First Embodiment

A first embodiment of a node 102, 106 is shown in Fig. 6. Upon arrival at a QoS Node 102, 106, packets (e.g., ethernet frames) are placed into an input buffer 302. Subsequently, classifier 304 classifies each packet in accordance with an SLA. To do so, classifier 304 reads at least the source and destination identifier of the packet to be classified, for instance, Layer 2 ethernet frame addresses. The classifier 304 then correlates the pair of identifiers with a corresponding SLA. In one embodiment, such source and destination identifiers are physical addresses, while in other embodiments such source and destination addresses may be composed of other information.

In addition to source and destination identifiers, other embodiments of the invention may utilize other information for packet classification. For instance, the type of application (e.g., e-mail) from which the packet originated can additionally be used to classify packets with an SLA. Thus, the information used for classifying packets is referred to herein as "classification information."

In one embodiment of the invention, once an SLA has been identified for the packet using the various classification information, the packet is placed into a FIFO-type buffer 306-312 that corresponds to the SLA, forming a queue of packets for the SLA. Unlike ATM and other protocols, the packets do not need to be reformatted or modified in any way.

Once the packets have been classified according to their SLA, the packets are scheduled for transmission by scheduler 316 and placed in an appropriate output port 317. For purposes of continued discussion, the scheduling methods used herein are discussed with reference only to a single output port, although it is to be understood that a QoS Node could have more than one output port.

In order to guarantee quality of service for each SLA, a scheduler in one embodiment of the invention uses the Deficit Round Robin (DRR) scheduling method described previously with respect to Fig. 3. With DRR, the rate (R) of the link times the weight (W) for a particular data stream divided by the sum of weights

- 13 -

is greater than or equal to the bandwidth for the particular data stream. In other words,

$$\frac{RW(i)}{W(1)+W(2)+\dots+W(N)} \geq \text{bandwidth.}$$

Therefore, using the DRR scheduling method, a minimum quality of service for each SLA can be guaranteed.

5           Nonetheless, DRR may introduce delay and/or jitter into the bit stream, particularly when there are many queues. In other words, during the time that bits for SLA-1 are being sent, bits from the other SLA's must wait. Likewise, once SLA-1's turn has passed, no bits will be sent from SLA-1 until bits from all of the other participating SLA's have been sent. Such wait times may be unacceptable for  
10 some applications.

          Therefore, in accordance with one embodiment of the invention, a new scheduling method is utilized, referred to herein as the Deficit Golden Ratio (DGR) method. To reduce jitter, DGR schedules the bits in a similar manner to that done for DRR, but rather than imposing wait times, the DGR method interleaves bits  
15 from each of the SLA queues. The distribution is performed utilizing the Golden Ratio:

$$\frac{\sqrt{5}-1}{2} \approx 0.62.$$

          More specifically, much as with DRR, the order of transmission for DGR is constructed utilizing the weights  $W(k)$  (in bits) assigned to each SLA- $k$ ,  $k = 1, \dots, K$ . An integer  $P(k)$  is then set to equal the integer part of  $W(k)/1000$ . Since  
20 the average packet length in Internet Protocol (IP) applications is about 1000 bits,  $P(k)$  is approximately the average number of packets of SLA- $k$  that DRR would serve in one cycle. In other embodiments,  $P(k)$  can be found using a denominator other than 1000, for instance, if an average packet length is a different value.

The DGR scheduler constructs a packet sequence {packet-1, ..., packet-P} for transmission, where  $P = P(1) + \dots + P(K)$ . The packet sequence is chosen so that there are  $P(k)$  packets from SLA-k in the sequence. The sequence is selected so that the packets from each SLA are distributed in the sequence. The sequence is constructed as follows.

First, the successive decimal parts of the first P multiples of 0.62 (the golden ratio) are calculated by the scheduler. By way of example, if  $P(1) = 3$ ,  $P(2) = 1$ ,  $P(3) = 2$ , then  $P = 6$ , and the decimal parts of the first six multiples of 0.62 are set forth in Table 1 below:

10

TABLE 1

Multiple	Decimal Part
0	0.00
1	0.62
2	0.24
3	0.86
4	0.48
5	0.10

15

The scheduler sequentially groups these multiples into groups corresponding to each SLA-k, where each group has  $P(k)$  sequential multiples. Continuing the above example, since  $P(1) = 3$ , then SLA-1 is designated the first three multiples, SLA-2 will receive the next one multiple since  $P(2) = 1$ , and since  $P(3) = 2$ , SLA-3 receives the last two multiples. The designated decimal parts of the multiples are shown in Table 2 below:

25



TABLE 2

SLA	Designated Decimal Parts of N multiples of 0.62
SLA-1	0, 0.62, 0.24
SLA-2	0.86
SLA-3	0.48, 0.10

5

To determine the packet sequence, the decimal parts are placed by the scheduler in increasing order, where the designated SLA-k remains correlated to the decimal part. For the example above, such ordering is shown in Table 3:

TABLE 3

Decimal Part	SLA
0.00	SLA-1
0.10	SLA-3
0.24	SLA-1
0.48	SLA-3
0.62	SLA-1
0.86	SLA-2

10

15

The scheduler will output packets from the SLAs according to the re-ordered decimal parts. Hence, Table 3 indicates that the packet sequence output by the scheduler in our example should be from {1, 3, 1, 3, 1, 2}, where the numbers inside the brackets correspond to SLA numbers.

20

Using the sequence above, the DGR scheduler transmits bits from the SLA sequence in a manner similar to DRR. Specifically, the scheduler utilizing a DGR method in accordance with the invention first transmits one packet from the first SLA in the sequence, in the above example, SLA-1 (see Table 3), where this packet has Q(1) bits. If Q(1) is greater than or equal to W(1), then the scheduler sets D(1) = Q(1) - W(1). SLA-1 is then dropped from the rest of the current scheduling cycle

25

- 16 -

(i.e., in the example above, the second and third occurrences of SLA-1 in the Table 3 sequence would be skipped). Otherwise, the scheduler notes that SLA-1 still has  $W(1) - Q(1)$  credits. The scheduler then continues this procedure with the other SLAs in the DGR sequence, e.g., in Table 3 above, SLA-3, then SLA-1, and so on, sending a packet from each SLA unless the SLA has been dropped from the cycle. After it has reached the last SLA in the sequence, the scheduler starts again from the beginning of the sequence and continues to perform the same procedure until all of the SLAs have exhausted all of their credits (i.e., until all SLA's have been dropped from the cycle). At this point, the cycle ends, and the scheduler starts a new cycle with the credits  $W(i)$  replaced by  $W(i) - D(i)$ . Upon exhaustion of all credits by the SLAs, another new cycle starts where the credits allocated to each SLA are  $W(i) - D'(i)$ , and so on. An example output stream is shown in Fig. 7.

In this manner, the DGR scheduling method results in smoother traffic and smaller delays, but still guarantees the bandwidth reserved for the SLA.

It should be understood by those of skill in the art that the classifier and scheduler described above can be implemented in hardware, software, and/or firmware, or any combination thereof.

### Second Embodiment

A second embodiment of a QoS Node 102, 106 is shown in Fig. 8. Rather than having a single queue per SLA, as in Fig. 6, only one queue, an "aggregate queue," is used for all SLA's in Fig. 8. When packets arrive at a QoS Node from various packet switches, the packets are buffered in input buffers 402. The classifier 404 maintains a single first-in, first-out queue in buffer 406 for all the SLA's. The packets are placed in the buffer 406 in the order of their arrival at the QoS Node. The packets, however, are only placed by classifier 404 into the queue if a scheduler allows such placement. Such a scheduler operates in accordance with a scheduling method referred to herein as "SLA Early Discard," and represents a new form of statistical multiplexing.

- 17 -

In accordance with SLA Early Discard, each SLA-k (where  $k=1,\dots,K$ ) is assigned some integer weight,  $M(k)$ . When a packet of SLA-k arrives at the QoS Node 102, 106, the packet is accepted into the queue only if the number of packets for that particular SLA in the queue is less than  $M(k)$ . If the number of packets in the queue for the particular SLA have reached or exceeded  $M(k)$ , then the packet is discarded. For example, if there are three SLA's, if  $M(1) = 3$ ,  $M(2) = 2$ , and  $M(3) = 2$ , and if packets arrive at the node in the following order  $\{1, 2, 1, 3, 2, 1, 1, 3\}$ , then the fourth packet from SLA-1 is discarded. Discarded packets can be resent from the source or otherwise later recovered in a manner known to those of skill in the art. The resulting packet stream is shown in Fig. 9. In other embodiments, the number of bits in the aggregate queue for a particular SLA are monitored instead of the number of packets.

Consequently, if all SLA's are busy, then the packet queue contains about  $M(1)+M(2)+\dots+M(k)$  packets. The link transmits a fraction

$$\frac{M(k)}{M(1)+M(2)+\dots+M(N)}$$

of its packets from SLA-k. Therefore, SLA-k is guaranteed the fraction listed above of the total link bandwidth. Further, packets are only discarded after monitoring the aggregate queue, whereas in ATM, packets are discarded solely on the basis of the source they are from. In ATM, regardless of whether other resources are required by other data streams, packets are discarded upon reaching a threshold for that source during a given time interval. In contrast, the SLA early discard method of the present invention only discards packets if they exceed a percentage of the aggregate queue.

For example, if the total memory (i.e., the number of bits the aggregate queue can store) for a 1 Gbps link is 2 MB, the delay of the QoS Node (the time the packet arrives to the time the packet is transmitted) is approximately 16 ms for each packet. If 2 MB correspond to approximately 16,000 packets with an average

- 18 -

length of 1000 bits per packet, two packets should be allocated for  $M(k)$  for 128-kbps agreement. That is, if SLA-k has a rate equal to  $n \times 128$  kbps,  $M(k) = 2n$  if the port rate is 1 Gbps. If the port rate is  $R$  Gbps then,  $M(k) = 2nR$ . For SLA's that have a rate equal to large multiples of 128 kbps, the fluctuations in packet sizes should not significantly affect the actual guaranteed minimum bandwidth.

It should again be understood by those of skill in the art that the classifier and scheduler for a node described above can be implemented in hardware, software, and/or firmware, or any combination thereof.

In essence, using either embodiment as described above, the SLA's can be equated to virtual leased lines. In other words, although operating in a packet-switched network, minimum bandwidth can be guaranteed between pairs of packet switches. Moreover, such guarantees are provided while still utilizing standard packet switches and without modifying router software. In fact, one embodiment of the invention is compatible with packet switches that include standard Ethernet interfaces. Yet, the frame structure for Ethernet (or other) packets does not need to be modified as they would for SONET and ATM, causing the system to appear to the packet switch as a shared Ethernet. Nor does a system in accordance with the invention require complex hardware and software akin to that required for ATM.

#### Congestion Control

As described above, each node will transmit packets for each SLA at a minimum rate. Nonetheless, the actual rate provided can actually be faster than the minimum guaranteed rate. But if such faster service is provided, the capacity of some links in the network may be exceeded.

Therefore, in addition to the classification and scheduling methods described above, in some embodiments the QoS Nodes may additionally implement a congestion control method herein referred to as Distributed Back Pressure (DBP). To avoid link overflow problems, each QoS Node monitors whether any of its

- 19 -

SLA's are congested and maintains a list of all congested SLA's. Such a list is represented in Fig. 6 at 318 and in Fig. 8 at 418. The status of an SLA is marked as "congested" when the occupancy of the queue corresponding to that SLA exceeds some threshold H. The status is reset to "non-congested" when the occupancy of the queue corresponding to the SLA falls below the threshold H. Periodically, the QoS Node sends a control message to its neighboring QoS Nodes, including a current list of all congested SLA's. Each QoS Node uses these control messages to maintain and update its own list of the congested SLA's. The scheduler (316 in Fig. 6) for each QoS Node then skips (does not schedule any packets from) every SLA queue marked as congested. Alternatively, the QoS Node can simply reduce the rate of transmission for the SLA, e.g., to the minimum guaranteed rates.

Figure 10 shows three streams A, B, C transmitting with rates 0.2, 0.6, and 0.2, respectively, and that share an output port of the first QoS Node 702 that has an output port rate 1. The SLAs for A, B, and C have minimum rates of 0.2 each. However, the scheduler lets stream B be overactive. As a result, the queue for SLA-B in the second QoS Node 703 gets saturated: the five SLAs in node 703 each get a service rate of 0.2 but the input of the queue for the SLA-B in the second QoS Node 703 has rate 0.6. The second QoS Node 703 sends a message to QoS Node 702 indicating that QoS Node 702 should stop transmitting packets from SLA-B or reduce the transmission rate to the minimum guaranteed rate, e.g., 0.6. Hence, backpressure is asserted at the source of SLA-B. Only those SLA queues that are congested are switched off or rate reduced — not the entire QoS Node. In other words, the SLAs for A and C will continue to transmit. In contrast, conventional network flow control techniques actually stops the entire flow from a switch when congestion is detected.

If using an embodiment of the invention such as that as shown in Fig. 8, where both the upstream and downstream nodes use aggregated queues, DBP can still be utilized. Like the embodiment of Fig. 6, the embodiment of a QoS Node in

- 20 -

Fig. 8 provides at least a minimum bandwidth for each SLA. Still, the bandwidth provided is permitted to exceed the minimum, which could cause congestion in the input queues of other QoS Nodes. When congestion does occur on a QoS Node, the congested QoS Node sends a STOP message to the upstream QoS Node indicating that the upstream QoS Node should stop transmitting. After some time, the queue at the congested QoS Node empties and the now uncongested QoS Node informs the source QoS Node to start transmitting again. Alternatively, in another embodiment, rather than sending a STOP signal, the congested QoS Node can inform the source QoS Node to serve the aggregate SLA's at a lower rate, e.g. at the minimum guaranteed rate.

For example, Fig. 11 shows DBP when the data streams A, B, and C share a single queue in QoS Node 703. As in Fig. 10, the SLA's for A, B, and C have minimum rates of 0.2, although the scheduler in QoS Node 702 has allowed SLA-B to transmit at 0.6. QoS Node 703 sends a STOP message to node 702, turning off all the streams from A, B, and C. Eventually, QoS Node 703 indicates that the streams can resume. As a result, A, B, C together get a service rate in QoS Node 702 equal to 0.6. This total rate is divided equally between A, B, and C which then get 0.2 each. Alternatively, in Fig. 12, when the SLAs A, B, and C share a queue in QoS Node 703, QoS Node 703 sends a message to QoS Node 702 to serve at its guaranteed minimum aggregate rate (0.6) instead of turning off.

In addition, each QoS Node in some embodiments of the invention, can also implement an internal flow control. When the occupancy of an output buffer 317 (Fig. 6) exceeds a high threshold, the scheduler 316 marks the SLA's that should be sent to that buffer as congested and skips those queues. When the occupancy of a queue in an SLA buffer 306-312 reaches a maximum value, the QoS Node stops transferring packets from the input buffers 302 to the SLA queue. When an input buffer 302 gets full, the ethernet interface sends a signal to appropriate packet switches to stop sending packets.

- 21 -

The overall effect of this flow control both external and internal to the node is to distribute the cumulative packets from an overactive SLA inside the SLA queues of the QoS Nodes while keeping the other SLA's flowing, until the packet switch itself gets stopped. Accordingly, DBP in accordance with the invention exercises a finer congestion control than conventional flow control that shuts off a link completely instead of stopping only the overly active data streams.

#### Network Bandwidth Management

In order to manage the bandwidth for the various SLA's, a pair of bandwidth managers 112 are included in the network as shown in Fig. 4 with a "Δ" symbol. The bandwidth managers determine if a new SLA can be accepted. For reliability in one embodiment, two bandwidth managers 112 are provided attached to the ring at different ring nodes 102. The bandwidth managers 112 monitor the current ring configuration and network topology and keep track of the bandwidth reserved between any two pairs of packet switches. Using this information, the bandwidth managers compute both the bandwidth utilized and available on each segment of the ring. When a request for a new SLA is made, the bandwidth manager uses these computations and determines if the new SLA can be accommodated.

The bandwidth managers are, in one embodiment, computers operating software to perform the management functions described above. A pair of bandwidth managers are provided for reliability. Other embodiments of the invention, however, could have one or more bandwidth managers.

#### Network Reconfiguration

In some embodiments of the invention, an additional protocol is implemented, referred to herein as a "Fail-Safe Management Protocol" (FSMP). The FSMP protects the network 100 against failure of the links connecting the QoS Nodes as well as failure of the QoS Nodes themselves.

- 22 -

In one embodiment, a network 100 operates with FSMP by including a self-healing physical layer. When a failure occurs in part of the ring, the ring reconfigures itself to avoid the failure. FSMP then detects the reconfiguration and initializes a network status update. Such self-healing is well-known in the art such as in networks using SONET or FDDI protocols.

In another embodiment, ring 104 is a dual ring, where one ring transmits packets in a clockwise direction and a second ring transmits packets in a counter-clockwise direction. In case of failure, the network reconfigures itself from a dual ring into a single logical working ring. Other systems, such as SONET, have also used dual ring configurations. SONET however, uses its dual rings to simultaneously send two versions of the bit stream: one version clockwise and the other counter-clockwise. While this strategy ensures reliability, it is also very wasteful of valuable bandwidth.

In contrast, an example of FSMP in accordance with the invention is explained with reference to Figs. 13a and 13b, which illustrates ring nodes 1...M. In Fig. 13a, each QoS Node on the ring monitors its incoming data streams from the dual links. The ring allows transmission in either direction (clockwise or counter-clockwise) in an embodiment of the invention for both robustness and to allow the shortest path to be chosen for communication between any two QoS Nodes, which helps enable the minimum rates of the SLAs to be met. Still, unlike SONET, only one version of the packet is sent. But if, for instance, the incoming stream to node M stops on the link from node M-1, as shown in Fig. 13b, then QoS Node M sends a message to QoS Node 1. QoS Node 1 confirms reception of the message to QoS Node M. QoS Node 1 then sends a message to QoS Node 2, which confirms receipt of the message, and the process continues. When QoS Node M-1 sends a message to QoS Node M, QoS Node M will not receive the message and, hence, QoS Node M-1 will not receive a confirming message.

When QoS Node M does not confirm the message, then failure of the links between QoS Node M-1 and QoS Node M is confirmed. The QoS Nodes then



- 23 -

reconfigure the rings as shown in Fig. 13b, such that a single ring is formed using the dual links. The QoS Nodes also initiate a network status update that triggers an alarm for the network bandwidth manager to re-run its calculations to determine whether the reconfiguration has resulted in any bandwidth reservations being violated (i.e., the question is asked of whether the network can still support the rate requirements of all the SLAs).

#### Time Stamp

As is known in the art, certain protocols, such as the Transmission Control Protocol (TCP), penalize connections that face long delays: the connections with short delays are awarded most of the link bandwidth. To avoid such penalties, some embodiments of the invention attach a time stamp to a packet as it enters a QoS Node from a packet switch. Once the packet has arrived at the QoS Node immediately prior to the destination packet switch, the packet goes through a playback buffer to ensure that the packet leaves T seconds after it entered the first QoS Node. In embodiments implementing this scheme, the QoS Nodes keep their clocks synchronized by using a standard clock synchronization method that will be known to those of skill in the art. In this manner, all connections are designated a minimum delay, preventing speedy connections from usurping excessive bandwidth.

\* \* \*

A system and method has now been described that allows efficient operations of a communications network that includes bandwidth guarantees. Some embodiments of the invention further provide delay guarantees as well as regulate data flow and provide network reliability. A system in accordance with the invention is not only high performance, but also economical, simple, and flexible, while remaining compatible with much of the hardware and software already in place, particularly hardware and software for routers and ethernet interfaces. In essence, the SLAs for a system and method in accordance with the invention can

- 24 -

be equated to virtual leased lines. Further, because the network management system enables straightforward provisioning and monitoring of SLAs, an embodiment of the invention may be particularly useful in a metropolitan area network (MAN).

5           It should be understood that the particular embodiments described above are only illustrative of the principles of the present invention, and various modifications could be made by those skilled in the art without departing from the scope and spirit of the invention. Thus, the scope of the present invention is limited only by the claims that follow.

10

- 25 -

CLAIMS

What is claimed is:

1. A method of data communications in a network including a plurality of  
5 packet switches and a plurality of quality of service (QoS) nodes, comprising the  
steps of:  
receiving, by a QoS node, a plurality of data packets each including  
classification information;  
classifying, by said QoS node, each of said data packets with one of a  
10 plurality of service level agreements (SLAs) corresponding to said classification  
information for the respective packet;  
without reformatting said data packets, statistically multiplexing, by said  
QoS node, said data packets for transmission in a manner that results in  
transmission of data packets for each SLA at at least a minimum data rate that  
15 corresponds to said respective SLA.
2. The method of claim 1, wherein  
said step of classifying further includes placing each packet into a queue  
corresponding to said respective one of said plurality of SLAs.  
20
3. The method of claim 2, wherein said step of statistically multiplexing  
includes multiplexing data packets from each SLA queue in accordance with a  
deficit round robin (DRR) method.
- 25 4. The method of claim 2, wherein said step of statistically multiplexing  
includes multiplexing data packets from each SLA queue in accordance with a a  
deficit golden ratio method.

- 26 -

5. The method of claim 1, further including the steps of  
assigning an integer value to each SLA;  
said step of statistically multiplexing includes, for each respective data  
packet, if a number of data packets in a data packet transmit queue classified with  
the SLA corresponding to the respective data packet is less than the integer value,  
5 adding the respective data packet to the end of the queue, but if the number of data  
packets for the respective SLA is greater than or equal to said integer value, then  
discarding said data packet.
- 10 6. The method of claim 1, further including the steps of  
assigning an integer value to each SLA;  
said step of statistically multiplexing includes, for each respective data  
packet, if a number of data bits in a data packet transmit queue classified with the  
SLA corresponding to the respective data packet is less than the integer value,  
15 adding the respective data packet to the end of the queue, but if the number of data  
bits for the respective SLA is greater than or equal to said integer value, then  
discarding said data packet.
7. The method of claim 1, further including:  
20 monitoring each SLA for congestion, and if a congested condition is found  
for one of said SLAs, reducing the data rate for transmitting packets for that one  
SLA.
8. The method of claim 7, wherein said data rate is reduced to said minimum  
25 data rate.
9. The method of claim 7, wherein said data rate is reduced to zero.
10. The method of claim 1, wherein said data packets are ethernet packets.

- 27 -

11. A method of data communications in a network including a plurality of packet switches and a plurality of quality of service (QoS) nodes, comprising the steps of:
- receiving, by a QoS node, a plurality of data packets from at least one packet switch, wherein each data packet includes classification information;
- 5 classifying, by said QoS node, each of said data packets with one of a plurality of service level agreements (SLAs) corresponding to said classification information for the respective packet;
- adding, by said QoS node, each packet to a respective one of a plurality of SLA queues corresponding to the respective SLA with which the data packet is classified;
- 10 statistically multiplexing, by said QoS node, the data packets from each SLA queue so that for each respective SLA data packets are transmitted at at least a minimum data rate that corresponds to said respective SLA.
- 15
12. The method of claim 11, wherein said step of statistically multiplexing includes multiplexing data packets from each SLA queue in accordance with a deficit golden ratio method.
- 20
13. The method of claim 11, wherein said step of statistically multiplexing includes multiplexing data packets from each SLA queue in accordance with a deficit round robin method.
- 25
14. The method of claim 12, wherein said classification information includes a source identifier and a destination identifier.
15. The method of claim 14, wherein said classification information further includes additional information.

- 28 -

16. The method of claim 11, wherein the data packets are in an ethernet format.
17. The method of claim 14, further including the step of:  
controlling network congestion by reducing the rate of transmission from  
5 a selected SLA queue in a selected network node.
18. A method of data communications in a network including a plurality of  
packet switches and a plurality of quality of service (QoS) nodes, comprising the  
steps of:  
10 receiving, by a QoS node, a plurality of data packets from at least one  
packet switch, wherein each data packet includes classification information;  
assigning a threshold value to each service level agreement (SLA) in a  
plurality of SLAs;  
classifying each of said data packets with one of said SLAs corresponding  
15 to said classification information for the respective packet;  
adding a respective data packet to a transmit queue on a first-come, first-  
served basis if a number of data units in said transmit queue classified with the SLA  
for the respective data packet is less than the threshold value, but if the number of  
data units for the respective SLA is greater than or equal to said threshold value,  
20 then discarding said respective data packet; and  
transmitting said data packets from said transmit queue such that for each  
quality-of-service agreement said data packets are transmitted at at least a minimum  
data rate that corresponds to said respective quality-of-service agreement.
- 25 19. The method of claim 18, wherein said classification information includes a  
source identifier and a destination identifier.
20. The method of claim 19, wherein said classification information further  
includes additional information.

- 29 -

21. The method of claim 18, wherein said data units are data packets.
22. The method of claim 18, wherein said data units are data bits.
- 5 23. The method of claim 18, wherein the data packets are in an ethernet format.
24. The method of claim 18, further including the step of:  
controlling network congestion by reducing the rate of transmission for an  
SLA in a selected network node.
- 10 25. A network, comprising:  
a plurality of packet switches;  
a plurality of QoS Nodes, including a first set of QoS Nodes linked to form  
a ring and a second set of QoS Nodes, where each QoS Node in said second set is  
15 linked to a respective QoS Node from said first set thereby forming a ring-star  
topology with said first and second sets of QoS Nodes, and wherein each respective  
packet switch is linked to a respective QoS Node so that at least some of said QoS  
Nodes receive data packets from said packet switches;  
wherein each QoS Node includes:  
20 an input for receiving said data packets;  
a service level agreement (SLA) packet classifier in communication  
with said input;  
a statistical multiplexing scheduler; and  
a transmit queue in communication with said scheduler and said  
25 classifier; and  
an output in communication with said transmit queue and for  
carrying data packets at a minimum data rate for each of a plurality of  
SLAs.

- 30 -

26. The network of claim 25, wherein:  
each QoS node includes a plurality of SLA queues, where each queue corresponds to an SLA; and  
said statistical multiplexing scheduler is a deficit golden ratio scheduler in  
5 communication with each of said SLA queues.
27. The network of claim 25, wherein:  
said statistical multiplexing scheduler is an SLA early discard scheduler.
- 10 28. The network of claim 25 wherein said first set of QoS nodes are linked to form a dual ring, and wherein each QoS node in said first set is capable of cooperating with other QoS nodes to reconfigure the dual ring into a single ring upon failure of a link.
- 15 29. A quality of service (QoS) node for use in a communication network, comprising:  
an input for receiving a plurality of data packets each including classification information;  
means for classifying each of said data packets with one of a plurality of  
20 service level agreements (SLAs) corresponding to said classification information for the respective packet;  
means for statistically multiplexing data packets for transmission from each of said SLAs, without reformatting said packets, such that data packets corresponding to each SLA are transmitted at at least a minimum data rate  
25 corresponding to the respective SLA.
30. The QoS node of claim 29, wherein:  
said means for classifying is further for placing each packet into a queue corresponding to said respective one of said plurality of SLAs.



- 31 -

31. The QoS node of claim 30, wherein:  
said means for statistically multiplexing includes multiplexing data packets from each SLA queue in accordance with a deficit round robin (DRR) method.
- 5 32. The QoS node of claim 30, wherein:  
said means for statistically multiplexing includes multiplexing data packets from each SLA queue in accordance with a deficit golden ratio method.
- 10 33. The QoS node of claim 29, wherein:  
said means for statistically multiplexing is further, for each respective data packet, if a number of data packets in a data packet transmit queue classified with the SLA corresponding to the respective data packet is less than an assigned value, for adding the respective data packet to the end of the queue, but if the number of data packets for the respective SLA is greater than or equal to said assigned value,  
15 then for discarding said data packet.
34. The QoS node of claim 29, wherein:  
said means for statistically multiplexing is further, for each respective data packet, if a number of data bits in a data packet transmit queue classified with the  
20 SLA corresponding to the respective data packet is less than an assigned value, for adding the respective data packet to the end of the queue, but if the number of data bits for the respective SLA is greater than or equal to said assigned value, then for discarding said data packet.
- 25 35. The QoS node of claim 29, further including:  
means for monitoring each SLA for congestion, and if a congested condition is found for one of said SLAs, for reducing the data rate for transmitting packets for that one SLA.

- 32 -

36. The method of claim 35, wherein said data rate is reduced to said minimum data rate.

37. The method of claim 35, wherein said data rate is reduced to zero.

5

38. The method of claim 29, wherein said data packets are ethernet packets.

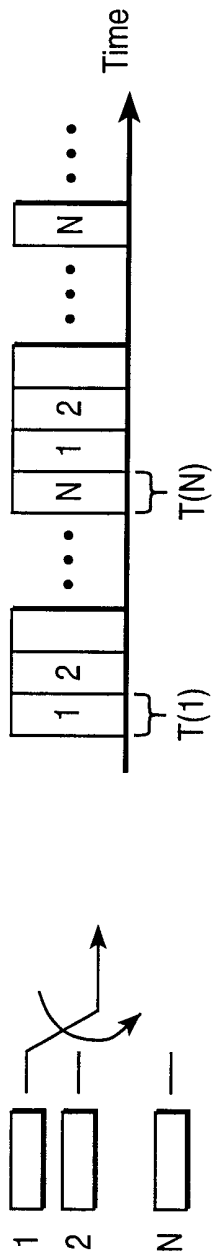

Time-Division Multiplexing (TDM)

FIG. 1

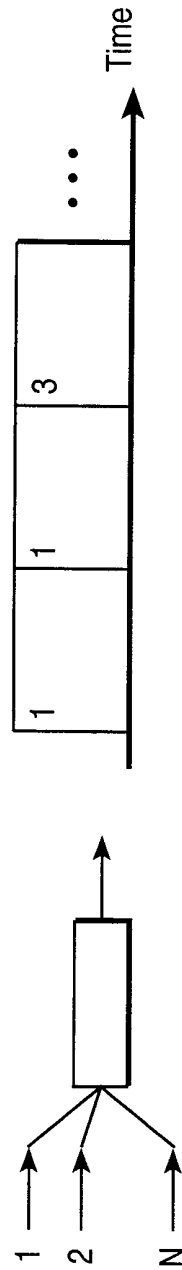

Statistical Multiplexing — First Come, First Served

FIG. 2

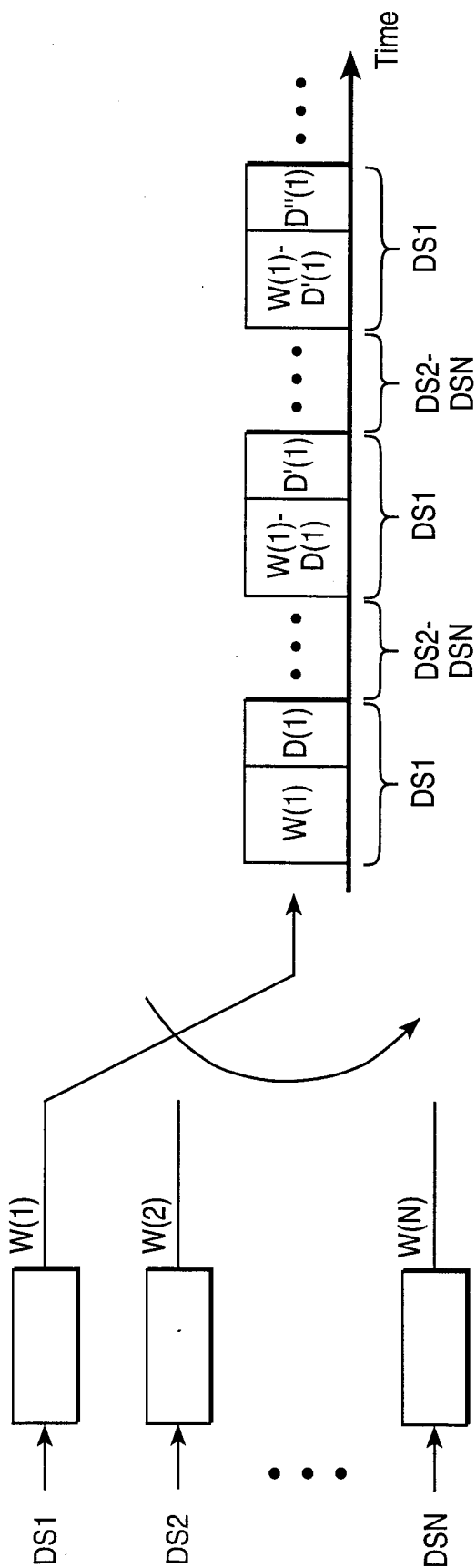

FIG. 3

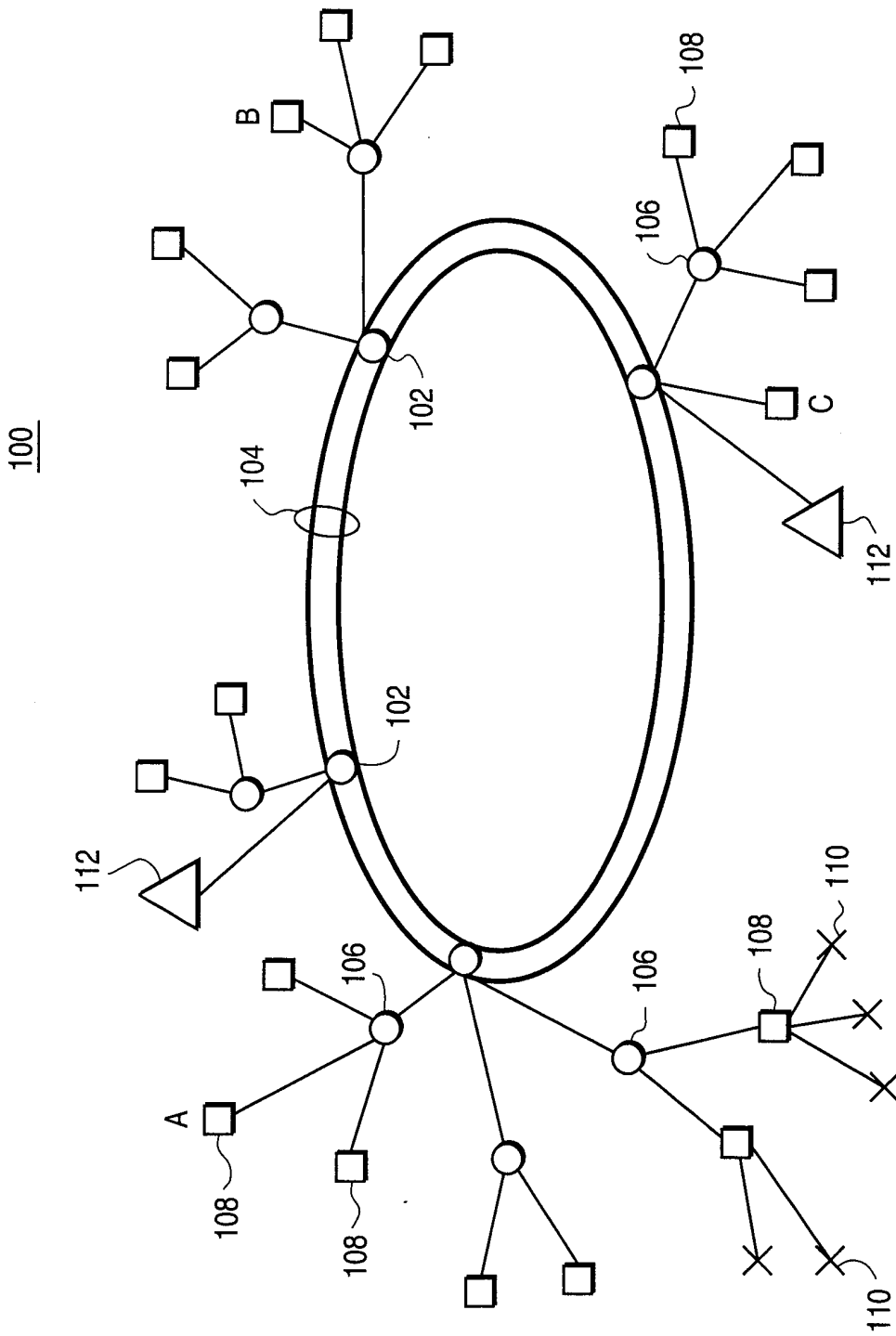

FIG. 4

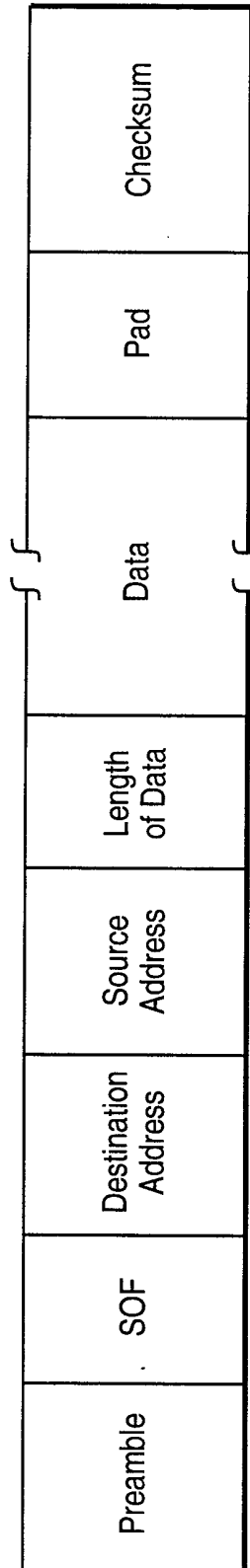
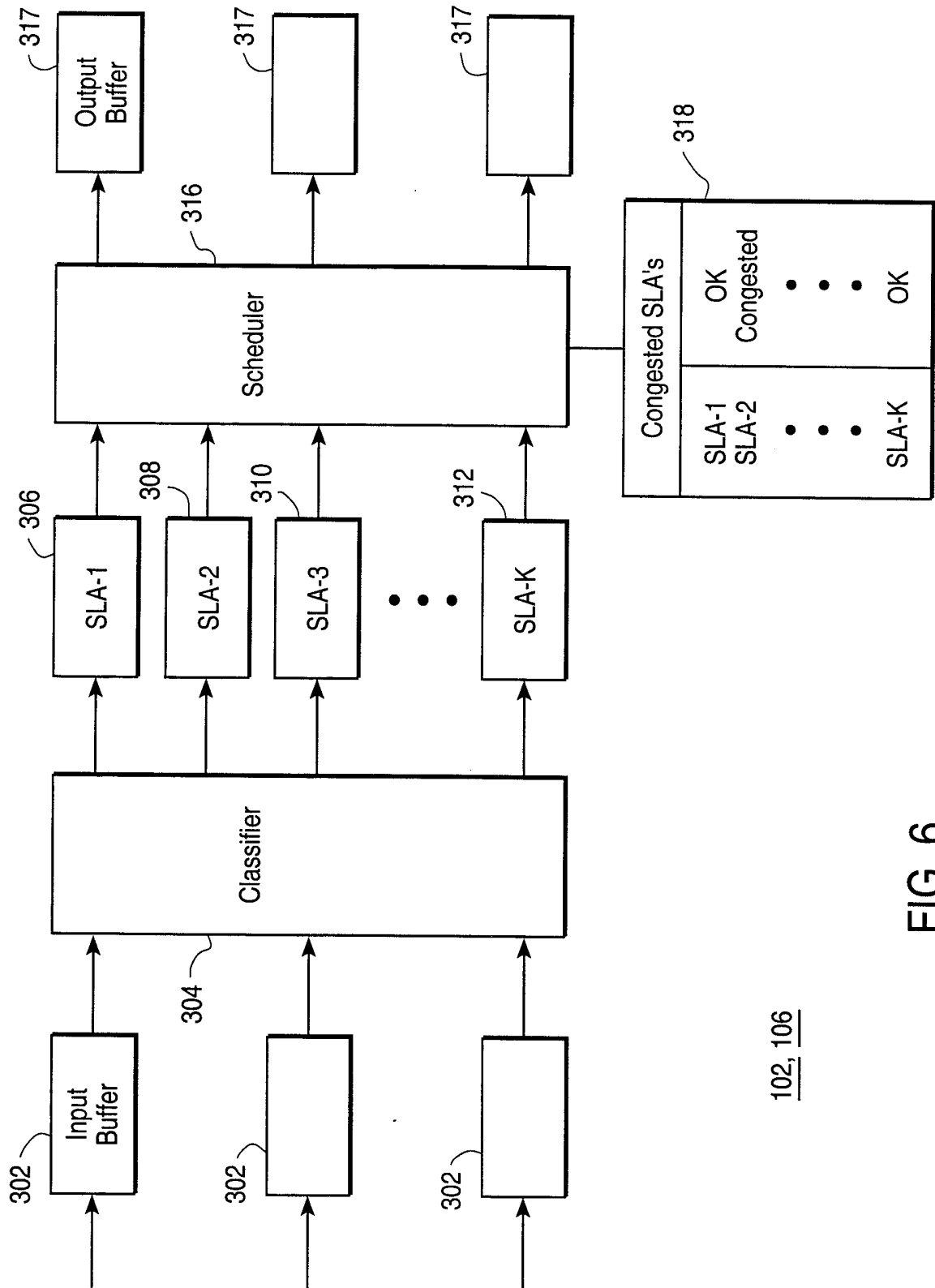

FIG. 5



102, 106

FIG. 6

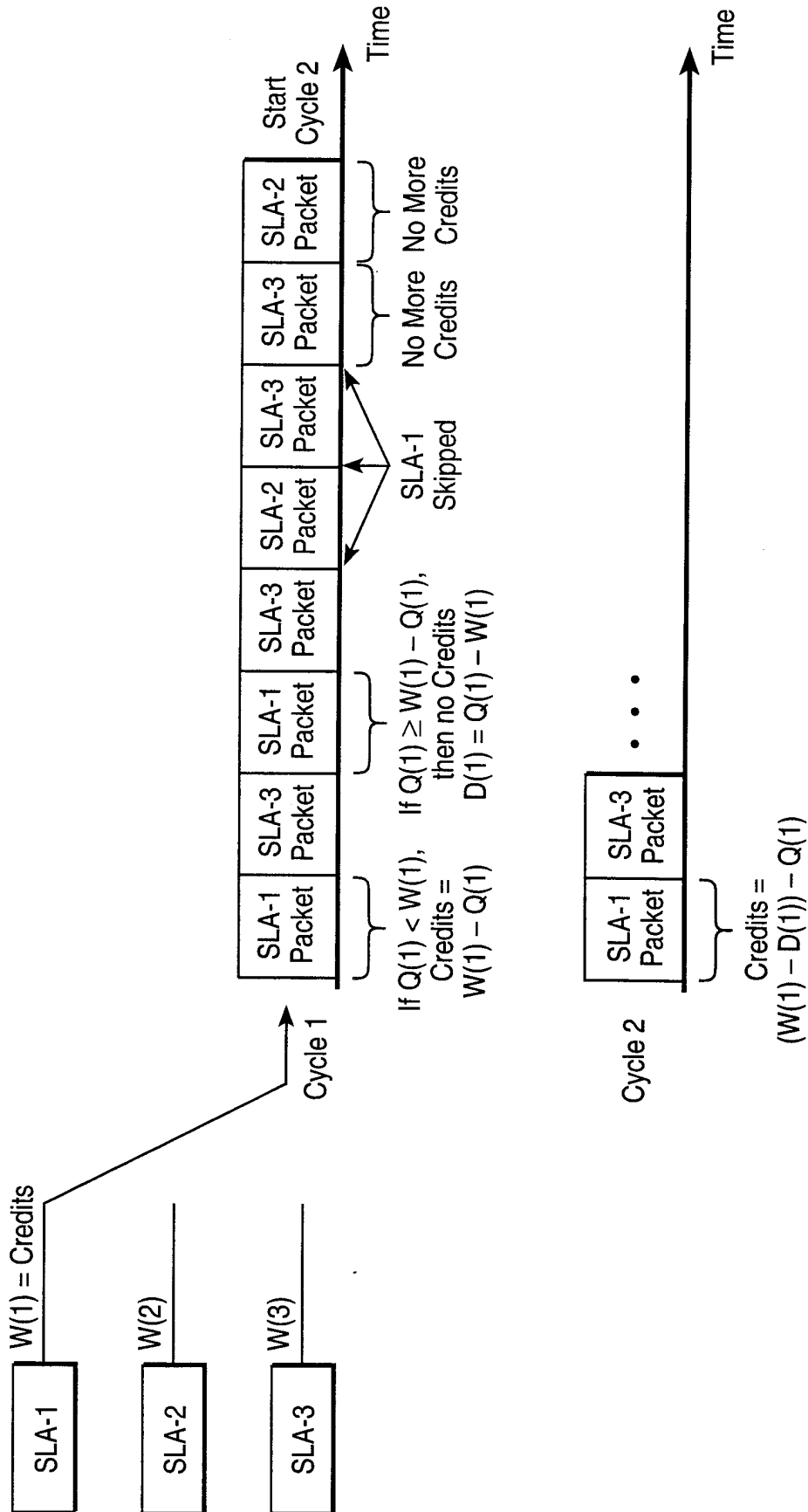

FIG. 7



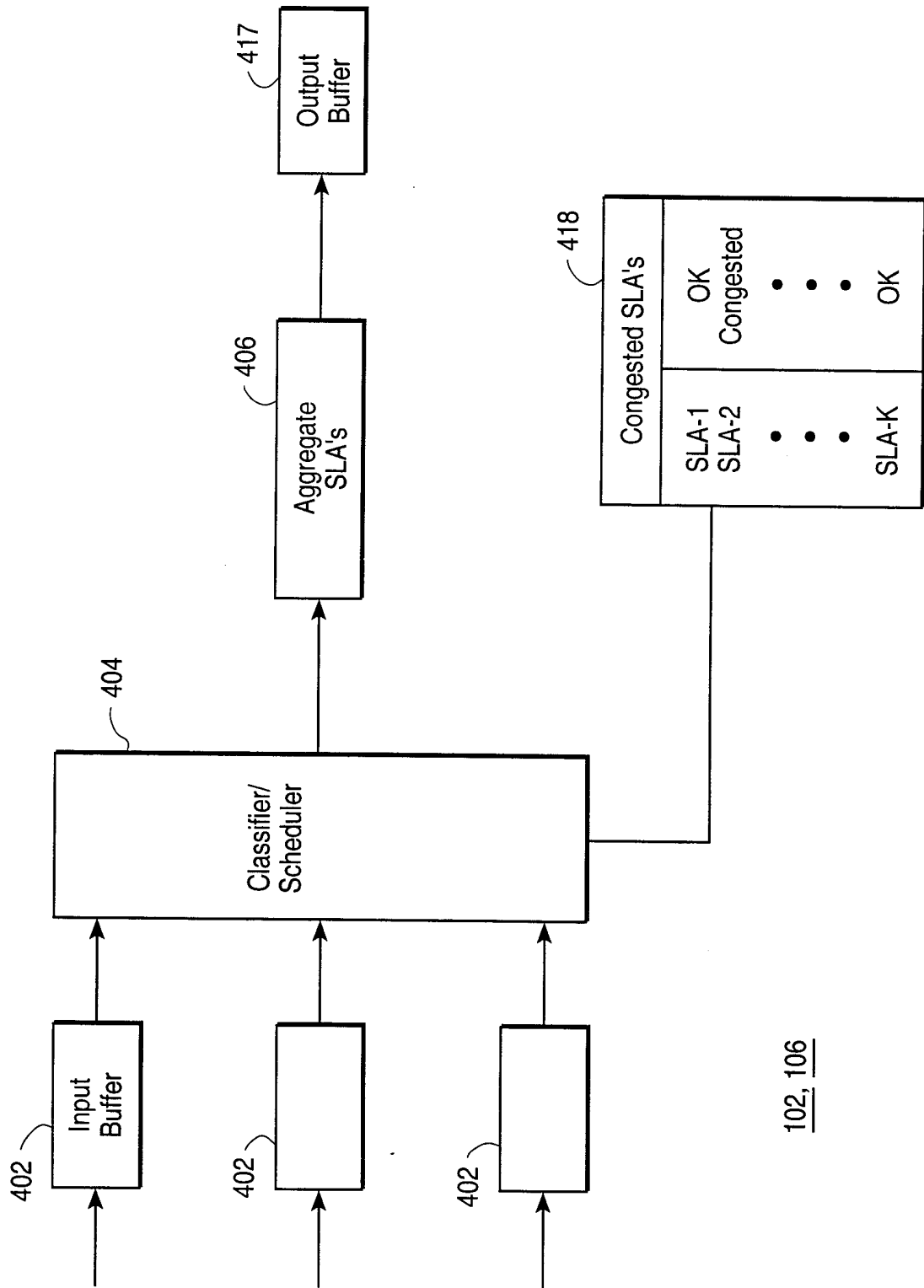

FIG. 8

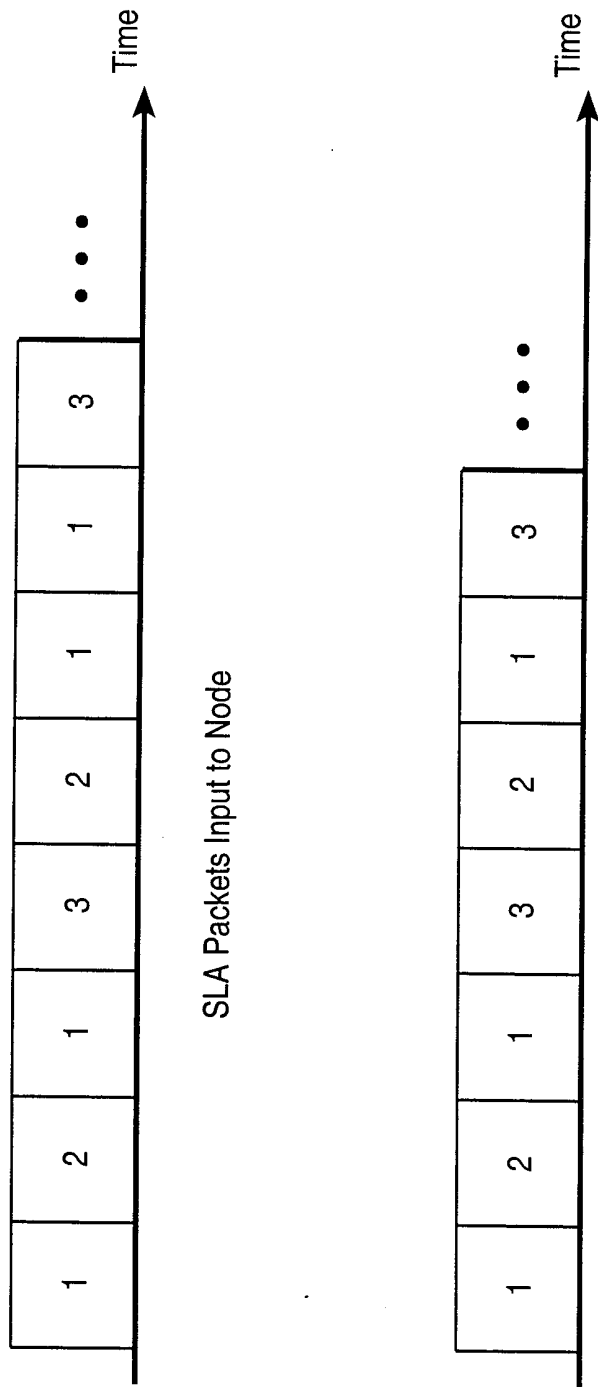

FIG. 9

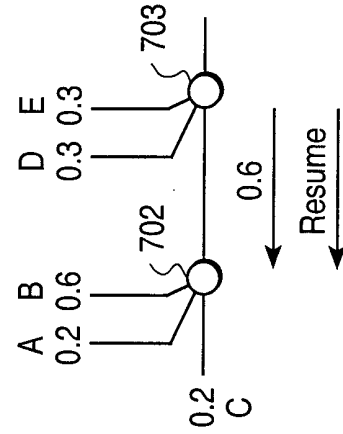

FIG. 10

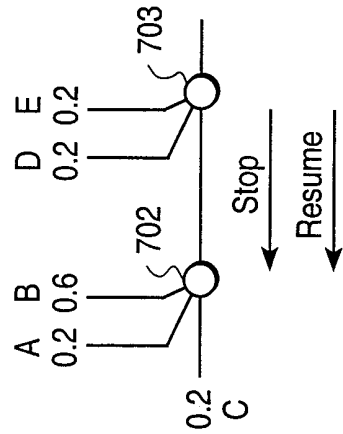

FIG. 11

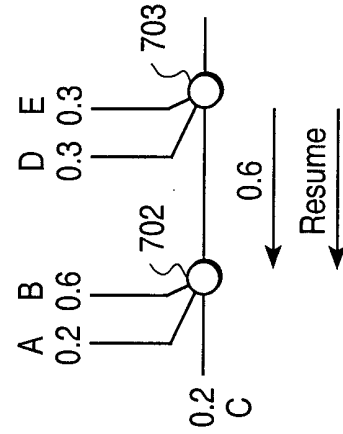

FIG. 12

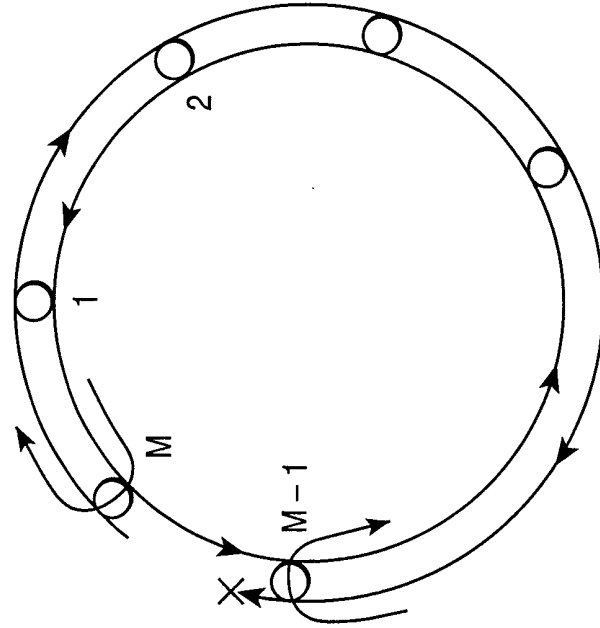

FIG. 13b

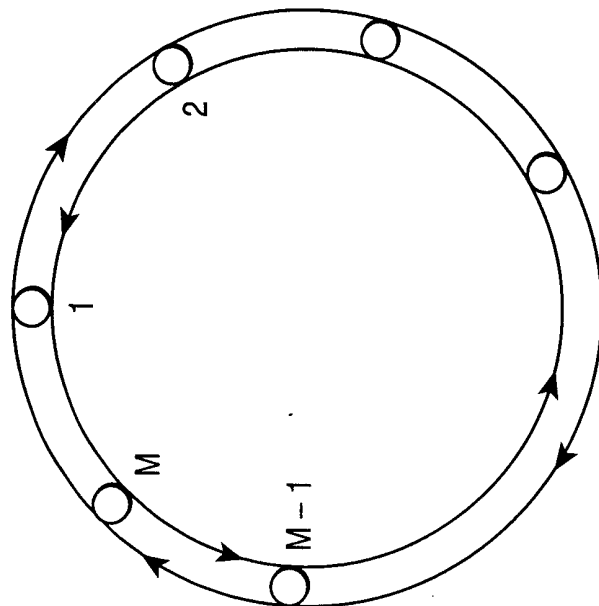

FIG. 13a

# INTERNATIONAL SEARCH REPORT

International Application No

PCT/US 99/22943

**A. CLASSIFICATION OF SUBJECT MATTER**  
 IPC 7 H04L12/56 H04L29/06

According to International Patent Classification (IPC) or to both national classification and IPC

**B. FIELDS SEARCHED**

Minimum documentation searched (classification system followed by classification symbols)

IPC 7 H04L

Documentation searched other than minimum documentation to the extent that such documents are included in the fields searched

Electronic data base consulted during the international search (name of data base and, where practical, search terms used)

**C. DOCUMENTS CONSIDERED TO BE RELEVANT**

Category °	Citation of document, with indication, where appropriate, of the relevant passages	Relevant to claim No.
X	US 5 359 592 A (GOMEZ RAFAEL ET AL) 25 October 1994 (1994-10-25)  column 1, line 15 -column 3, line 19 column 4, line 26 - line 33 column 8, line 51 -column 10, line 66 column 14, line 8 -column 15, line 10 column 16, line 41 - line 49 column 17, line 49 -column 18, line 28; figure 15	1, 2, 5-11, 16-18, 21-24, 29, 30, 33-38
A	---  -/--	3, 4, 12-15, 19, 20, 25, 31, 32

Further documents are listed in the continuation of box C.

Patent family members are listed in annex.

° Special categories of cited documents :

- "A" document defining the general state of the art which is not considered to be of particular relevance
- "E" earlier document but published on or after the international filing date
- "L" document which may throw doubts on priority claim(s) or which is cited to establish the publication date of another citation or other special reason (as specified)
- "O" document referring to an oral disclosure, use, exhibition or other means
- "P" document published prior to the international filing date but later than the priority date claimed

- "T" later document published after the international filing date or priority date and not in conflict with the application but cited to understand the principle or theory underlying the invention
- "X" document of particular relevance; the claimed invention cannot be considered novel or cannot be considered to involve an inventive step when the document is taken alone
- "Y" document of particular relevance; the claimed invention cannot be considered to involve an inventive step when the document is combined with one or more other such documents, such combination being obvious to a person skilled in the art.
- "&" document member of the same patent family

Date of the actual completion of the international search

18 February 2000

Date of mailing of the international search report

29/02/2000

Name and mailing address of the ISA

European Patent Office, P.B. 5818 Patentlaan 2  
 NL - 2280 HV Rijswijk  
 Tel. (+31-70) 340-2040, Tx. 31 651 epo nl,  
 Fax: (+31-70) 340-3016

Authorized officer

Brichau, G

# INTERNATIONAL SEARCH REPORT

International Application No

PCT/US 99/22943

**C.(Continuation) DOCUMENTS CONSIDERED TO BE RELEVANT**

Category	Citation of document, with indication, where appropriate, of the relevant passages	Relevant to claim No.
X	WO 98 45976 A (ASCEND COMMUNICATIONS INC) 15 October 1998 (1998-10-15) page 1, line 16 - line 35 page 2, line 35 -page 3, line 16 page 6, line 29 -page 7, line 18 page 8, line 6 - line 18 ---	1-3,11, 13,29-31
A	US 5 812 545 A (THALLER FRANZ ET AL) 22 September 1998 (1998-09-22) column 5, line 5 -column 6, line 11 column 10, line 3 - line 62 column 11, line 34 -column 12, line 41 column 16, line 47 -column 17, line 9 -----	1,11,18, 25,29

# INTERNATIONAL SEARCH REPORT

Information on patent family members

Int. l. Application No

PCT/US 99/22943

Patent document cited in search report	Publication date	Patent family member(s)	Publication date
US 5359592    A	25-10-1994	AU 7199494 A	17-01-1995
		EP 0705526 A	10-04-1996
		JP 8511927 T	10-12-1996
		WO 9501076 A	05-01-1995
WO 9845976    A	15-10-1998	AU 6788598 A	30-10-1998
		AU 6873198 A	30-10-1998
		EP 0972378 A	19-01-2000
		EP 0972379 A	19-01-2000
		US 5905730 A	18-05-1999
		US 5850399 A	15-12-1998
		WO 9845990 A	15-10-1998
US 5812545    A	22-09-1998	AU 1823597 A	01-08-1997
		EP 0875103 A	04-11-1998
		WO 9725787 A	17-07-1997