



US00D422546S

United States Patent [19]

[11] Patent Number: **Des. 422,546**

Toyota

[45] Date of Patent: **** Apr. 11, 2000**

[54] **FRONT PORTION OF A MOTOR VEHICLE**

D. 413,552 9/1999 Sims et al. D12/92

[75] Inventor: **Tsuyoshi Toyoda**, Aki-gun, Japan

Primary Examiner—Melody N. Brown
Attorney, Agent, or Firm—Sidley & Austin; Hugh A. Abrams

[73] Assignee: **Mazda Motor Corporation**,
Hiroshima-ken, Japan

[57] CLAIM

[**] Term: **14 Years**

The ornamental design for a front portion of a motor vehicle, as shown and described.

[21] Appl. No.: **29/094,205**

DESCRIPTION

[22] Filed: **Sep. 28, 1998**

FIG. 1 is a perspective view of a first front portion of a motor vehicle;
FIG. 2 is a front view of the first front portion;
FIG. 3 is a rear view of the motor vehicle;
FIG. 4 is a right side view of the first front portion, the opposite side being a mirror image of the side shown herein; and,
FIG. 5 is a top view of the first front portion.

[51] **LOC (6) Cl.** **12-16**

[52] **U.S. Cl.** **D12/196**

[58] **Field of Search** D12/196, 90-92;
296/185

The portion of the motor vehicle shown in broken lines is for illustrative purpose only and forms no part of the claimed design.

[56] References Cited

U.S. PATENT DOCUMENTS

- D. 373,331 9/1996 Ohkura et al. D12/91
- D. 402,232 12/1998 Hayachi et al. D12/92
- D. 407,349 3/1999 Murakami et al. D12/91
- D. 407,350 3/1999 Crain D12/92

1 Claim, 4 Drawing Sheets

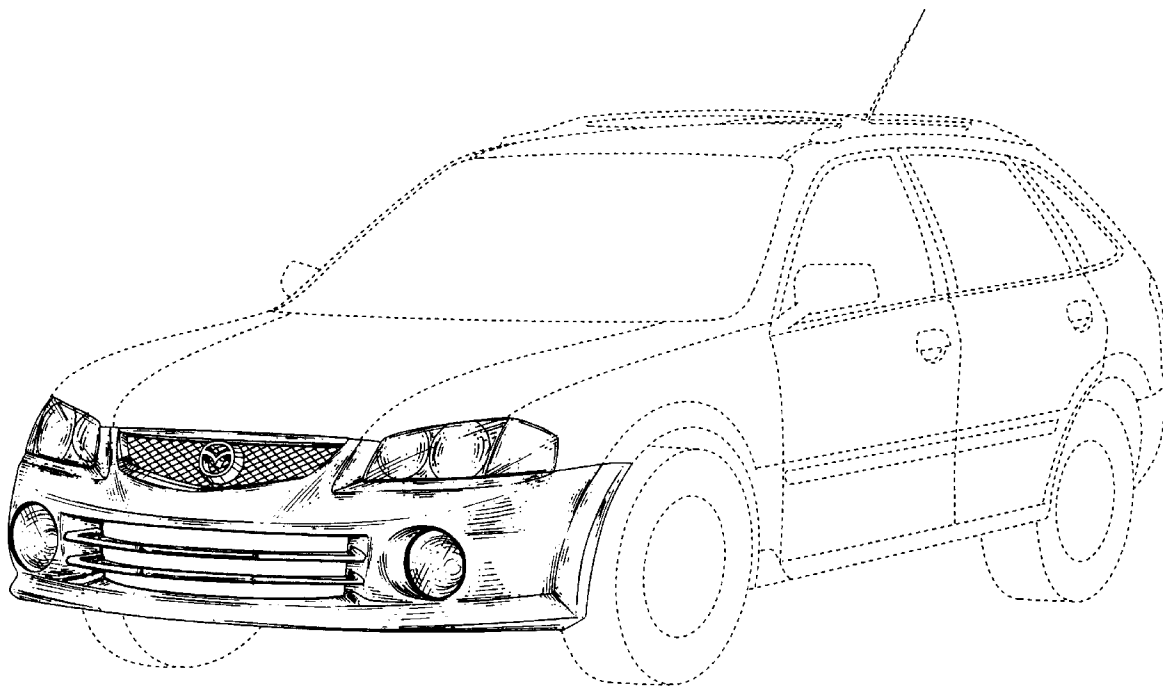

FIG. 1

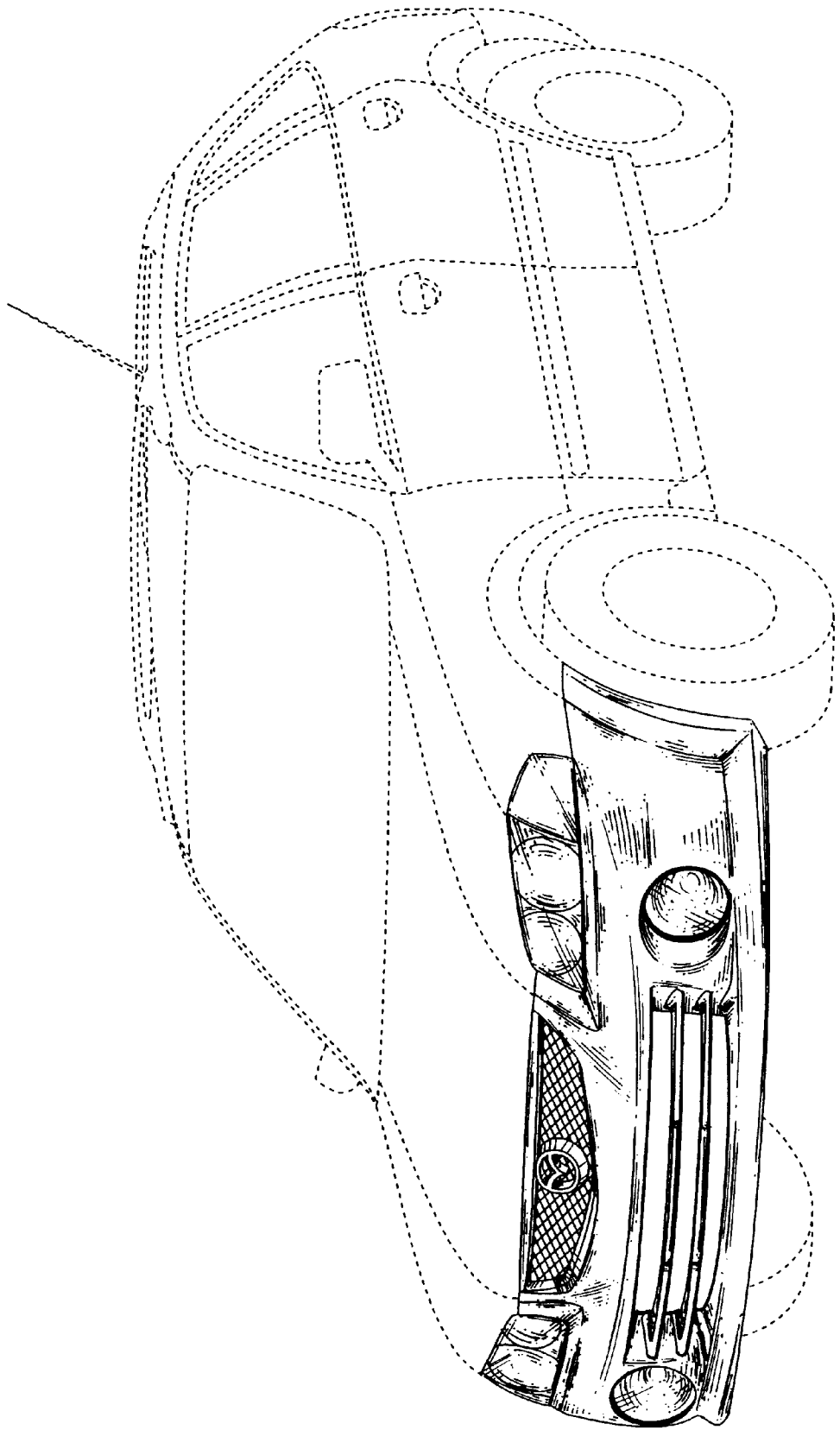

FIG. 2

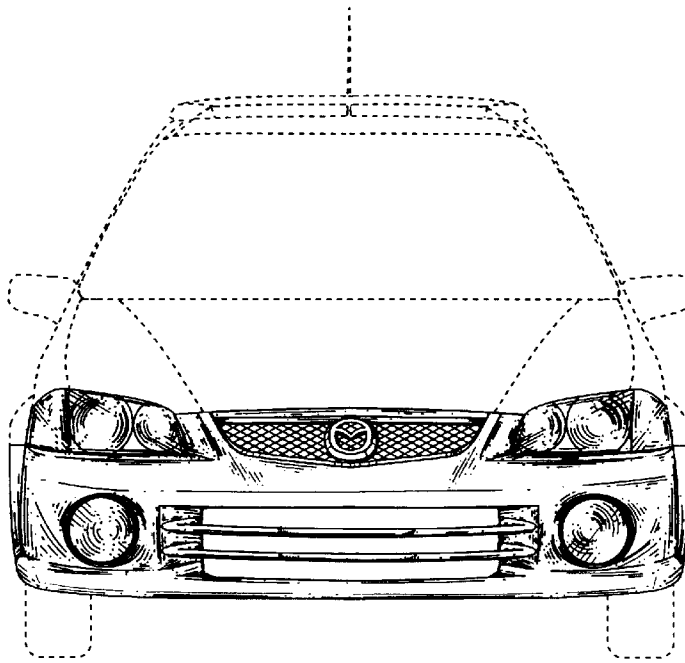

FIG. 3

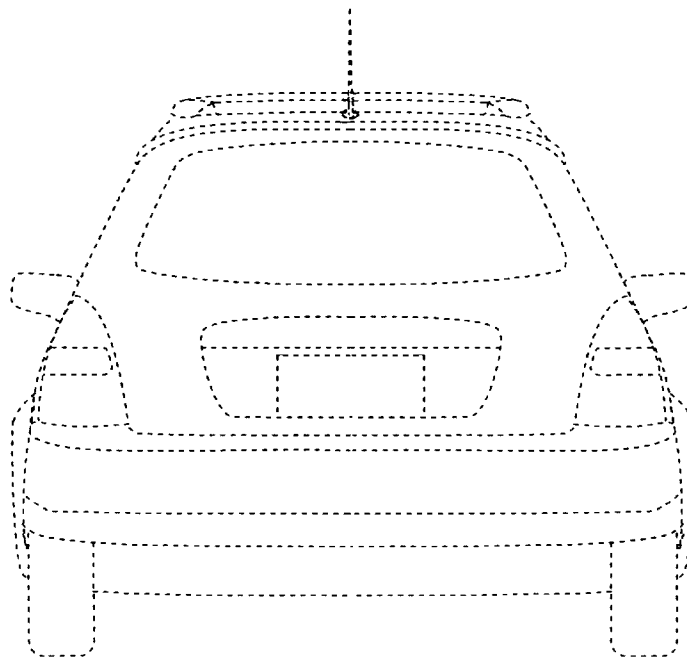

FIG. 5

