



US00D332239S

United States Patent [19]

[11] Patent Number: Des. 332,239

Hirata et al.

[45] Date of Patent: ** Jan. 5, 1993

[54] UTILITY VEHICLE

[75] Inventors: Makizo Hirata, Kakogawa; Fumio Mizuta; Teruyasu Tamashima, both of Akashi, all of Japan

[73] Assignee: Kawasaki Jukogyo Kabushiki Kaisha, Japan

[**] Term: 14 Years

[21] Appl. No.: 613,368

[22] Filed: Nov. 15, 1990

[52] U.S. Cl. D12/1; D12/14

[58] Field of Search D12/1, 14; 280/756; 180/22, 24.01, 24.11; 414/460

[56] References Cited

U.S. PATENT DOCUMENTS

D. 240,848	8/1976	Henderson et al.	D12/1
D. 269,077	5/1983	Horton	D12/1
D. 292,899	11/1987	Samuelson et al.	D12/16
D. 312,227	11/1990	Miyamoto et al.	D12/14
D. 315,325	3/1991	Legueu	D12/1
3,664,450	5/1972	Udden et al.	D12/1

4,153,262	5/1979	Diamond et al.	280/756
4,669,565	6/1987	Miki et al.	280/756
4,924,959	5/1990	Handa et al.	280/756
4,946,193	8/1990	Oka	D12/14
4,987,522	1/1991	Miyano et al.	280/756

FOREIGN PATENT DOCUMENTS

63-202579 12/1988 Japan .

Primary Examiner—Wallace R. Burke
Assistant Examiner—Melody Brown
Attorney, Agent, or Firm—Marshall, O'Toole, Gerstein, Murray & Bicknell

[57] CLAIM

The ornamental design for a utility vehicle, as shown.

DESCRIPTION

FIG. 1 is a perspective view of the top, front and one side of a utility vehicle showing our new design; FIG. 2 is a front elevational view thereof; FIG. 3 is a rear elevational view thereof; FIG. 4 is a left side elevational view thereof; FIG. 5 is a right side elevational view thereof; FIG. 6 is a bottom plan view thereof; and, FIG. 7 is a top plan view thereof.

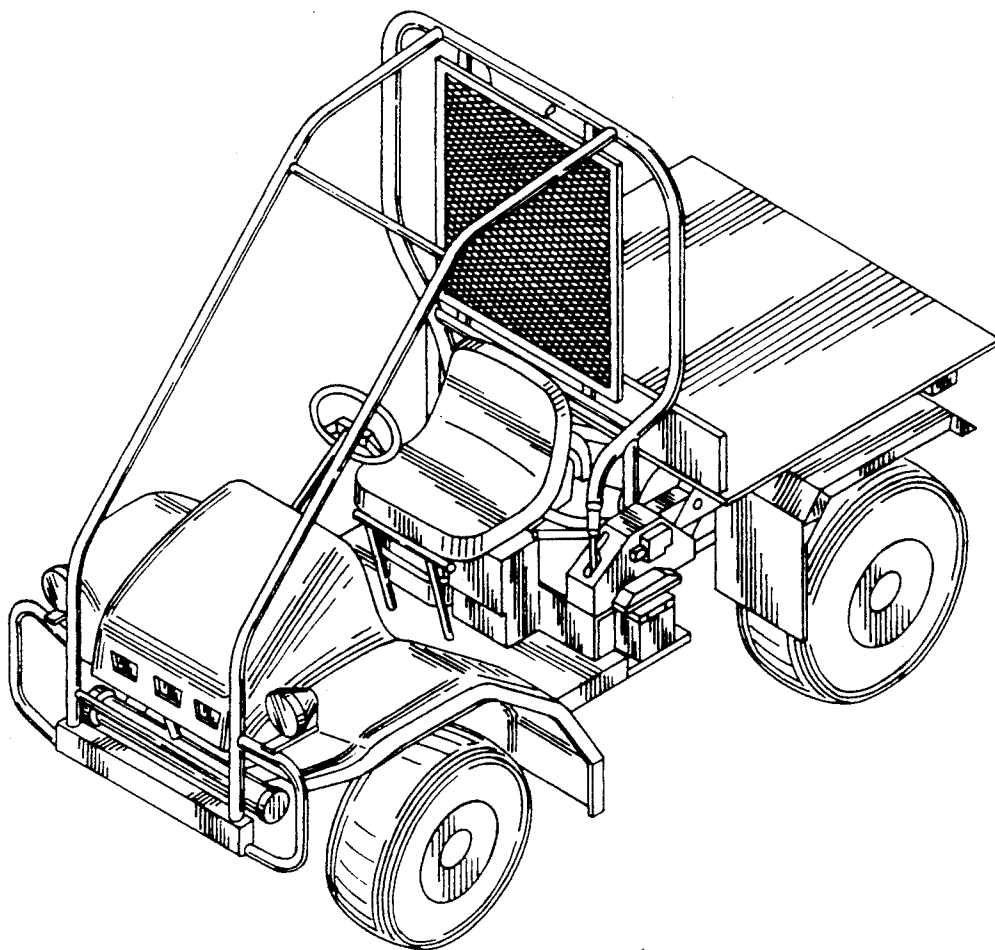

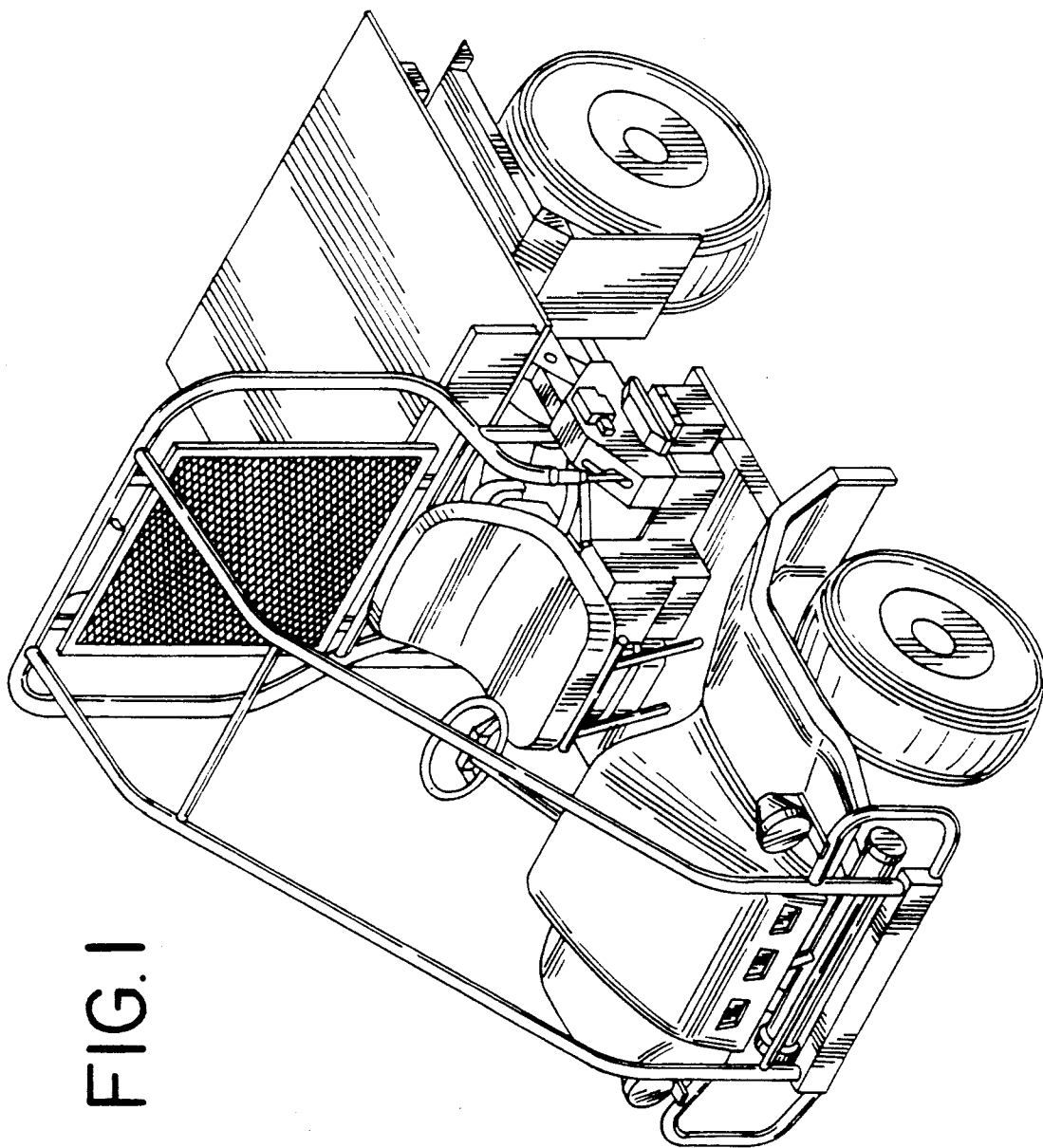

FIG. 1

FIG.3

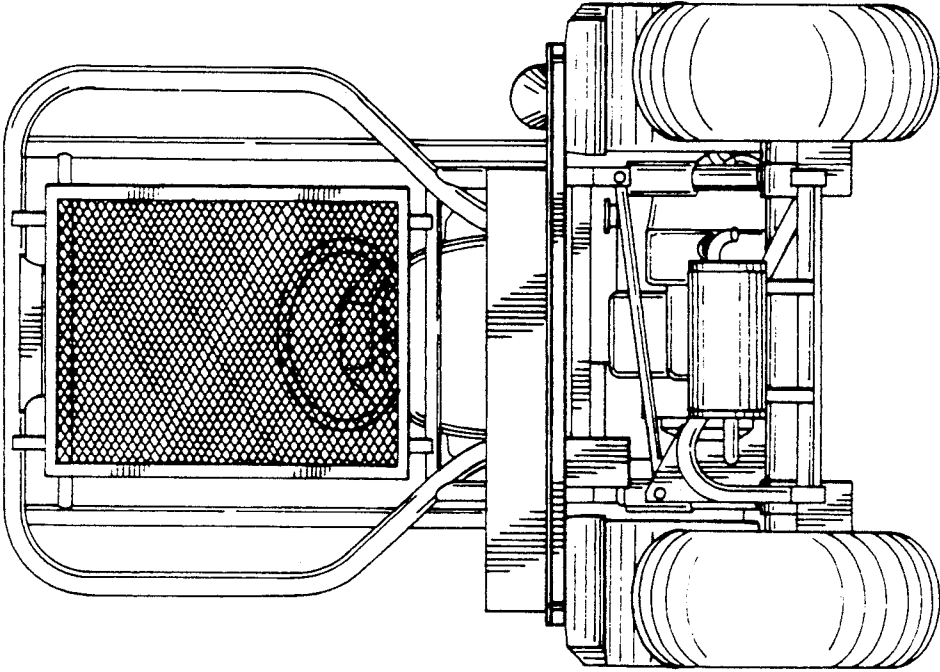
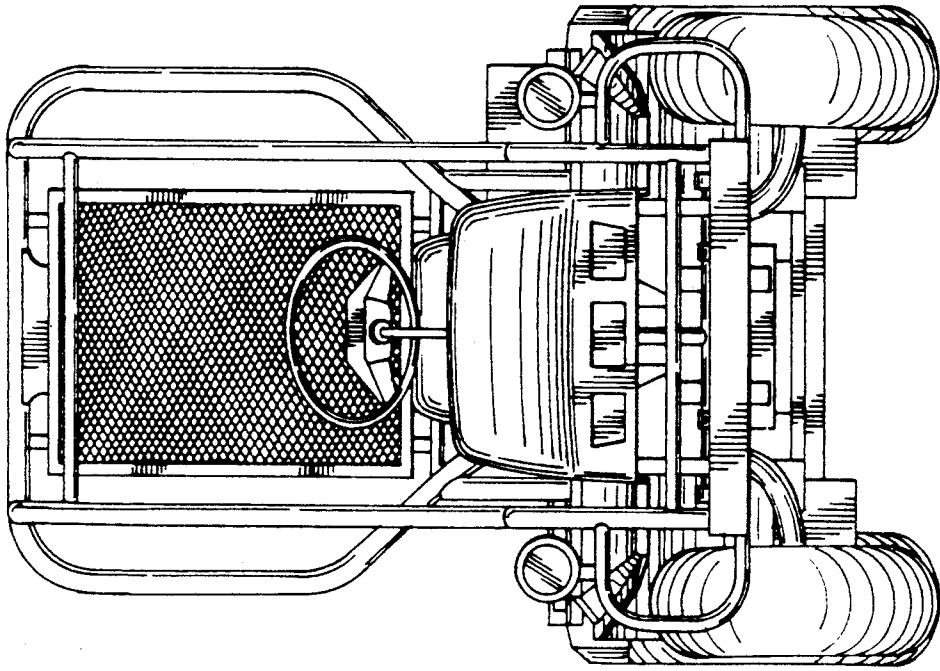

FIG.2



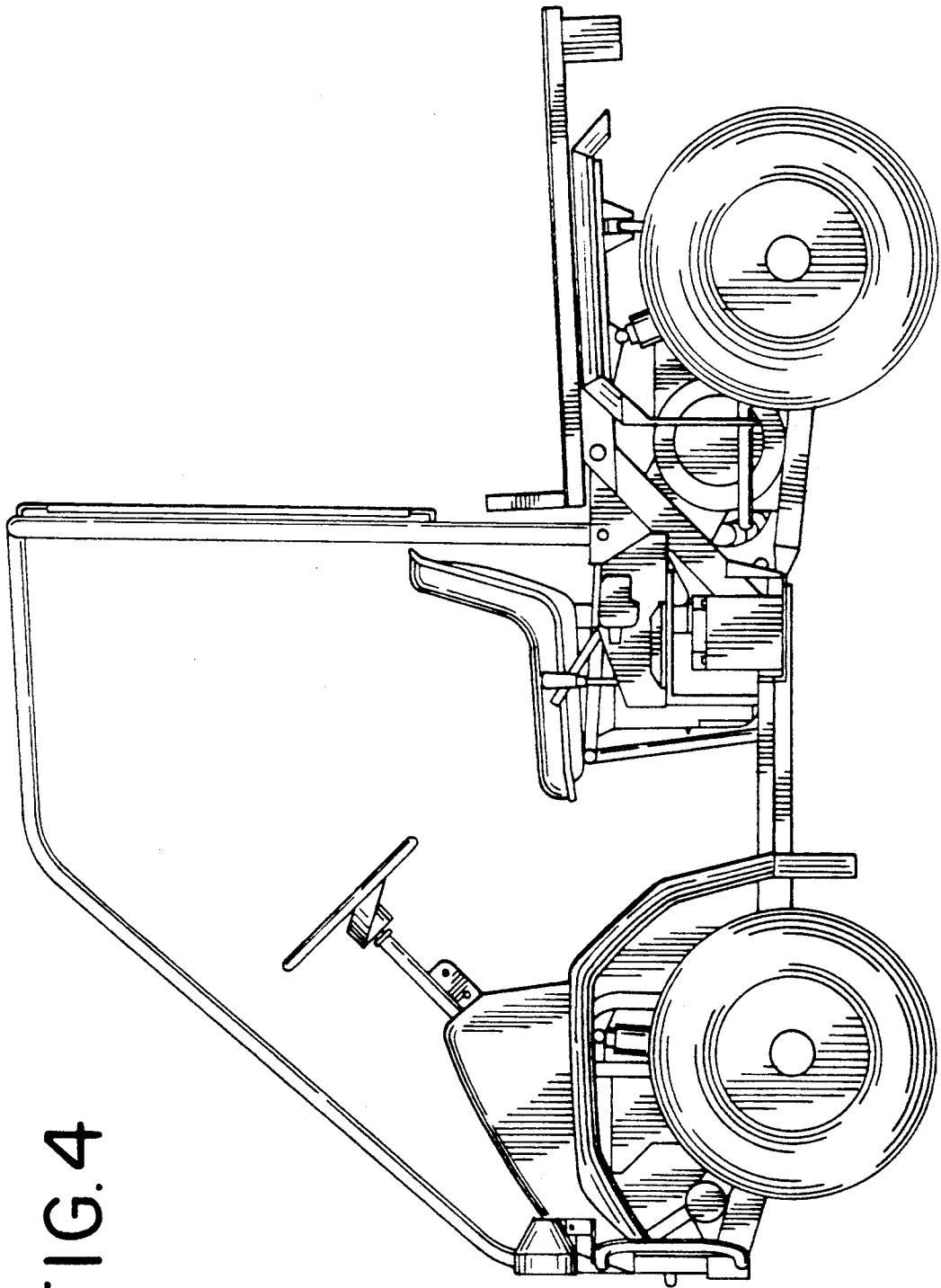

FIG.4

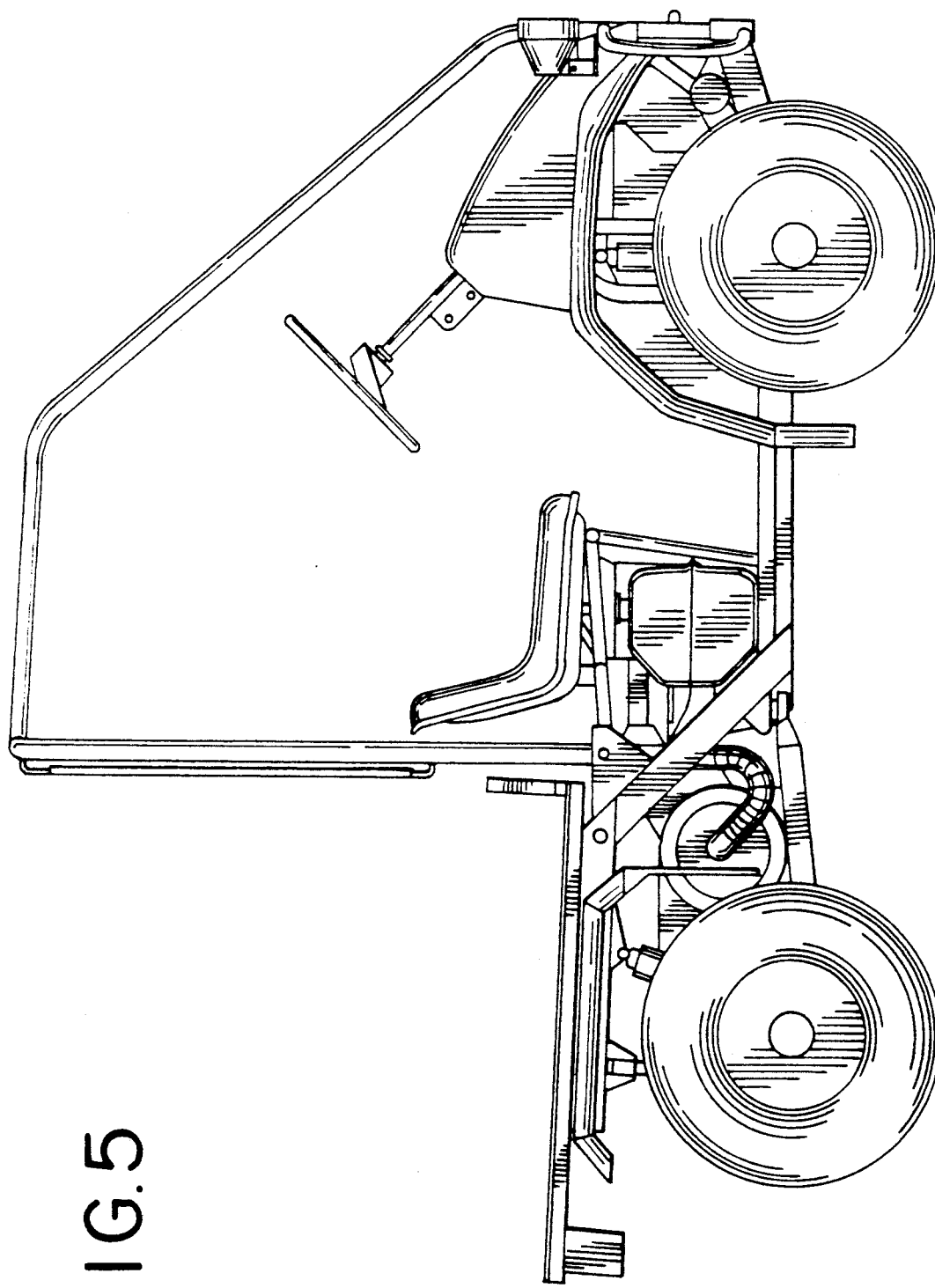

FIG.5

FIG. 6

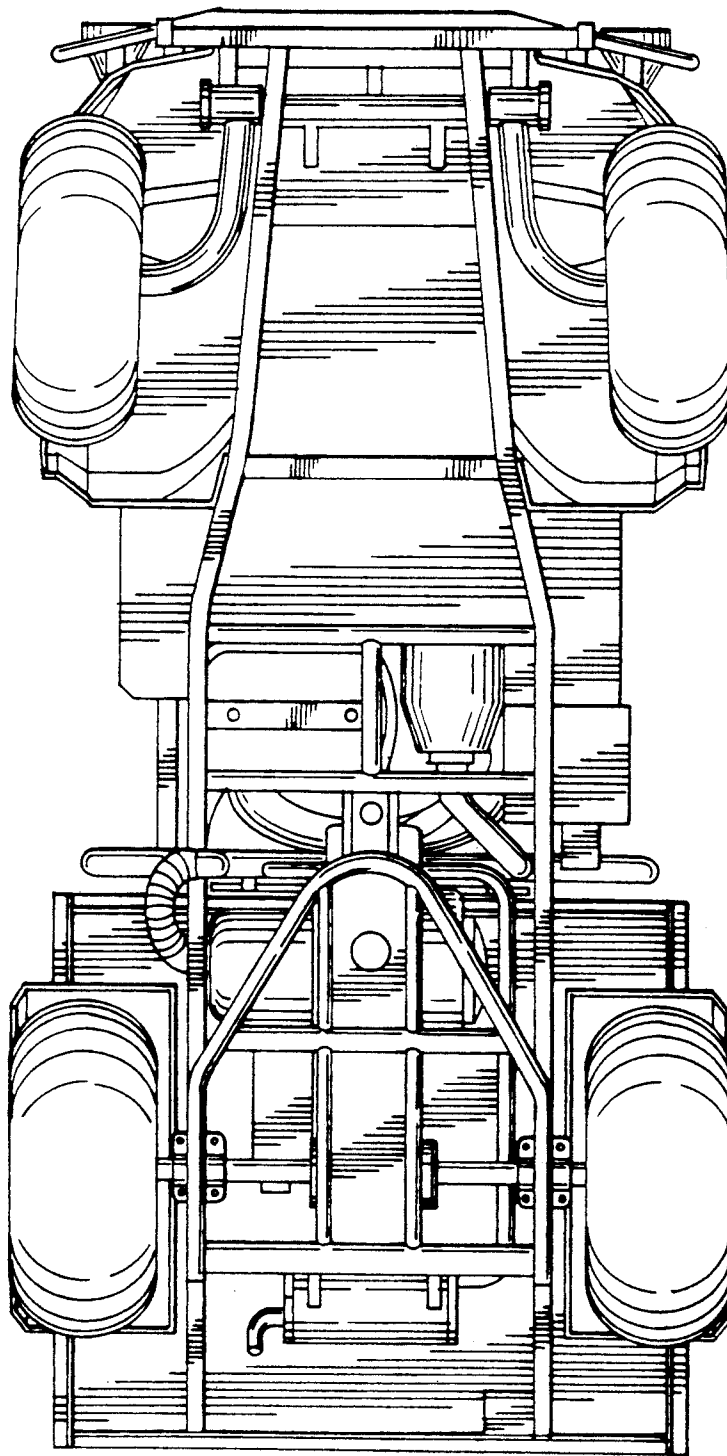

FIG. 7

