

C. BERZAC.  
 APPARATUS FOR TRAINING AND AMUSEMENT PURPOSES.  
 APPLICATION FILED APR. 27, 1910.

994,567.

Patented June 6, 1911.

2 SHEETS—SHEET 1.

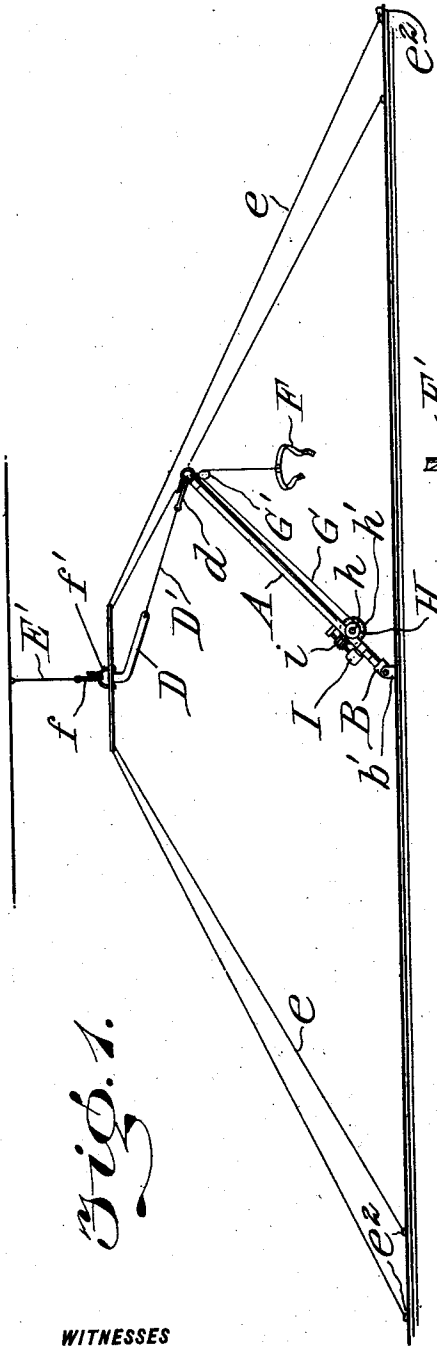

*Fig. 1.*

WITNESSES

*R. C. Abbott*  
*W. E. Freeman.*

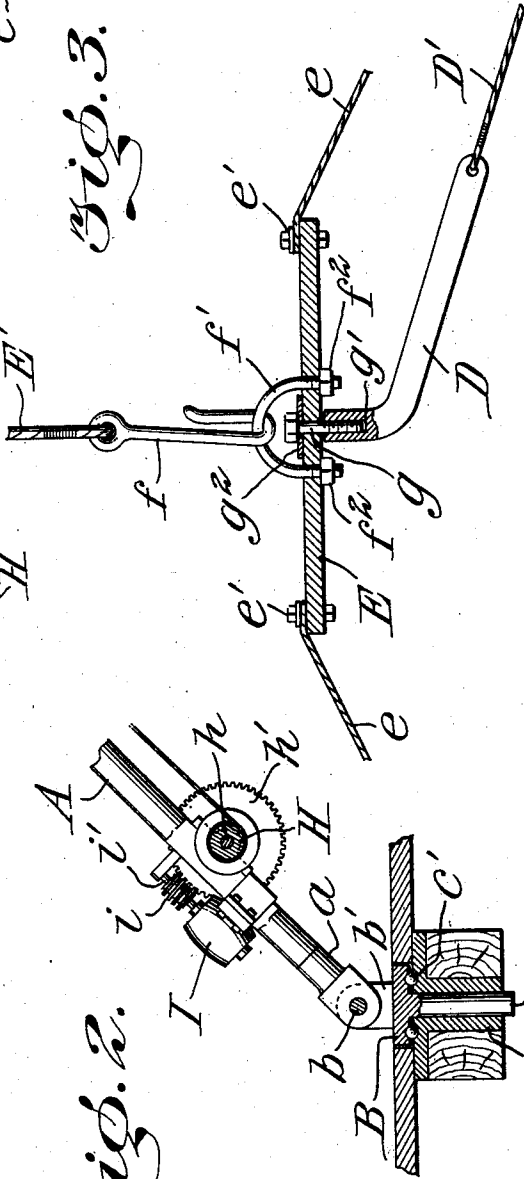

*Fig. 3.*

*Fig. 2.*

INVENTOR

*Cliff Berzac*

BY *Griffins Bernhard*  
 ATTORNEYS

C. BERZAC.  
 APPARATUS FOR TRAINING AND AMUSEMENT PURPOSES.  
 APPLICATION FILED APR. 27, 1910.

994,567.

Patented June 6, 1911.

2 SHEETS—SHEET 2.

*Fig. 5.*

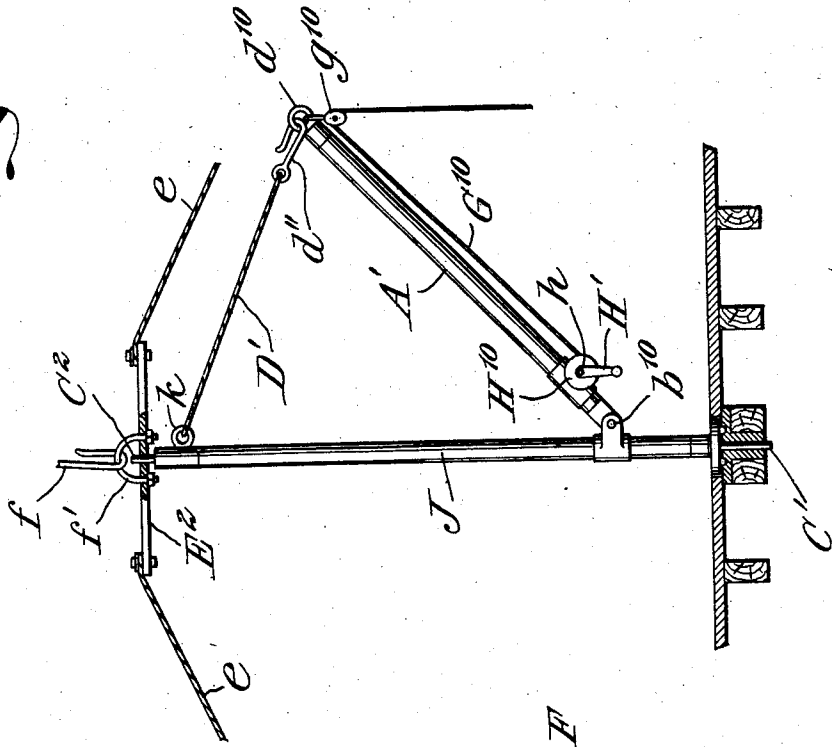

*Fig. 4.*

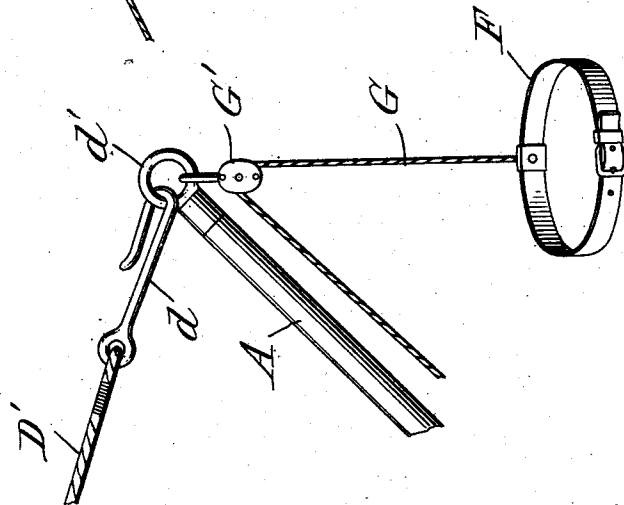

WITNESSES:

*R. C. Abbott*  
*W. E. Freeman*

INVENTOR

*Cliff Berzac*

BY

*Griffins Bernhard*

ATTORNEYS

# UNITED STATES PATENT OFFICE.

CLIFF BERZAC, OF NEW YORK, N. Y.

APPARATUS FOR TRAINING AND AMUSEMENT PURPOSES.

994,567.

Specification of Letters Patent.

Patented June 6, 1911.

Application filed April 27, 1910. Serial No. 558,047.

To all whom it may concern:

Be it known that I, CLIFF BERZAC, a subject of the King of Great Britain, residing in the city of New York, borough of Manhattan, county and State of New York, have invented a certain new and useful Apparatus for Training and Amusement Purposes, of which the following is a specification.

10 This invention is an apparatus, adapted for use, among other things, for training equestrians whereby bare back, and other difficult styles of riding horses, may be accomplished much more expeditiously, thoroughly, and with less danger of accident than has heretofore been possible.

15 As is well known, the skill required by circus, and similar riders, is acquired only after a great deal of patient, difficult and dangerous experience. The present invention overcomes, to a great extent, these and other difficulties, and embodies means whereby riders may perform all their preliminary work without danger, and in a manner to inspire them with confidence.

20 The apparatus is adapted for use, also, as an amusement apparatus, in that it enables inexperienced riders, *e. g.*, those selected indiscriminately from an audience, to attempt the performance of difficult feats, without fear of serious accident, and yet to the great amusement of the audience.

25 Broadly stated, the invention embodies a rotatable boom having suspended therefrom a device, such as a belt, for supporting the rider when necessary independently of the horse, or to enable him to mount or dismount, when desired, as well as to provide against accident to the rider.

30 It will be understood that the apparatus is not only intended for use in a circus, but may be used in any place of amusement, such as in vaudeville theaters, parks, etc.

35 In the accompanying drawings I have illustrated different practical embodiments of the invention, but the construction shown therein are to be understood as illustrative, only, and not as defining the limits of the invention.

40 Figure 1 is a side elevation of a training and amusement apparatus constructed in accordance with one embodiment of this invention. Fig. 2 is an enlarged view, partly in vertical section, of the lower end of the boom illustrating the means for rotatably supporting said boom and for operating the

cable which suspends the body belt. Fig. 3 is an enlarged vertical section through the suspended platform adapted for supporting the upper end of the rotatable boom. Fig. 4 is an elevation of a portion of the boom, the supporting cable therefor, and the cable which supports the body belt. Fig. 5 is an elevation, partly in section, illustrating another embodiment of the invention.

45 A designates a boom which is provided at its lower part with foot block, *a*. Said foot block is shown as being connected by a horizontal bolt, *b*, to a lug, *b'*, of a bearing block, B. The bearing block is provided with a depending pintle, *c*, which is free to rotate in a fixed supporting block, C, and between the bearing block and the foot block are interposed the rollers or balls, *c'*, of a ball or roller bearing whereby the foot block, B, is free to rotate with respect to the bearing block. The boom, A, is supported at its upper end by an arm, D, and a cable, D'. Said cable, D', is shown in Fig. 4 as having a hook, *d*, connected detachably to an eye, *d'*, at the upper free end of the boom, A. The arm, D, is rotatably supported on a platform, E, which is suspended from an elevated point of support by a cable, E', said platform, E, being held firmly in position by means of guy ropes, *e*. The guy ropes are fastened to the edge portion of platform, E, by any suitable means, such as the bolts, *e'*, while the lower ends of said guy ropes are fastened to stakes, *e''*, driven into the ground or to eyes upon the floor. The suspending cable, E', is fastened at its upper end to the ceiling, or to any other suitable supporting means, but the lower end of the cable is provided with a hook, *f*, which is detachably connected to a clevis, *f'*, the latter being secured by nuts, *f''*, to the central part of platform, E.

50 The rotating arm, D, is connected pivotally to the central part of platform, E, by suitable means, the same being herein shown as a bolt, *g*, which is screwed into a female threaded socket, *g'*, provided in an angular end of the rotating arm, D. The bolt, *g*, passes loosely through an opening provided in the platform, E, and the head of said bolt is shown in Fig. 3 as resting upon a washer, *g''*.

55 F designates a body belt of any suitable construction, the same being attached to the free end of a supporting cable, G. Said cable runs through a block, G', which is sus-

5 depended from the eye,  $d'$ , at the free end of boom, A. From the block said supporting cable, G, extends down to a windlass or drum, H, the latter being mounted for free rotation upon the boom, A, near the pivoted end thereof. The windlass, H, is adapted to be operated by any suitable means. As shown in Figs. 1 and 2, the shaft,  $h$ , of the windlass is provided with a worm gear,  $h'$ , which meshes with a worm,  $i$ , on the shaft,  $i'$ , of an electric motor, I, the latter being suitably attached to the rotatable boom, A. Current from any suitable source of energy is adapted to be supplied to the motor for the purpose of rotating it, and the motor in turn operates the worm and worm gear for the purpose of rotating the windlass so as to coil the cable, G, upon said windlass, or to uncoil the cable therefrom. The intermeshing worm and worm gear provide means for locking the cable, H, from rotation when the motor is at rest. Instead of operating the windlass by the motor and gearing described, said windlass may be operated by a hand crank,  $H'$ , which is secured to the windlass shaft,  $h$ , as shown in Fig. 5. The hand crank is the equivalent of the electric motor as a means for operating the windlass, but either of these devices, or any equivalents thereof, may be employed in my apparatus.

30 The operation of the apparatus shown in Figs. 1 to 4, inclusive, is evident from the foregoing description taken in connection with the drawings. The body belt, F, is fastened around the body of the performer or acrobat, and the cable, G, is adjusted so as to allow the performer to stand upon the back of a horse. The animal is trained to travel in a circuit around the boom, A, and the boom is pushed around by an attendant who should be stationed at the switch controlling the motor, or at the crank,  $H'$ , for operating the windlass. Should the animal swerve out of a prescribed path, the rider is prevented from falling by the body belt which is suspended by cable, G, from the boom. Of course, the boom is pushed around by the attendant so that it will travel at a speed equal to the speed of the animal. By mounting the boom for free rotation in the roller bearing and by supporting the free end of the boom from the rotatable arm, D, very little effort is required to rotate the boom at the required speed. It is evident, furthermore, that the rotatable arm, D, will turn freely on the axis afforded by the vertical bolt so that the arm, D, will travel or rotate with the boom.

60 Should the rider fall off the horse, he is prevented from falling to the ground by the body belt and the cable, the windlass, H, being under the control of the attendant, the performer may be lowered safely to the ground, or the animal may be driven into a position where the performer may easily re-

70 sume a position upon the back of the animal. Should it be desired, the cable, G, may be slackened to a sufficient extent for the performer to leap from the ground to the back of the horse, or to dismount easily, but ordinarily the apparatus is arranged so that there is a certain amount of tension on the operating cable, G, for the purpose of preventing the performer from falling to the ground should he lose his footing upon the back of the animal.

75 The apparatus shown in Fig. 5 includes a mast, J, which is stepped at its lower end in a bearing,  $C'$ , and is rotatably supported by a pintle,  $C^2$ , in a platform,  $E^2$ , the latter being suspended and stayed by devices heretofore described in connection with a platform, E, of Figs. 1 and 3. The mast, J, carries a boom,  $A'$ , which is supported in a prescribed position by a cable,  $D'$ , the latter being attached at one end to an eye,  $k$ , at the upper end of the mast. The boom,  $A'$ , is pivotally connected by a bolt,  $b^{10}$ , to the mast, and on this boom is supported a windlass,  $H^{10}$ . The free end of the boom is provided with an eye,  $d^{10}$ , to which is connected a hook,  $d^{11}$ , and the block,  $g^{10}$ . The supporting cable,  $G^{10}$ , is coiled upon the drum,  $H^{10}$ , and runs through the block,  $g^{10}$ , said cable being provided at its free end with a body belt similar to the belt, F, of Figs. 1 and 4. The mode of using the apparatus of Fig. 5 is substantially the same as that heretofore described in connection with the apparatus of Figs. 1 to 4, inclusive.

100 From the foregoing description taken in connection with the drawings it will be observed that the several parts composing my apparatus may be readily assembled and erected so that the apparatus can be quickly installed for use, and at the same time these several parts may be disconnected in order that they may be packed or stored within a small compass.

105 The entire apparatus is simple in construction, easy of operation, and economical in manufacture.

110 Having thus fully described the invention, what I claim as new, and desire to secure by Letters Patent is:

115 1. In an apparatus for training and amusement purposes, a boom mounted for rotation on a vertical axis and adapted to be moved relatively to a path to be traversed by an animal, a device suspended from the boom and adapted to be attached to a rider of the animal, and a windlass mounted upon the boom for rotation therewith, said windlass being operatively connected with said device for supporting the rider should the latter become dismounted accidentally from the animal.

120 2. In an apparatus for training and amusement purposes, a boom rotatable relative to the path to be traversed by an animal under-

70  
75  
80  
85  
90  
95  
100  
105  
110  
115  
120  
125  
130

going training or to be engaged in a performance, a device suspended from the boom and attachable to the person of a performer to be engaged in riding the animal, a windlass supported by, and rotatable with, said boom, and a cable coiled on the windlass and connected with said device for supporting the weight of the performer in the event of the latter becoming dismounted from the animal.

3. In an apparatus of the class described, a rotatable boom, a rotatable arm connected to said boom, said arm operating to support the boom at an angle relative to a path to be traversed by an animal to be trained or to be engaged in a performance, and supporting means connected to the boom.

4. In an apparatus of the class described, a rotatable boom, a rotatable arm connected to said boom, said arm operating to support the boom at an angle relative to a path to be traversed by an animal to be trained or to be engaged in a performance, a belt connected to the boom and adapted to be secured to the rider, and means for raising and lowering said belt.

5. In an apparatus of the class described, a rotatable boom, a platform or supporting device, means for supporting said platform, a rotatable arm mounted on the platform and connected to said boom, and means for supporting a rider, connected to the boom.

6. In an apparatus for training and amusement purposes, an overhead platform, a boom rotatable relative to the path to be traversed by an animal to be trained or to be engaged in a performance, a boom-supporting member pivoted to the platform and connected to said boom for retaining the lat-

ter at an angle to the path to be traversed by the animal, a device attachable to the person of a performer for supporting the latter's weight in the event of displacement from the animal, and operating means rotatable with the boom and connected to said device.

7. In an apparatus of the class described, a suspended overhead platform, an arm pivotally supported by the platform, a pivoted boom connected at its upper portion to the arm, and means carried by the boom for supporting a rider.

8. In an apparatus for training and amusement purposes, a boom rotatable relative to the path to be traversed by an animal to be trained or to be engaged in a performance, an operating drum mounted upon the boom for movement therewith, a cable guided on the boom and wound upon the drum, a body belt attached to a cable and attachable to the person of a performer adapted to ride the animal, and means for operating the drum at will whereby the weight of a performer is adapted to be suspended from the boom in the event of said performer becoming dismounted from the animal.

9. In an apparatus of the class described, a rotatable foot block, a boom pivoted to the foot block and adapted for rotation therewith, means for supporting the free end of the boom, and means carried by the boom for supporting a rider.

In testimony thereof I have signed my name to this specification in the presence of two subscribing witnesses.

CLIFF BERZAC.

Witnesses:

H. I. BERNHARD,  
JAS. H. GRIFFIN.