

(12) **UK Patent Application** (19) **GB** (11) **2 368 979** (13) **A**

(43) Date of A Publication 15.05.2002

(21) Application No **0200741.7**

(22) Date of Filing **14.11.1997**

Date Lodged **14.01.2002**

(62) Divided from Application No **9724174.9** under Section **15(4)** of the Patents Act 1977

(71) Applicant(s)

**Chiu-Shan Lee**  
**No 23, Lane 19, Chang-Chun Road, Hsintien City,**  
**Taipei Country, Taiwan**

**Shen Su Chen Li**  
**No 23, Lane 19, Chang-Chun Road, Hsintien City,**  
**Taipei Country, Taiwan**

(72) Inventor(s)

**Chiu-Shan Lee**  
**Shen Su Chen Li**

(51) INT CL<sup>7</sup>  
**H01R 27/00**

(52) UK CL (Edition T )  
**H2E ECS D E C S H**

(56) Documents Cited  
**None**

(58) Field of Search  
INT CL<sup>7</sup> **H01R 27/00**  
Online databases: **EPODOC**

(74) Agent and/or Address for Service  
**Boult Wade Tennant**  
**Verulam Gardens, 70 Gray's Inn Road, LONDON,**  
**WC1X 8BT, United Kingdom**

(54) Abstract Title

**An electrical adapter for connection in series**

(57) The adaptor comprises a body 1 having a plug 532 and a socket 533 on opposite sides so that a plurality of adaptors can be connected in series by plugging the plug of one adapter into the socket of another. A coupling groove 15 and a pair of coupling plates 14 extend longitudinally along opposite sides of the body so that the coupling groove of one adapter can receive the coupling plates of another adapter. A tie hole extends through the end of the coupling plates so that a screw can extend therethrough and couple the adapters together. The adapter body may be used with telephone jacks and plugs or coaxial cable connectors (Figs 15 and 16).

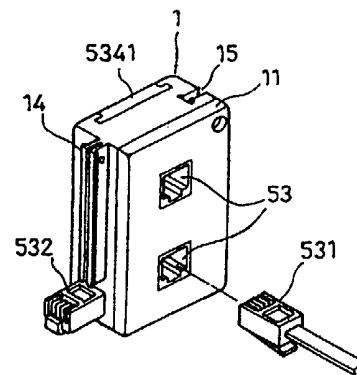

FIG.13

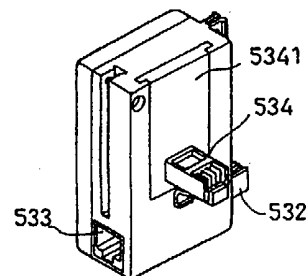

FIG.14

**GB 2 368 979 A**

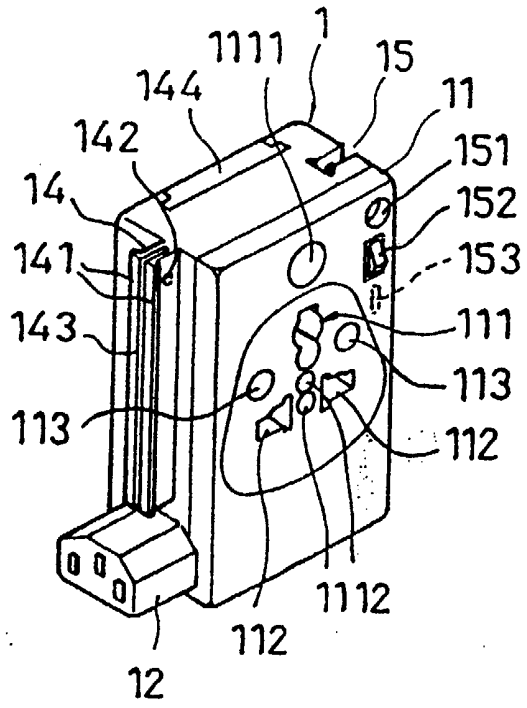

FIG. 1

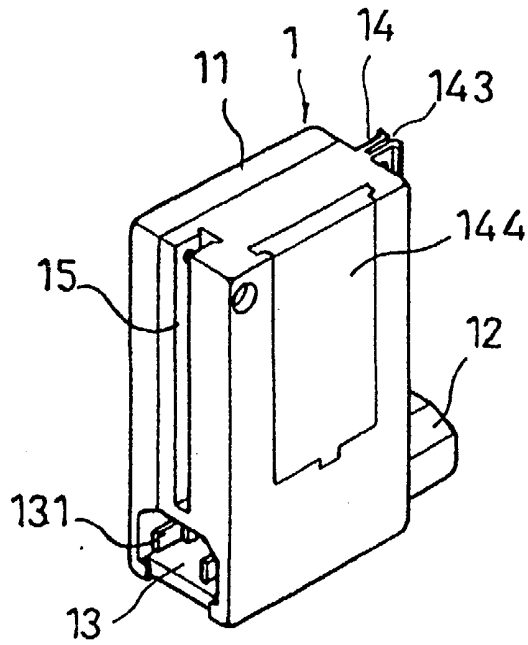

FIG. 2

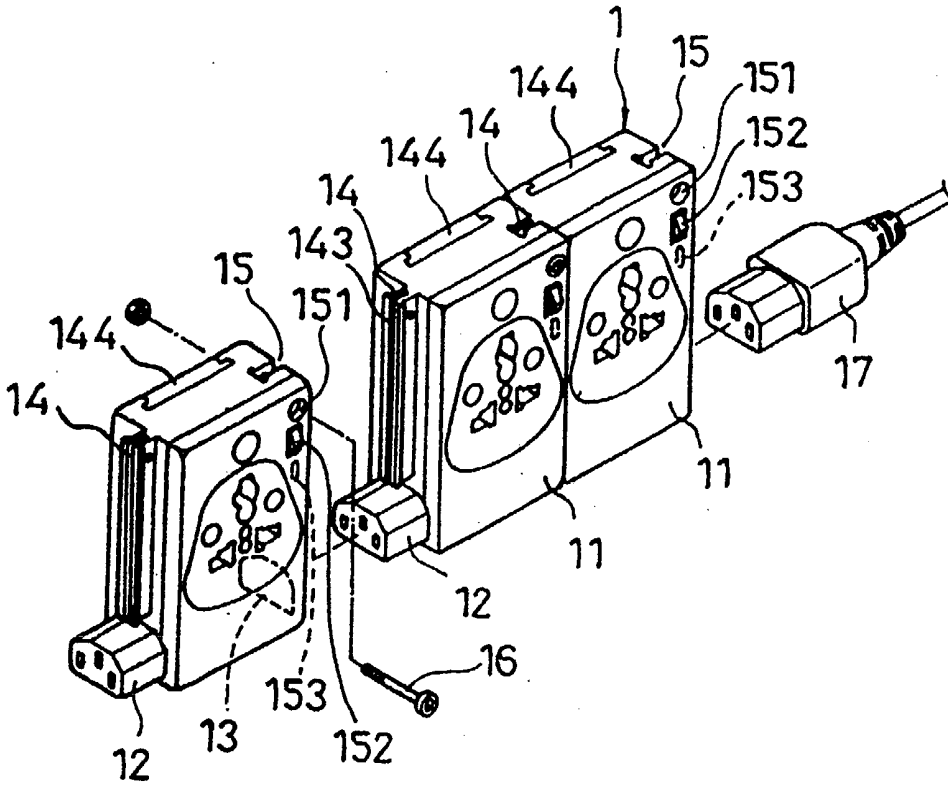

FIG. 3

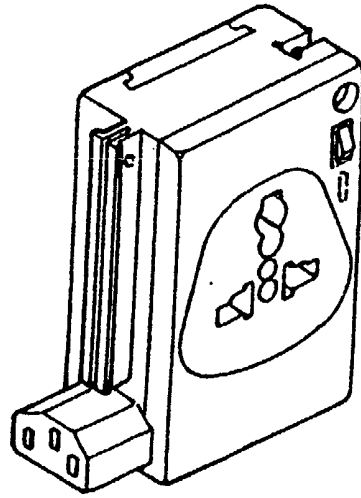

FIG.3A

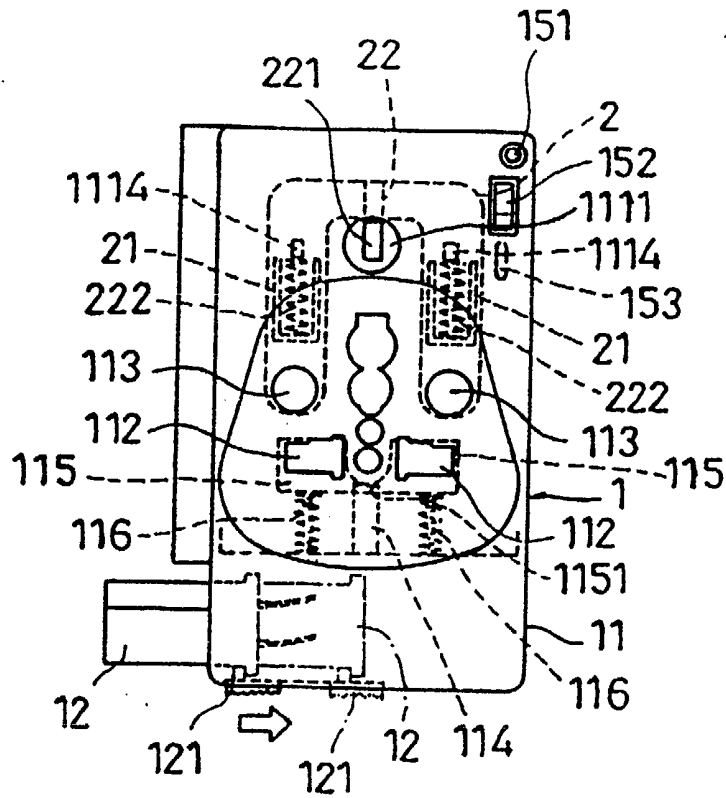

FIG. 4

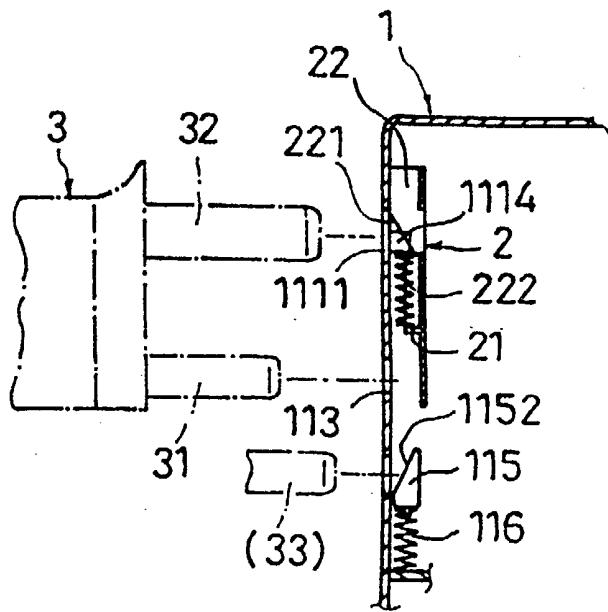

FIG. 5

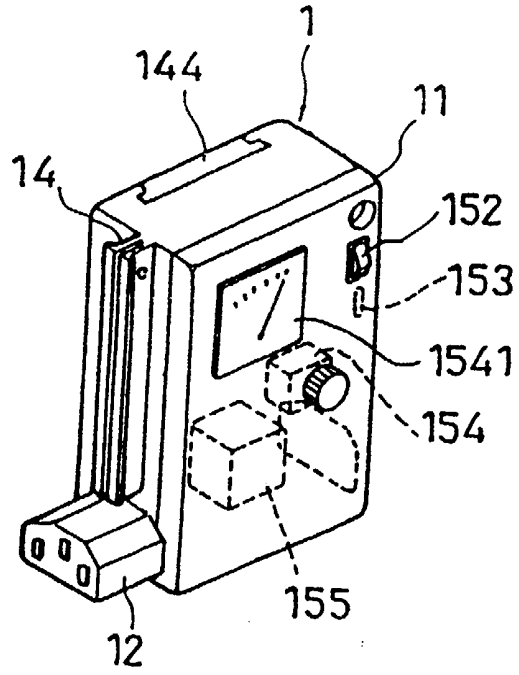

FIG. 5A

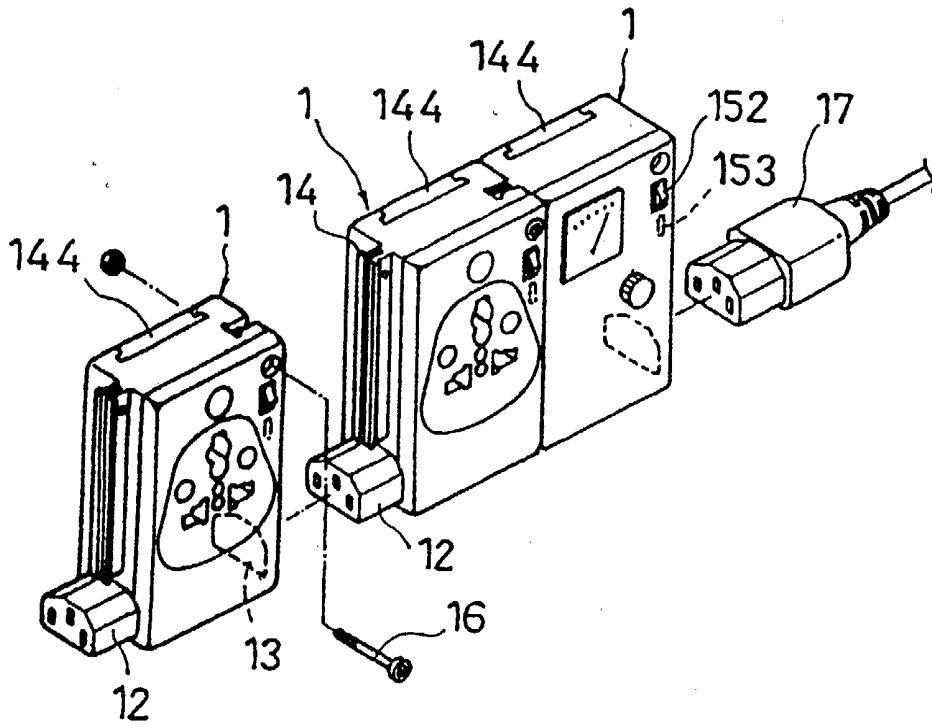

FIG. 5B

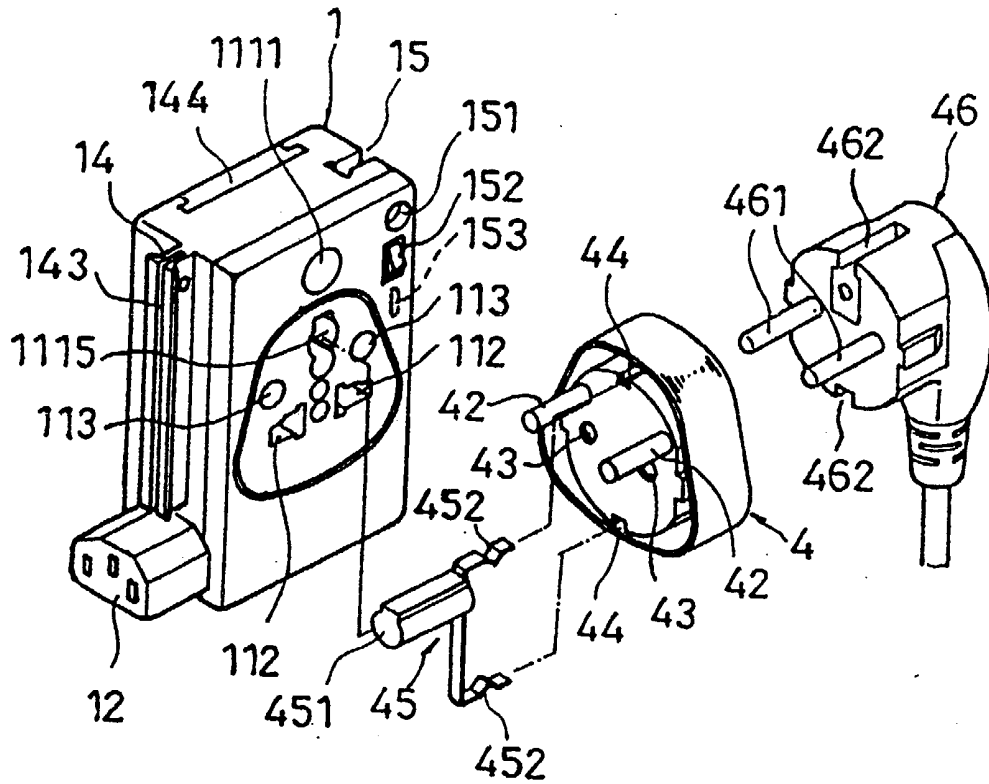

FIG. 6

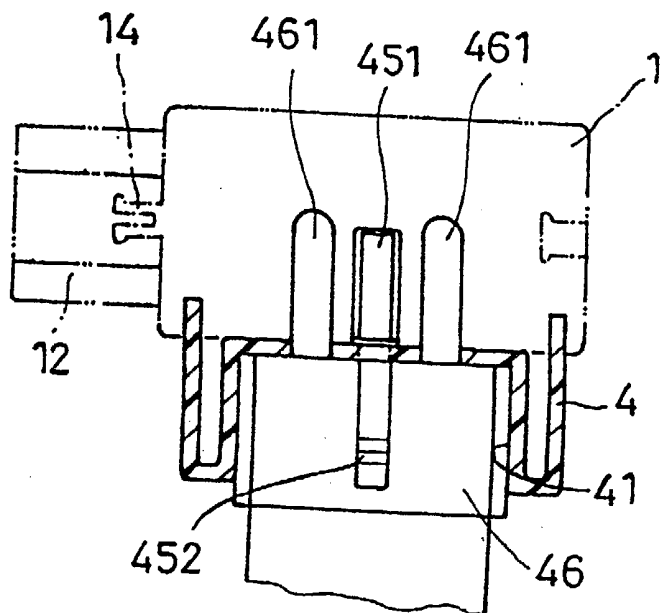

FIG. 7

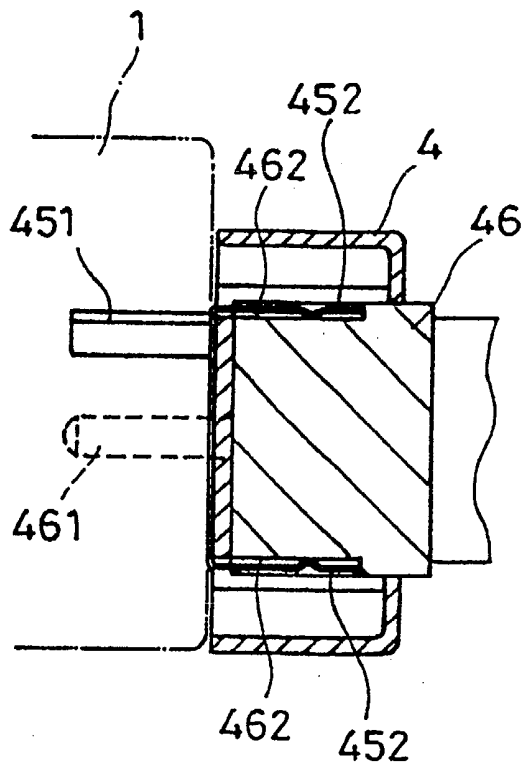

FIG.7A



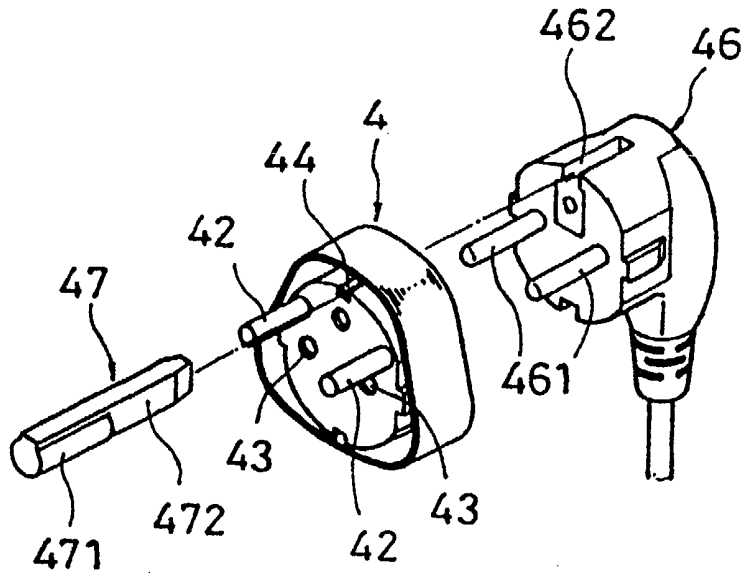

FIG.7B

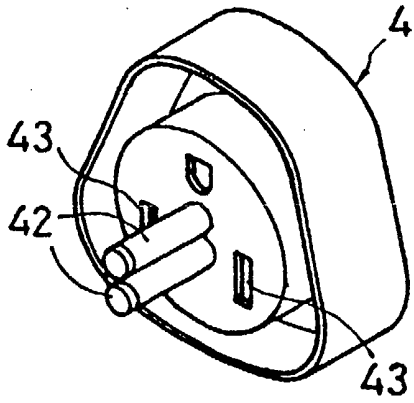

FIG. 7C

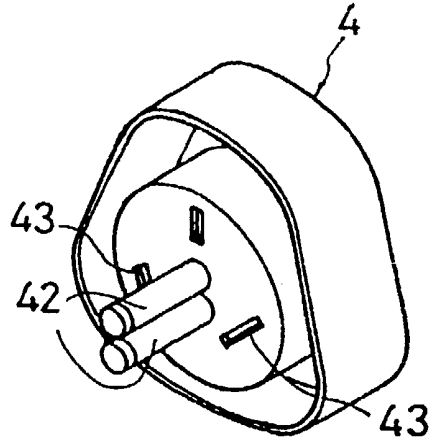

FIG. 7F

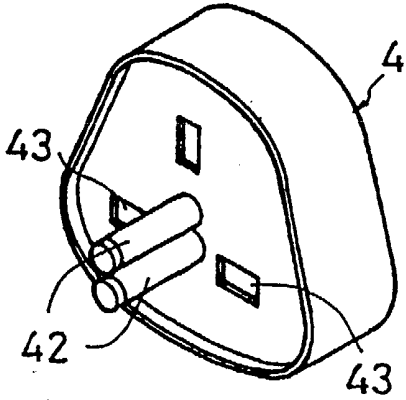

FIG. 7D

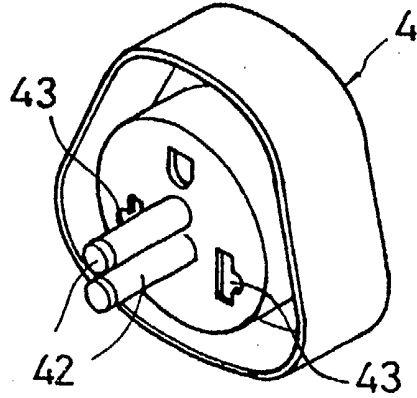

FIG. 7G

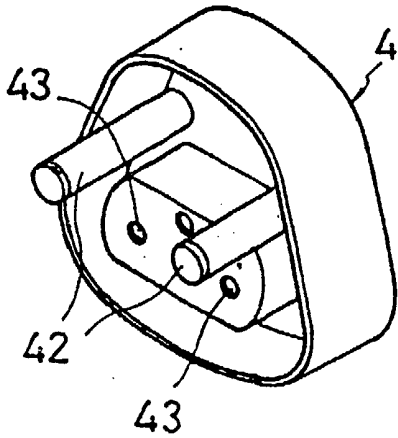

FIG. 7E

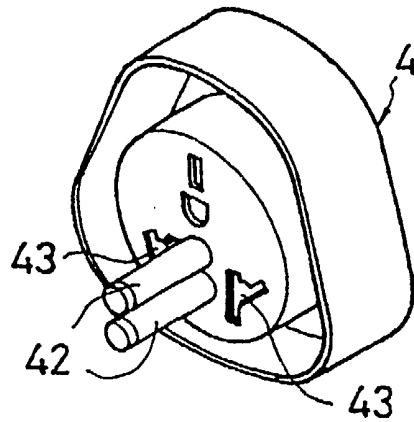

FIG. 7H

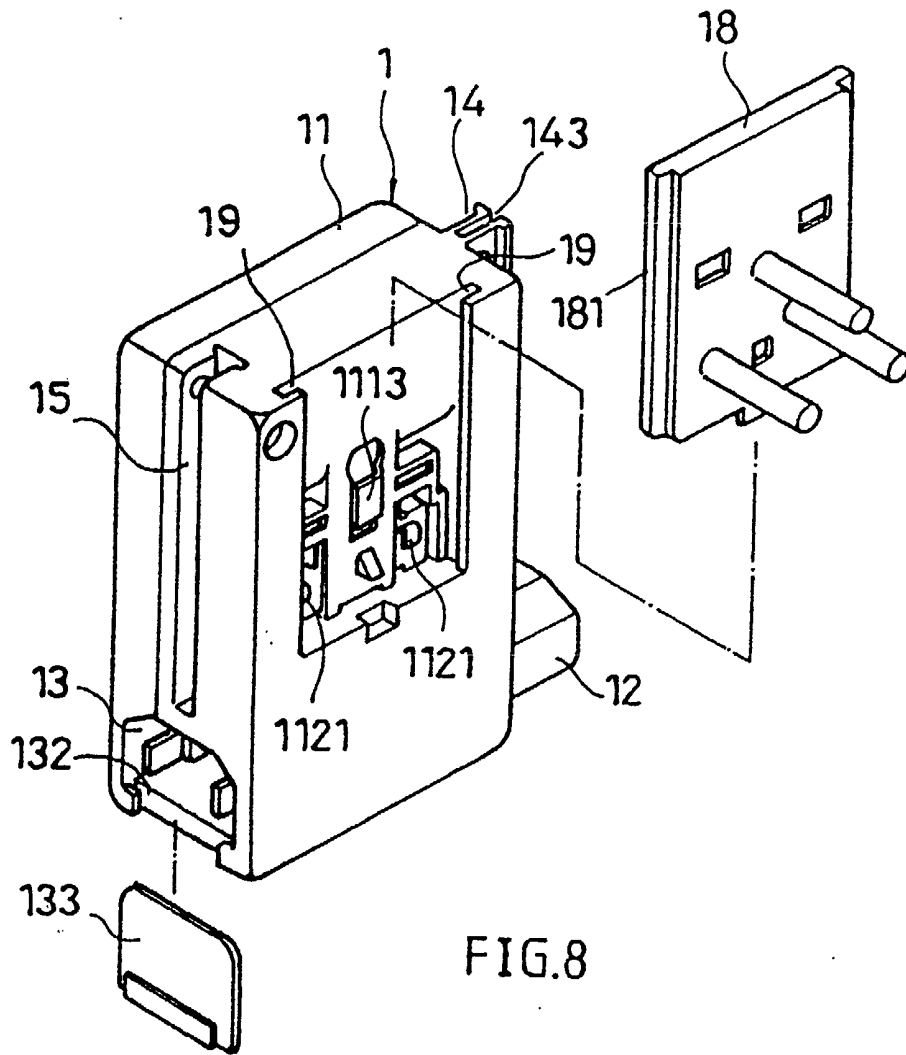

FIG. 8

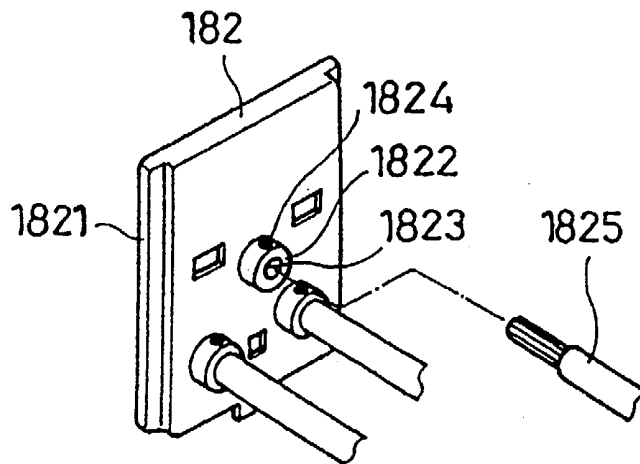
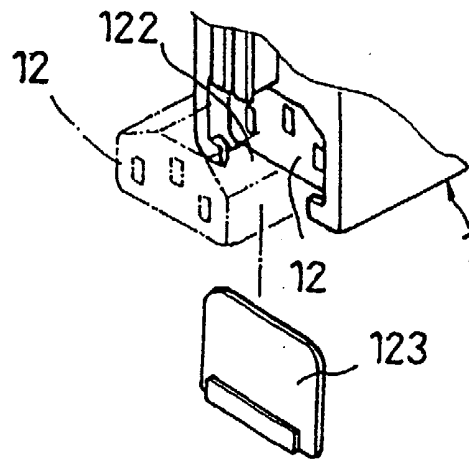
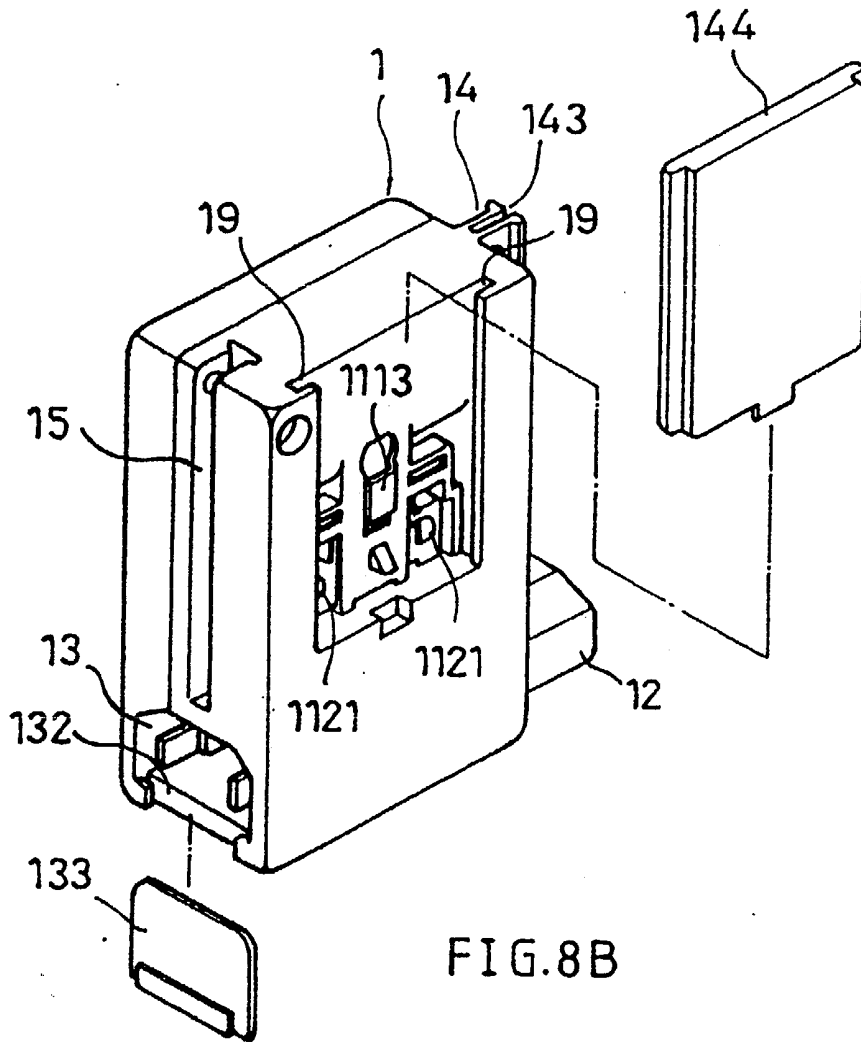

FIG. 8A



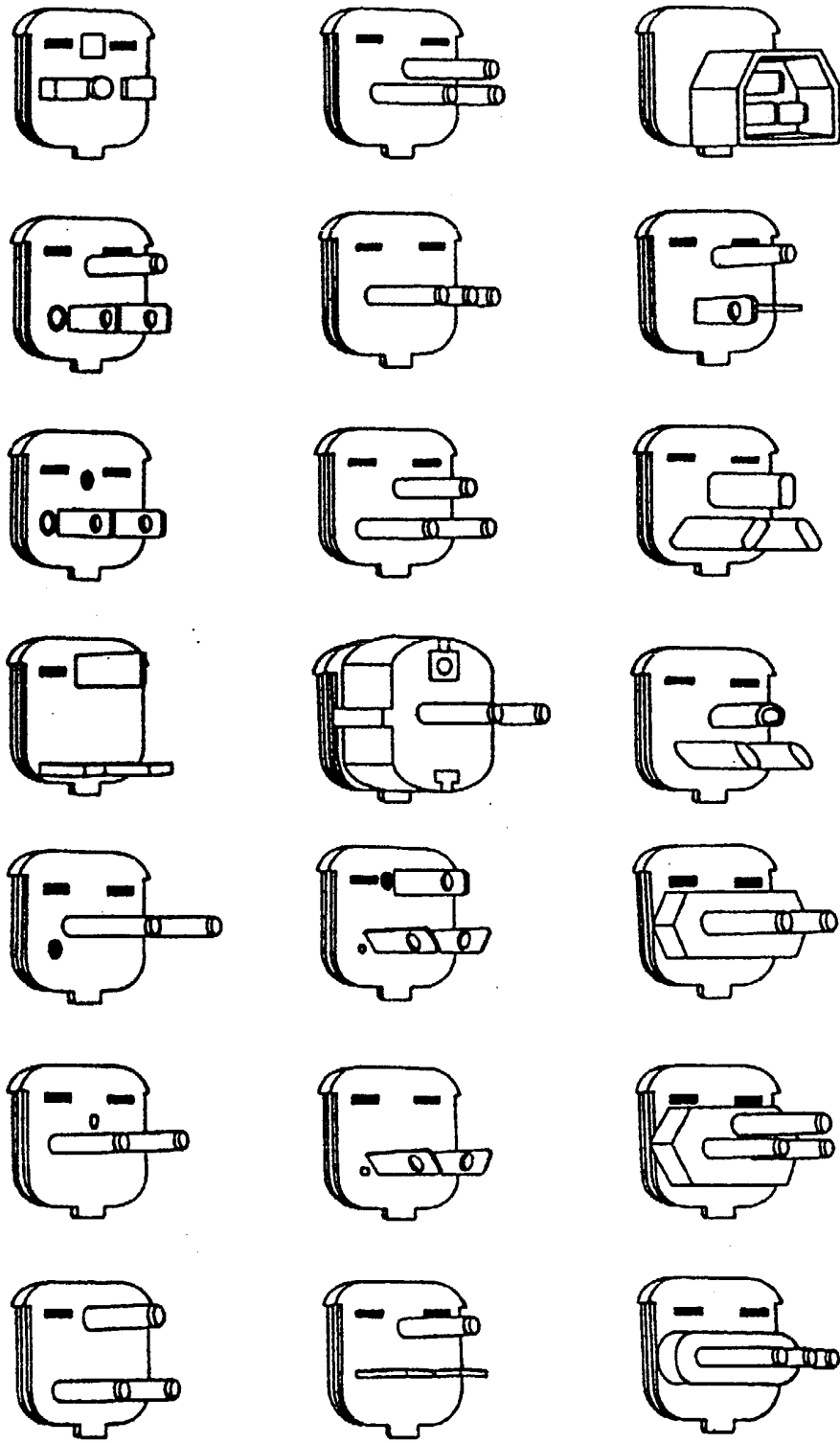

FIG. 9

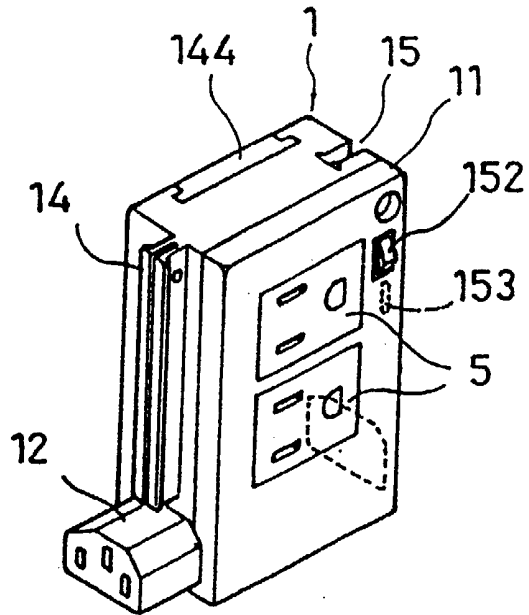

FIG. 10

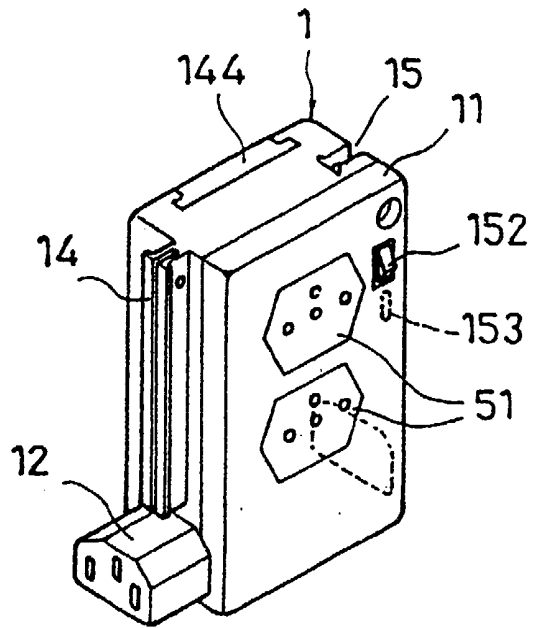

FIG. 11

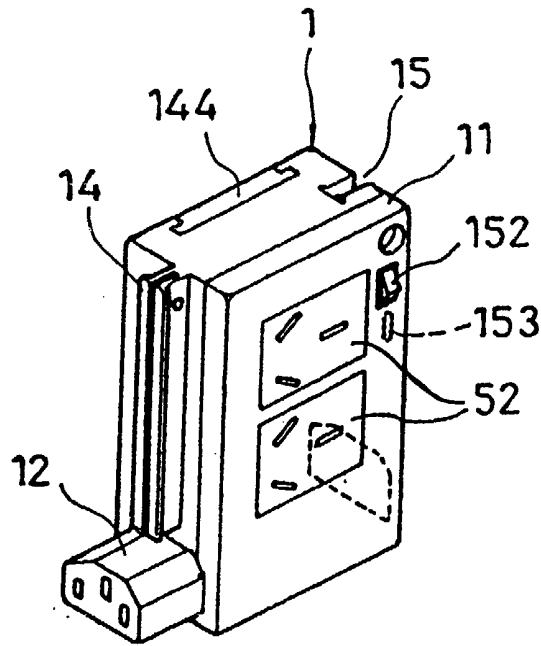

FIG. 12

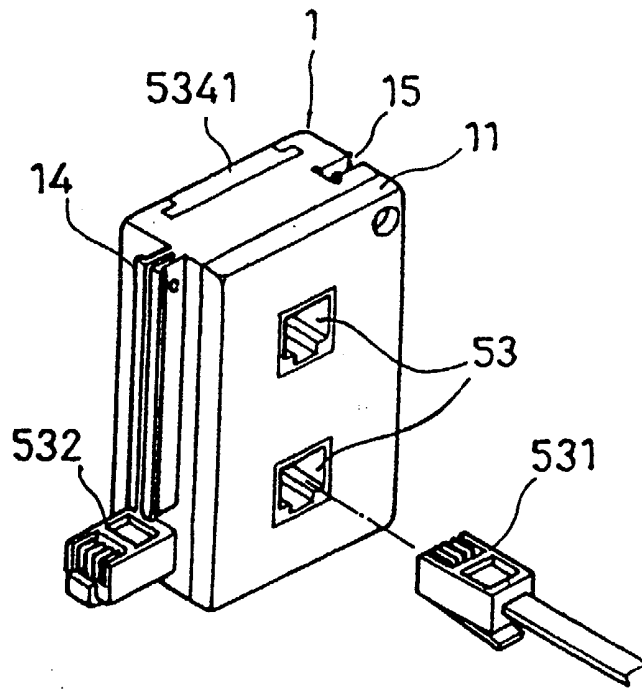

FIG. 13

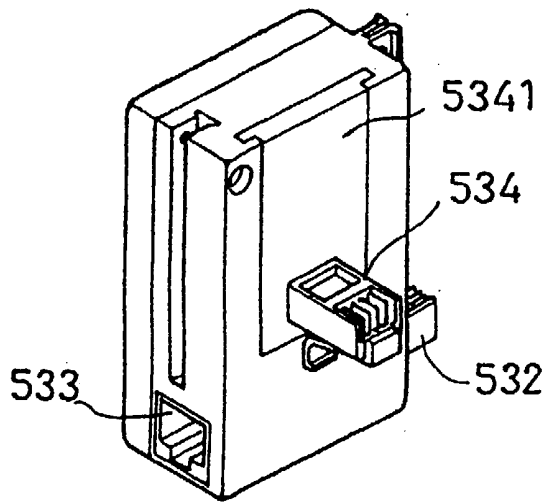

FIG. 14



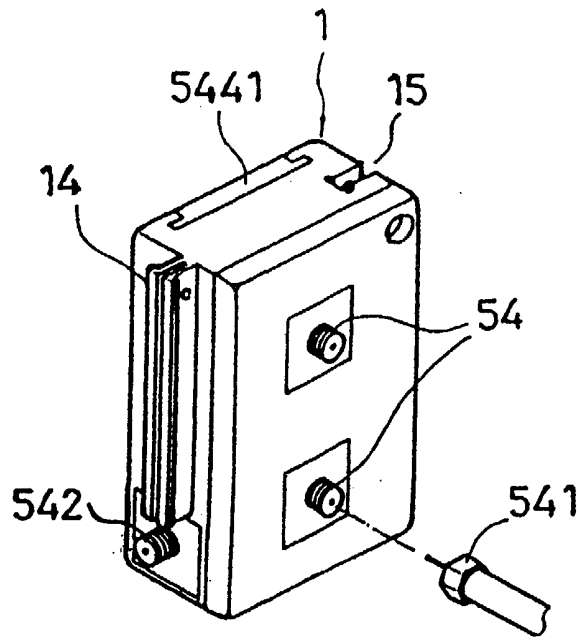

FIG.15

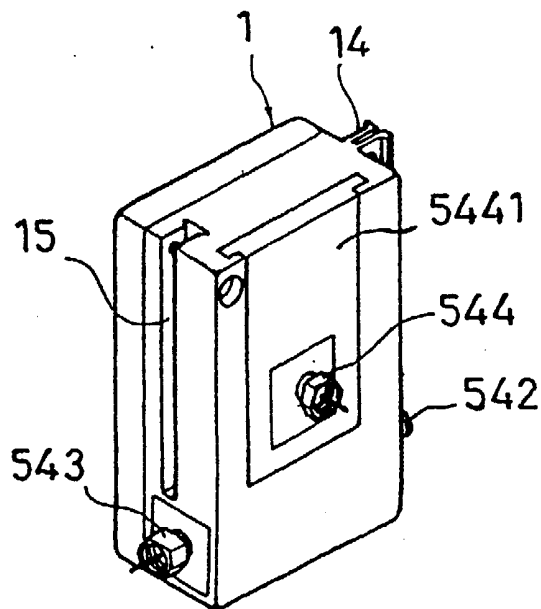

FIG.16

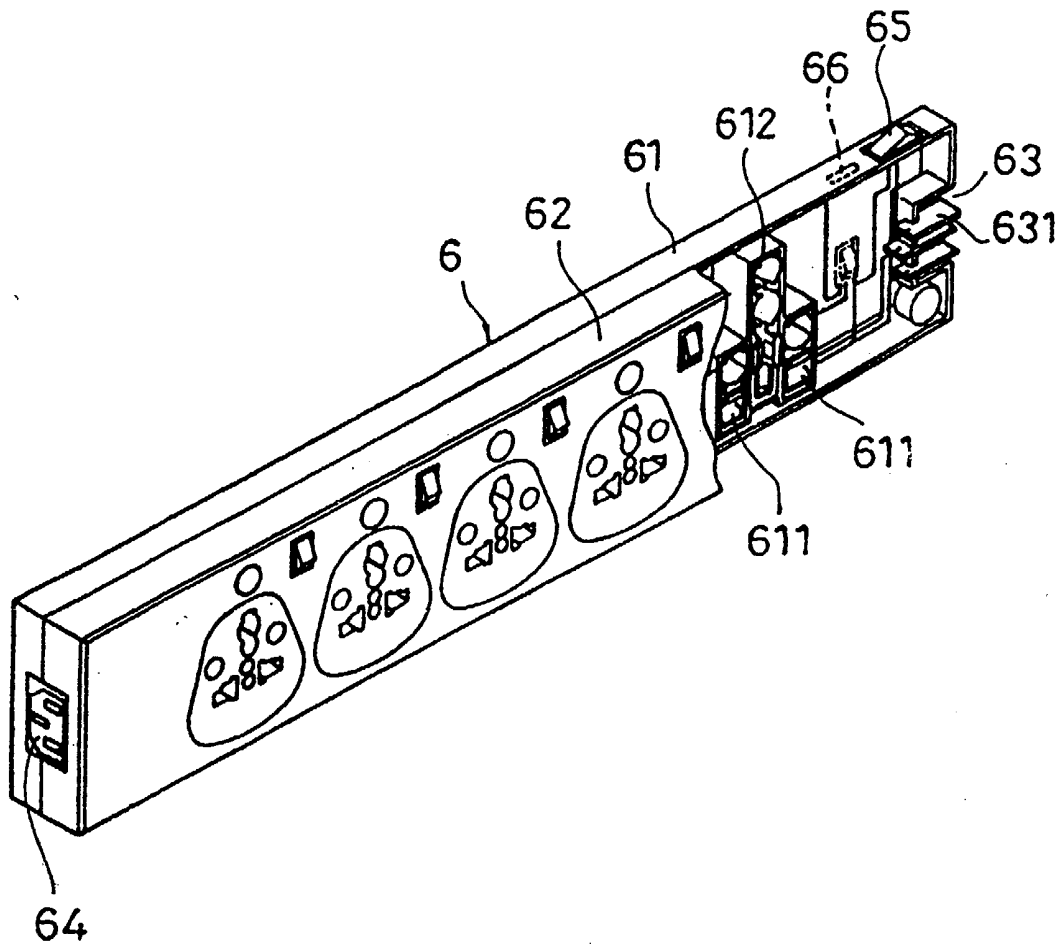

FIG.17

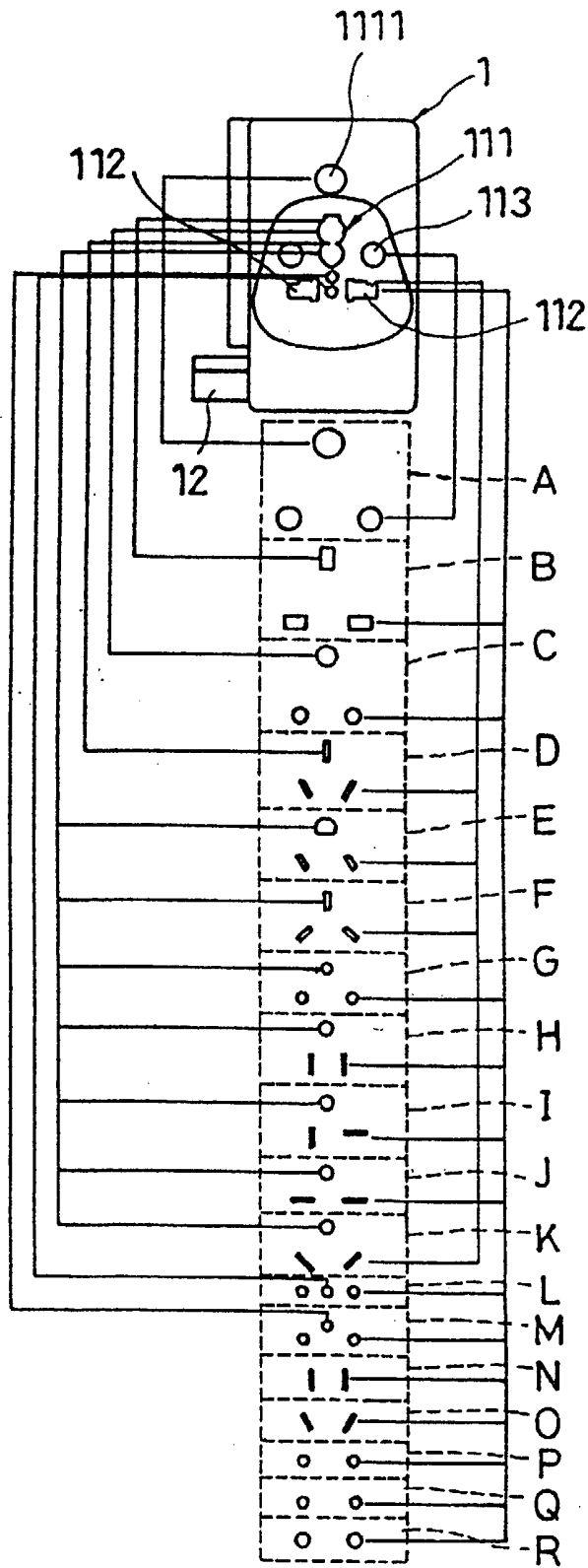

FIG.18

CODE	APPLICATION AREA	SPECIFICATION
A	British standards: South Africa	15A250V
B	British standards: HK, Malaysia, Uganda, Singapore, Arabian countries	13A250V
C	British colonies, India	5A250V 15A250V
D	China, New Zealand, Australia	10A250V
E	Denmark	15A250V
F	Middle East	15A250V
G	Middle East	15A250V
H	American standards: Taiwan, Japan, USA, Canada, Cuba, Venezuela, Costa Rica, Guam Dominique, Ecuador, Hawaii, Salvador, Haiti, Honduras, Mexico, Panama, Nicalagua	125V
	Philippines, Thailand, Guatemala, Paragua	250V
I	Taiwan, Japan, USA, Canada	20A250V
J	Taiwan, Japan, USA, Canada	15A250V
K	China	
L	Italy	10-16A250V
M	Swiss	10-16A250V
N	Taiwan, Japan, USA, Canada	15V125V
	China, Philippines, Thailand	250V
O	Chian, New Zealand, Australia	250V
P	Russia, Europe	small electric home appliance 250V
Q	German, Europe (with side grounding)	10-16A250V
R	Conventional British and Hong Kong Types	250V

FIG.18A

## ADAPTERS

BACKGROUND OF THE INVENTION

The present invention relates to electrical adapters, and relates more particularly to such an electrical adapter which is so designed that a plurality of the same electrical adapters can be conveniently connected in series.

A variety of electrical plugs and sockets have been developed and intensively used for different electrical apparatus. Further, different countries have different specifications on electrical plugs and sockets. In order to connect different electrical plugs to different electrical sockets, different electrical adapters may be used. It is not economic to prepare a variety of electrical adapters simply for use in few chances.

SUMMARY OF THE INVENTION

The present invention has been accomplished under the circumstances in view. It is the main object of the present invention to provide an electrical adapter which can be used to connect a variety of electrical plugs to a variety of electrical sockets. According to the present invention, the electrical adapter comprises an adapter body, a face panel covered on a front side of the adapter body, and an electrical circuit mounted inside the adapter body, wherein the face panel comprises a plurality of

grounding prong insertion holes longitudinally aligned in the middle adapted to receive grounding prongs of different electrical plugs, two first power contact blade insertion holes and two second power contact blade insertion holes bilaterally disposed at  
5 different elevations and adapted to receive power contact blades of different electrical plugs, a backward guide rod, a first sliding cover coupled to the backward guide rod by a slip joint and adapted to close the first power contact blade insertion holes, the first sliding cover having an upwardly backwardly extended sloping  
10 guide face at a front side corresponding to one grounding prong insertion hole, the first sliding cover being downwardly moved away from the first power contact insertion holes when a grounding prong of an electrical plug is inserted into one grounding prong insertion hole and forced against the sloping guide face of the first  
15 sliding cover, first spring means adapted to impart an upward pressure to the first sliding cover, causing the first sliding cover to close the first power contact blade insertion holes, a second sliding cover adapted to close the second power contact blade insertion holes, the second sliding cover having a top block at a front side  
20 thereof in the middle, the top block having a sloping guide face in the middle corresponding one grounding prong insertion hole, the top block being forced to move the second sliding cover upwardly

away from the second power contact blade insertion holes when a grounding prong of an electrical plug is inserted into one grounding prong insertion hole and forced against the sloping guide face of the top block, second spring means adapted to impart  
5 a downward pressure to the second sliding cover, causing the second sliding cover to close the second power contact blade insertion holes; the adapter body comprises a plug unit at a first lateral side thereof and a socket unit at a second lateral side thereof, the size of the plug unit fitting that of the socket unit so that a  
10 plurality of electrical adapters can be connected in series by plugging the plug unit of one electrical adapter into the socket unit of another, a longitudinal coupling groove at its first lateral side and a pair of longitudinal coupling plates at its second lateral side, a tie hole pierced through one corner thereof and intersected with  
15 the longitudinal coupling groove, the longitudinal coupling plates having a respective through hole, the longitudinal coupling plates and the longitudinal coupling groove being so arranged that the longitudinal coupling plates of one electrical adapter are fitted into the longitudinal coupling groove of another when a plurality of  
20 electrical adapters are connected in series, permitting the through holes of the longitudinal coupling plates of one electrical adapter to be fastened to the tie hole of another electrical adapter by a

fastening element.

### BRIEF DESCRIPTION OF THE DRAWINGS

Fig. 1 is a perspective view of an electrical adapter according to a first embodiment of the present invention.

5 Fig. 2 is another perspective view of the electrical adapter shown in Figure 1 when taken from another angle.

Fig. 3 is an applied view of the first embodiment of the present invention, showing a plurality of electrical adapters connected in series.

10 Fig. 3-A shows an alternate form of the electrical adapter according to the first embodiment of the present invention.

Fig. 4 is a front plain view of the electrical adapter shown in Figure 1.

15 Fig. 5 is a side view in section of the electrical adapter shown in Figure 1.

Fig. 5-A is a perspective view of an electrical adapter according to a second embodiment of the present invention.

20 Fig. 5-B shows an electrical adapter of the second embodiment connected to an electrical adapter of the first embodiment according to the present invention.

Fig. 6 is an exploded view of an electrical adapter according to a third embodiment of the present invention.



Fig. 7 is a top plain view showing the assembly of Figure 6 assembled.

Fig. 7-A is a side plain view of Figure 7.

Fig. 7-B is an exploded view of a part of an alternate form of the third embodiment of the present invention.

Figs. 7-C~7-H show different alternate forms of the electrical adapter according to the third embodiment of the present invention.

Fig. 8 is an exploded view of an electrical adapter according to a fourth embodiment of the present invention.

Fig. 8-A is an exploded view of a back board for an electrical adapter according to a fifth embodiment of the present invention.

Fig. 8-B shows an alternate arrangement of the fifth embodiment of the present invention.

Fig. 8-C is an exploded view of a part of the fifth embodiment of the present invention, showing the plug unit retracted from the extended position.

Fig. 9 shows different alternate forms of the plug member for the electrical adapter according to the fourth embodiment of the present invention.

Fig. 10 is a perspective view of an electrical adapter

according to a sixth embodiment of the present invention.

5 Figure 11 shows an alternate form of the sixth embodiment of the present invention;

Figure 12 shows another alternate form of the sixth embodiment of the present invention;

10 Figure 13 is a perspective view of an electrical adapter according to a seventh embodiment of the present invention;

Figure 14 is another perspective view of the electrical adapter shown in Figure 13 when taken from another angle;

15 Figure 15 is a perspective view of an electrical adapter according to an eight embodiment of the present invention;

Figure 16 is another perspective view of the electrical adapter shown in Figure 15 when taken from another angle;

20 Figure 17 is a perspective view of an electrical adapter according to a ninth embodiment of the present invention;

Figure 18 shows a face panel with insertion holes for electrical plugs of different specifications;

25 Figure 18-A shows a insertion hole-application country comparison table according to the present invention.

#### DETAILED DESCRIPTION OF THE PREFERRED EMBODIMENTS

30

Referring to Figures from 1 to 5, an electrical adapter 1 is shown comprises a face panel 11 at its front side. The face panel

11 has a plurality of grounding prong insertion holes 1111;111;1112 longitudinally aligned in the middle, two first power contact blade insertion holes 112 bilaterally disposed at a lower elevation, two second power contact blade insertion holes 113 bilaterally disposed in the middle above the first power contact blade insertion holes 112. The first power contact blade insertion holes 112 are adapted to receive power contact blades of a variety of electrical plugs. The second power contact blade insertion holes 113 are adapted to receive power contact blades of an electrical plug made subject to related specifications issued by the Republic of South Africa. A guide rod 114 is provided at the back side of the face panel 11 inside the electrical adapter 1. A first sliding cover 115 is coupled to the guide rod 114 inside the electrical adapter 1 by a slip joint. The first sliding cover 115 has a longitudinal sliding slot 1151 in the middle, which receives the guide rod 114. Two spring elements 116 are mounted inside the electrical adapter 1 to support the first sliding cover 115. The spring elements 116 impart an upward pressure to the first sliding cover 115, thereby causing the first sliding cover 115 to close the first power contact blade insertion holes 112. The first sliding cover 115 has an upwardly backwardly extended sloping guide face 1152 at its front side. When two power contact blades 32 of an

○ electrical plug 3 are respectively inserted into the first power contact blade insertion holes 112, they are perpendicularly forced against the sloping guide face 1152 of the first sliding cover 115, thereby causing the first sliding cover 115 to be lowered, for 5 permitting the power contact blades 32 of the electrical plug 3 to be respectively inserted into position. A plug unit 12 and a socket unit 13 are provided at two opposite lateral sides of the electrical adapter 1 at the bottom. By means of fastening the plug unit 12 of one electrical adapter 1 to the socket unit 13 of another, a plurality 10 of electrical adapters 1 are connected in series, and a power cable 17 can be connected to the socket unit 13 of the first piece of the series of electrical adapters 1 (see Figure 3). The electrical adapter 1 further comprises a longitudinal coupling groove 15 and a pair of longitudinal coupling plates 141 respectively disposed at 15 its two lateral sides, and a through hole 151 pierced through one corner thereof and intersected with the longitudinal coupling groove 15. The longitudinal coupling plates 141 are separated by a gap 143, having a respective through hole 142 corresponding to the through hole 151, and a respective hooked flange 14. When 20 two electrical adapters 1 are connected together, the longitudinal coupling plates 141 and their hooked flanges 14 of one electrical adapter 1 are forced into engagement with the longitudinal

○ coupling groove 15 of the other, and a screw bolt 16 is fastened to the through holes 151;142 to fix the two electrical adapters 1 together. A second sliding cover 2 is provided inside the electrical adapter 1, and adapted to close the second power contact blade insertion holes 113. The second sliding cover 2 has two pockets 21. Two spring elements 222 are respectively mounted on a respective stop rod 1114 inside the electrical adapter 1, and partially inserted into the pockets 21. The spring elements 222 impart a downward pressure to the second sliding cover 2, causing it to close the second power contact blade insertion holes 113. The second sliding cover 2 has a top block 22 with a sloping guide face 221 at its front side in the middle. When an electrical plug of South Africa specifications is inserted into the second power contact blade insertion holes 113 and the corresponding grounding prong insertion hole 1111, the grounding prong of the electrical plug is perpendicularly forced against the sloping guide face 221 of the second sliding cover 2, thereby causing the second sliding cover 2 to be lifted, for permitting the electrical plug to be inserted into position.

20            Figures 5-A and 5-B show an electrical adapter 1 made according to a second embodiment of the present invention. According to this embodiment, the electrical circuit of the

○ electrical adapter 1 is comprised of a voltage regulator 154, a voltmeter 1541, a voltage stabilizer 152, a power switch 152, and a surge absorber 153.

Figures 6, 7 and 7-A show an electrical adapter 4 according to a third embodiment of the present invention. An electrical adapter 4 according to this embodiment is adapted to receive an electrical plug of German specification 46. The electrical adapter 4 comprises a recessed chamber 41 at its front side for receiving the electrical plug of German specification 46, two through holes 43 disposed in the recessed chamber 41 and adapted to receive the two blades 461 of the electrical plug of German specification 46, two electrically insulative locating rods 42 raised its back side and adapted for inserting into for example the second power contact blade insertion holes 113 of the electrical adapter 1 of the first embodiment shown in Figure 1, two grounding prong mounting holes 44 pierced through the recessed chamber 41, and a grounding prong 45 fastened to the grounding prong mounting holes 44. The grounding prong 45 comprises a prong body 451 adapted to insert into one grounding prong insertion hole 1115 in the grounding prong insertion hole 111 of the electrical adapter 1 of the first embodiment shown in Figure 1, and two mounting legs 451 respectively mounted in the grounding prong mounting holes 44.

○ When the electrical plug of German specification 46 is fastened to the electrical adapter 4, the mounting legs 451 of the grounding prong 45 are respectively inserted into two grooved grounding terminals 462 of the electrical plug of German specification 46.

5 Referring to Figure 7-B the grounding prong 47 comprises a prong body 47 adapted for fastening to one grounding prong insertion hole of the electrical adapter 1 shown in Figure 1, and a rectangular mounting leg 472 adapted for fastening to one grounding prong mounting hole 44 of the electrical adapter 4.

10 Figures from 7-C to 7-H show different alternate forms of the electrical adapter 4. As indicated, the through holes 43 and the electrically insulative locating rods 42 may be variously arranged to fit different electrical plugs.

Figures 8, 8-B and 8-C show an electrical adapter 1  
15 according to a fourth embodiment of the present invention. According to this embodiment, the electrical adapter 1 has a track 19 at its back side adapted to hold a plug member 18. The plug member 18 has two rails 181 at two opposite sides adapted for inserting into the track 19. When the plug member 18 is inserted  
20 into the track 19, its blades and grounding prong are respectively forced into contact with respective power contacts 1121 and grounding contact 1113 of the electrical adapter 1. The plug

member 18 may be variously embodied to fit different specifications (see Figure 9). When the plug member 18 is removed from the electrical adapter 1, a cover plate 144 may be fastened to the track 19 to fill up the gap. Further, the plug unit 12 is retractable. Two tracks 122;132 are provided at two opposite lateral sides of the electrical adapter 1 corresponding to the plug unit 12 and socket unit 13. Two sliding cover plates 123;133 are provided for fastening to the tracks 122;132 to close the plug unit 12 and the socket unit 13. Of course, when to insert the sliding cover plate 123 into the track 122, the plug unit 12 must be pushed back to the inside of the electrical adapter 1.

According to a fifth embodiment according to the present invention, the back board, referenced by 182 (see Figure 8-A), has two rails 1821 at two opposite sides adapted for inserting into the track 19 of the electrical adapter 1 (see also Figure 8), a plurality of cylindrical wire holders 1822 defining a respective wire hole 1823 adapted to receive the hot wire, the neutral wire and the grounding wire respectively, and a plurality of tightening up screws 1824 respectively fastened to the cylindrical wire holders 1822 to fix the hot wire, the neutral wire and the grounding wire in place.

Figures 10, 11 and 12 show an electrical adapter 1



according to a sixth embodiment of the present invention.

5 According to this embodiment, electrical socket members 5, 51 and 52 of a particular specification are integral with the electrical adapter 1 at the back side.

10 Figures 13 and 14 show an electrical adapter 1 according to a seventh embodiment of the present invention. According to this embodiment, the electrical adapter 1 comprises module jacks 53;533 at its front side and one lateral side, and module plugs 532;534 at its back plate 5341 an second lateral side. By plugging one module plug 532 or 534 of one electrical adapter 1 to one module jack 53 or 533 of another, a plurality of electrical adapters 1 according to the seventh embodiment of the present invention are connected in series. Through the module jacks 53;533 and module plugs 532;534, the electrical adapter 1 is used for connecting telephone lines 531.

20 Figures 15 and 16 show an electrical adapter according to a eighth embodiment of the present invention. According to this embodiment, the electrical adapter 1 comprises female coaxial cable connectors 54;542 at its front side and one lateral side, and male coaxial cable connectors 544,543 at its back plate 5441 an second lateral side. By plugging male coaxial cable connector 544 or 543 of one electrical adapter 1 to one female coaxial cable

connector 54 or 542 of another, a plurality of electrical adapters 1 according to the eighth embodiment of the present invention are connected in series. Through the male coaxial cable connectors 544; 543 and female coaxial cable connectors 54;542, the electrical adapter 1 is used for connecting coaxial cables 531 for signal transmission.

Figure 17 shows an electrical adapter according to a ninth embodiment of the present invention. According to this embodiment, the electrical adapter 6 comprises a base plate 61, a face panel 62 covered on the base plate 61, a sets of power contact frames 611 and grounding contact frame 612, a power switch 65, a surge absorber 66, a recessed chamber 63 with power contact blades 631 and a socket 64 at two opposite ends.

Figure 18 shows a face panel with insertion holes for electrical plugs of different specifications. Figure 18-A shows a insertion hole-application country comparison table according to the present invention.

**CLAIMS:-**

1. An adapter comprising an adapter body, said  
adapter body comprising a plug unit at a first lateral  
5 side thereof and a socket unit at a second lateral  
side thereof, the size of said plug unit fitting that  
of said socket unit so that a plurality of adapters  
can be connected in series by plugging the plug unit  
of one adapter into the socket unit of another, a  
10 longitudinal coupling groove at its first lateral side  
and a pair of longitudinal coupling plates at its  
second lateral side, a tie hole pierced through one  
corner thereof and intersected with longitudinal  
coupling groove, said longitudinal coupling plates  
15 having a respective through hole, said longitudinal  
coupling plates and said longitudinal coupling groove  
being so arranged that the longitudinal coupling  
plates of one adapter are fitted into the longitudinal  
coupling groove of another when a plurality of  
20 adapters are connected in series, permitting the  
through holes of the longitudinal coupling plates of  
one adapter to be fastened to the tie hole of another  
adapter by a fastening element.

25 2. The adapter of claim 1 wherein said adapter does  
not include longitudinally aligned insertion holes.

3. The adapter of claim 1 or claim 2, wherein said  
adapter body comprises two electrical sockets at a  
30 back side thereof.

4. The adapter of claim 1 or claim 2, wherein said  
plug unit and said socket unit respectively comprise  
module plugs and module jacks for a telephone line and  
35 wherein said adapter body comprises two module jacks  
adapted for receiving module plugs of telephone lines.

5. The adapter of claim 1 or claim 2, wherein said plug unit and said socket unit respectively comprise female and male parts of a coaxial cable connector and wherein said adapter body comprises two female coaxial cable connectors adapted for receiving male coaxial connectors of electrical signal lines.



Application No: GB 0200741.7  
Claims searched: 1-5

Examiner: Graham Russell  
Date of search: 4 March 2002

## Patents Act 1977 Search Report under Section 17

### Databases searched:

UK Patent Office collections, including GB, EP, WO & US patent specifications, in:

UK Cl (Ed.T):

Int Cl (Ed.7): H01R 27/00

Other: Online: EPODOC

### Documents considered to be relevant:

Category	Identity of document and relevant passage	Relevant to claims
	NONE	

X	Document indicating lack of novelty or inventive step	A	Document indicating technological background and/or state of the art.
Y	Document indicating lack of inventive step if combined with one or more other documents of same category.	P	Document published on or after the declared priority date but before the filing date of this invention.
&	Member of the same patent family	E	Patent document published on or after, but with priority date earlier than, the filing date of this application.