

J. J. SHEA.
SURGICAL SALINE INFUSION APPARATUS.
APPLICATION FILED JAN. 16, 1904.

2 SHEETS—SHEET 1.

Fig. 1.

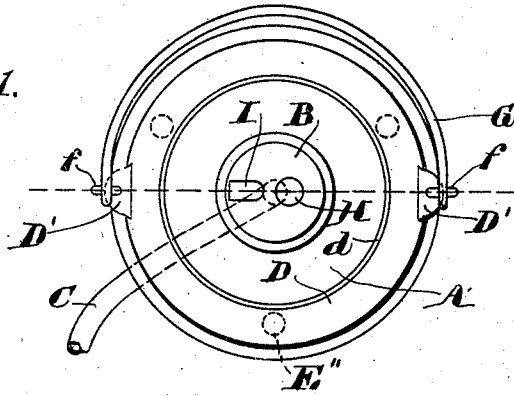
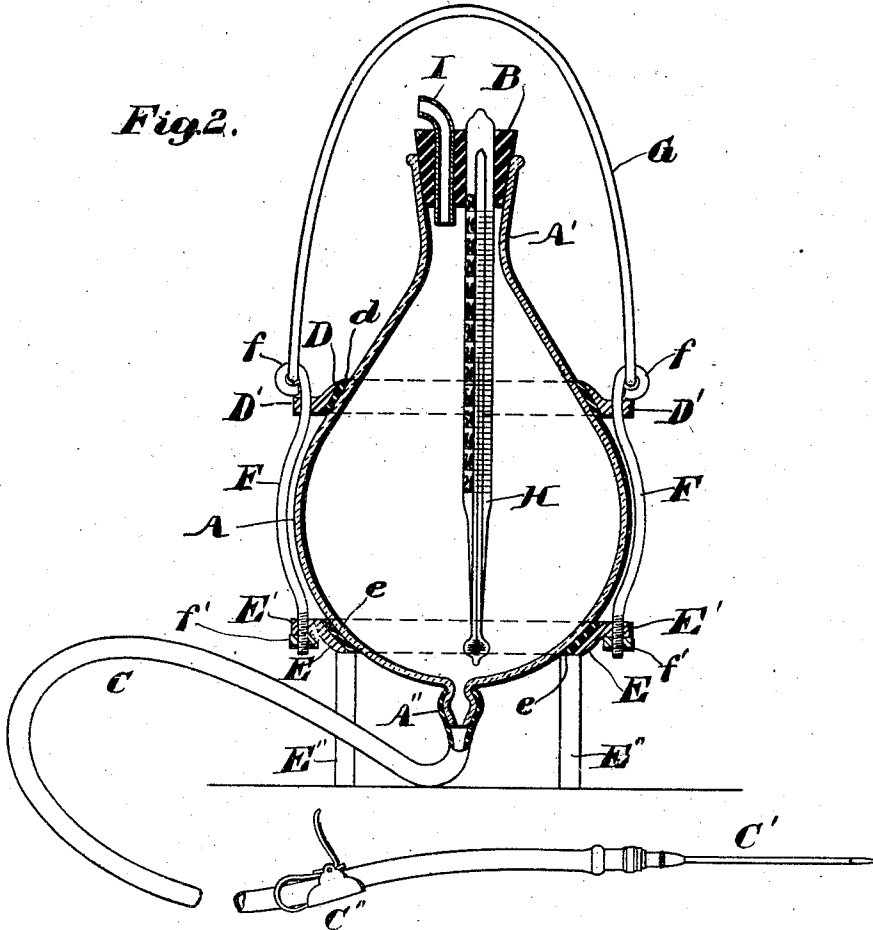

Fig. 2.



Witnesses:
 Frank A. Smith.
 George H. Buckingham.

Inventor:
 John J. Shea,
 by *Alfred Andrew Atty.*

J. J. SHEA.
SURGICAL SALINE INFUSION APPARATUS.

APPLICATION FILED JAN. 16, 1904.

2 SHEETS—SHEET 2.

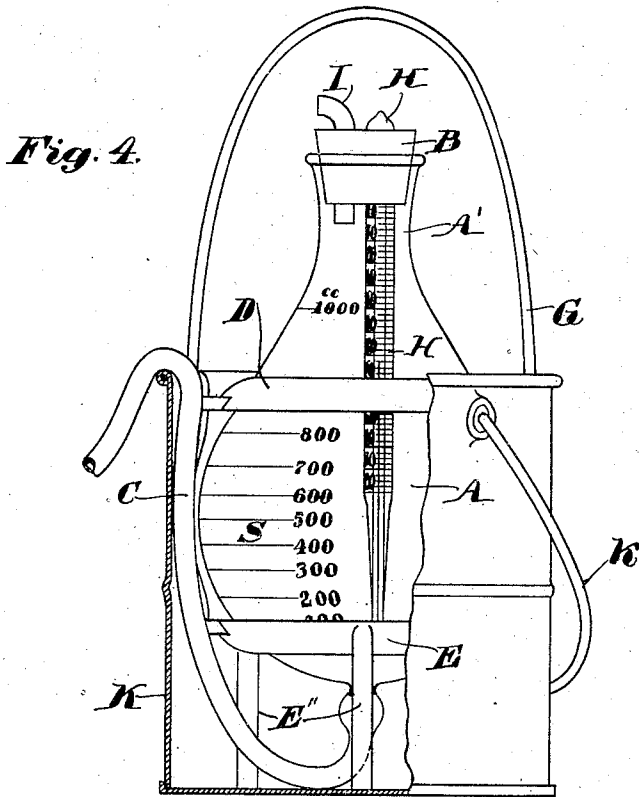
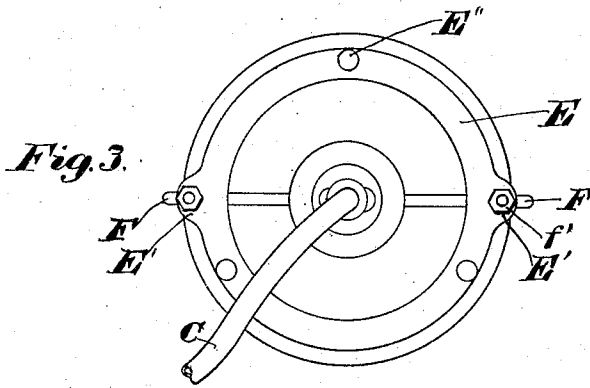

Witnesses:

Frank A. Smith
George H. Buckingham

Inventor:

John J. Shea,
by Allan Andrew Atty.

UNITED STATES PATENT OFFICE.

JOHN J. SHEA, OF BEVERLY, MASSACHUSETTS.

SURGICAL SALINE-INFUSION APPARATUS.

SPECIFICATION forming part of Letters Patent No. 785,524, dated March 21, 1905.

Application filed January 16, 1904. Serial No. 189,253.

To all whom it may concern:

Be it known that I, JOHN J. SHEA, a citizen of the United States, and a resident of Beverly, in the county of Essex and State of Massachusetts, have invented certain new and useful Improvements in Saline-Infusion and Irrigating Flasks for Medical and Surgical Purposes, of which the following is a specification.

This invention relates to improvement in saline-infusion and irrigating flasks for the use of physicians and surgeons for the purpose of making subcutaneous injections as well as for irrigating purposes, and it is carried out as follows, reference being had to the accompanying drawings, wherein—

Figure 1 is a top plan view of the invention. Fig. 2 is a central longitudinal section on the line 2 2 shown in Fig. 1. Fig. 3 is a bottom plan view; and Fig. 4 is a side elevation showing the flask inserted in a vessel or receptacle, as will hereinafter be more fully described.

Similar letters refer to similar parts wherever they occur on the different parts of the drawings.

The device consists of a glass reservoir A of substantially spherical form and terminating at its upper end as a neck A', adapted to be closed by a suitable rubber cork or stopper B, as shown.

The flask or reservoir A is provided at its bottom with a preferably nipple-shaped outlet A'', to which is suitably connected a rubber tube C, having attached to its end a subcutaneous needle C', such as used by physicians and surgeons in making saline transfusions.

C'' is a suitable cut-off on the tube C for arresting or regulating the flow of the liquid contained in the reservoir A at any desired stage of the operation.

The glass reservoir A is attached to a frame or stand composed of upper and lower metal rings D E, between which and the flask are interposed, preferably, rubber packing-rings *d e* to prevent the flask from breaking or cracking. The said rings D E are detachably connected to the glass reservoir A by means of metal rods F F going through perforated

ears D' E' on the respective rings D E. The upper end of each rod F is provided with an eye *f*, to which is pivotally connected a bail-wire G, as shown. The lower end of each rod F is screw-threaded and passes loosely through the perforated eye E' in the lower ring E and is secured by means of an adjustable nut *f''*, by which arrangement the rings D E are attached to the glass reservoir A, as shown. In one piece with the lower ring E or attached thereto are a series of downwardly-projecting legs E'' E''' E'', serving as a stand or support for the flask when placed upon a desk, shelf, table, &c., at a proper height above the patient when the device is in use.

The bail G serves as a convenient handle for carrying the flask, and it also serves as a means for suspending the flask at a proper height above the person for irrigating or injecting purposes.

In a perforation in the stopper B is inserted a suitable thermometer H, the lower end of which extends to near the bottom of the flask A, as shown, for the purpose of ascertaining the temperature of the liquid contents of the flask preparatory to ejecting the saline solution therefrom.

I is an air-inlet tube inserted through a perforation in the stopper B to allow air to enter the flask to compensate for the displacement of the liquid when drawn from it.

In practice I mark on the flask A a scale S, preferably marked in cubic centimeters, as shown in Fig. 4, for the purpose of measuring the contents of the flask and the amount of liquid discharged at any time.

In connection with the device as hereinabove described I use a suitable can or receptacle K, having a bail *k*, (shown in Fig. 4,) adapted to serve as a vessel in which to boil the solution for the purpose of sterilizing it, as well to hold the flask before or after the solution is placed in the latter, as well as for reheating the solution contained in the flask, by immersing the latter in liquid contained in the vessel K and heating the contents of said vessel.

In using this my improved saline-solution

and irrigating flask I put about a quart of water in the vessel K and boil it, or a similar quantity of boiling water is put into said vessel, and a sufficient quantity of salt is added to make a normal salt solution. Then the liquid is again boiled, strained through absorbent cotton or filter-paper into the flask A, the stopper B, containing the thermometer, being removed from the flask during the filling operation, after which the stopper is put in place at the neck of the flask. The now filled flask is put into the vessel K and put away ready for an emergency. When it is desired to use the sterilized solution, water is put in the vessel K, containing the flask and its contents, which is then brought to the desired temperature, indicated by the thermometer in the flask. The flask is then removed from the vessel K and either hung up or supported on a shelf, &c., at a suitable height above the patient. The needle C' is then inserted under the skin of the patient and a proper quantity of the solution allowed to flow.

The device may also be used for irrigating purposes in a manner like that of a gravity-bag.

Having thus fully described the nature, con-

struction, and operation of my invention, I wish to secure by Letters Patent and claim—

1. In a device of the character described, a transparent receptacle having an open neck at its upper end and a discharge-nozzle at its lower end, a plurality of holding-rings surrounding said receptacle, supports carried by the lower of said rings, clamping-rods extending through said rings, take-up nuts for said rods and a carrying means suitably connected with said rings.

2. In a device of the character described, a transparent receptacle having an open neck at its upper end and a discharge-nozzle at its lower end, a plurality of holding-rings surrounding said receptacle, supports carried by the lower of said rings, clamping-rings extending through said rings and provided at their upper ends with eyes, take-up nuts carried by the lower end of said rods, and a bail connected to the eyes of the rods.

In testimony whereof I have affixed my signature in presence of two witnesses.

JOHN J. SHEA.

Witnesses:

ALBAN ANDRÉN,
SAMUEL F. WHITE.