



US00D981588S

(12) **United States Design Patent**
Mantovan et al.

(10) **Patent No.:** **US D981,588 S**

(45) **Date of Patent:** **** Mar. 21, 2023**

(54) **DISINFECTATION EQUIPMENT FOR PREMISES**

(71) Applicant: **JONIX S.R.L.**, Tribano (IT)

(72) Inventors: **Mauro Mantovan**, Tribano (IT);
Antonio Cecchi, Tribano (IT)

(73) Assignee: **JONIX S.P.A.**, Tibano (IT)

(**) Term: **15 Years**

(21) Appl. No.: **35/513,144**

(22) Filed: **Jun. 15, 2021**

(80) **Hague Agreement Data**

Int. Filing Date: **Jun. 15, 2021**

Int. Reg. No.: **DM/214887**

Int. Reg. Date: **Jun. 15, 2021**

Int. Reg. Pub. Date: **Dec. 17, 2021**

(30) **Foreign Application Priority Data**

Dec. 15, 2020 (EM) 008322481

(51) **LOC (14) Cl.** **24-02**

(52) **U.S. Cl.**
USPC **D24/217**

(58) **Field of Classification Search**
USPC D24/217, 231; D26/37; D23/364, 366;
D32/1
CPC A61M 39/20; A61M 35/006; A61L 9/22;
B03C 3/38
See application file for complete search history.

(56) **References Cited**

U.S. PATENT DOCUMENTS

D581,058 S * 11/2008 Elkerbout D24/217
7,540,681 B2 * 6/2009 Cybulski A61M 35/006
401/133

D631,620 S * 1/2011 Choi D32/1
D652,529 S * 1/2012 Eum D24/217
D868,992 S * 12/2019 Ma D24/217
10,493,261 B2 * 12/2019 Solomon A61M 39/20
D881,406 S * 4/2020 Kim D24/217
D893,045 S * 8/2020 Tang D24/217
D901,713 S * 11/2020 Nicoll D24/217
D919,109 S * 5/2021 Ou Yang D24/217
D925,762 S * 7/2021 LaPorte D24/217
D937,399 S * 11/2021 Sarkar D23/366
D938,610 S * 12/2021 Ou Yang D24/217
D956,291 S * 6/2022 Xu D26/37
D961,112 S * 8/2022 Krömker D24/217
D966,481 S * 10/2022 Zhang D23/364
D967,570 S * 10/2022 Maw D32/1
2022/0054670 A1 * 2/2022 Mantovan A61L 9/22
2022/0054700 A1 * 2/2022 Mantovan B03C 3/38

* cited by examiner

Primary Examiner — Rhea Shields

(74) *Attorney, Agent, or Firm* — Leason Ellis LLP

(57) **CLAIM**

The ornamental design for a disinfection equipment for premises, as shown and described.

DESCRIPTION

1. Disinfection equipment for premises

- 1.1 : Perspective
- 1.2 : Front elevation view
- 1.3 : Left side elevation view
- 1.4 : Rear elevation view
- 1.5 : Right side elevation view
- 1.6 : Bottom plan view
- 1.7 : Top plan view

The broken line shown is for the purpose of illustrating portions of the disinfection equipment for premises and forms no part of the claimed design.

1 Claim, 7 Drawing Sheets

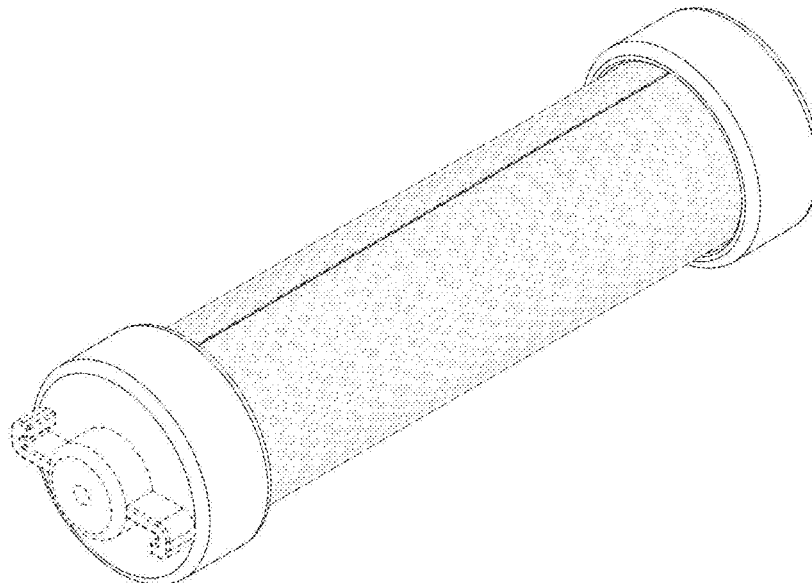

1.1

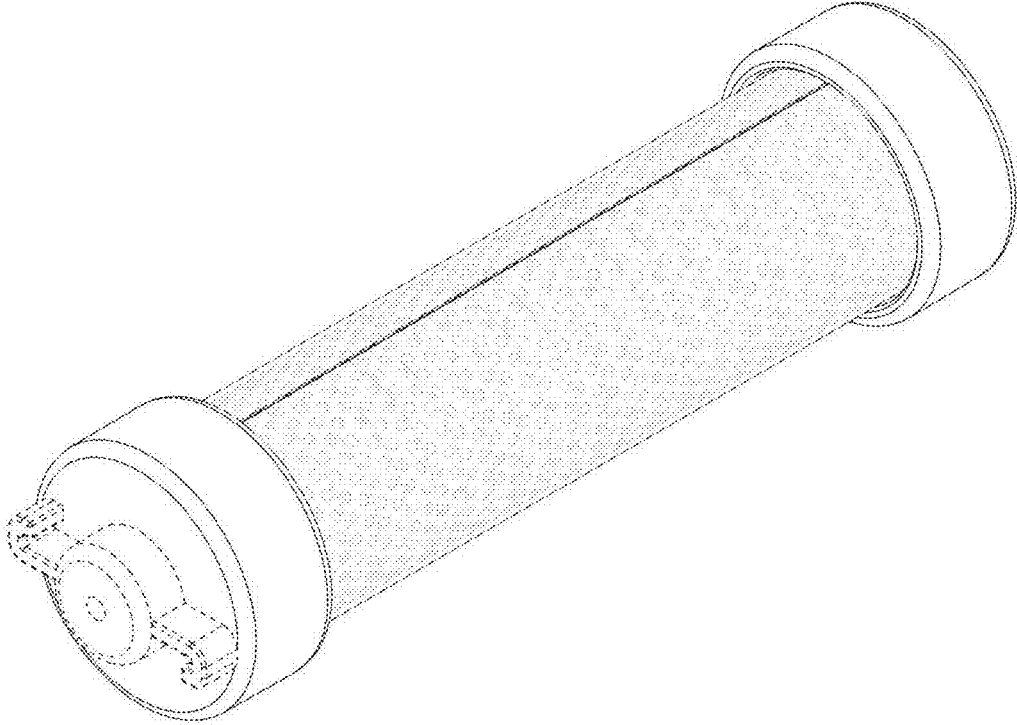

1.2

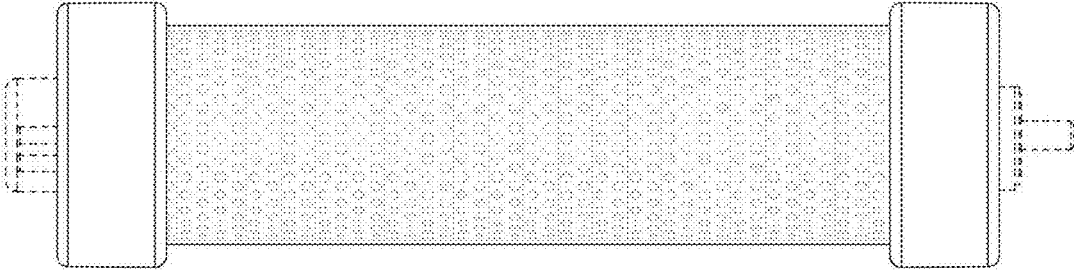

1.3

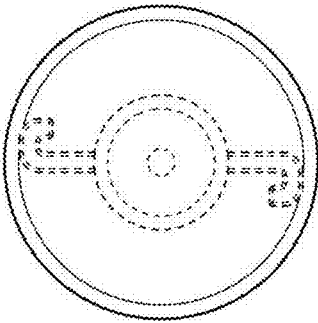

1.4

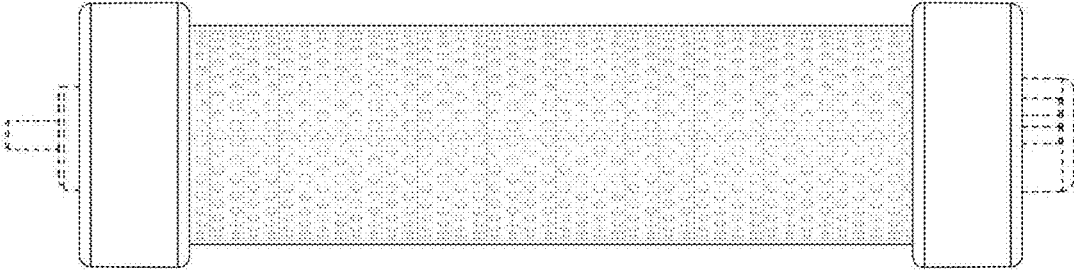

1.5

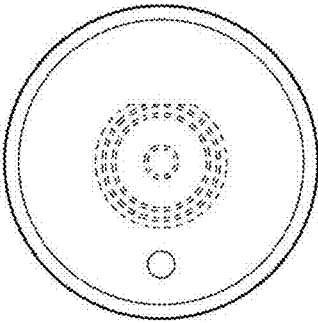

1.6

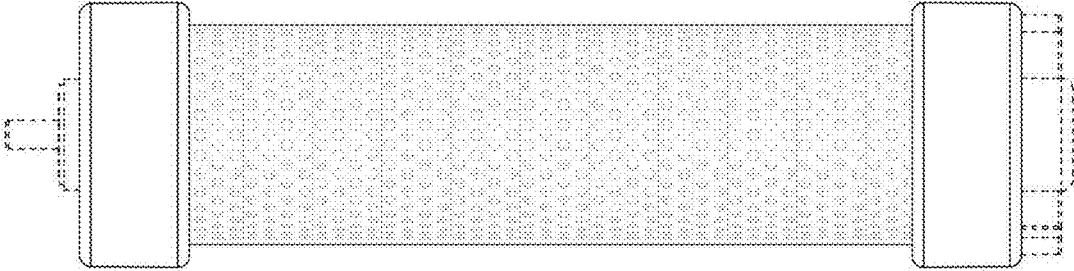

1.7

