

(43) Date of A Publication 12.07.1995

(21) Application No 9500406.5

(22) Date of Filing 10.01.1995

(30) Priority Data

(31) 9400392

(32) 11.01.1994

(33) GB

(71) Applicant(s)

Keith Ian Chester
10 Leland PLace, Kirkhill, MORPETH,
Northumberland, NE61 2AN, United Kingdom

(72) Inventor(s)

Keith Ian Chester

(74) Agent and/or Address for Service

Urquhart-Dykes & Lord
St Nicholas Chambers, Amen Corner,
NEWCASTLE-UPON-TYNE, NE1 1PE, United Kingdom

(51) INT CL⁶

F16C 17/03 17/06

(52) UK CL (Edition N)

F2A AD48 A6D1 A6E2

(56) Documents Cited

GB 2268549 A EP 0083987 A2 US 4815865 A

US 4636095 A

(58) Field of Search

UK CL (Edition N) F2A

INT CL⁶ F16C 17/00 17/03 17/06 32/06

(54) Bearing assembly with pads

(57) A bearing assembly for supporting a rotatable shaft comprises a number of bearing pads 40 supported in a housing 41 and the mutually engaging surfaces of each bearing pad and the housing are two surfaces of closely similar shape. These surfaces diverge in a first direction circumferential to the shaft and are each either rectilinear or only very slightly curved in a second direction at right angles to the first direction. The differences between the two surfaces give a contact angle between the surfaces of less than three degrees (preferably less than one degree) in the first direction and of less than one degree (preferably less than 0.1 degree) in the second direction.

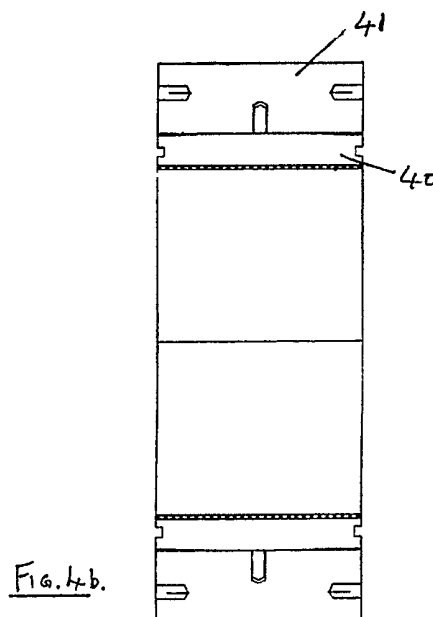
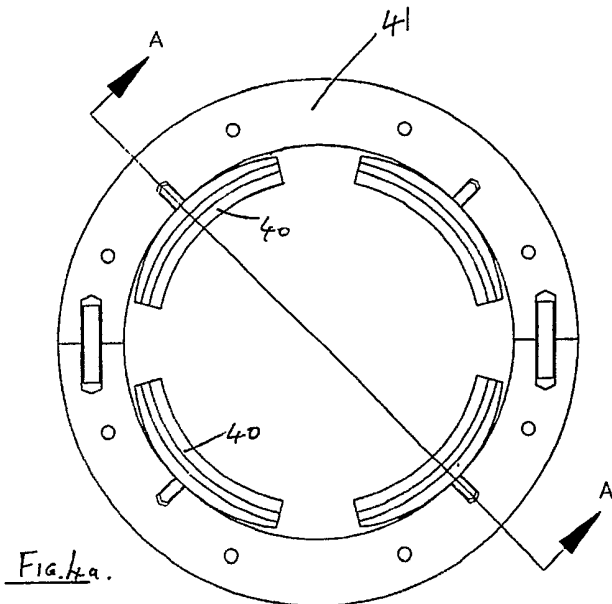

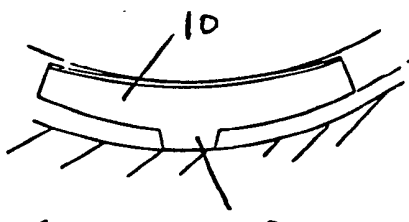

Fig. 1 a.

10a

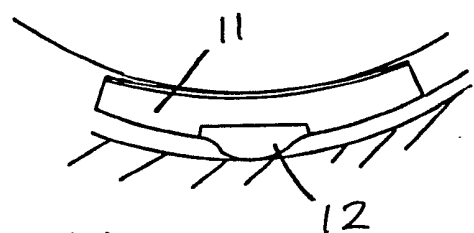

Fig. 1 b.

12

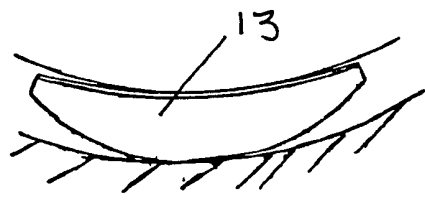

Fig. 1 c

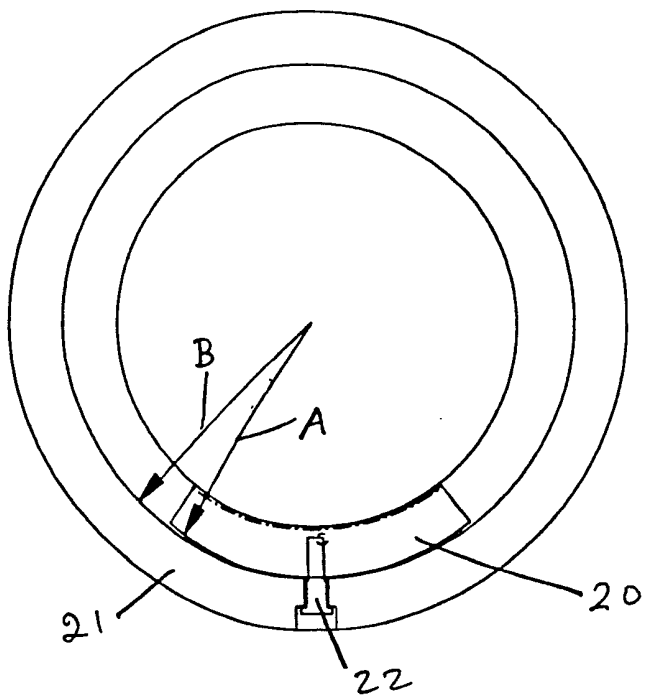

Fig. 2 a.

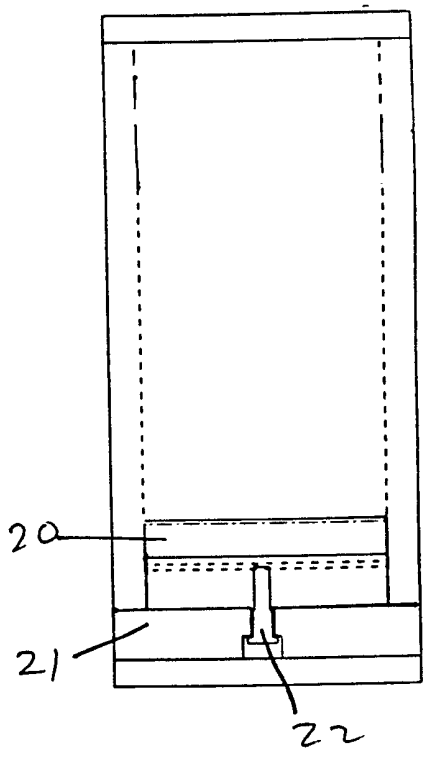
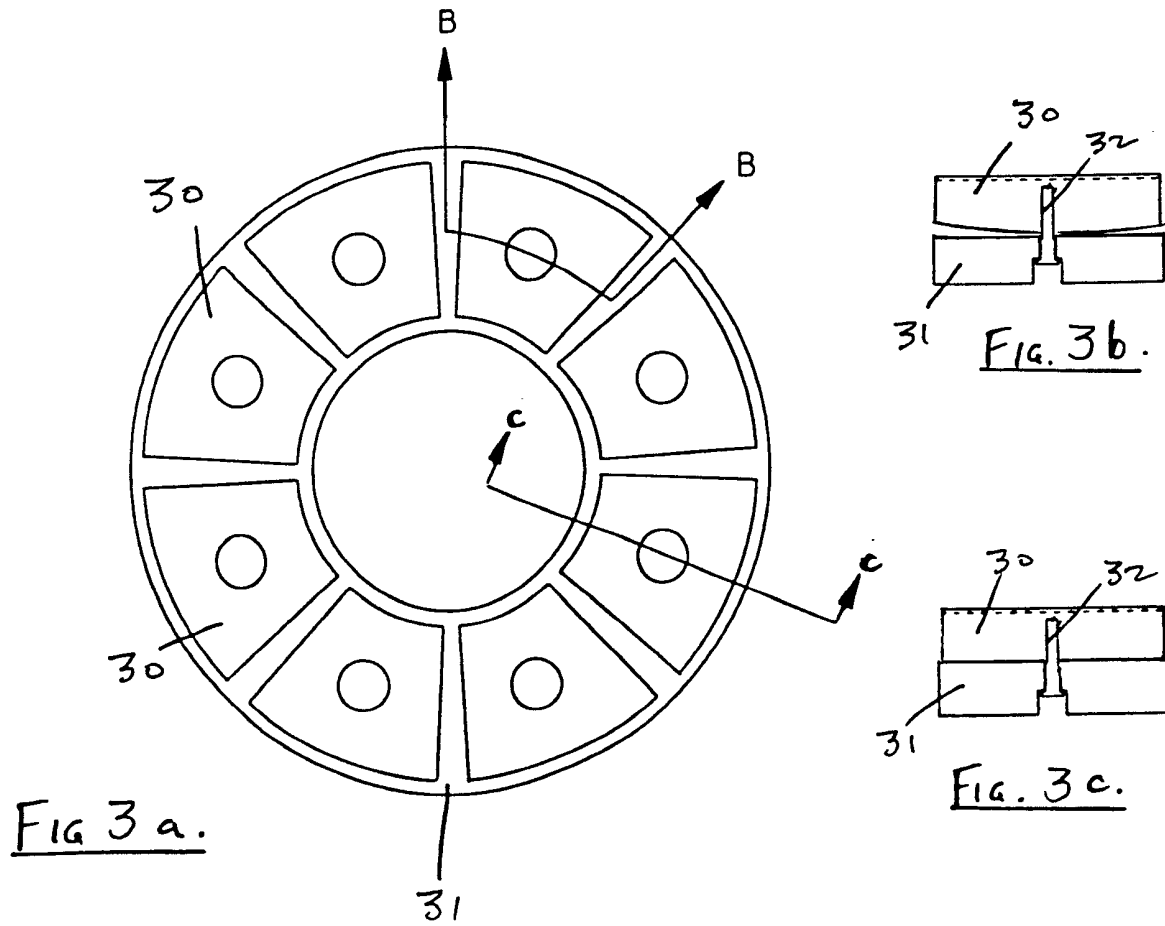

Fig. 2 b.



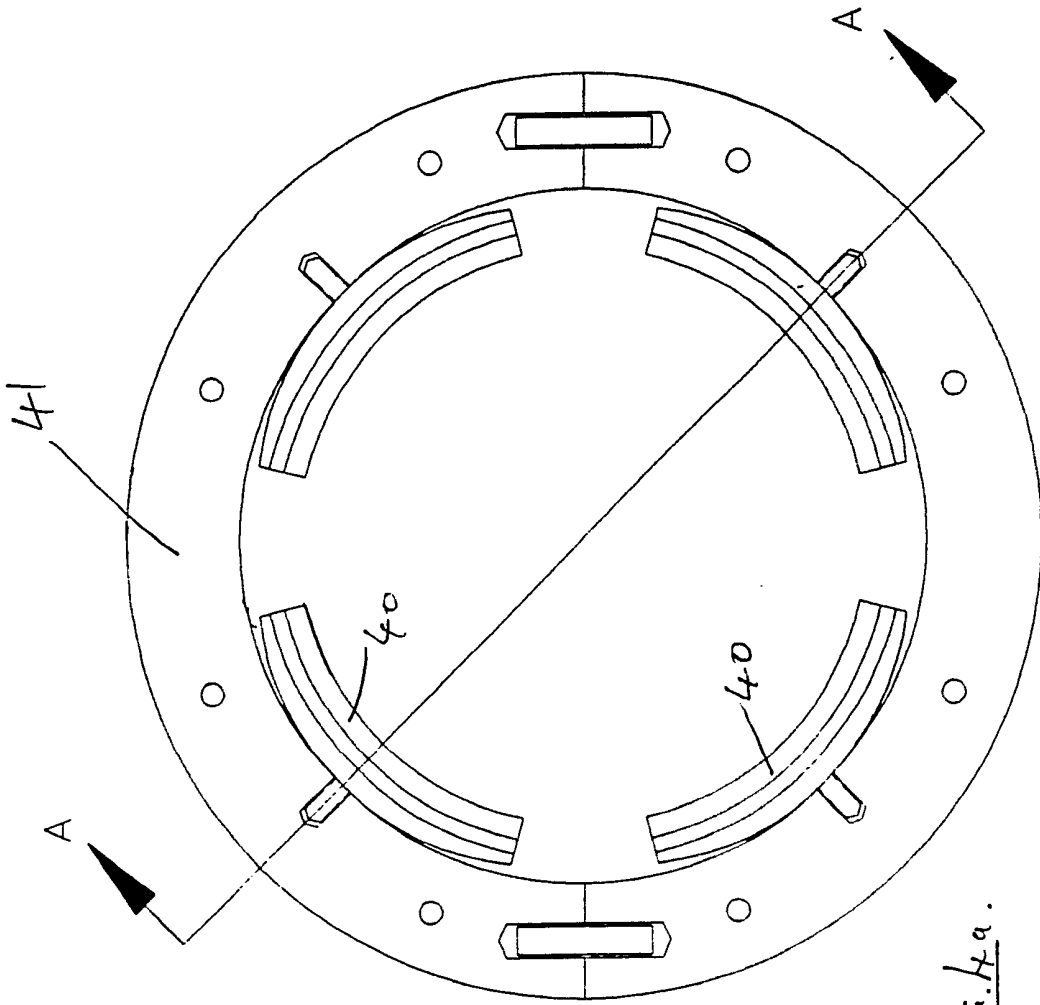

FIG. 4a.

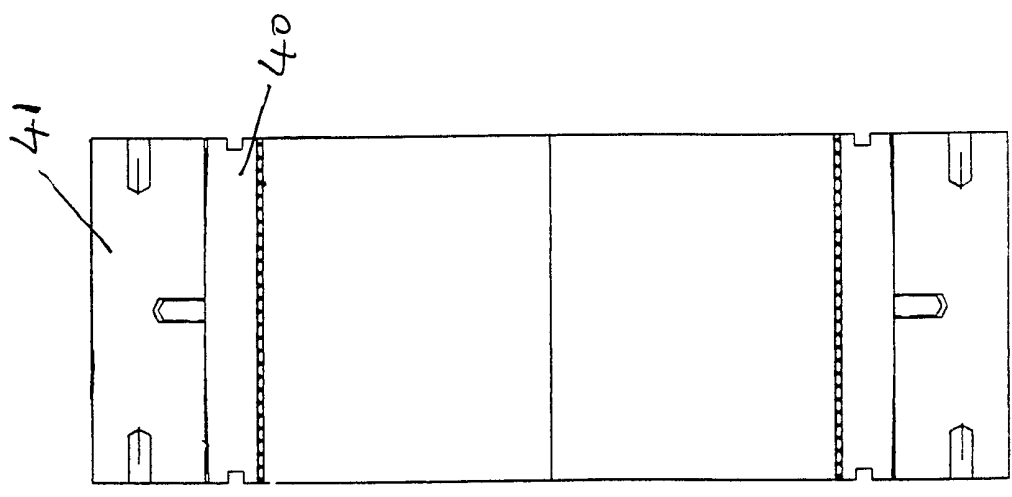

FIG. 4b.

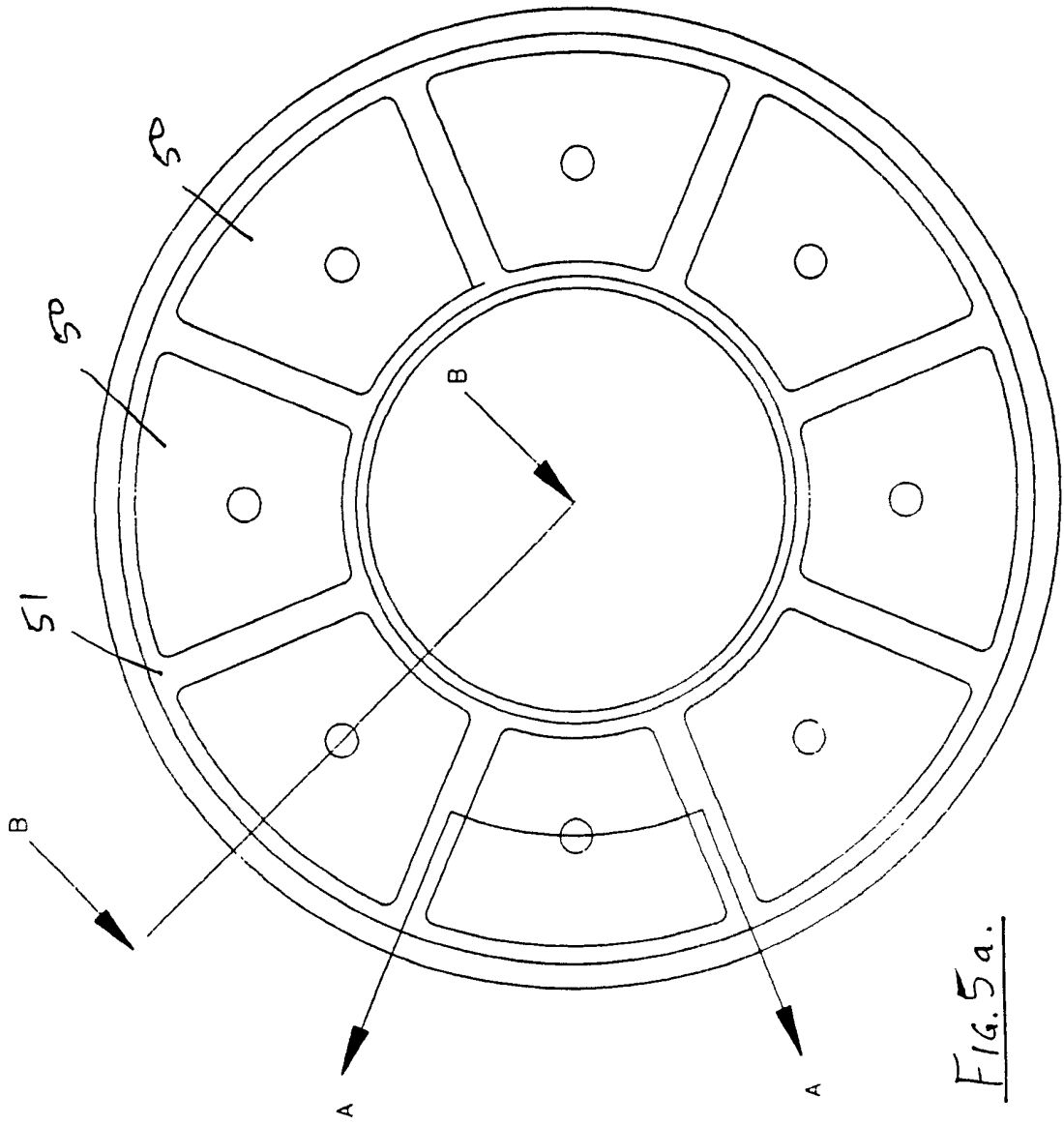

FIG. 5a.

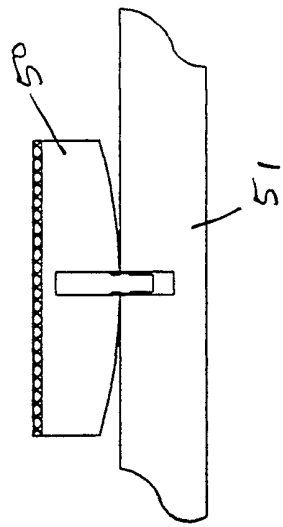

FIG. 5b.

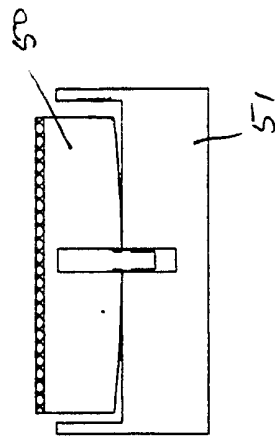

FIG. 5c.

Improved Bearing Assembly

The present invention is concerned with bearing assemblies of both the journal and thrust bearing types and is an improved bearing assembly.

5 Bearing assemblies are used in a very wide range of applications to afford radial and/or axial support for rotating shafts or spindles. While unitary journals or thrust rings are widely used, there are considerable advantages in construct-

10 ing a bearing assembly from several discrete pads, which individually abut the shaft or thrust collar and are able to rock about a pivot to provide a wedge-shaped clearance between each pad and the rotating member. The introduction of oil

15 into the bearing assembly by suitable means allows the development of a hydrodynamic film of oil between the bearing element and the rotating shaft or collar. This working film of oil prevents direct contact between the shaft or collar and

20 the surface of the bearing element, which may be coated with an anti-friction material such

as white metal.

The majority of prior bearing pad assemblies have depended upon line contact between the pad and the adjacent housing and the pads have typically
5 been designed to rock by some 5 to 10 degrees of arc about the line of contact. This considerable freedom to rock allows adequate freedom for adjustment of the pad position and makes only moderate demands on the accuracy required of the relevant components.

10 Figure 1 of the accompanying drawings illustrates, in sectional view transverse to the axis of the rotating shaft, three conventional forms of bearing pad mounting. In Fig. 1a, a journal pad 10 is shown supported on an integral bar or ridge pivot
15 10a. The pad 11 shown in Fig. 1b is supported upon a bar pivot 12 formed as an insert of hardened metal incorporated in the pad.

Fig. 1c illustrates a journal pad 13 with a curved back. The difference in curvature between
20 the back of the pad and the adjacent housing allows some 5 to 10 degrees of rocking about the line of contact between these components, which line moves to a relatively small extent around the curved surface of the housing as the bearing pad
25 rocks.

During rotation of a shaft supported by a bearing assembly of the foregoing types, the formation of the oil film in the wedge between bearing pad and shaft is accompanied by the rocking of the pad. A stable condition is reached where the position of the shaft and the loads upon it are in balance with the forces produced by the various oil film pressures on the bearing elements.

The only constraint on the position of the shaft arises from the oil pressure generated within the clearance between the shaft and the operating surfaces of the bearing elements. The shaft may be subject to variations in its load, which in turn results in changes in the thickness of the oil films and in the pressure profiles and the position of the shaft. Although these changes are usually small, they can result in changes in the pad position by rocking about its line of pivoted contact with the surface of the housing. In the case of some prior bearing assemblies, this movement of the pad can adversely affect bearing performance, where instability can result. Factors such as the risk of such instability may unduly influence the machine designer's choice of bearing type, for example between plain sleeve

bearings and journal pad bearings.

Bearings operating at high rotational speeds, which are most likely to suffer instability problems, also tend to be fairly lightly loaded, which light
5 loading contributes to the tendency of the shaft to orbit within the available bearing space. Bearings likely to suffer such problems are usually specifically designed to overcome the potential problems because there is no alternative solution
10 generally available. Attempts to counter the problem by controlling the external damping or modifying the machine performance rarely succeed.

Against the foregoing background, it is an object of the present invention to provide an
15 improved bearing assembly, whereby the ability of the bearing pads to rock quickly about their lines of contact with the housing is restricted and the risk of potential instability may be reduced to levels which are acceptable.

20 The improved bearing assembly according to the present invention, for supporting a rotatable shaft, comprises a plurality of bearing pads supported by a surrounding housing, the mutually engaging surfaces of each bearing pad and the housing being
25 two surfaces of closely similar shape, which surfaces

diverge in a first direction generally circumferential to the shaft and are each either rectilinear or only very slightly curved in a second direction generally at right angles to the first direction, the differences between the surfaces in said
5 respective directions being such that the contact angle between the surfaces is less than three degrees of arc in said first direction and less than one degree of arc in said second direction.

10 The close matching of the surface of the bearing pad to that of the adjacent housing enables a thin wedge of oil to be trapped between these components. This wedge of oil effectively damps quick rocking of the bearing pad about its line
15 of contact with the housing, by means of the considerable resistance generated by the oil under squeeze film conditions. However, normal rocking of the bearing pad at low speeds is not restricted so there is no material effect on the normal formation
20 of a hydrodynamic oil wedge.

The same benefits and considerations apply also to thrust pad bearing assemblies as apply to journal pad bearing assemblies.

25 The contact angle between the interengaging surfaces of the bearing pad and the housing is

preferably less than one degree of arc in the circumferential direction of the shaft and less than 0.2 degree of arc, more preferably less than 0.1 degree, in the second direction. Preferably
5 the ratio of these two angles in these respective directions is at least 5:1 and more preferably at least 10:1. As a result of these very small angles of contact, under elastic loading conditions the area of contact is in the form of an ellipse
10 with a high aspect ratio, typically of the order of 10:1.

In one form of the present invention, the two surfaces are both rectilinear in the second direction (which is parallel to the axis of the shaft in the case of a journal bearing and radial
15 to that axis in the case of a thrust bearing). That is, they are two generally cylindrical surfaces. The difference between the radii of curvature of such generally cylindrical surfaces should be
20 small, and preferably is less than one per cent. More preferably, the difference is less than 0.1 per cent. The maximum angular rocking movement of the pad may as a result be as little as one degree of arc and typically about 0.25 degrees.

25 The pads may advantageously be held in position

within the housing by locating pins, for example projecting from the housing into sockets in the pads. The extent to which the pins project should be such that the pads are prevented from movement
5 around the shaft but are not supported or restrained by the pins.

The invention will now be further described with reference to the accompanying drawings, which illustrate, by way of example only, four embodiments
10 of the bearing assembly according to the present invention and wherein:-

Figs. 2a and 2b show a first embodiment of journal bearing assembly;

Figs. 3a, 3b and 3c show a first
15 embodiment of thrust bearing assembly;

Figs. 4a and 4b show a second embodiment of journal bearing assembly;
and

Figs. 5a, 5b and 5c show a second
20 embodiment of thrust bearing assembly.

Fig. 2a is a transverse sectional view of the first journal bearing assembly and Fig. 2b is a corresponding sectional view in a plane parallel to the axis of the shaft. The bearing is assembled
25 from four bearing pads 20, only one of which is

shown, each secured in a housing 21 by a pin 22 which prevents the pad from being displaced relative to the housing but does not support the pad. The outer surface of the bearing pad 20, of which the radius is shown by the reference letter A, and the inner surface of the housing (radius B), are both of cylindrical form. Radius A is approximately 0.05 per cent less than radius B. The line of contact of the two cylindrical surfaces is a straight line parallel to the axis of the shaft, about which line the pad 20 may rock by a very small amount.

Fig. 3a is a plan view, in the direction of the axis of the shaft, of the first thrust bearing assembly and Figs. 3b and 3c are sectional views of individual bearing pads 30 in the directions of the arrows B-B and C-C respectively. The bearing assembly comprises eight thrust pads 30, supported by a housing 31 and retained therein by pins 32; the pins prevent the pads from being displaced relative to the housing but do not support them. The curvature of the pad 30 has been exaggerated in Fig. 3b for the sake of clarity (that is, the radius of curvature of the pad is shown reduced) but in practice the radius is so large that the

angle between the engaging surfaces at the line of contact is less than one degree of arc and typically about 0.25 degrees.

The second illustrated embodiment of a journal bearing assembly is shown in transverse sectional view in Fig. 4a and in a sectional view in a plane parallel to the axis of the shaft, in the direction of the arrows A-A, in Fig. 4b. As illustrated in Fig. 4a, the outer surface of each bearing pad 40 is of slightly smaller diameter (of the order of 0.1 per cent less) than the inner surface of the housing 41. In an axial direction, the inner surface of the housing is rectilinear and the outer surface of the pad 40 is very slightly convex, such that the surfaces diverge by an angle of about 0.1 degree of arc in that direction. These differences of curvature are exaggerated in the drawings in the interests of visual clarity.

Finally, the second illustrated form of thrust bearing is shown in Fig. 5a in transverse sectional view and in Figs. 5b and 5c as sectional views in the directions of the arrows A-A and B-B respectively. In the circumferential direction, the difference of curvature between the curved outer surface of the bearing 50 and the flat surface

of the housing 51 which it engages (which difference is exaggerated in Fig. 5b) is such as to give a contact angle of about one degree between the surfaces in that direction. In the radial direction, 5 the contact angle (exaggerated in Fig. 5c) is about 0.1 degree of arc.

As will be understood, the bearing assembly according to the present invention, in particular in its illustrated preferred forms, represents 10 a significant improvement over prior available bearing assemblies such as those discussed above. The susceptibility to instability in operation may be reduced to the point where it becomes negligible as a result of the oil squeeze effect 15 attributable to the interengagement of closely similar bearing pad and housing surfaces.

CLAIMS

1. A bearing assembly for supporting a rotatable shaft, which assembly comprises a plurality of bearing pads supported by a surrounding housing, the mutually engaging surfaces of each bearing pad and the housing being two surfaces of closely similar shape, which surfaces diverge in a first direction generally circumferential to the shaft and are each either rectilinear or only very slightly curved in a second direction generally at right angles to the first direction, the differences between the surfaces in said respective directions being such that the contact angle between the surfaces is less than three degrees of arc in said first direction and less than one degree of arc in said second direction.

2. A bearing assembly as claimed in Claim 1, wherein said contact angle is less than one degree of arc in said circumferential direction and less than 0.1 degree in said second direction.

3. A bearing assembly as claimed in either of the preceding claims, wherein the ratio of the contact angle in said first direction to that in said second direction is at least 5:1.

4. A bearing assembly as claimed in Claim 3, wherein said ratio is at least 10:1.

5. A bearing assembly as claimed in any of the preceding claims, wherein said two mutually
5 engaging surfaces are both rectilinear in said second direction.

6. A bearing assembly as claimed in Claim 5, wherein the difference in the radii of curvature of said surfaces in said first direction is less
10 than one per cent.

7. A bearing assembly as claimed in Claim 6, wherein said difference is less than 0.1 per cent.

8. A bearing assembly as claimed in any of
15 the preceding claims, wherein said bearing pads are held in position within the housing by locating pins.

9. A bearing pad assembly, substantially as hereinbefore described with reference to, and
20 as illustrated in, Figs. 2a and 2b or Figs. 3a, 3b and 3c of the accompanying drawings.

10. A bearing pad assembly substantially as hereinbefore described with reference to, and as illustrated in, Figs. 4a and 4b or Figs. 5b
25 and 5c of the accompanying drawings.



Application No: GB 9500406.5
Claims searched: 1-10

Examiner: Hal Young
Date of search: 4 April 1995

**Patents Act 1977
Search Report under Section 17**

Databases searched:

UK Patent Office collections, including GB, EP, WO & US patent specifications, in:
UK Cl (Ed.N): F2A
Int Cl (Ed.6): F16C (17/00, 03, 06 ; 32/06)
Other:

Documents considered to be relevant:

Category	Identity of document and relevant passage	Relevant to claims
X,P	GB2268549A (CHESTER) See figs 2a,3,7b and lines 5 of page 4 to line 14 of page 6.	1,2,8
A	EP0083987A2 (WAUKESHA)	
X	US4815865 (BRAUNSCHWEIGER) See figs 1,2,4.	1,5,8
X	US4636095 (GLYCO) See fig 1.	1,8

X	Document indicating lack of novelty or inventive step	A	Document indicating technological background and/or state of the art.
Y	Document indicating lack of inventive step if combined with one or more other documents of same category.	P	Document published on or after the declared priority date but before the filing date of this invention.
&	Member of the same patent family	E	Patent document published on or after, but with priority date earlier than, the filing date of this application.