



Europäisches Patentamt
European Patent Office
Office européen des brevets



(11) **EP 1 214 028 B1**

(12) **EUROPEAN PATENT SPECIFICATION**

(45) Date of publication and mention
of the grant of the patent:

21.07.2004 Bulletin 2004/30

(21) Application number: **00956145.7**

(22) Date of filing: **01.09.2000**

(51) Int Cl.7: **A61F 5/44**

(86) International application number:
PCT/DK2000/000478

(87) International publication number:
WO 2001/021115 (29.03.2001 Gazette 2001/13)

(54) **A COLLECTING BAG HAVING AN ACCOMMODATING MEANS FOR A CLOSURE DEVICE**

SAMMELBEUTEL MIT EINER EINRICHTUNG ZUM UNTERBRINGEN EINER
SCHLIESSVORRICHTUNG

POCHE DE RECUEIL MUNIE D'UN MOYEN DE LOGEMENT POUR DISPOSITIF DE FERMETURE

(84) Designated Contracting States:
**AT BE CH CY DE DK ES FI FR GB GR IE IT LI LU
MC NL PT SE**
Designated Extension States:
AL LT LV MK RO SI

(30) Priority: **17.09.1999 DK 991319**

(43) Date of publication of application:
19.06.2002 Bulletin 2002/25

(73) Proprietor: **COLOPLAST A/S**
3050 Humlebaek (DK)

(72) Inventors:
• **CIOK, Danuta**
DK-2990 Niva (DK)
• **VON BÜLOW, Martin**
DK-3000 Helsingør (DK)

(74) Representative: **Carlsson, Eva**
Internationalt Patent-Bureau,
23 Hoje Taastrup Boulevard
2630 Taastrup (DK)

(56) References cited:
EP-A- 0 185 809 **US-A- 3 650 272**
US-A- 3 865 165 **US-A- 4 306 029**
US-A- 4 449 971

EP 1 214 028 B1

Note: Within nine months from the publication of the mention of the grant of the European patent, any person may give notice to the European Patent Office of opposition to the European patent granted. Notice of opposition shall be filed in a written reasoned statement. It shall not be deemed to have been filed until the opposition fee has been paid. (Art. 99(1) European Patent Convention).

Description

[0001] The present invention relates to a collecting bag for human body wastes comprising a bag member formed by two film blanks with joined edges defining the outer contours of the bag member, an inlet opening provided in one of said film blanks, connecting elements surrounding said inlet opening for connection of the bag to a body orifice, a discharge portion at a distance from the inlet opening comprising a discharge opening, a closure device at the discharge portion for bringing the bag from a discharge position, in which the bag is open, to a position of use, in which the bag is closed, and accommodating means for accommodating said closure device in the position of use of the bag.

[0002] In such collecting bags the discharge portion is normally temporarily attached to the bag member in the position of use of the bag in order to attain a compact appearance in this position and to prevent the discharge portion and the closure device from dangling which might be uncomfortable to the user. In bags having an elongated, substantially flat discharge portion, this portion is folded or rolled up in the direction of the bag member, partly in order to close the bag and partly to attain said compact appearance and the attachment to the bag member.

[0003] WO96/19164 discloses a collecting bag of this kind in which the discharge portion is rolled up on a clip fastened to one of the film blanks.

[0004] GB patent applications Nos. 2 268 065 and 2 000 683 disclose collecting bags, in which strips of the interlocking-elements type, such as Velcro, are placed on each of the film blanks of the discharge portion and which after rolling or folding the discharge portion tightly are brought into contact with each other.

[0005] In EP patent application No. 13 109 the folded discharge portion is tucked into a gap provided between a strip fixed to one wall of the bag and the wall itself.

[0006] In all of the above documents it is a prerequisite that the discharge portion is substantially flat. In collecting bags having a closure device of some extent, eg. a valve or a clamp, these solutions may not be applied.

[0007] US patent No. 2,520,831 discloses a collecting bag in which the folded discharge portion, which is closed by means of a clamp, is accommodated in a pouch provided at the proximal end of the discharge portion in the position of use of the bag, in which the pouch is closed by means of a zipper-like slide fastener. Due to the structure of the elements of the closure device, opening and closing of the bag require some dexterity, eg. the discharge portion has to be held manually within the pouch when activating the slide fastener and has to be withdrawn from the pouch in order to empty the bag. In addition, the use of a slide fastener renders the manufacture of the collecting bag expensive and cumbersome.

[0008] US patent No. 4,519,797 discloses a cover for an ostomy pouch having a drain fitting at the bottom of

the pouch. The cover has an opening allowing the pouch to be mounted in the usual manner on the plate worn by the patient. The cover has an integral pocket which receives the drain fitting to prevent irritation to the sensitive portions of the anatomy.

[0009] This solution, however, while preventing the drain fitting from directly contacting sensitive portions of the anatomy, contributes to the bulkiness of the pouch, thereby compromising the demand for discretion.

[0010] US patent No. 4,449,971 discloses a collecting bag of the initially stated kind, in which the accommodating means in the form of a pocket having an entrance slit is formed on an extension of the bag member. Similar arrangements are shown in e.g. US patents Nos 3,865,165 and 4,306,029.

[0011] The object of the present invention is to improve a collecting bag of the kind mentioned in the introduction with respect to ease of operation and manufacturing conditions and which furthermore may be used regardless of the type of closure device, at the same time improving both the comfort and the discretion.

[0012] For achieving this, a collecting bag according to the invention is characterized in that said accommodating means has a basis portion in which said film blanks are undetachably connected to each other, and that the periphery of the basis portion is situated at a distance from the joined edges of the bag member and the discharge portion.

[0013] By the provision of an accommodating means in the form of an open receptacle having a basis portion, it is very simple to place the closure device in the accommodating means. The position of the basis portion entails that the outer contours of the bag member are not affected by the accommodating means, and at the same time, a free passage is provided from the bag member to the discharge portion. The undetachable connection between the film blanks makes it possible to lodge the closure device in its entirety in the accommodating means so that it does not protrude outside the arched planes formed by the film blanks when the bag is expanded by the contents. Furthermore, the accommodating means may be formed in an easy and inexpensive manner thus reducing the manufacturing and material costs.

[0014] In the following the invention will be described in further detail with reference to the schematic drawings, in which the bag is shown in the shape it will assume when at least partly filled and

50 Fig. 1 shows a side view of a collecting bag according to the invention in a discharge position;
 Fig. 2 shows a plan view of the collecting bag shown in Fig. 1;
 Fig. 3 shows a plan view of the collecting bag in a position of use;
 55 Fig. 4 shows a cross-sectional view of the collecting bag along the line IV-IV in Fig. 3;
 Fig. 5 shows a side view of the collecting bag in the

position shown in Fig. 3; and
Fig. 6 shows a longitudinal section of the collecting bag along the line VI-VI in Fig. 3.

[0015] The collecting bag shown in the drawings comprises a bag member 1 formed by two film blanks 2,3 which are joined along their edges by means of a seam 4 made by welding or in any other convenient manner and defining the outer contours of the bag member. The film blanks may be made from any suitable flexible plastic sheet or foil material.

[0016] In the film blank 3 which in use is intended to face the user and thus forms the back wall of the bag, an inlet opening, not shown, is provided which in a manner known *per se* is surrounded by connecting elements 5 for connection of the bag to a body orifice in the form of a so-called stoma in the user's abdominal wall.

[0017] At a distance from the inlet opening and the connecting elements 5, the bag is designed with a discharge portion 6 having a discharge opening, not shown in detail, through which the bag may be emptied of its contents.

[0018] In order to bring the bag from the open or discharge position shown in Figs. 1 and 2 to a position of use, in which the bag is closed, the collecting bag comprises a closure device 7 which in the embodiment shown is designed as a valve but which as well be designed in any other way.

[0019] An accommodating means 8 for accommodating the closure device 7 in the position of use of the collecting bag is designed in the bag member 1. The accommodating means comprises an open receptacle with a basis portion 9 surrounded by portions 2a of the front film blank 2. In the basis portion 9 the two film blanks 2,3 are, as most clearly seen in Figs. 4 and 6, connected to each other in an undetachable manner, eg. by means of a welded or heat-sealed joint extending along the periphery 9a of the basis portion 9 or by gluing the film blanks together in this area. As seen in Figs. 3 to 6 the closure device 7 is accommodated in the accommodating means 8 in its entirety and does not protrude outside the outer contours of the bag in the plane of the bag, neither does it protrude outside the arched plane defined by the remaining portions 2b of the front film blank. Thus, a very compact appearance of the bag is obtained in the position of use.

[0020] It is of course conceivable, although not preferred, to place the closure device in the corresponding receptacle formed at the back of the bag member.

[0021] In order to improve the securing of the closure device 7 in the open receptacle formed by the basis portion 9 and the portions 2a of front film blank 2 surrounding the basis portion 9, the accommodating means may further comprise a retaining means, which in the embodiment shown is provided in the shape of a strip 10 which in one end is undetachably connected to the bag member and in the other end has an engagement section for releasable engagement with a corresponding section on

the bag member. The engagement sections may comprise interlocking elements, eg. of the Velcro type. The strip 10 may also be undetachably secured in a middle section and have foldable ends with corresponding engagement sections, said foldable ends having lengths enabling them to reach around the closure device 7 for engagement or it may be provided separately and comprise an engagement section in each end.

[0022] Other types of retaining means may be conceivable, eg. it is possible to provide the closure device itself with an engagement section for releasable engagement with a corresponding section in the basis portion.

[0023] The periphery 9a of the basis portion 9 is situated at a distance from the joined edges of the bag member, ie. the seam 4, and the discharge portion 6 in order to permit the contents of the bag to flow out of the discharge portion 6 and the discharge opening during emptying of the bag. It is of course possible to place the accommodating means in the vicinity of one of the edges as long as there is still a free passage between the bag member and the discharge portion.

[0024] The basis portion 9 of the accommodating means has cross-sectional dimensions corresponding to the dimensions of the closure device 7. By this design, a safe retention of the closure device in the accommodating means 8 is obtained and at the same time the volume available for body wastes in the remaining part of the bag is reduced as little as possible.

[0025] The invention should not be regarded as being limited to the embodiment described in the above but various modifications may be carried out without departing from the scope of the following claims.

[0026] For example, although the invention has been described only with reference to one kind of closure device, viz. a valve, it is of course possible to apply it to other forms of closure devices comprising eg. clamps or adhesive connections.

Claims

1. A collecting bag for human body wastes comprising:

a bag member (1) formed by two film blanks (2,3) with joined edges defining the outer contours of the bag member,

an inlet opening provided in one of said film blanks (3),

connecting elements (5) surrounding said inlet opening for connection of the bag to a body orifice,

a discharge portion (6) at a distance from the inlet opening comprising a discharge opening, a closure device (7) at the discharge portion (6) for bringing the bag from a discharge position, in which the bag is open, to a position of use,

in which the bag is closed, and accommodating means (8) for accommodating said closure device (7) in the position of use of the bag, comprising at least one open receptacle formed in said bag member (1) within said outer contours **characterized in that** said accommodating means (8), has a basis portion (9) in which said film blanks (2,3) are undetachably connected to each other, and that the periphery (9a) of the basis portion (9) is situated at a distance from the joined edges (4) of the bag member (1) and the discharge portion (6).

2. A collecting bag according to claim 1, **characterized in that** said film blanks (2,3) are connected to each other by means of a heat-sealed joint extending along the periphery (9a) of the basis portion (9).
3. A collecting bag according to claim 1, **characterized in that** said film blanks (2,3) are connected to each other by gluing.
4. A collecting bag according to any of claims 1 to 3, **characterized in that** said accommodating means (8) comprises a retaining means (10) for holding the closure means (7) in said open receptacle in the position of use of the bag.
5. A collecting bag according to claim 4, **characterized in that** said retaining means comprises a strip (10) having at least one engagement section for releasable engagement with a corresponding section or corresponding sections on said bag member (1) or on the opposite end of said retaining means.
6. A collecting bag according to any claims 1 to 5, **characterized in that** said basis portion (9) has cross-sectional dimensions corresponding to the dimensions of the closure device (7).

Revendications

1. Poche de recueil pour déjections corporelles humaines, comprenant :
 - un pochon (1) constitué de deux pans (2, 3) en film à bords solidarisés, définissant le profil extérieur dudit pochon,
 - un orifice d'admission ménagé dans l'un (3) desdits pans en film,
 - des éléments de liaison (5) entourant ledit orifice d'admission, en vue d'une liaison de la poche avec un orifice corporel,
 - une zone de décharge (6), située à distance de l'orifice d'admission et munie d'un orifice de décharge,

un dispositif de fermeture (7) situé dans la zone de décharge (6) pour amener la poche d'une position de décharge, dans laquelle ladite poche est ouverte, à une position d'utilisation dans laquelle ladite poche est fermée, et un moyen de logement (8) pour loger ledit dispositif de fermeture (7) dans la position d'utilisation de la poche, comprenant au moins un réceptacle ouvert ménagé dans ledit pochon (1), dans les limites dudit profil extérieur, **caractérisée par le fait que** ledit moyen de logement (8) possède une région de base (9) dans laquelle lesdits pans (2, 3) en film sont reliés l'un à l'autre de manière indissociable ; et **par le fait que** la périphérie (9a) de ladite région de base (9) se situe à distance des bords solidarisés (4) dudit pochon (1) et de la zone de décharge (6).

2. Poche de recueil selon la revendication 1, **caractérisée par le fait que** lesdits pans (2, 3) en film sont reliés l'un à l'autre au moyen d'un joint thermoscellé s'étendant le long de la périphérie (9a) de la zone de base (9).
3. Poche de recueil selon la revendication 1, **caractérisée par le fait que** lesdits pans (2, 3) en film sont reliés l'un à l'autre par collage.
4. Poche de recueil selon l'une quelconque des revendications 1 à 3, **caractérisée par le fait que** ledit moyen de logement (8) comprend un moyen de retenue (10) pour retenir le moyen de fermeture (7) dans ledit réceptacle ouvert, dans la position d'utilisation de ladite poche.
5. Poche de recueil selon la revendication 4, **caractérisée par le fait que** ledit moyen de retenue comprend un ruban (10) muni d'au moins une zone de coopération pour établir une venue en prise libérable avec une zone correspondante ou des zones correspondantes, sur ledit pochon (1), ou sur l'extrémité opposée dudit moyen de retenue.

6. Poche de recueil selon l'une quelconque des revendications 1 à 5, **caractérisée par le fait que** ladite région de base (9) présente des cotes de section transversale correspondant aux cotes du dispositif de fermeture (7).

Patentansprüche

1. Sammelbeutel für menschliche Ausscheidungen, umfassend:
 - ein durch zwei Folienzuschnitte (2, 3) gebildetes Beutelement (1) mit verbundenen Rän-

dern, die die äußeren Umrisse des Beutelements definieren,
 eine in einem der Filmzuschnitte (3) vorgesehene Einlassöffnung, Verbindungselemente (5), die die Einlassöffnung für eine Verbindung mit einer Körperöffnung umgeben,
 einen Austragabschnitt (6), der eine Austragöffnung umfasst, in einem Abstand von der Einlassöffnung,
 eine Verschlussvorrichtung (7) an dem Austragabschnitt (6), um den Beutel von einer Austragstellung, in der der Beutel offen ist, in eine Gebrauchsstellung, in der der Beutel geschlossen ist, zu bringen, und
 ein Unterbringungsmittel (8), um die Verschlussvorrichtung (7) in der Gebrauchsstellung des Beutels unterzubringen, das zumindest eine offene Aufnahme umfasst, die in dem Beutelement (1) innerhalb seiner äußeren Umrisse ausgebildet ist,

5

10

15

20

dadurch gekennzeichnet, dass

das Unterbringungsmittel (8) einen Basisabschnitt (9) aufweist, in welchem die Folienzuschnitte (2, 3) nicht trennbar miteinander verbunden sind,
 und dass der Umfang (9a) des Basisabschnitts (9) in einem Abstand von den verbundenen Rändern (4) des Beutelements (1) und dem Austragabschnitt (6) angeordnet ist.

25

30

2. Sammelbeutel nach Anspruch 1,
dadurch gekennzeichnet, dass
 die Folienzuschnitte (2, 3) mittels einer heiß geklebten Naht, die sich entlang des Umfangs (9a) des Basisabschnitts (9) erstreckt, miteinander verbunden sind.
3. Sammelbeutel nach Anspruch 1,
dadurch gekennzeichnet, dass
 die Folienzuschnitte (2, 3) mittels Kleben miteinander verbunden sind.
4. Sammelbeutel nach einem der Ansprüche 1 bis 3,
dadurch gekennzeichnet, dass
 das Unterbringungsmittel (8) ein Haltemittel (10) umfasst, um das Verschlussmittel (7) in der offenen Aufnahme in der Gebrauchsstellung des Beutels zu halten.
5. Sammelbeutel nach Anspruch 4,
dadurch gekennzeichnet, dass
 das Haltemittel eine Streifen (10) umfasst, der zumindest einen Eingriffabschnitt für einen lösbaren Eingriff mit einem entsprechenden Abschnitt oder entsprechenden Abschnitten an dem Beutelement (1) oder an dem gegenüber liegenden Ende des Haltemittels aufweist.

35

40

45

50

55

60

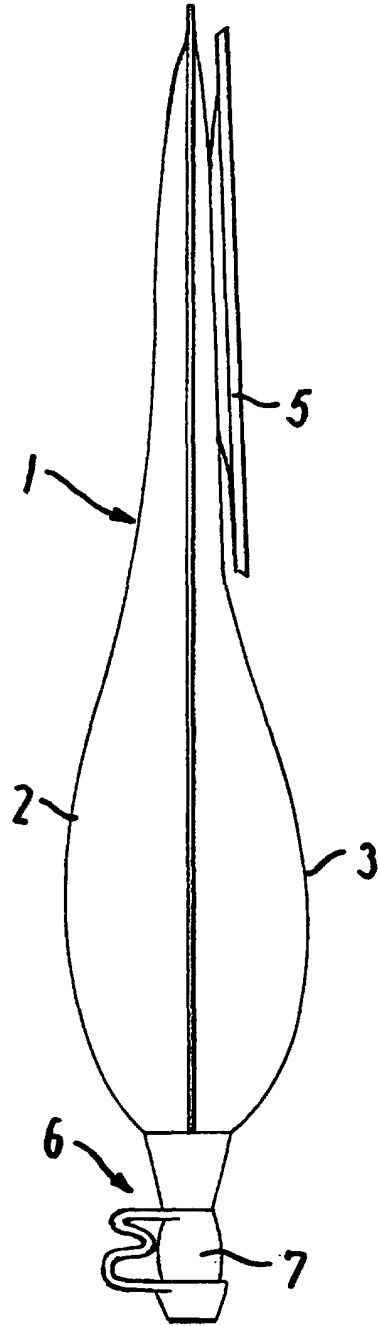

FIG.1

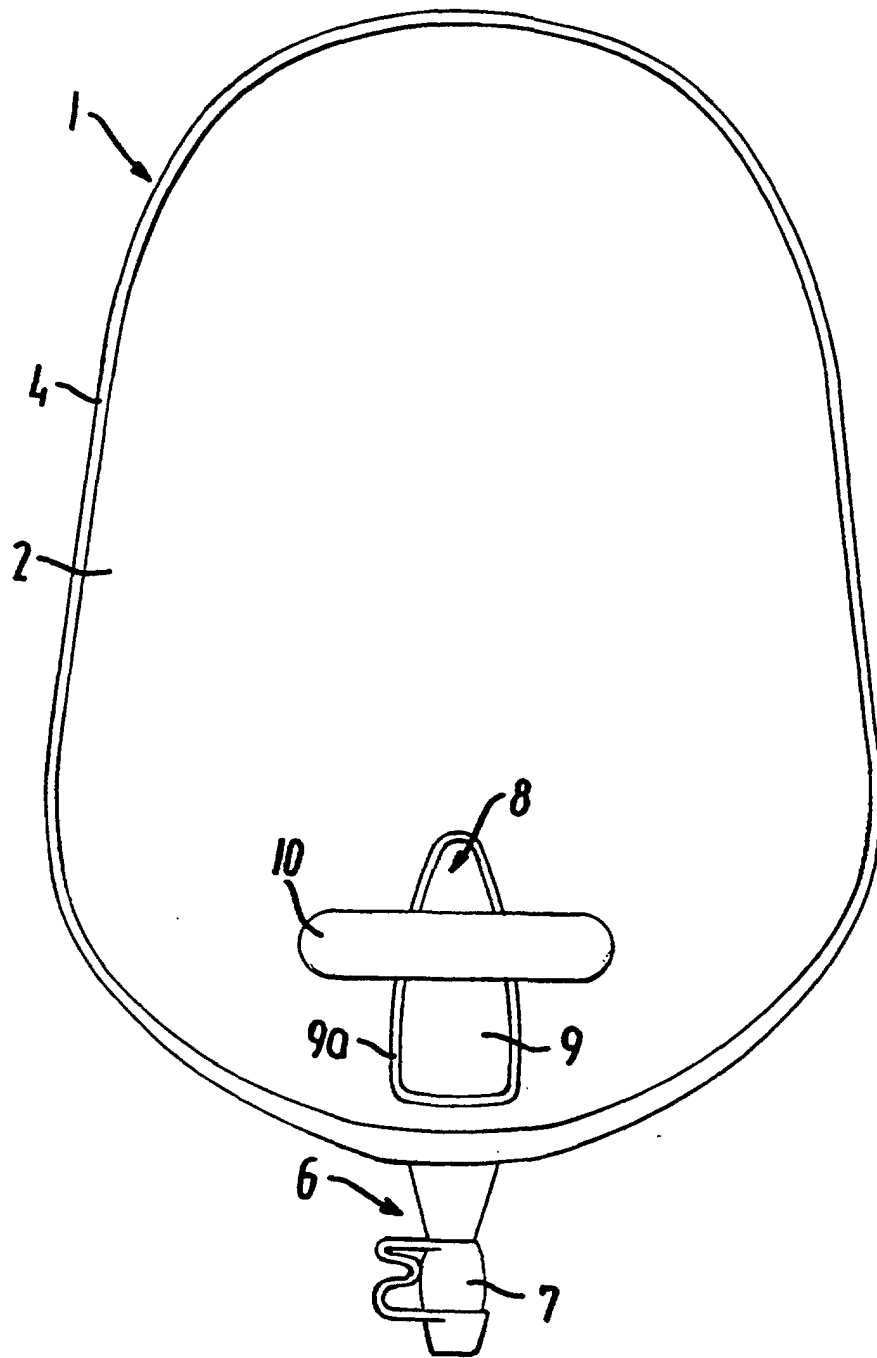
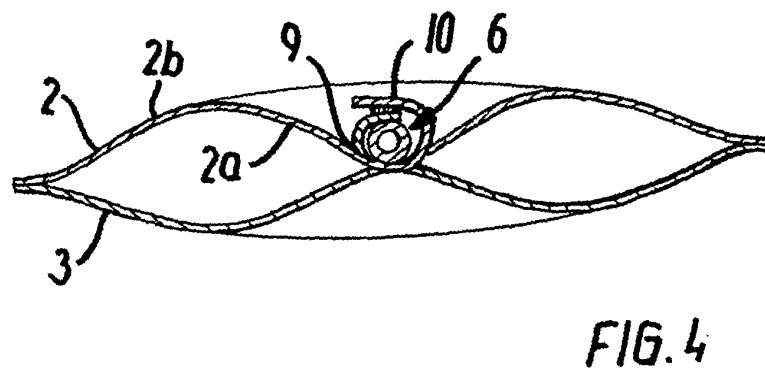
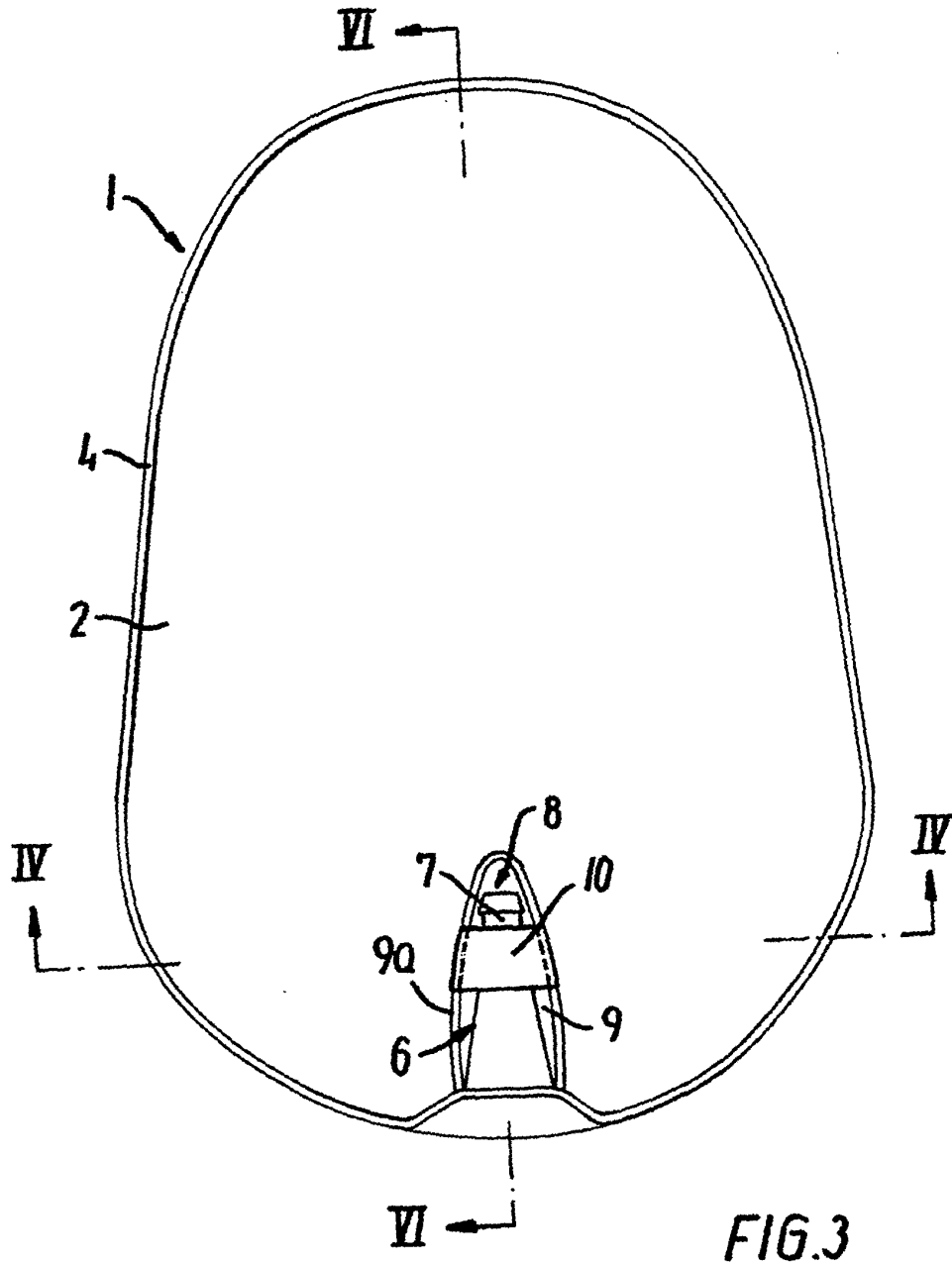

FIG.2



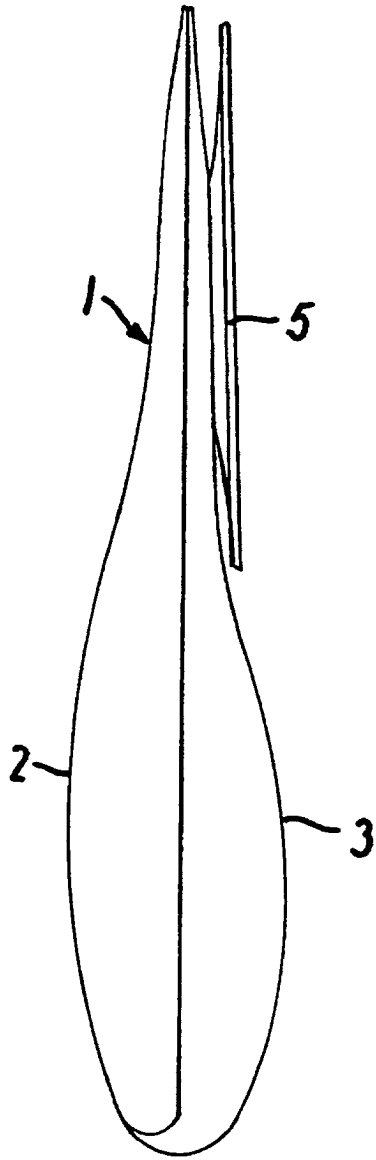

FIG. 5

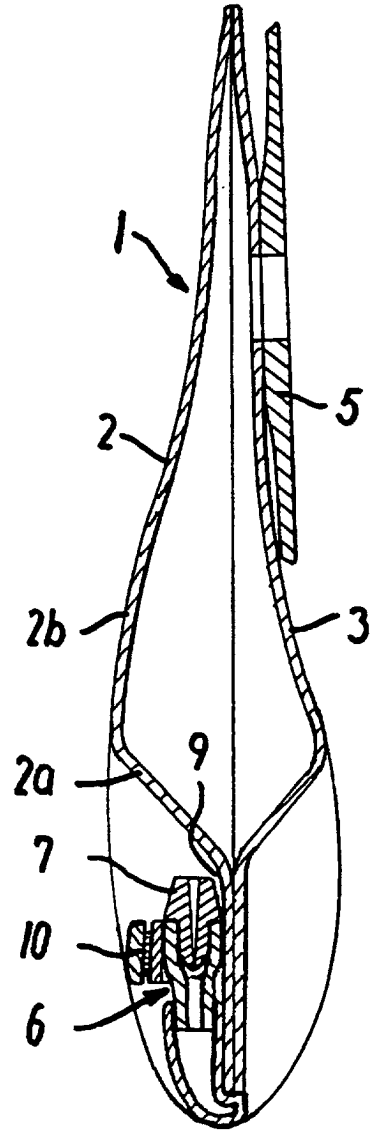

FIG. 6