



INTERNATIONAL APPLICATION PUBLISHED UNDER THE PATENT COOPERATION TREATY (PCT)

(51) International Patent Classification⁴ : B43K 5/00	A1	(11) International Publication Number: WO 87/ 01337 (43) International Publication Date: 12 March 1987 (12.03.87)
<p>(21) International Application Number: PCT/US86/01411</p> <p>(22) International Filing Date: 3 July 1986 (03.07.86)</p> <p>(31) Priority Application Number: 770,215</p> <p>(32) Priority Date: 28 August 1985 (28.08.85)</p> <p>(33) Priority Country: US</p> <p>(71) Applicant: COOPERVISION, INC. [US/US]; 3145 Porter Drive, Palo Alto, CA 94304 (US).</p> <p>(72) Inventor: BEUCHAT, Charles, E. ; 6 Westport, Irvine, CA 90720 (US).</p> <p>(74) Agents: BOLAND, Thomas, R. et al.; Vorys, Sater, Seymour and Pease, 1828 L Street, N.W., Suite 1111, Washington, DC 20036-5104 (US).</p>		<p>(81) Designated States: AT (European patent), AU, BE (European patent), BR, CH (European patent), DE (European patent), DK, FI, FR (European patent), GB (European patent), IT (European patent), JP, KR, LU (European patent), NL (European patent), NO, SE (European patent).</p> <p>Published <i>With international search report.</i></p>

(54) Title: PIGMENT DISPENSER AND RESERVOIR FOR A PIGMENTATION SYSTEM**(57) Abstract**

A device for controlling the dispensing of pigments suspended in solution for reciprocating needles that penetrate the skin. For use in an apparatus of the type which included a tip assembly (12), including a needle (13) secured to a reciprocating head (14) driven by a motor (18), an adapter member (30) is disclosed having a generally axially aligned chamber (32), a portion (33) of which is manually secured to the tip assembly (12). The adapter member (30) also defines an inclined chamber (36) for receiving a pigment containing reservoir member (40) with a transfer tube (47). A weighted wire (60) has a portion (61) located within the transfer tube (47). The wire (60) includes a second portion (63) which resides within the reservoir member (40) so that when the reservoir member (40) with its pigment solution and wire (60) is inserted into the adapter member (30), reciprocation of the tip assembly (12) causes the wire (60) to agitate the pigment suspension while controlling flow of the pigment-containing solution to the lower portion (34) of the axially aligned chamber (32) in the adapter member (30), and hence to the needle (13).

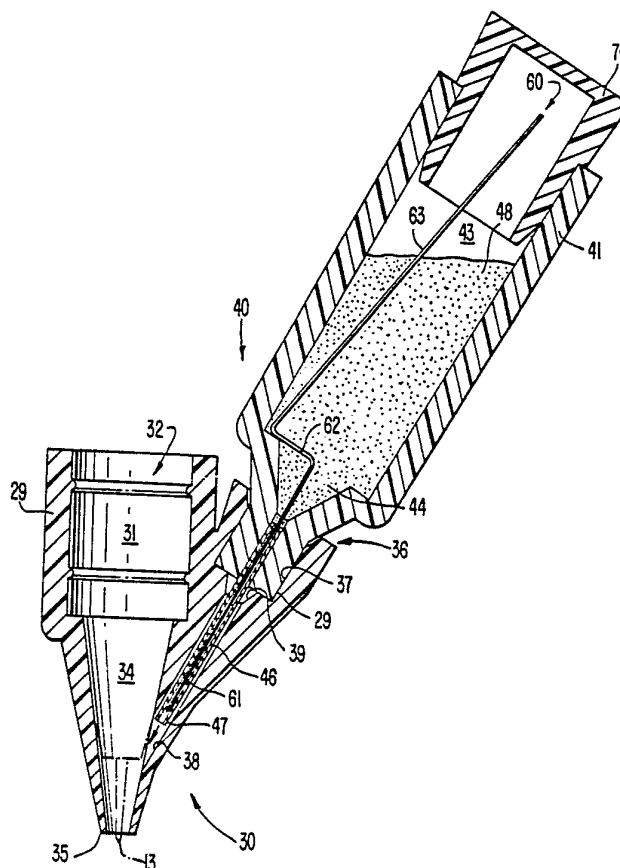

FOR THE PURPOSES OF INFORMATION ONLY

Codes used to identify States party to the PCT on the front pages of pamphlets publishing international applications under the PCT.

AT	Austria	GA	Gabon	MR	Mauritania
AU	Australia	GB	United Kingdom	MW	Malawi
BB	Barbados	HU	Hungary	NL	Netherlands
BE	Belgium	IT	Italy	NO	Norway
BG	Bulgaria	JP	Japan	RO	Romania
BR	Brazil	KP	Democratic People's Republic of Korea	SD	Sudan
CF	Central African Republic	KR	Republic of Korea	SE	Sweden
CG	Congo	LI	Liechtenstein	SN	Senegal
CH	Switzerland	LK	Sri Lanka	SU	Soviet Union
CM	Cameroon	LU	Luxembourg	TD	Chad
DE	Germany, Federal Republic of	MC	Monaco	TG	Togo
DK	Denmark	MG	Madagascar	US	United States of America
FI	Finland	ML	Mali		
FR	France				

- 1 -

PIGMENT DISPENSER AND RESERVOIR FOR A PIGMENTATION SYSTEMBACKGROUND OF THE INVENTION

This invention relates to an automatic pigment dispenser for controlling the dispensing of pigment suspended in solution to the reciprocating needles that penetrate the skin, particularly adapted for a device used for implanting a pigment in the skin. More particularly, this invention relates to a reservoir for dispensing pigment through a transfer tube containing a vibrating wire to prevent clogging of the transfer tube. Still more particularly, this invention relates to a disposable adapter for attachment to a head of a pigment-implanting unit, wherein the adapter houses the pigment reservoir and transfer tube in an angled relationship with the axis of the reciprocating needle to control the dispensing of pigment to the needle.

A method and apparatus are known for applying sterile pigment in the superficial dermis along the edge of the eye lid and the lash line. Such a procedure has, among other advantages, reduced the potential for an allergic reaction to the application of cosmetics to the area of the eye, assisted the handicapped in applying cosmetics, and reduced irritation and infection which might develop from eye makeup flaking into the eye of contact lens wearers.

Such a method and apparatus for applying pigment in the area of the eye is described in United States Patent No. 4,508,106 to Giora G. Angres. There, a method is described for applying a cosmetic liner to the edge of an eye lid using the steps of anesthetizing the portion of the eye lid in the area adjacent the lid, stabilizing the portion of the eye lid to which the permanent liner is to be applied, and penetrating the skin to a predetermined depth in the dermis with a pigment suspension along the line defining the intended location of the eye liner and

- 2 -

into the deep layers of the skin and/or lid margins and
lash line. An apparatus is also described for penetrating
the skin with a pigment suspension having a reciprocating
needle structure in combination with an enveloping cone
5 structure which protects the needles, insures proper
penetration, and stores the pigment suspension.

Such an apparatus of the type described is
available which includes one of a plurality of needles
which project from the end of a needle mount member to
10 extend slightly beyond an opening at the end of a hollow
cone element connected to the head of the instrument. The
end of the cone is dipped in an aqueous pigment suspension
to permit the solution to enter the hollow portion of the
cone where the suspension is retained by capillary action.
15 The needle or needles are also immersed in the aqueous
suspension which is retained in the space between the
needles by capillary action. After dipping the cone in
the aqueous pigment suspension, the needles are
reciprocally driven with a short stroke to penetrate the
20 skin to a predetermined limited depth to apply the pigment
thereto.

Such a procedure for retaining the pigment for
application to the needle is cumbersome and requires the
operator to remove the excess pigment before starting an
25 implantation procedure. When the excess is wiped away
from the needles, at least some of the excess pigment
accumulated within the cone is also wiped away by
capillary action and thus lost, requiring repetitive
immersion during the procedure to replenish the pigment
30 supply. This technique thus also risks dulling the
needles. In addition, the procedure is somewhat untidy
and time consuming.

Accordingly, it is an overall object of this
invention to provide for the controlled application of a
35 pigment suspension directly to the reciprocating needles
in such an apparatus.

- 3 -

An automatic pigment dispensing feature is provided on an available micropigmentation system which includes a cavity surrounding the reciprocating needle. The cavity is filled with pigment. However, such a solution has not been entirely satisfactory because of difficulties encountered in supplying a controlled amount of pigment to the reciprocating needle assembly. In effect, that solution results in providing the pigment suspension at one time rather than controlling the dispensing of the pigment suspension to the reciprocating needle assembly during the application procedure. Moreover, the storing of the relatively viscous pigment suspended in an aqueous medium is difficult in that structure because of its tendency to clog, and because of that tendency of the pigment to settle from its suspension.

Accordingly, it is a continuing problem in the art to provide a method and apparatus for controlling the dispensing of a pigment suspension to the reciprocating needles that penetrate the skin in the procedure of the type described.

It is an additional object of this invention to provide a reservoir for containing and dispensing pigment to a reciprocating needle in such a procedure wherein the reservoir includes a simple and effective means for preventing clogging of the transfer tube while continually agitating the relatively viscous pigment solution during an implantation procedure.

It is still an additional object of this invention to provide such a method and apparatus which are readily adaptable to converting an existing apparatus and instrument in the field.

It is another object of this invention to provide a reservoir for use in such controlled dispensing wherein the reservoir contains sufficient pigment to

- 4 -

perform the entire procedure without requiring the operator to stop and refill the reservoir with additional aqueous pigment.

5 These and other objects of the invention will become apparent from the detailed description of the invention which follows.

SUMMARY OF THE INVENTION

10 Directed to achieving the foregoing objects and overcoming the problems with the prior art apparatus for applying a pigment solution to the skin, the apparatus according to the invention comprises an adapter member which is readily fitted to the head of an available device of the type which includes a disposable tip assembly used to place the pigment into the dermis. Such a device 15 includes a tip assembly, a reciprocating head, a hand held drive unit, a motor, and an extensible cord secured to a console for controlling the reciprocation of the tip assembly. The adapter member thus comprises a first chamber which, when the adapter member is connected to the 20 head of such unit, is generally axially aligned with the axis of the tip assembly and fits thereon so that the tip of the needle or needles used in the procedure extends below the lowermost surface of the axially aligned first chamber a predetermined distance, such as 1/16 of an inch, 25 to control penetration of the needles into the dermis. Preferably, the axially aligned first chamber has two portions, the upper portion being generally circular in cross section to be comfortably slip fitted onto the lower portion of the head of the unit, and the lower portion 30 being generally conically shaped for receiving metered pigment from the transfer tube of the reservoir.

The body of the adapter member also includes an inclined chamber for receiving a pigment reservoir therein at an angle to the axis of reciprocation of the needle. 35 The reservoir comprises a pigment-receiving outer chamber

- 5 -

for receiving pigment therein and a cap, thus terminating at its lower portion in a conical transfer section leading to a transfer tube having a predetermined diameter. A wire is manually fixed in the transfer tube so that operation of the unit causes a slight reciprocation of the wire thus agitating the aqueous pigment solution in the pigment-receiving chamber in the reservoir. The diameter of the transfer tube is selected to permit, in cooperation with the diameter of the wire therein, a sufficient clearance between the wire and the inside diameter of the transfer tube to permit metered dispensing of the aqueous pigment solution as a function of its viscosity through capillary action. Preferably, the pigment reservoir assembly is press fitted into the obliquely inclined chamber in the adapter member so that the transfer tube extends significantly toward the intersection of the lower conical portion of the adapter member.

A method of using such a device with a pigmentation unit is also described which comprises the steps of providing a reservoir adapter member which is structurally adapted to be press fitted to the head of the unit, securing the reservoir adapter member to the unit, providing a separate pigment reservoir having a pigment chamber and a transfer tube in communication therewith, inserting a wire having a predetermined shape into the pigment reservoir so that a portion of the wire extends within the transfer tube, inserting an aqueous pigment solution into the pigment reservoir, closing the reservoir with a cap to secure the pigment solution therein, inserting the reservoir with its pigment solution into the obliquely inclined chamber of the reservoir adapter secured to the head of the unit, and performing the pigmentation procedure on a patient.

BRIEF DESCRIPTION OF THE DRAWINGS

In the drawings:

- 6 -

Fig. 1 is a pictorial illustration of the components of a prior art apparatus for applying a pigment solution by a surgical procedure to the dermis of a patient;

5 Fig. 2 is a pictorial illustration, partially in phantom, showing the adapter member according to the invention secured to the head of the unit of Fig. 1 and having the pigment reservoir in place; and

10 Fig. 3 is a cross sectional view of the combination of the adapter and reservoir shown in Fig. 2 and further showing the wire extending into the transfer tube of the pigment reservoir.

DETAILED DESCRIPTION OF A PREFERRED EMBODIMENT

Fig. 1 shows a representative embodiment of a
15 prior art system for implanting pigment in the dermis of a patient according to procedures known to the prior art. The system is designated generally by the reference numeral 10. The system 10 includes a disposable tip assembly 12, used to place the pigment into the dermis by
20 reciprocating a needle or a plurality of needles 13 secured to a reciprocating head 14 which can be easily removed for cleaning. The adapter member and the controlled pigment dispenser according to the invention are attached to the reciprocating head 14, as will be
25 discussed in connection with Figs. 2 and 3. The reciprocating head 14 is attached to a hand-held drive unit 16 formed with a gripping shape to permit the operator, usually a physician, to practice the procedure. The shape of the drive unit is designed to insure maximum
30 manual control. The drive unit 16 is connected to a motor 18 electrically connected to an extensible flexible cord 20 with plug connectors 19 and 21 which plug the motor 18 to the face of a console unit 22. Reference may be made to the Angres patent, No. 4,508,106, which is
35 incorporated by reference, for a workable example of the

- 7 -

details of the components of the system 10 shown in Fig. 1 and a description of the prior art procedure. The console 22 includes the appropriate wiring and power connections, including a pulse rate display 24 for displaying the pulse rate of reciprocation of the tip assembly 12. A control member 26 sets the maximum pulse rate, by varying voltage, which is delivered to the handpiece, comprising the tip assembly 12, the reciprocating head 14, the drive unit 16, and the motor 18. Preferably, the console 22 is connected to a foot switch (not shown) which linearly controls the pulse rate of the handpiece tip.

In use, the handpiece assembly 10, but without the tip assembly 12, is connected to the front of the console 22. The disposable tip assembly 12 is removed from a sterile package and threaded tightly into the reciprocating head 14. A needle or plurality of needles 13 with a protective cover attached is pressed into the tip assembly 12 and the protective cover removed from the needle 13 so that the excursion rate of the needle can be observed for accuracy. Thereafter, the pigmentation procedure is performed whereupon the unit may be disassembled.

As shown in Figs. 2 and 3, the adapter member according to the invention is designated generally by the reference numeral 30. The adapter member 30 is sized and constructed to be slip-fitted to securely engage at its inside diameter the outer periphery of the downwardly-extending surface 31 of the disposable tip assembly 14. The adapter member 30 defines an axially oriented chamber designated generally by the reference numeral 32 positioned in a one-piece body 29 of the adapter member 30. When in place, the axis of the chamber 32 is axially aligned with the axis of reciprocation of the tip assembly 12 to which the needle 13 is secured and reciprocates with the tip assembly during the implant

- 8 -

procedure. Preferably, the body 33 of the adapter member 30 is made from a suitable plastic material, such as polypropylene, by a suitable process such as molding. The chamber 32 is defined by a first or upper portion 33 which is generally circular in cross section for mating with the corresponding downwardly extending surface of the tip assembly 12 in a snug, secure relationship. The chamber 32 further defines a lower or second portion 34 which is generally conically shaped for receiving therein the lower portion of the tip assembly 12 and the needle 13 extending from the lowermost end 35 thereof by a predetermined distance to limit the depth of penetration for introduction of the pigment into the dermis. The chamber 32 is thus structurally adapted to be retrofitted on units of the type shown in Fig. 1. Alternatively, the tip assembly 12 could also be molded to integrally form therein the member 30 with the feature described.

The body 29 of the adapter member 30 further defines an obliquely inclined chamber 36 having an outer chamber portion 37 communicates with an inner chamber portion 38 which terminates at its lower end in the wall of the chamber 34 of the axially aligned chamber 32. The outer chamber portion 37 is defined by a circular cross section and a predetermined length terminating gradually by a transition portion 38 with the lower chamber portion 38 which is generally tubular in shape.

A pigment reservoir 40, provided as a separate piece, includes a body 41 acting as a pigment reservoir with an outer chamber 43 defined by a circular cross section and a conically shaped inner chamber 44 terminating at its lower end in an opening 46 for receiving a transfer tube 47 in a press-fit relationship. Together, the chambers 43 and 44 and the transfer tube 47 define a reservoir for storing and containing a supply of aqueous pigment solution and metering the aqueous pigment

- 9 -

suspension, as will be further described, into the chambers 38 and 34 to wet the needle 13 to perform the pigmentation procedure.

In order to control the dispensing of the aqueous but viscous pigment suspension 48 from the reservoir 40 to the chamber 34 through the tube 47, a shaped, weighted wire 60, preferably made from stainless steel, is inserted so that a linear portion 61 is contained within the tube 47. A radially extending portion 62 terminates in an obliquely inclined portion 63 so that the wire 60 is preferably bent according to the contours shown in Fig. 3. With the pigment reservoir 40 inserted into the chamber 36 in the adapter member 30, reciprocation of the needle during the procedure causes the wire 60 to vibrate slightly thus preventing clogging of the aqueous pigment suspension in the transfer tube while continuously agitating the pigment suspension.

The diameter of the transfer tube 47 is determined so that the annular cross section defined by the inside diameter of the transfer tube 47 and the outside diameter of linear portion 61 of the wire 60 are sized relative to the viscosity of the aqueous pigment suspension to permit the pigment suspension to be metered through the transfer tube in the obliquely inclined chambers 38 at a controlled rate to wet the needle 13. By way of specific example, a wire 60 of .010" diameter in a tube 47 having a .023 I.D. has proven satisfactory for a conventional pigment solution. Thus, a controlled amount of pigment is provided to the reciprocating needle 13. The dimension of the chamber 34 is such to retain the pigment solution by a capillary action to wet the needle 13. By way of completeness of the disclosure, a preferable pigment comprises iron oxide suspended in isopropyl alcohol.

- 10 -

The device according to the invention eliminates the need for an operator to dip a needle or needles 13 into a bowl of pigment solution and then remove the excess before starting the operation, and also eliminates much of the excess pigment that accumulates inside the protective cone of the prior art when an operator tips the needles too far into the pigment.

A cap member 70 is provided to close the upper portion of the chamber containing the pigment solution.

In use, the adapter member 30 is removed from a sterile package and is slid over the tip assembly 12 so that the surface 31 mates securely with the inner surface of the upper axially aligned chamber 31 in a press-fitted relationship to secure the adapter member 30 to the tip assembly. The reservoir member 40, which is provided as a separate unit with the transfer tube 47 secured thereto, is removed from a sterile package and is filled to a predetermined extent according to the procedure with a supply of aqueous pigment solution. The stainless steel wire 60 is then inserted into the reservoir so that the portion 61 extends within the transfer tube 47 and the reservoir 40 is closed by the cap 70. Alternatively, the wire 60 may be inserted prior to filling the reservoir 40 with a pigment solution. Then, the closed reservoir container 40 containing the metering tube 47 with the agitating wire 60 therein is inserted into the obliquely aligned chamber 36 on the adapter member 30 to form the structure shown in Fig. 3 and the aqueous pigment solution meters down the transfer tube 47 and the transfer conduit 38 and then to the tip assembly 12 to the conical chamber 34 then to wet the needle 13 by capillary action.

Preferably, the angle of inclination of the obliquely inclined chamber 36, and thus the angle of inclination of the reservoir 40 relative to the vertically aligned tip assembly, is approximately 45 degrees.

- 11 -

After the procedure is completed, the reservoir may be removed and discarded. Alternatively, both the adapter member 30 and the reservoir member 40 may be removed and discarded.

5 Preferably, the adapter member 30, the reservoir 40 with the tip 47, the cap 70, and the wire 60 are provided as a part of a sterile disposable pack provided to the practitioner of the process of pigmentation described.

10 This invention may be embodied in other specific forms without departing from its spirit or essential characteristics. The present embodiments are, therefore, to be considered in all respects as illustrative and not restrictive, the scope of the invention being indicated by
15 the claims rather than by the foregoing description, and all changes which come within the meaning and range of the equivalents of the claims are therefore intended to be embraced therein.

- 12 -

1 WHAT IS CLAIMED IS:

2 1. For use with an apparatus of the type which
3 comprises a tip member for placing pigment in the dermis
4 of a patient by reciprocating a needle, an adapter member
5 comprising:

6 a housing defining an axially aligned chamber
7 and an inclined chamber, said inclined chamber having a
8 lower portion which communicates with a lower portion of
9 said axially aligned chamber for receiving pigment
10 solution therein, said axially aligned chamber
11 defining an upper portion structurally adapted to be
12 secured to a portion of said tip member so that the needle
13 projects from the lowermost portion of the axially aligned
14 chamber a predetermined distance, said inclined chamber
15 being structurally adapted to replaceably receive in a
16 first portion thereof a reservoir member containing a
17 pigment suspension therein and cooperating therewith to
18 transfer said pigment suspension from the lower portion of
19 said inclined chamber to the lower portion of said axially
20 aligned chamber to wet said needle with said pigment
21 suspension.

22 2. The apparatus as set forth in claim 1,
23 wherein the angle of inclination of said inclined chamber
24 relative to said axially aligned chamber is about 45
25 degrees.

26
27 3. The apparatus as set forth in claim 1
28 further including a reservoir member defining an outer
29 chamber for receiving said pigment suspension therein; and
30 a transfer tube having a predetermined inside
31 diameter for transferring said pigment suspension from
32 said outer chamber of said reservoir member through an
33 inner portion of said inclined chamber to the lower
34 portion in said body of said adapter member.

- 13 -

1 4. The apparatus as set forth in claim 3
2 further including a cap for securing said
3 pigment-receiving outer chamber of said reservoir member
4 when said pigment suspension has been provided therein.

5
6 5. The apparatus as set forth in claim 3,
7 wherein said reservoir member further includes control
8 means cooperating with said transfer tube to control the
9 rate of metering of said pigment suspension from said
10 pigment-receiving outer chamber and for agitating said
11 pigment suspension when said needle is reciprocated.

12
13 6. The apparatus as set forth in claim 5,
14 wherein said control means includes a wire having a first
15 portion inserted in said transfer tube and a second
16 inclined portion located in said outer chamber of said
17 reservoir member.

18
19 7. The apparatus as set forth in claim 6,
20 wherein the annular space defined by the inside diameter
21 of said transfer tube and the outside diameter of said
22 wire is sized to meter said pigment solution from said
23 pigment-receiving outer chamber of said reservoir member
24 to said needle during an implantation procedure.

25
26 8. In combination:
27 means for implanting pigment in the dermis of a
28 patient comprising a needle secured to a tip assembly
29 which in turn is secured to a reciprocating head attached
30 to a drive unit for reciprocating said needle to implant
31 pigment in the dermis of a patient during an implantation
32 procedure;

33 an adapter member secured to a portion of said
34 tip assembly and defining therein an axially oriented
35 first chamber for receiving therein said tip assembly and

- 14 -

1 said needle so that said needle protrudes from the lower
2 surface of said adapter member a predetermined distance to
3 control the depth of implantation in said dermis;

4 said adapter member further defining an
5 obliquely inclined chamber for receiving therein a
6 reservoir member having means for transferring an aqueous
7 pigment suspension in said reservoir member to said
8 axially aligned first chamber to wet said needle with said
9 aqueous solution;

10 a reservoir member secured in said obliquely
11 inclined chamber for controlling dispensing a pigment
12 solution from said reservoir member by a metering means to
13 said axially aligned chamber at a controlled rate; and

14 means for agitating the aqueous pigment
15 suspension within said reservoir member during said
16 procedure.

17

18

19 9. The combination as set forth in claim 7,
20 wherein said metering means includes a transfer tube
21 connected to a pigment-receiving chamber in said reservoir
22 member and extending toward a lower portion of said
23 axially aligned chamber.

24

25 10. The combination as set forth in claim 9,
26 wherein agitating means cooperate with said transfer tube
27 and said pigment-receiving chamber in said reservoir
28 member.

29

30 11. The combination as set forth in claim 10,
31 wherein said agitating means is a weighted wire having a
32 linear portion axially-extending in a portion of said
33 transfer tube and another portion located in said
34 pigment-receiving chamber in said reservoir member.

- 15 -

1 12. The apparatus as set forth in claim 11,
2 wherein the annular space defined by the inside diameter
3 of said transfer tube and the outside diameter of said
4 wire is sized to meter said pigment suspension from said
5 pigment-receiving outer chamber of said reservoir member
6 to said needle during an implantation procedure.

7

8 13. In combination:

9 a reservoir member, at least a portion of which
10 is structurally adapted to be securely received in a
11 complementary opening in a tip member of an apparatus for
12 placing pigment in the dermis of a patient by
13 reciprocating a needle, said reservoir member defining an
14 outer chamber for receiving a pigment suspension therein;

15 a transfer tube communicating with said
16 pigment-receiving chamber of said reservoir for
17 transferring pigment therefrom to a chamber in said tip
18 member; and

19 means for agitating the pigment suspension in
20 said reservoir chamber, said agitating means being
21 operative when said tip member is reciprocated, said
22 agitating means comprising a wire cooperating with both
23 said transfer tube and said pigment-receiving chamber.

24

25 14. The apparatus as set forth in claim 13,
26 wherein said agitating means is a weighted wire having a
27 linear portion axially-extending in a portion of said
28 transfer tube and another portion located in said
29 pigment-receiving chamber in said reservoir member.

30

31 15. The apparatus as set forth in claim 14,
32 wherein the annular space defined by the inside diameter
33 of said transfer tube and the outside diameter of said
34 wire are sized to meter said pigment solution from said
35 pigment-receiving outer chamber of said reservoir member
36 to said needle during an implantation procedure.

- 16 -

1 16. A method of controlling the dispensing of a
2 pigment suspension to a needle in a device of the type
3 comprising a reciprocating tip member for placing pigment
4 in the dermis of a patient by reciprocating a needle,
5 comprising the steps of:

6 placing an adapter member on said tip member,
7 said adapter member cooperating, when so placed, with said
8 needle to control the penetration of said dermis, and
9 defining a pigment receiving chamber in the region of said
10 needle;

11 providing a reservoir having a supply of pigment
12 suspension in a chamber therein, said reservoir having a
13 transfer tube for causing a controlled dispensing of said
14 pigment from said chamber;

15 fixing said reservoir in a complementary chamber
16 of the adapter member, said complementary chamber defining
17 a fluid passage communicating with the region of said
18 needle in said adapter member, so that said transfer tube
19 is inserted in said passage; and

20 agitating said suspension with an agitating
21 member while reciprocating said needle to inhibit clogging
22 of said transfer tube.

23
24 17. The method as set forth in claim 16,
25 wherein the step of agitating is carried out by placing a
26 shaped wire in said pigment receiving chamber so that a
27 portion of said wire is located in said transfer tube, and
28 another portion of said wire is located in said reservoir.

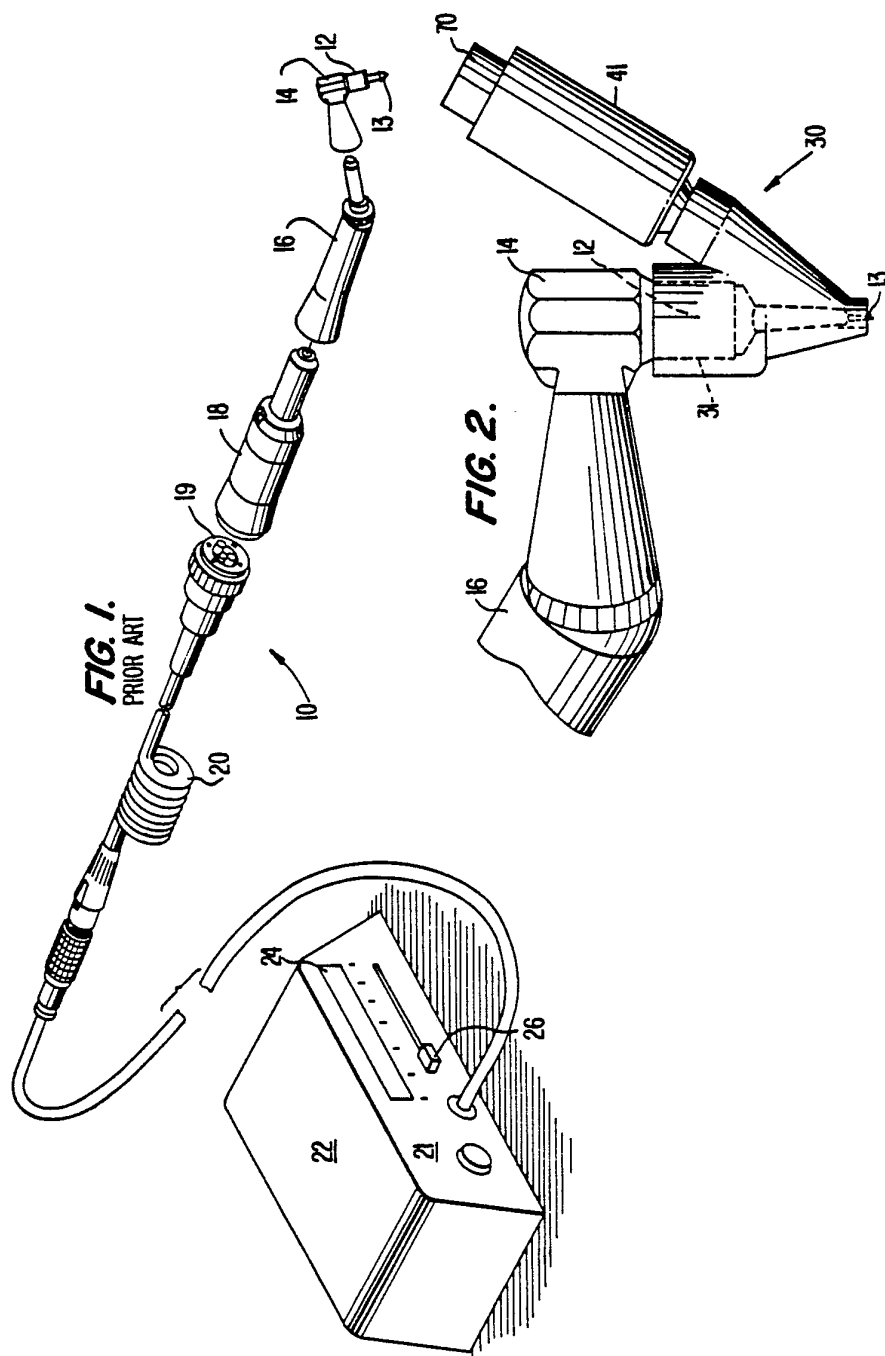
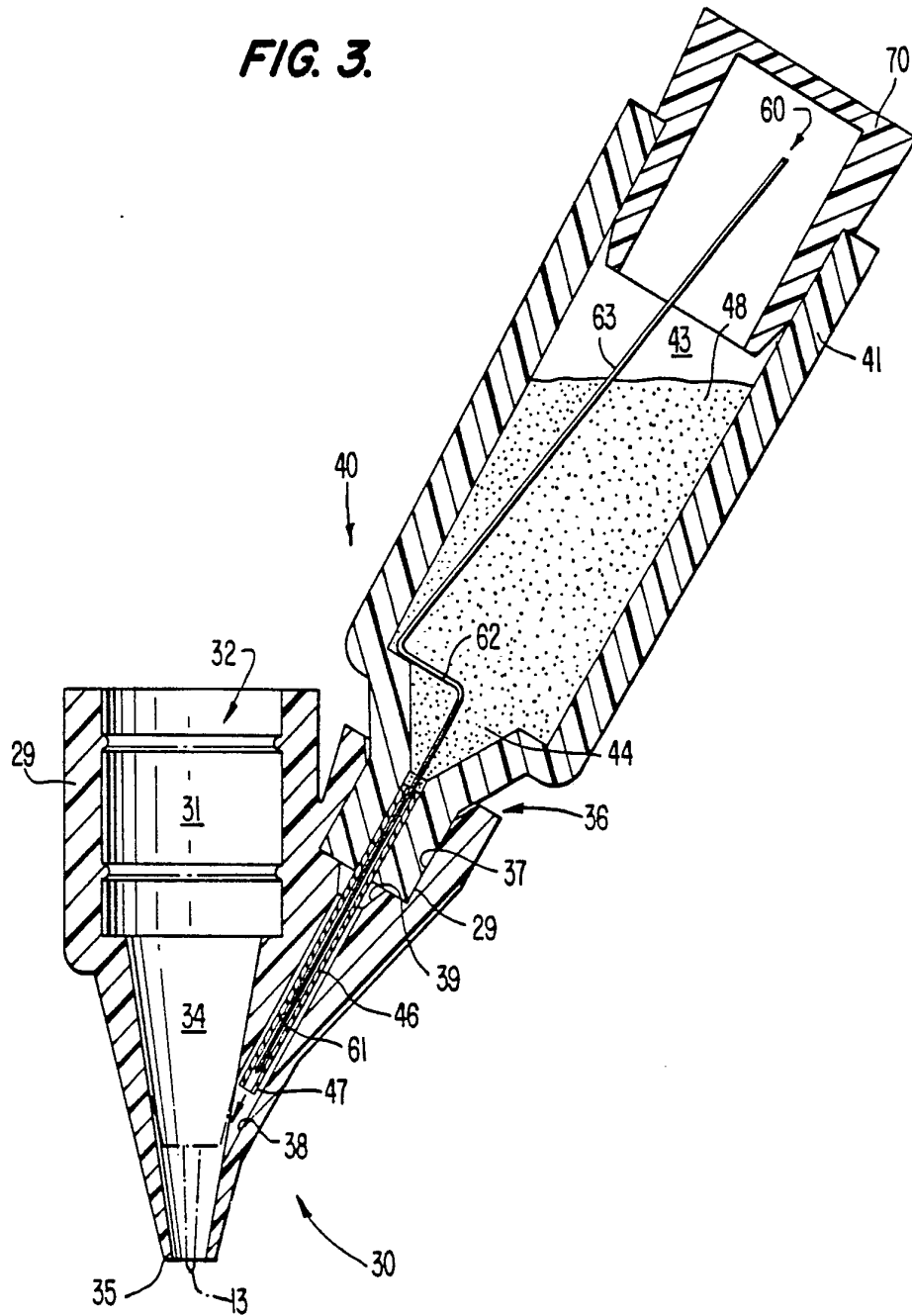

FIG. 3.



INTERNATIONAL SEARCH REPORT

International Application No PCT/US86/01411

I. CLASSIFICATION OF SUBJECT MATTER (if several classification symbols apply, indicate all) ³		
According to International Patent Classification (IPC) or to both National Classification and IPC		
IPC (4) B 43 K 5/00		
II. FIELDS SEARCHED		
Minimum Documentation Searched ⁴		
Classification System	Classification Symbols	
US	81/9.22 128/316	132/88.5 88.7
Documentation Searched other than Minimum Documentation to the Extent that such Documents are Included in the Fields Searched ⁵		
III. DOCUMENTS CONSIDERED TO BE RELEVANT ¹⁴		
Category [*]	Citation of Document, ¹⁶ with indication, where appropriate, of the relevant passages ¹⁷	Relevant to Claim No. ¹⁸
X	US, A 3,535,048 (Bok) 20 October 1970 See the entire document	13-15
X	US, A 3,994,293 (Ferro) 30 November 1976 See the entire document	1-5
A	US, A 4,508,106 (Angres) 2 April 1985 See the entire document	1-17
<p>[*] Special categories of cited documents: ¹⁵</p> <p>"A" document defining the general state of the art which is not considered to be of particular relevance</p> <p>"E" earlier document but published on or after the international filing date</p> <p>"L" document which may throw doubts on priority claim(s) or which is cited to establish the publication date of another citation or other special reason (as specified)</p> <p>"O" document referring to an oral disclosure, use, exhibition or other means</p> <p>"P" document published prior to the international filing date but later than the priority date claimed</p> <p>"T" later document published after the international filing date or priority date and not in conflict with the application but cited to understand the principle or theory underlying the invention</p> <p>"X" document of particular relevance; the claimed invention cannot be considered novel or cannot be considered to involve an inventive step</p> <p>"Y" document of particular relevance; the claimed invention cannot be considered to involve an inventive step when the document is combined with one or more other such documents, such combination being obvious to a person skilled in the art.</p> <p>"&" document member of the same patent family</p>		
IV. CERTIFICATION		
Date of the Actual Completion of the International Search ²	Date of Mailing of this International Search Report ²	
19 August 1986	24 SEP 1986	
International Searching Authority ¹	Signature of Authorized Officer ²⁰	
ISA/US	Carroll Dority	