

[54] PLASTIC BAG CONSTRUCTION

[76] Inventor: Eugene P. Christie, Park Ridge, Ill.

[22] Filed: Oct. 12, 1971

[21] Appl. No.: 188,142

[52] U.S. Cl. .... 229/62, 229/54 R

[51] Int. Cl. .... B65d 33/16

[58] Field of Search ..... 229/62, 54 R; 150/3

[56] References Cited

UNITED STATES PATENTS

3,217,971	11/1965	Shretz .....	229/62
3,326,449	6/1967	Dickson .....	229/62
3,480,198	11/1969	Repko .....	229/62 X

Primary Examiner—George E. Lowrance

Assistant Examiner—Stephen P. Garbe

Attorney—Roy H. Olson et al.

[57] ABSTRACT

An embodiment of the invention disclosed herein comprises a plastic bag construction having tie portions formed as an integral part of the bag which are used to close the top of the bag when filled. The bag is formed of a flattened flexible plastic tube having front and back panels and folded in portions extending along the side edges of the panels. A weld is formed along the bottom edges of the panels to close the bag and a weld is formed along the top edges of the panels to hold together the front and back panel portions which form the tie portions. A struck out portion is formed through the front and back panels near the top edges thereof and the material between the struck out portion and the top edges of the panels will form the integral tie portions.

7 Claims, 8 Drawing Figures

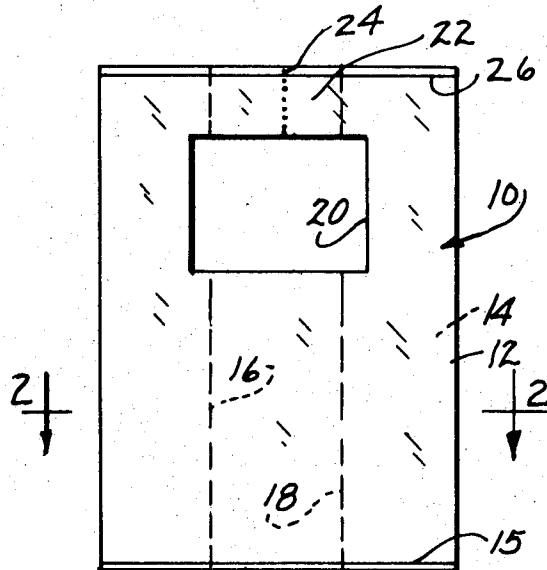

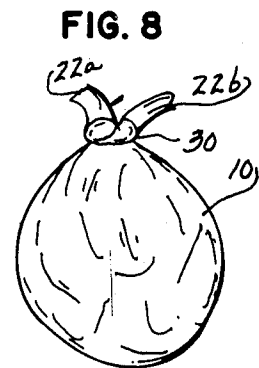
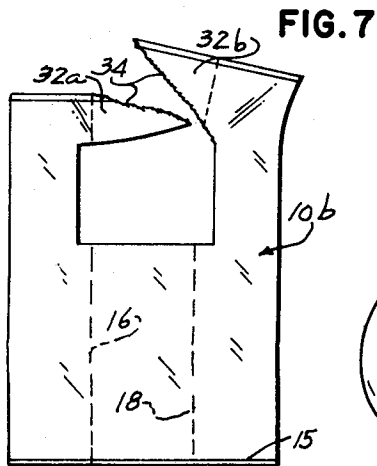
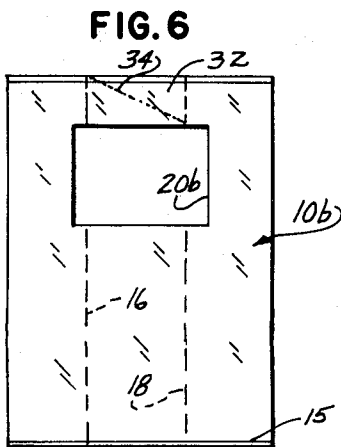
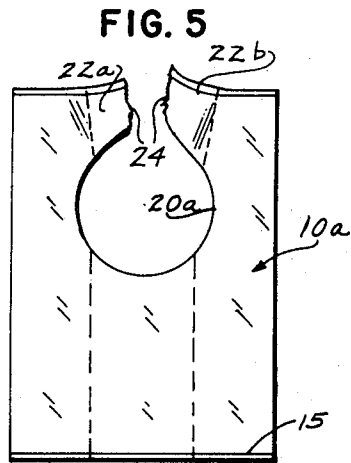
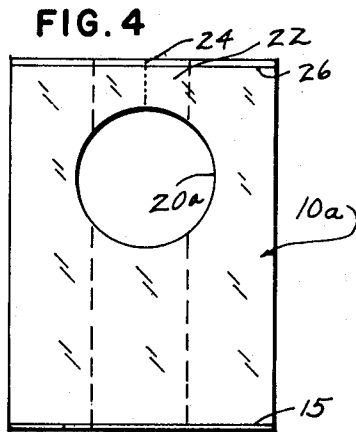
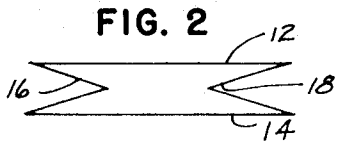
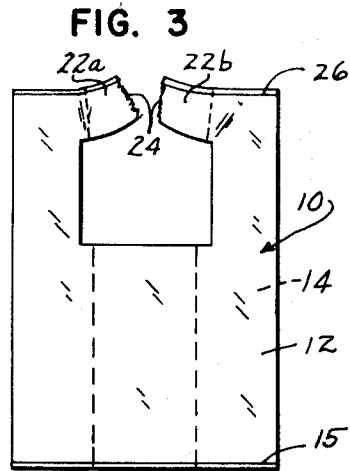
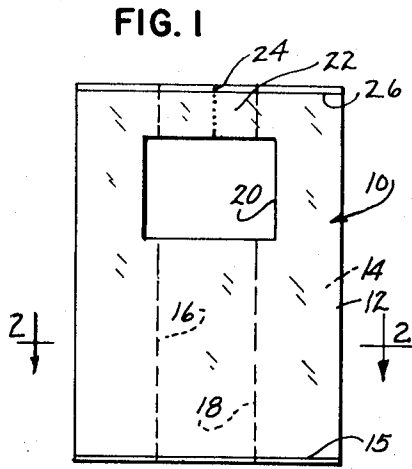

## PLASTIC BAG CONSTRUCTION

### BACKGROUND OF THE INVENTION

This invention relates generally to a bag construction and more particularly to a one piece plastic bag construction which has tie portions formed as an integral part thereof.

The use of plastic bags for refuse and storage of particular materials is becoming more prevalent. Such plastic bags provide a simple and inexpensive means for sealing the material contained therein against moisture and/or vermin such as rats. In many cities such plastic refuse bags are required to be used for the disposal of garbage. This was made necessary because of the large rat populations and it is attempted to reduce this large rat population by reducing or eliminating supply of garbage upon which the rats feed. When using plastic bags as garbage containers, they must be sealed or tied off at their upper ends to be effective.

Several prior art bags provide either tear-off portions formed on the bag to be used as a tie or they provide a wire tie which is either loosely supplied or removably fastened to the exterior of the plastic bag which is removed for tying the top end. While this type of tie is effective in initially closing off the bag, it becomes a questionable matter when, for some reason, the bag is to be reopened and again sealed. When this is the case, many times the tie will become broken or lost and subsequent closing of the bag cannot be accomplished. In this instance rodent control is defeated.

### SUMMARY OF THE INVENTION

Accordingly, it is an object of this invention to provide an improved plastic bag for use as a refuse bag which has tie portions formed as an integral part of the bag to tie off the top end thereof.

Another object of this invention is to provide an improved plastic bag which has tie portions extending along the top edge of the bag from side to side the full width thereof but which, when separated to form the tie, will have a total length which is greater than the width of the bag.

A feature of the bag construction of this invention is that a struck out portion at the top end of the bag not only forms the tie portions for the bag but also passes through the side folded in portions of the bag panels to form carrying handles for the bag.

Other objects, features and advantages will become more fully apparent from the following detailed description when taken in conjunction with the accompanying drawings wherein like reference numerals throughout the various views of the drawings are intended to designate similar elements or components.

### BRIEF DESCRIPTION OF THE DRAWINGS

FIG. 1 is a plan view of one form of bag construction in accordance with this invention;

FIG. 2 is a sectional view of the bag of FIG. 1 taken along line 2—2;

FIG. 3 illustrates the bag of FIG. 1 with the tie portions separated;

FIG. 4 is a plan view of an alternate bag construction in accordance with this invention;

FIG. 5 is the bag of FIG. 1 shown with the tie portions separated;

FIG. 6 is a plan view of still another alternate form of bag construction in accordance with this invention

which has tie portions having an effective length greater than the width of the bag;

FIG. 7 shows the bag of FIG. 6 with the tie portions separated; and

FIG. 8 shows a bag of the invention with an upper end thereof tied off and sealed.

### DETAILED DESCRIPTION OF THE ILLUSTRATED EMBODIMENTS

Referring now to FIG. 1, a bag construction of this invention is illustrated and designated generally by reference numeral 10. The bag 10 is formed of a flattened flexible plastic tube of any suitable material such as, for example, polyethylene. The plastic material forming the bag is to be readily heat sealable to facilitate mass production with conventional equipment.

The bag 10 has front and back panels 12 and 14, respectively, which are heat sealed together along their bottom edges by a weld 15. Folded in portions 16 and 18 are provided to increase the volume of the bag when used, as best seen in FIG. 2. A struck out portion 20 is formed at the upper end of the bag slightly spaced from the top edges thereof to form a tie portion 22. In this instance the tie portion 22 has a tear line 24 formed substantially parallel to the longitudinal axis of the bag. Also, the struck out portion 20 has a transverse extent sufficient to engage with and cut through the innermost edges of the folded in portions 16 and 18 to thereby form handles for the bag in a manner to be described.

A weld 26 is formed across the top edges of the bag to seal together the front and back panel portions which are used to form the tie portion 22. Therefore, the welded condition of the upper end of the bag together with the cut through condition of the folded in portions 16 and 18 form the carrying handles of the bag to facilitate transporting a filled bag prior to tying off the upper end thereof.

The bag 10, as seen in FIG. 3, has the upper tie portion 22 thereof separated into two tie portions 22a and 22b. These tie portions are then readily manually manipulated to close the bag by a knot 30, as best seen in FIG. 8.

FIGS. 4 and 5 illustrate an alternate form of bag construction and is designated generally by reference numeral 10a. Here the struck out portion 20 is circular in configuration and is designated by reference numeral 20a. The struck out portion 20a also has a maximum transverse extent sufficient to cut through the folded in portions of the bag to form carrying handles for the bag. The tie portion 22 is severable along the tear line 24 in the same manner as the bag 10 of FIG. 1 and is shown in this severed condition in FIG. 5.

Referring to FIGS. 6 and 7, still another form of bag construction is shown and designated by reference numeral 10b. Here the struck out portion 20b is rectangular in configuration and passes through the folded in portions 16 and 18 to form carrying handles as mentioned above. Most advantageously, a tie portion 32 is formed at the upper end of the bag and has a diagonally displaced tear line 34 formed substantially centrally of the tie portion 32. When the tie portion 32 is severed, as shown in FIG. 7, the two tie ends 32a and 32b, because of the diagonal sever line, will have a total length which is greater than the width of the bag. This feature provides longer tie portions to facilitate tying off the bag, which is most useful for closing off bags of smaller size.

What has been described is a simple bag construction wherein tie portions are formed as an integral part of the bag and which tie portions can be formed to have an effective length greater than the width of the bag which forms the tie portions. Although only three embodiments of this invention are illustrated herein, it will be understood that variations and modifications may be effected without departing from the spirit and scope of the novel concepts disclosed and claimed herein.

The invention is claimed as follows:

1. A bag construction composed of weldable sheet material in the form of a flattened flexible plastic tube having front and back panels and folded in portions extending along the side edge of said panels, a weld formed along the bottom edges of said panels and said folded in portions to form a closed bottom for the bag, a struck out portion through both front and back panels near the top edges thereof but spaced therefrom sufficient to form a tie portion extending across the top of the bag, said struck out portion passing through the innermost portions of said folded in portions to form diametrically opposed handles for the bag, and a tear line formed through said tie portion to allow pulling apart thereof into two lengths to be tied together for closing off the top of the bag so formed.

2. The bag construction of claim 1 further including a weld formed along the top edges of said front and back panels and said folded in portions to hold together the front and back panel portions forming said tie portion.

3. The bag construction of claim 1 wherein said struck out portion is rectangular in configuration.

4. The bag construction of claim 1 wherein said struck out portion is circular in configuration.

5. The bag construction of claim 1 wherein said tear line is parallel to the longitudinal axis of said bag.

6. The bag construction of claim 1 wherein said tear line is transverse to the longitudinal axis of said bag to provide two tie portions having a total effective length greater than the width of the bag.

7. The bag construction of claim 1 further including a weld formed along the top edges of said front and back panels and said folded in portions to hold together the front and back portions forming said tie portion, said struck out portion passing through the innermost portions of said folded in portions to form handles, and said tear line is transverse to the longitudinal axis of said bag to provide two tie portions having a total effective length greater than the width of the bag.

\* \* \* \* \*

30

35

40

45

50

55

60

65