



INTERNATIONAL APPLICATION PUBLISHED UNDER THE PATENT COOPERATION TREATY (PCT)

<p>(51) International Patent Classification <sup>6</sup> : <b>G06F 17/21</b></p>	<p><b>A1</b></p>	<p>(11) International Publication Number: <b>WO 97/22066</b> (43) International Publication Date: 19 June 1997 (19.06.97)</p>
<p>(21) International Application Number: PCT/US96/20879 (22) International Filing Date: 13 December 1996 (13.12.96) (30) Priority Data: 60/009,290 15 December 1995 (15.12.95) US (71) Applicant (for all designated States except US): THE SOFT-PAGES, INC. [US/US]; Suite 201, 383 West Drake Road, Fort Collins, CO 80526 (US). (72) Inventor; and (75) Inventor/Applicant (for US only): HOPKINS, Daniel, Richard [US/US]; 1030 Wagonwheel Drive, Fort Collins, CO 80526 (US). (74) Agent: FISHMAN, Daniel, Nathan; Suite 201, 1136 Pearl Street, Boulder, CO 80302-5141 (US).</p>	<p>(81) Designated States: AL, AM, AT, AU, AZ, BB, BG, BR, BY, CA, CH, CN, CZ, DE, DK, EE, ES, FI, GB, GE, HU, IL, IS, JP, KE, KG, KP, KR, KZ, LK, LR, LS, LT, LU, LV, MD, MG, MK, MN, MW, MX, NO, NZ, PL, PT, RO, RU, SD, SE, SG, SI, SK, TJ, TM, TR, TT, UA, UG, US, UZ, VN, ARIPO patent (KE, LS, MW, SD, SZ, UG), Eurasian patent (AM, AZ, BY, KG, KZ, MD, RU, TJ, TM), European patent (AT, BE, CH, DE, DK, ES, FI, FR, GB, GR, IE, IT, LU, MC, NL, PT, SE), OAPI patent (BF, BJ, CF, CG, CI, CM, GA, GN, ML, MR, NE, SN, TD, TG).</p> <p><b>Published</b> With international search report. Before the expiration of the time limit for amending the claims and to be republished in the event of the receipt of amendments.</p>	

(54) Title: METHOD FOR COMPUTER AIDED ADVERTISEMENT

(57) Abstract

A computer implemented method for presenting vendor advertising information to a user of a computer system (100). The advertising information (404, 406) is presented to the user as a multimedia presentation including text, graphics, audio, and video information. The advertising information is searchable by the user according to any of several indices (500) including: name (1110), address(1116), phone number (1122), location (1010), category of commerce (1312), etc. Vendors may select a locked, preferred position for their advertising information. Additionally, vendors may select to lock their position by alphanumeric sorting (500) with other vendors in the selected geographic area and/or category of commerce. Otherwise, all non-fixed position ads in a particular category of commerce are rotated each time the corresponding category is selected by the user. The method facilitates selection of a vendor nearest the user's location (1016). Keying information is maintained to account for the usage of each advertisement on each user's computer system for reporting to the vendors. An HTML document and an associated browser program, implemented on the user's computer system, are used to implement the method.

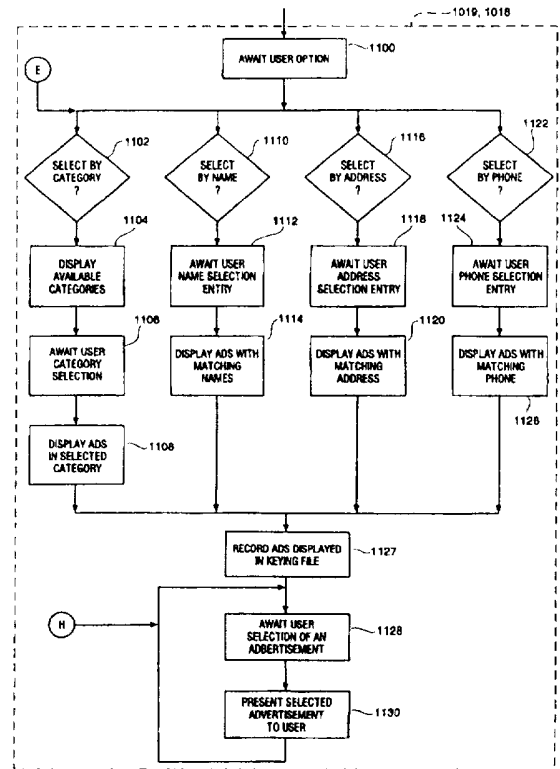

**FOR THE PURPOSES OF INFORMATION ONLY**

Codes used to identify States party to the PCT on the front pages of pamphlets publishing international applications under the PCT.

AM	Armenia	GB	United Kingdom	MW	Malawi
AT	Austria	GE	Georgia	MX	Mexico
AU	Australia	GN	Guinea	NE	Niger
BB	Barbados	GR	Greece	NL	Netherlands
BE	Belgium	HU	Hungary	NO	Norway
BF	Burkina Faso	IE	Ireland	NZ	New Zealand
BG	Bulgaria	IT	Italy	PL	Poland
BJ	Benin	JP	Japan	PT	Portugal
BR	Brazil	KE	Kenya	RO	Romania
BY	Belarus	KG	Kyrgystan	RU	Russian Federation
CA	Canada	KP	Democratic People's Republic of Korea	SD	Sudan
CF	Central African Republic	KR	Republic of Korea	SE	Sweden
CG	Congo	KZ	Kazakhstan	SG	Singapore
CH	Switzerland	LI	Liechtenstein	SI	Slovenia
CI	Côte d'Ivoire	LK	Sri Lanka	SK	Slovakia
CM	Cameroon	LR	Liberia	SN	Senegal
CN	China	LT	Lithuania	SZ	Swaziland
CS	Czechoslovakia	LU	Luxembourg	TD	Chad
CZ	Czech Republic	LV	Latvia	TG	Togo
DE	Germany	MC	Monaco	TJ	Tajikistan
DK	Denmark	MD	Republic of Moldova	TT	Trinidad and Tobago
EE	Estonia	MG	Madagascar	UA	Ukraine
ES	Spain	ML	Mali	UG	Uganda
FI	Finland	MN	Mongolia	US	United States of America
FR	France	MR	Mauritania	UZ	Uzbekistan
GA	Gabon			VN	Viet Nam

## METHOD FOR COMPUTER AIDED ADVERTISEMENT

### Field of the Invention

5 The present invention relates to advertising medium and methods and in particular to computer operable methods for presenting multimedia advertisements regarding client/advertiser activities to a user of a computer operating in accordance with the methods of the present invention.

### Problem

10 Advertising media are selected for their suitability in particular styles or areas of commerce. For example, in some areas of commerce, simple textual presentation of information about a business may suffice, whereas in other areas of commerce, audio and/or video information presentation style may be required to convey a particular message regarding a business. It is also common in directories of such  
15 advertising to index the advertisements of the participating merchants to aid the user of the directory in locating the information. For example, so-called "White Pages" phone directories are indexed by name only, while so-called "Yellow Pages" phone directories are indexed by category first, then by name second. Other aspects of business advertising attempt to target the audience by geography or other demographic  
20 information. For example, direct mail advertisements typically focus the advertising on a particular geographic area.

Current advertisement media and techniques all suffer from one or more problems. Some advertising media are incapable of storing and presenting a large volume of advertisements or a large volume of data in a particular advertisement. To  
25 provide for and present such large volumes may be too costly under some advertising techniques using some advertising media. Some advertising techniques and media severely limit the manner in which a user may search the voluminous advertisements. For example, telephone books do not index the advertisers by geographic location. Or for example, other media may not index the advertisers by categories of commerce.  
30 Most advertising techniques and media are limited in their variety of presentation styles. For example, television advertisements are not searchable by indices, telephone directories are incapable of presenting audio or visual information, radio

advertising cannot present video information, etc.

In view of the above discussion it is clear that a need exists for an advertising medium and method which combines features of other mediums to permit large volumes of advertising information, comprised of any of several styles of presentation data. Further a need exists for the advertisements to be searchable by any of several indices, and to be rapidly and frequently updated.

### Solution

The present invention solves the above and other problems, thereby advancing the useful arts, by providing computer operable methods and associated apparatus for computer aided advertising. The present invention includes computer data structures for storing and structuring advertising information and computer operable methods for manipulating and presenting the structured advertising information on a standard personal computer (with or without multimedia functionality). The advertising information includes information constructed in any of several medium and presentation styles, including: audio, video, text, graphics, etc. The advertising information is searchable by any of several indices, including: alphabetically by name, by address, by business/commerce categories, etc. The advertising information may include coupons for special promotional offers. Associated computer operable methods help assure that the coupons may be printed and used only a predetermined, fixed number of times. The advertising information and associated methods include features which generate a graphical map and textual directions to the corresponding vendors establishment from the user's starting point (user's location and address). The advertising information may be stored on CDROM medium and physically delivered to prospective customers or may reside on nodes of local (or national) computing networks for access via computer to computer communications. In either case, large volumes of advertising information may be inexpensively delivered to prospective customers and may be easily and frequently updated. Certain preferred positions and timing of the advertising information presentation may be used by vendors to provide the user with more noticeable, unsolicited, advertising information. For example, a

portion of the user's computer screen may be dedicated to a continuous "ticker" advertisement or the "title" screen when the program is started may present a preferred vendor's advertisement. The first advertisement presented to a user in response to a commerce category search may be a preferred position at which a vendor may elect to lock their presentation. A vendor may elect to lock their presentation by a fixed alphanumeric ordering within a particular category. And finally, other advertisements in a commerce category will simply have their vendor names listed in alphabetical order. Those vendors with standard position advertisements will be highlighted in the alphabetical listing of other vendors. In an alternative embodiment, the vendors having standard position ads may have their ads displayed to the extent space remains on the display following presentation of preferred position ads and reserving space for an alphabetical listing. It will be common that more standard position ads are present in a category than may be simultaneously presented on the display. The subset of standard ads selected for display each time a category is selected is therefore rotated each time the category is accessed to provide fair access by customers to the other vendors advertisements.

In particular, the present invention may be embodied as a standard computer application program which presents the user with menu options to search, select, and receive the desired advertising information presentation. Such programming techniques are well known to those of ordinary skill in the software arts. In addition, such menu oriented user interfaces are typical in common computing environments such as Microsoft® Windows® or the Apple Macintosh®. In the best presently known preferred embodiment, the present invention may be implemented as a Hypertext document written in the Hypertext Markup Language (HTML). The HTML document describes the structure and interrelation of the various components of the advertising information as well as encoding the actual advertising data itself. An HTML document includes information content as well as structure which directs the browser to other related information in a manner analogous to hierarchical menus common in the Windows® programming environment noted above. The information content may be textual, graphical, audio, or video in its style of presentation. The HTML document is

then "viewed" (i.e. the information content is presented to the user) by any of several well known, commercially available, browser programs. Exemplary of such "Web browser" programs are Netscape™ and Mosaic™ which are well known by, and readily available to, those of ordinary skill in the art. The browser program includes capabilities to present any such presentation styles to the user (assuming appropriate computer accessories are attached to the computer).

The HTML document may be distributed to prospective users on CDROM media so as to provide large volumes of advertising data to users inexpensively. A single CDROM may contain the advertising data for a particular city or town. The browser program is simply directed to browse the HTML document stored on the CDROM. All other advertising information is then stored on the CDROM and accessible through the structures and operations coded in the root HTML document. In addition, the HTML document may be browsed by access to computer networks as is well known to those of ordinary skill in the art. The HTML document may simply be located at a node in the computer network and reviewed by the user by directing the browser program to the location which stores the HTML document. Such network browser capabilities are well known to those of ordinary skill in the art. Commercial examples of such network browsing capabilities include, for example, browsing "home pages" (HTML documents) on the so-called World Wide Web (also referred to as "the Web" or simply "WWW") as available on Internet or, for example, browsing titles published on the Microsoft Network (MSN). Programs and other tools used in construction and browsing of such HTML documents are readily available in commerce and well known to those of ordinary skill in the art.

The above improvements and other objects, aspects, features, and advantages of the present invention will become apparent from the following description and the attached drawing.

#### **Brief Description of the Drawing**

FIG. 1 is a block diagram of a typical computing environment in which the methods of the present invention may be operated;

FIG. 2 is a block diagram showing additional details of the user's computer shown in FIG. 1;

FIG. 3 is exemplary of the opening image as seen on the display of the computer system when the methods of the present invention are initiated;

5           FIG. 4 is exemplary of an image as seen on the display of the computer system wherein the methods of the present invention permit selection of advertising material based upon commerce categories and alphabetical index;

10           FIG. 5 is exemplary of an image as seen on the display of the computer system wherein the methods of the present invention display advertisements located for a particular commerce area - namely attorneys;

FIG. 6 is exemplary of an image as seen on the display of the computer system wherein the methods of the present invention provide additional detail as to the advertised information for a selected vendor;

15           FIG. 7 is exemplary of an image as seen on the display of the computer system wherein the methods of the present invention present special offer coupons provided by the selected vendor;

20           FIG. 8 is exemplary of an image as seen on the display of the computer system wherein the methods of the present invention generates a map and associated textual directions from the user's location to the selected vendor's location;

FIG. 9 shows the structure of vendor advertising information stored on CDROM or in a central database;

FIG. 10 is a flowchart describing the highest level of processing of the methods of the present invention from program startup;

25           FIG. 11 is a flowchart describing additional detail of the user directed search of an area or online directory as shown in FIG. 10;

FIG. 12 is a flowchart describing additional detail of the presentation of information regarding a selected vendor as shown in FIG. 11;

30           FIG. 13 is a flowchart describing the methods of processing toolbar or menu bar functions requested by the user at any time in the processing of the methods of FIGS.

10-12; and

FIG. 14 is exemplary of the title page on which a vendor may elect to lock their advertisement for increased exposure.

5                                   **Detailed Description of the Preferred Embodiment**

While the invention is susceptible to various modifications and alternative forms, a specific embodiment thereof has been shown by way of example in the drawings and will herein be described in detail. It should be understood, however, that it is not intended to limit the invention to the particular form disclosed, but on the contrary, the invention is to cover all modifications, equivalents, and alternatives falling within the spirit and scope of the invention as defined by the appended claims.

**COMPUTER ASSISTED MULTIMEDIA ADVERTISING:**

The present invention includes methods and data structures operable within a computing system for presenting multimedia advertising information for a plurality of vendors to a user of the computer system. The present invention further includes data structures which permit the advertising information to be searched according to any of several indices. A user may select a particular one of the plurality of vendors for presentation of the corresponding advertising information. The advertising information may include, for example, text, graphics, and video information for presentation on the computer system's display device as well as audio information for presentation on the computer system's speakers.

In addition to indexing the advertising information based upon the vendors' names, addresses, and phone numbers, the advertising information is searchable by geographic areas (such as by town or by sections of a city) and by category of commerce. Special groupings of vendors are identified for governmental agencies, community services, or local emergency information. The geographic information regarding the vendor and the user of the present invention (entered at installation and setup of the present invention) are used to permit selection of a nearest vendor in a particular business category or geographic area.



The advertising information may be stored on a CDROM disk and distributed to potential customers in the appropriate marketplace or may be accessed via computer network communications with a centrally managed database of all subscribing areas and categories. As discussed below, the term database as used herein refers to the collection of advertising information and its associated data structures utilized in searching the advertising information. The actual implementation of such a database is a matter of design choice and may include a traditional database structure managed by a commercial database management system as well as a collection of structured Hypertext Markup Language (HTML) documents. The HTML documents may be considered a database as the term is utilized herein in the sense that they contain both the advertising information and associated data structures utilized in searching the advertising information.

In addition to presentation of vendor advertising information, the present system includes features to generate a graphical map and associated textual directions to the vendors location from the user's location. Other information includes special promotional offers (such as coupons) which may be printed by the user for redemption at the vendor's location. The number of times a coupon may be printed may be limited to a fixed number if so desired by the vendor.

FIG. 1 is a block diagram of an exemplary computing environment in which the methods and structures of the present invention may be utilized. A user's computer 100 may include a CDROM drive 106 for selecting and receiving multimedia vendor advertising information stored on CDROM media. In addition, user computer 100 may include a modem 108 which may be used in the methods of the present invention to connect the user's computer 100 directly to the vendor's computer 102 via telephone line 114 and modem 110 attached to the vendor's computer 102. Additionally, user's computer 100 may be attached to network 112 to a vendor's computer 102 or to a service provider's computer 104 at which resides a central database 116 containing all subscribing vendors' multimedia advertisements.

A user at computer 100 selects advertisements from the CDROM media in CDROM drive 106 or from the central database over network 112 for vendors which

provide desired goods or services. The vendors may be selected by any of several indices (discussed below in additional detail). When a user identifies a desired advertisement, the user selects the advertisement for presentation of the corresponding multimedia information stored on the CDROM or the central database. Other detailed information may then be requested by the user including special promotional offers (coupons if available from the vendor) as well as graphic maps and textual directions to the selected vendor's location.

FIG. 2 provides additional detail of the architecture of a user computer system 100 in which the methods of the present invention may be implemented. CPU 200 is connected to ROM memory 202 for storage of programmed instructions and RAM memory 202 for storage of program instructions and data. Keyboard 206 and pointer device (mouse) 208 are used to received user input commands and data to direct the selection and presentation of vendor advertisement information. Speakers 222 are used by CPU 200 to present audio information to the user. CPU 200 communicates with display interface 210, disk interface 212, modem 214, and network interface 216 via interface bus 224. Display 218 is used by CPU 200 via display interface 210 to present visual information to the user including, for example, text, graphics, animation, and full motion video. Disk 220 is used by CPU 200 via disk interface 212 to store data structures and program instructions for searching, selecting, and presenting advertising information for a particular vendor.

CDROM drive 106 is connected to CPU 200 through disk interface 212 and is used to permanently store the vendor advertising multimedia presentation information. Vendor advertising information may also be accessed from a central database maintained by the advertising service provider via network 112 via network interface 216. Modem 214 is used by CPU 200 to directly connect to a selected vendor's computer system for vendor specific processing or as an alternate connection path for access to the central database.

One of ordinary skill in the art will recognize that the computing environment represented in FIGS. 1 and 2 is exemplary of one computing environment capable of performing the methods of the present invention. Many equivalent computing

environments may be utilized to perform the methods of the present invention and to store the advertising information for selection by, and presentation to a user.

#### EXEMPLARY SCREEN DISPLAYS:

5           FIGS. 3-8 and 14 depict exemplary screen displays typical of the displays generated by the methods of the present invention operating on a computer system. One of ordinary skill in the art will readily recognize many equivalent graphical user interface styles, text, icons, etc. which may be utilized to perform the advertising search and presentation methods of the present invention.

10           There are a variety of advertising placements available under the methods of the present invention. For example, certain placements are preferred because they command more attention from a user or because they are presented more frequently. A vendor may therefore request that their advertisement be placed in such a preferred position. In the alternative, a vendor may place an ad but not request such preferred  
15 placement. Such a standard placement ad is therefore presented to the user in a position of less prominence than that of a preferred position ad. Further, a vendor may have no ad but rather a single line (or multiple line) textual listing to be displayed in an alphabetical list for a particular selected area or category of commerce.

20           Each ad therefore has a type attribute value associated with the advertising information to identify the type of the ad for placement purposes in the methods of the present invention. Exemplary attribute type include: preferred placement ad, standard placement ad, text listing, etc.

25           FIG. 14 is exemplary of the title page advertisement which is displayed each time the methods of the present invention are invoked on the user's computer system. A vendor may elect to present their advertising information at this preferred position to maximize exposure of their goods and services to the user. The title page advertising screen is displayed for a predetermined interval or until a user response is received to clear the screen and move on to normal operation of the methods of the present invention. Specifically, the user may strike any key on the keyboard or click the mouse  
30 device to cause the methods of the present invention to proceed to the opening screen

(discussed below).

FIG. 3 is exemplary of the opening screen of the present methods operating on a computer system. As on every exemplary screen discussed below, toolbar 300 contains iconic representations of commonly used functions in the operation of the methods of the present invention. Clicking the pointer device (mouse) on the iconic representation of a function invokes that function. Menu bar 302 provides a pull-down menu mode of access to the functions of the methods of the present invention. All functions available through the methods of the present invention are accessible via the pull-down menu operations of the menu bar. Functions such as the toolbar 300 and the menu bar 302 are well known to those of ordinary skill in the art of graphical user interface programming such as in the Microsoft Windows or Apple Macintosh computing environments. Further detail of the structure of the toolbar 300 and menu bar 302 need not be provided herein. The functions which are performed by the toolbar 300 and menu bar 302 are discussed below in additional detail with respect to the methods of the present invention.

The exemplary opening screen of FIG. 3 depicts iconic representations of the available directory areas in the database on the computer system. Depicted are directory areas for Fort Collins 304, Loveland 306, and Estes Park 308. The precise areas available on the local database are dependent upon the geographic areas served by the database. As discussed below, the database supplied to a user on a CDROM medium is subdivided as shown in FIG. 3 into geographic areas. The central database accessed via computer communication and networking techniques (as discussed below) provides advertising information for all geographic areas in which the service is provided. The user selects an advertising area by clicking the pointer device on the icon for the desired area (or alternatively by selecting the Phonebook menu bar pull-down menu). Once an area is so selected, a directory for that area is displayed on the user's screen. The opening screen title 310 identifies the provider of the advertising products and services of the present invention.

FIG. 4 depicts an exemplary display screen displayed by the methods of the present invention after an area has been selected. The screen suggests a closed

directory for the selected area (i.e. Fort Collins). Preferred position advertisements 404, 406, 408, and 410 for the selected area (Fort Collins) are displayed along with the closed directory cover 426. These preferred position advertisements are sold to vendors who choose to maximize their exposure to user's in the selected area.

5 In addition to the toolbar 300 and menu bar 302 (discussed above), the user is provided with index tabs A-Z 412 for viewing the area advertisements in alphabetical order by name. The user may "open" the closed directory for Fort Collins by clicking the pointer device on a desired first letter of the vendor's name (A-Z). In addition, the user is provided with category index tabs 414-424 to view a menu of commercial  
10 categories grouped by the supplied index tabs. For example, the user is provided a menu of business categories from which to select by clicking the pointer device on the Business index tab 414. Similarly, a menu of government categories is provided to the user by clicking the Gov't index tab 416, etc.

FIG. 5 depicts the directory for Fort Collins opened to the "Attorney" business  
15 category and in particular to the "A" index tab of attorneys. Mr. Armstrong and Mr. Aston are displayed on the open page 500 as the first two attorneys in the "A" index of the "Attorney" category of the Fort Collins directory. As noted above, preferred position advertisements 502 and 504 may be displayed regardless of the user's positioning of other normal advertisements according to the index searching methods. Additional  
20 pages of attorneys may be viewed by "turning" the pages of the directory. The pages may be turned by the page forward and page backward functions discussed below and accessible through related toolbar 300 icons, menu bar 302 functions, and keyboard or pointer device input from the user as is well known to those of ordinary skill in the art of graphical user interface programming.

25 A user may select an advertisement of particular interest from any display discussed above (as well as others not shown). An advertisement may be selected by simply clicking the pointer device on the desired advertisement. When an advertisement is so selected, a screen exemplified by FIG. 6 is displayed to provide the user with additional details of the selected vendor. Additional detail window 600 is  
30 presented to the user as a multimedia presentation. The presentation as discussed

above may include any combination of text, graphics, audio, and video information. Scroll bar 608 permits the user to easily view the entire content of the additional detail provided in window 600.

In addition to the multimedia detailed information presented in window 600, 5  
iconic buttons are provided for the user to simplify access to other common information for the selected vendor. Coupons button 602 provides the user with special promotional offers (if any) from the selected vendor. Autodial button 604 initiates processing to dial the vendor's voice phone number automatically through the user's computer. A data modem within the user's computer system (or other auto-dial 10  
equipment known to the telephony arts) may be used to dial the vendor's telephone. When the dialing process has completed, the computer system prompts the user to pick up the telephone receiver to commence discussions with the vendor. Directions button 606 generates and displays textual and graphical (map) directions to the vendor's location from the user's location (provided at registration of the program noted below). 15  
The network button 614 on the exemplary screen of FIG. 6 is used to connect the user's computer to the vendor's computer for direct computer interactions. The connection so established may be a direct modem link to the vendor's computer system or may be indirect through public data networks as is known to those of ordinary skill in the art. Finally, the E-mail button 612 is used to initiate processing to compose a message for 20  
the vendor and to direct the composed message to the vendor's E-mail address through standard computer communication and networking methods. The network button 614 and the E-mail button 612 may be utilized for computer data communications to, for example, retrieve vendor pricing or availability information, or, for example, to transmit order entry and processing data to the vendor's computing systems.

25 FIG. 7 depicts an exemplary screen showing the display of the selected vendor's promotional offer coupons. This screen is displayed at the user's request by clicking the Coupons button 602 of FIG. 6. One or more coupons 700 may be thus presented on the user's display. Close button 702 returns the user to the previous vendor detail screen (of FIG. 6) while the Print button 704 prints the selected coupon for redemption 30  
by the user. As noted below, options of the methods of the present invention permit the

vendor to specify a limit on the number of times each coupon displayed on the screen depicted in FIG. 7 may be printed. Log files written to the user's computer system record the number of times each coupon is printed and limit the printing if the vendor so desires.

5           FIG. 8 depicts an exemplary screen showing the display of graphical and textual direction to the vendor's location from the user's location. This screen is displayed in response to the user's request indicated by clicking the Directions button 606 of FIG. 6. A static map 800 of the geographic area surrounding the vendor's location is displayed along with static textual directions 802 to the vendor's location from nearby  
10 well-known landmarks or intersections. In an alternate embodiment of the present invention, a dynamic map 800 (graphical directions) is generated by methods of the present invention from the user's location (entered at program registration when first run on the user's computer system) to the vendor's location (provided in the advertising database along with other information about the vendor). Geographic mapping  
15 information for towns, cities, states, the Nation, as well as much of the world is readily available from a variety of commercial and governmental sources. Methods to compute a path from one location to another are well known in both the art of map generation as well as more generally in the mathematical study of graph theory. Any of such methods may be employed in the present invention. In addition to the dynamic map  
20 800 generation, dynamic textual directions 802 corresponding to the map are generated and displayed in the screen of FIG. 8. The Close button 804 is used to exit the directions display and return the user display to the previous vendor detail display. The Print button 806 serves to print the displayed map and directions on the user's  
25 printer.

#### ADVERTISING DATA STRUCTURES:

FIG. 9 depicts an exemplary structure of the advertising information as stored on CDROM (distributed to each user) or as stored on the disks or CDROMs of a central database server accessed through computer communication links (such as a Web  
30 server on the Internet). Advertising information for each of a plurality of vendors may

be accessed (located) by any of several indices. Vendors V1-V10 (918-936, respectively) may each be located by a link in the global master index 900. The global master index 900 includes the name, address, and phone number for each vendor V1-V10 (918-936) and an associated link to each vendor V1-V10 (918-936). The global master index 900 therefore permits a user to locate any vendor, regardless of geographic area, by name, address, or phone number.

In addition, the vendors may be accessed by their geographic area. Each geographic area, AREA1 902 and AREA2 908, includes a master index with an entry containing name, address, and phone number for each vendor in the area and a link to the corresponding vendor advertising files. Specifically, as shown in FIG. 9, the master index 904 of AREA1 902 has links to each of vendors V1-V5 (918-926, respectively) while the master index 910 of AREA2 908 has a link to each of vendors V6-V10 (928-936, respectively). The master index of each area permits the user to locate any vendor in the corresponding area by name, address, or phone number.

Each area also includes a category index with links to entries containing information about an area of commerce (a category). The category index 906 of AREA1 902 includes links to categories 914 (C1, C2, C3, etc.) while the category index 912 of AREA2 908 includes links to categories 916 (C1, C2, C3, etc.). In turn, each category contains links to vendors who choose to advertise in that category of commerce. For example, category C1 in categories table 914 of AREA1 902 has a link to vendor V1 918. Category C3 has links to vendors V3 922 and V4 924. Vendor V5 926 advertises in category C3 as well as others. The category index in each area permits a user to locate all vendors who provide goods or services in a particular category of commerce.

One of ordinary skill in the art will recognize many equivalent data structures within the scope of the present invention which may be utilized to represent the advertising information and the associated linking and relationship information. For example, the data structures may be represented by an HTML structured document as well as by traditional indexed file structures (i.e. database methods and structure).



**ADVERTISING KEYING:**

Vendors utilize information regarding efficacy of their advertising. Methods of the present invention discussed below provide keying information to vendors gathered from a user's pattern of use of the advertising products and services provided by the present invention. In particular, a keying file is created and maintained by the methods of the present invention to record a user's interaction with the advertising methods of the present invention. Each time an advertisement is displayed on the user's display (as discussed below), an entry is updated in the keying file to so indicate that the advertisement was presented to the user. Each time a particular advertisement is selected for detailed presentation (as discussed below), an entry in the keying file is updated to reflect the user's selection of a particular advertisement. The information in the keying file is transmitted to the central server site of the advertising service provider when the methods of the present invention are applied to connect to the service provider's central server. The information gathered in each user's keying file and collected at the provider's central server node may be reported to the vendors to provide the advertising efficacy information required by the vendors.

**ADVERTISING SEARCH AND DISPLAY METHODS:**

Methods of the present invention permit the user of a computing system to search, select, and review a desired vendor's advertisement or a group of related advertisements. The methods of the present invention include a plurality of search techniques and indices to permit significant flexibility to the user in selecting and receiving the vendor's multimedia advertising information presentation. The flowchart of FIG. 10 describes the operation of the methods of the present invention at the direction of the user's input and in conjunction with the vendors' multimedia advertising information presentations. A more detailed list of the specific menu functions and their hierarchical relationship to one another is presented below in tabular form.

Elements 1000-1004 of FIG. 10 initialize operation of the methods of the present invention by requesting that the user enter registration information on the first invocation of the method. The user's registration information is entered at the computer

system keyboard (or other user input devices) and is then stored on non-volatile storage of the user's computer system (e.g. a disk file) so that subsequent invocations of the method will skip this step. Element 1000 therefore tests whether the registration information is located on the disk of the computer system. If found, processing  
5 continues by skipping to element 1006. Otherwise, processing continues with element 1002 receiving the user's input information, and element 1006 storing the entered information in a disk file. Among other data, the registration information includes the user's address (geographic location). The user's address is used in several of the search options noted below, such as to determine the nearest advertising vendor or to  
10 generate a map and/or textual directions to a selected vendors location from the user's location.

Element 1006 is next operable to present the title page advertisement to the user through the multimedia presentation devices of the computer system. The title page advertisement may be selected by a vendor to afford improved visibility of the  
15 advertisement. Since the title page advertisement is always presented to the user, a vendor may perceive added marketing value in placing their advertisement in this portion of the advertising method. Typically, the title page advertisement will be presented to the user for a fixed period of time sufficient to convey the desired message to the user. The user may terminate the display of the title page advertisement by  
20 striking any key on the keyboard or by clicking the pointer device anywhere on the title page advertisement. An additional title page advertisement, possibly limited to text and graphics, may be constantly displayed in a reserved section of the user's computer system display. For example, such a constant advertisement may display scrolling or stationary text and/or animated or static graphical images. This advertising  
25 presentation may be preferred by vendors to maintain their advertising information at the forefront of the user's attention.

Following presentation of the title page advertisement, element 1008 is then operable to await a selection by the user before further processing continues. The user selects the next desired action by entering information through a keyboard or clicking  
30 a mouse or other graphic input device. The functions available include: selection of

one of several available geographic area subsets of the advertising information available on the user's computer system (i.e. the specific local groupings on the distributed CDROM), selection of the online directory services to connect to the central advertising database, or selection of any of several "toolbar" options (noted below in  
5 tabular form) to allow the user to more rapidly control the details of the presentation of the advertising information.

When a function selection is made by the user and sensed by operation of element 1008, elements 1010-1020 then perform processing steps appropriate to the selected function. Elements 1010-1014 serve to switch processing to the element  
10 appropriate for the selected function, namely elements 1016-1020, respectively. Specifically, when element 1010 determines that a particular geographic area has been selected by the user, element 1016 is next operable to permit further interaction with the user to present selected advertisements in the selected geographic area. One of ordinary skill in the art will readily recognize that elements 1010 and 1020 are  
15 representative of the processing to select one of one or more available geographic areas stored on the database presently in use (i.e. the user's CDROM or the central database). A particular user's CDROM may contain a single geographic area or even a portion of a larger area (such as may be the case in a large metropolitan area). Alternatively, a particular user's CDROM may contain a plurality of geographic areas  
20 (such as may be the case in rural or less densely populated areas). The central database contains all advertising of all participating vendors in all geographic areas supported by the service provider. Processing as depicted in FIG. 10 then continues by looping back to element 1008 to await another selection by the user.

FIG. 11 is a flowchart depicting additional detail of operation of the methods of  
25 the present invention which permit the user to select a particular advertisement or group of advertisements for presentation of the vendor's information. The flowchart of FIG. 11 is representative of the processing of both elements 1016 and 1018 of FIG. 10 in that both permit the user any of several options to narrow the search for relevant vendor advertising information. Element 1016 differs from element 1018 primarily in  
30 that element 1016 processes user selections relative to the advertising information in

a particular geographic area while element 1018 permits essentially the same user selection processing but over the entire online central database of advertising accessible over computer communication networks.

5 Element 1100 is first operable to await a selection by the user as to a desired mode of searching or limiting the numerous advertisements stored in the selected storage medium (i.e. CDROM or central database via a network connection). Following the user's selection, elements 1102, 1110, 1116, and 1122 are operable to determine which type of search mode the user selected in element 1100 and to switch processing to the appropriate next element.

10 If the user selected a search by category of commerce, then elements 1102-1108 are operable to determine which predefined category of commerce the user desires. Element 1104 presents the user with a menu of predefined categories from which to select. Element 1106 is then operable to await the user's selection of a desired area to limit the number of advertisements to search. Responsive to the user's selection input, element 1108 is next operable to present the user with the first page of advertisements in the selected category. Subsequent pages of advertisements may be selected by the user selecting the page forward and page backward functions discussed below.

15 Element 1127 is then operable to update the keying file (discussed above) to reflect the presentation of all advertisements on presently on the display. Processing then continues with element 1128 to await user selection of a particular advertisement.

20 In like manner, if the user selected a search by vendor name, address, or phone number, then elements 1110-1114, 1116-1120, and 1122-1126, respectively, are operable to determine which vendor the user seeks. Element 1112, 1118, or 1124 prompts the user to enter the desired name, address, or phone number, respectively according to the type of search selected by the user and determined by elements 1110, 1116, and 1122. Following entry of the desired search data, elements 1114, 1120, or 1126 displays the first page of vendor advertisements which match the desired search data entered by the user responsive to the prompt of elements 1112, 1118, and 1124, respectively. Processing then continues with elements 1127 to update the keying file

25  
30

and element 1128 to await user selection of a particular advertisement (as above).

Positioning of an advertisement on the first page of a category may be preferred by vendors to improve exposure or visibility of their business to the users. This preferred position may be provided with assurance to vendors who choose to pay for such assurances. Such an advertisement is referred to herein as a preferred position advertisement or as an advertisement with a preferred position attribute associated therewith as compared to an advertisement with a normal position attribute associated therewith. A second type of preferred positioning is available to vendors by selecting presentation of their advertising information in a rotating format with other preferred advertisements. Vendors selecting rotating preferred ordering are presented next after the first page preferred position advertisements. To assure approximate equality of exposure to the rotating advertisements, all rotating preferred position advertisements are shifted or rotated in their positioning on the first and subsequent pages. In other words, each time a category is accessed, the positions of the rotating preferred position advertisements are shifted so that a different set of vendors' advertisements appears first (following the preferred position advertisements) when the user selects the category. The positions of the rotating preferred position advertisements may be shifted or rotated in a repeated sequence or may be randomly altered to help assure equal distribution of the vendor presentations. This shifting or rotating of rotating preferred position advertisements helps assure rough equality of exposure to the various vendors in a particular category.

All other vendors' advertisement (non-preferred position advertisements) will appear in standard alphanumeric order after the preferred position and rotating preferred position advertisements.

An alternate embodiment of the present invention simply lists all vendors without preferred position ads rather than defining another type of ad for rotating display. Only the preferred position ads are presented (graphically) to the user in such a case and all other vendors are simply listed in alphabetical order (e.g., in a scrolling textual section of the display screen - not shown). Vendors in the listing who have a standard ad (not a preferred position ad) are highlighted to draw attention of the user to these

vendors. The user may then click the highlighted listed of a selected vendor to view the ad presentation.

Elements 1128 and 1130 are then repetitively operable to await selection of a particular one of the displayed vendor advertisements. The advertisements may be presented in a mixture of text and/or graphics as though on the pages of a telephone directory with its pages open to a desired category, or to groups of similar names, addresses, or phone numbers. The text and graphics displayed on the user's computer system provide a brief summary of the associated vendor's advertised information. Alternatively, at the user's option, the advertisements may be displayed in an alphanumerically indexed mode showing only textual keys related to the corresponding vendors (e.g. name, address, phone, etc.). A user may utilize the toolbar functions discussed below to change the display to other pages of advertisements or to return to earlier selection functions discussed above. Toolbar functions (noted below) are used to switch the display between the pure textual index of vendors and the text and/or graphics display mode. Specifically, the A-Z index button, discussed below, switches the display to the textual display of vendors in alphanumeric order while the advertisements button, discussed below, switches the display back to the text and/or graphics mode. Element 1128 awaits the user's selection of a particular advertisement displayed in either mode on the presently displayed pages. The user selects a desired advertisement by clicking a pointer on the desired advertisement. In response to the user's selection of a particular advertisement, element 1130 is next operable to present the multimedia presentation and associated details of the vendor's advertising information. As noted above, the multimedia advertising information may present any combination of text, graphics, video, and audio information depending upon the desire of the advertised vendor and depending upon the capabilities of the user's computer system. Following presentation of the selected vendor's advertising information, processing then continues by looping back to element 1128 to await the user's selection of another vendor's advertising information displayed on the open pages on the user's computer system display.

Any time the user's computer display is altered by the methods of the present

invention to present different advertisements, the methods of the present invention will resume operation at element 1127 of FIG. 11 to update the keying file to reflect the newly displayed advertisements. Specifically, several toolbar functions, discussed below, cause the screen display to be re-drawn with new advertisements which in turn causes the methods of the present invention to continue operation at element 1127 updating the keying file.

#### PRESENTATION OF A SELECTED ADVERTISEMENT:

FIG. 12 is a flowchart depicting additional detail of the processing associated with element 1130 of FIG. 1 presenting a selected vendor's advertisement to a user. Element 1200 is representative of all the processing required to present the selected vendor's advertising information to the user. As noted above, the information is a multimedia collection of parts including one or more of the following types of information: text, graphics, video, and audio. Apparatus and methods appropriate for presenting multimedia information are well known to those of ordinary skill in the art. The information is stored in one or more files on the CDROM or central database and is associated through the indexing structures of the database with the selected vendor.

Element 1201 is next operable to further key the presented advertisement. A keying file, as discussed above, is maintained by the methods of the present invention to record each selection by the computer system user of a displayed advertisement. Keying information is provided to participating vendors by the provider of the products and services of the present invention to permit the vendors to improve the content and to better target their advertising presentations to the marketplace. This keying file records the number of "hits" and presentations of each advertisement over a period of time. The entire keying file is transferred to the provider of the advertising products and services when the user connects to the central database server. The advertising service provider may then accumulate the keying information from each user's computer system to provide each vendor with periodic reports on the effectiveness of their advertising information presentations.

Element 1202 then awaits further direction from the user to select which, if any,

additional details the user wishes to view with respect to the selected vendor. Responsive to the user's selection, elements 1204, 1214, 1226, and 1234 are then operable to switch processing to the appropriate next element to process the user's selection. Specifically, element 1204 switches processing to elements 1206-1212 responsive to a user request to view special offer coupons of the selected vendor, element 1214 switches processing to elements 1216-1224 responsive to a user request to view directions to the vendor's location, element 1226 switches processing to elements 1228-1232 responsive to a user request to connect to the vendor's computer system, element 1236 switches processing to elements 1238-1240 in response to a user's request to dial the vendor's voice telephone number, element 1242 switches processing to elements 1244-1246 in response to a user's request to E-mail a message to the vendor's E-mail address, and element 1234 completes processing for the presently selected advertisement.

Elements 1204-1212 perform the processing required to present the user with the vendor's special offer coupons (if any). A vendor may choose to include coupons to offer special promotions to users of the present invention. Element 1206 displays the text and graphics associated with the coupon (if any) on the users computer system display. Element 1207 then awaits the user's selection of a particular one of the displayed vendor coupons. Elements 1208-1212 are then operable to determine whether the user wishes to print the displayed coupon. If the user does not wish to print the coupon, then element 1208 continues processing by looping back to element 1202 to permit other detailed information to be obtained by the user. If the user requests printing of the coupon then element 1210 determines whether the coupon may be printed again. If the coupon has not been printed too many times, then processing continues with element 1212 to print the vendor's special offer coupon. In either case, processing continues by looping back to element 1202 to permit other detailed information to be obtained by the user.

Each time a coupon is printed by element 1212 a log of the coupon being printed is recorded on the permanent storage (i.e. in a disk file) of the user's computer system. If the vendor wishes to limit the number of times a coupon is printed, the methods of the



present invention will determine by operation of element 1210 whether the coupon has already been printed the permitted number of times. This log information is maintained by methods well known to those of ordinary skill in the art in a manner which hides the recorded log so as to make it more difficult for a user to circumvent the vendor's desire to limit use of the coupon.

5 Elements 1214-1224 perform the processing required to present the user with directions to the vendor's location. The information stored in the CDROM or central database includes geographic positioning information of each vendors' location. At time of registration of the present invention, at first use of the invention, the user supplies geographic location information for their home site. This geographic information is combined with map information pertaining to the geographic area selected for search to generate a graphic map and associated textual directions from the user's location to the selected vendor's location. Element 1216 generates the requisite map and directions and element 1218 displays the generated map and directions on the user's computer system display. Elements 1220-1222 are then operable to determine whether the user wishes to print the displayed map and directions. If the user does not wish to print the information, then element 1220 continues processing by looping back to element 1202 to permit other detailed information to be obtained by the user. If the user requests printing of the map and directions then element 1222 prints the displayed map and directions. As noted above, an alternative embodiment of the present invention displays and prints statically defined maps and associated directions to simplify operation of the present invention and to reduce processing requirements on the user's computer for the generation of dynamic maps and directions. In either case, static or dynamic direction printed or not, processing continues by looping back to element 1202 to permit other detailed information to be obtained by the user.

20 Elements 1226-1232 perform the processing required to connect the user's computer to the selected vendor's computing system(s). Such a connection may be by direct dialing of a modem or may utilize standard computer networking capabilities. One of ordinary skill in the art will readily recognize that the connectivity may be used

for direct interaction with proprietary computing applications on the vendor's systems (i.e. order entry and marketing functions) or may utilize standard computer networking features (such as Internet E-mail, Web access, Telnet, or FTP). The methods and apparatus required for such connectivity are well known and readily available to those of ordinary skill in the computing arts. Element 1228 is first operable to make the requisite connection between the user's computer system and the vendor's computing system(s) via modem connections or other well known network connections. Element 1230 is next operable to await the user's completion of the use of the established connection after which element 1232 is operable to disconnect the connected computing systems. Processing continues by looping back to element 1202 to permit other detailed information to be obtained by the user.

Elements 1236-1240 perform the processing required to automatically dial the vendor's voice telephone number to permit oral communications between the user and the vendor. Element 1238 is operable to dial the user's telephone by use of autodial features of the user's computer system. A computer data/fax modem is often used for this autodial function (as are many other telephone devices). When the dialing is completed, element 1240 is next operable to prompt the user to pick up the dialed telephone to commence oral communications. Such computer automated dialing is well known to those of ordinary skill in the art and need not be discussed in further detail. Processing continues by looping back to element 1202 to permit other detailed information to be obtained by the user.

Elements 1242-1246 perform the processing required to compose and transmit E-mail to the vendor's E-mail address. Element 1244 is first operable to permit the user to compose a desired E-mail message. Any of several well known text editing techniques readily available to those of ordinary skill in the art may be used to permit the user to compose the desired E-mail message. Element 1246 is then operable to initiate the transmission of the E-mail message to the vendor's E-mail address. Well known computer communication and networking techniques may be used to transmit the E-mail message. Processing continues by looping back to element 1202 to permit other detailed information to be obtained by the user.

**TOOLBAR FUNCTIONS:**

The toolbar functions are activated by a user by clicking the labeled button on the display (or by other standard user interface techniques). The toolbar functions are displayed at all times during the execution of the methods of the present invention. Each toolbar function provides the user with a quick and convenient function to control the operation of the methods of the present invention. Each pointer function which is presently meaningful in view of the present state of interaction with the user may be activated by clicking the pointer on a corresponding button icon. Functions which are not presently meaningful in view of the state of interaction with the user perform no function and are simply ignored by the methods of the present invention.

Computer programming methods and structure to implement the toolbar functions are well known to those of ordinary skill in the design and implementation of user interfaces in, for example, Microsoft Windows. Such event driven user interfaces are common in the design of graphical user interfaces. FIG. 13 is a flowchart which suggests the detailed processing performed in response to a user's click of the pointer on one of the toolbar button icons. FIG. 13 graphically depicts the toolbar functions as a method which awaits a user toolbar function selection and then processes the selected toolbar function.

Elements 1300-1302 are operable to switch the processing of the methods of the present invention back to a point wherein the user's computer system display presents the open page of advertisements corresponding to the most recent search by category discussed above. The advertisements are displayed in the mode of text and/or graphics. Elements 1304-1310 are conversely operable to switch the advertisement display to a text only mode wherein the textual key fields of a vendor (e.g. the name address and phone number) are displayed on the open pages of the directory. Specifically, elements 1304-1306 are operable to switch the method back to a text only display of the last displayed category of vendor names in the presently selected geographic area while elements 1308-1310 are operable to switch the user's display to a master A-Z index of all vendors stored in the selected medium (CDROM or online central database). In all cases, processing then continues at label "H" at element 1128

of FIG. 11 to await the user's selection of another advertisement from the open page of advertisements.

5 Elements 1312-1314 are operable to switch the processing of the methods of the present invention back to a point wherein the user selected a business category from the predefined list of categories. Processing then continues at label "E" with element 1102 of FIG. 11 to await the user's selection of one of the predefined categories of business. In like manner, elements 1316-1318 permit the user to select a new geographic area by continuing processing at label "A" with element 1008 of FIG. 10.

10 Elements 1320-1324 are operable to locate the vendors in the presently selected area and category which are geographically nearest the user's location. If the user has not yet selected an area and category, this function will first prompt the user to select an area and category. Specifically, element 1322 determines the nearest vendors by determining the distance from each vendor's location to the user's location. The proximity of the vendors to the user's location is determined by any of several well  
15 known computational or graphical techniques (e.g. grid mapping). The nearest vendors so determined are displayed to the user so that if there are multiple vendors within a small area, the user may select the preferred vendor. The advertisement for the nearest vendor is then presented to the user by operation of element 1324. Processing then continues at label "B" with element 1202 of FIG. 12 to permit the user to select  
20 additional detail of the vendor's advertisement for presentation.

Elements 1326-1328 are operable to switch the user's display to a previous or subsequent page in the selected category of vendor advertisements. Processing then continues at label "H" with element 1128 to await the user's selection of a displayed advertisement. In like manner, elements 1330-1332 are operable to print whatever is  
25 presently displayed on the user's computer system display while elements 1346-1348 are operable to provide the user with context sensitive help information relevant to the present operation of the invention. Elements 1336-1338 operate to close the presently displayed screen (whether an advertisement, a category selection list, etc...) and switches the screen back to the display which preceded the present display. In all  
30 cases, processing continues at label "D" (on FIG. 13) by resuming the operation in

process before the print, close, or help operation was selected by the user.

Elements 1340-1342 are operable to close the currently selected geographic area. Processing then continues at label "A" with element 1008 of FIG. 10 to permit the user to select a new geographic area. Element 1334 switches the user's display to the  
5 online connection screen for accessing the central database of vendor advertisements. Processing then continues at label "F" with element 1012 to effectuate the connection to the central database and permit user selection of vendors therefrom.

Lastly, element 1344 is operable to terminate the operation of the methods of the present invention in response to the user's selection. One of ordinary skill in the art will  
10 readily recognize that the toolbar functions described above are only exemplary of a user interface that eases the user's interaction with the present invention. Many other equivalent and related functions and structures may be implemented by those of ordinary skill in the art to provide an easy to use interface between the advertising database and the user.

#### MENU STRUCTURE:

The methods and structure of the present invention may also be understood as a hierarchical set of menus comprised of selectable items and submenus. The menus may be implemented as a traditional graphical user interface application program  
20 written for operation on systems such as Microsoft Windows or Apple Macintosh, or, as noted above, may be implemented as a structured object as defined by the Hypertext Markup language (HTML). The HTML document is then viewed using a standard commercially available "browser" program such as Netscape or Mosaic. In the table below, each item is labeled with a numeric identifier which indicates its  
25 hierarchy in the menu structure. Items selectable at the same level are indicated by incrementing numerals at the same level of the hierarchy. An item which comprises a submenu of additional items has each submenu item identified by a number having the same higher level (major) number with an incrementing minor number. For example, items numbered 1, 2, 3, etc. are all accessible at the highest menu level, whereas items  
30 numbered 2.1, 2.2, 2.3, etc. are accessible as items in a submenu corresponding to

item 2 at the higher level menu.

5

Item	Brief Description
0 Title Advertisement	Advertisement always displayed (in this preferred position) at start of program until user acknowledges or until a fixed timeout.
1 Opening Page	Displays name of advertising service and product provider and any preferred position advertisement along with geographic areas available for display.
2 Setup	Special setup menu available at first program startup to register user
3 Ad Areas	Submenu of geographic areas (i.e. cities) to select including global database available with network access
3.1 Ad Area 1..N	Displays a "closed" directory and awaits user selection from submenu to select type of search desired
3.1.1 A-Z Buttons	Displays a "closed" directory with buttons for the user to select an alphabetic section of the directory (options continue as for selection of an advertisement as below analogous to 3.1.2.1.1 and 3.1.2.1.2 above))
3.1.2 Business Directory	Limits the user's search to only vendors in the business section of the directory and awaits user selection of a particular method of search
3.1.2.1 By Category	Further limits user search to a selected category of commerce and awaits user selection for particular area of commerce
3.1.2.1.1 Category 1..N	Displays an "open" directory with advertisements in the selected category and awaits user selection of a particular advertisement for additional detailed display

10

5

10

3.1.2.1.1.1 Ad Detail 1..N	Displays the detailed information corresponding to the selected vendor's ad and awaits selection of special features of the advertisement
3.1.2.1.1.1.1 Coupon	Displays the selected vendor's special offer coupons (if any)
3.1.2.1.1.1.2 Directions	Generates and displays a map and textual directions from the user's location to the vendors location
3.1.2.1.1.1.3 Auto-dial	Automatically dials the vendor's phone number using a modem attached to the computer for purposes of oral, telephonic communications
3.1.2.1.1.1.4 Net Connect	Connects the user's computer to the selected vendor's system via standard network connections
3.1.2.1.1.1.5 E-mail	Permits the user to compose and send an e-mail message to the selected vendor
3.1.2.1.2 Nearest	Selects the vendor in the selected category which is geographically nearest the user and displays the corresponding advertisement (options continue analogous to 3.1.2.1.1.1 above)
3.1.2.2 By Name	Further limits the user's search to vendors whose name contains the search characters entered by the user (options continue analogous to 3.1.2.1.1 and 3.1.2.1.2 above)
3.1.2.3 By Address	Further limits the user's search to vendors whose address contains the search characters entered by the user (options continue analogous to 3.1.2.1.1 and 3.1.2.1.2 above)
3.1.2.4 By Phone	Further limits the user's search to vendors whose phone number contains the search characters entered by the user (options continue analogous to 3.1.2.1.1 and 3.1.2.1.2 above)

3.1.3 Government Directory	Limits the user's search to only agencies in the government section of the directory and awaits user selection of a particular method of search
3.1.3.1 By Agency/Office	Further limits the user's search to agencies whose name contains the search characters entered by the user (options continue analogous to 3.1.2.1.1 and 3.1.2.1.2 above)
3.1.3.2 By Agent/Officer	Further limits the user's search to agencies who are represented by the person whose name contains the search characters entered by the user (options continue analogous to 3.1.2.1.1 and 3.1.2.1.2 above)
3.1.4 Community Directory	Limits the user's search to only agencies in the community section of the directory and awaits user selection of a particular method of search (options continue analogous to 3.1.2.1.1 and 3.1.2.1.2 above)
5 3.1.5 Online Directories	Displays the directory of information currently available at the provider's central database of advertisements including other geographic areas (see 4.13 described below)
3.1.6 Maps	Displays a map of the selected geographic area and awaits user interaction to print or display other details of the mapped area
3.1.7 Favorite Selections	Displays a list of the user's favorite selections from the advertising database to permit rapid selection of commonly used advertisements
3.1.8 Reference	Displays a menu of common reference material and awaits user selection from the menu (e.g. metric or financial conversion data, agencies for reporting bad business practice, etc.)



3.1.9 Emergency	Displays a menu of emergency numbers appropriate to the selected geographic area	
4 Toolbar Options	A number of options are available for user selection at all times on the display screen and are collectively referred to as toolbar options	
4.1 Ads	Switches the user's display of the open directory to the text and/or graphics mode of display	
4.2 A-Z Index	Switches the user's display of the open directory to the pure textual keys mode of display (e.g. name address and phone)	
5	4.3 Category Index	Switches the user's display back to the category selection menu of the most recently selected area (as above at 3.1.2.1)
4.4 A-Z Master Index	Switches the user's display to an A-Z indexed display of all advertisers in all areas on the current database	
4.5 Nearest	Selects the vendor in the selected category which is geographically nearest the user and displays the corresponding advertisement (options continue analogous to 3.1.2.1.1.1 above)	
4.6 Page Fwd/Bwd	Displays the next/previous page of advertisements of the open directory for a particular geographic area or category of commerce	
4.7 Close	Closes the currently displayed screen and returns to the previous screen (that which preceded selection of the currently displayed screen)	
10	4.8 Close Area	Closes the directory for the selected area and returns the user to the area selection screen (as in 3 above)

4.9 Ad Areas	Permits the user to view advertisements in another area without closing the currently display area directory (if any)	
4.10 Print	Print the current screen to the user's printer	
4.11 Exit	Exits the program from any displayed screen	
4.12 Help	Provides context sensitive help for any screen or any particular field of any screen	
5	4.13 Online Connect	Automatically connects the user's computer to a central database of advertisements including other geographic areas
4.13.1 Long Distance Directory	Displays a menu of other areas geographically remote from the user for which advertising is available on the central database (options continue analogous to 3 above)	
4.13.2 Wholesalers Directory	Displays a directory of wholesalers (options continue analogous to 3.1.2.1.1 above)	
4.13.3 Manufacturers Directory	Displays a directory of manufacturers (options continue analogous to 3.1.2.1.1 above)	
4.13.4 Mail-order Directory	Displays a directory of mail-order vendors (options continue analogous to 3.1.2.1.1 above)	
10	4.13.5 Classified/Personal Ads	Displays a directory of classified/personal advertisements (options continue analogous to 3.1.2.1 above)
4.13.5 Political Gallery	Displays political advertising for federal, state, and local election issues and candidates (options continue analogous to 3.1.2.1 above)	

4.13.6 Products Gallery	Displays product advertising (e.g. advertising a product rather than the vendor - options continue analogous to 3.1.2.1 above)
4.13.7 Catalog Gallery	Displays catalogs from businesses of all types (options continue analogous to 3.1.2.1 above)
4.13.8 Internet Directory	Displays a directory of Internet addresses for advertising vendors (options continue analogous to 3.1.2.1 above)

5           While the invention has been illustrated and described in detail in the drawings and foregoing description, such illustration and description is to be considered as exemplary and not restrictive in character, it being understood that only the preferred embodiment and minor variants thereof have been shown and described and that all changes and modifications that come within the spirit of the invention are desired to be  
10 protected.

### Claims

#### **What is claimed is:**

1. A method, operable on a computer system having a display, for presenting multimedia advertising information to users of said computer system, said method comprising the steps of:

searching said multimedia advertising information responsive to a user request;

5 and

presenting said multimedia advertising information to a user of said computer system.

2. The method of claim 1 further comprising the step of:

presenting a preferred portion of said multimedia advertising information at the start of performance of the method independent of user search requests.

3. The method of claim 1 wherein said multimedia advertising information includes an entry for each of a plurality of vendors and wherein the searching step further comprises the step of:

5 searching said multimedia advertising information based upon a predefined index value on each said entry.

4. The method of claim 3 wherein said predefined index value is a value associated with each said entry and is selected from the group consisting of; a vendor name value, vendor address value, vendor phone number value, vendor geographic location, and vendor category of commerce value.

5. The method of claim 4 wherein each said has associated therewith a type attribute value selected from the group consisting of: preferred position ad, standard position ad, and listing.

6. The method of claim 5 wherein the searching step further comprises the step of:

providing a selected category of commerce value; and  
locating a subset of said entries having a category of commerce value equal to said selected category of commerce value.

7. The method of claim 6 wherein the step of presenting includes the step of:  
displaying, on said display of said computer system, each said entry of said subset having said preferred position type attribute value associated therewith.
8. The method of claim 7 further wherein the step of presenting further includes the step of  
listing, on said display of said computer system, each said entry of said subset having type attribute values associated therewith other than said preferred position type attribute value.
- 5
9. The method of claim 7 wherein the step of presenting further includes the step of:  
shifting the position on said display of said computer system of each of said subset of entries having a standard position associated therewith, wherein said shifting is relative to a previous display position of said each of said subset of entries having a standard position attribute associated therewith.
- 5
10. The method of claim 4 further comprising the step of:  
providing a geographic location of a user on said computer system.
11. The method of claim 10 wherein the searching step further comprises the step of:  
locating a subset of said entries having a geographic location value near said geographic location of said user.
12. The method of claim 11 wherein the presenting step further comprises the step

of:

displaying said subset of said entries in order of geographic proximity to said geographic location of said user.

13. The method of claim 3 further comprising the steps of:

displaying additional information for a particular one of said plurality of vendors in response to a user selection of said one of said plurality of vendors.

14. The method of claim 13 wherein said additional information is information selected from the group consisting of: vendor coupons, map to vendor location, directions to vendor location, inter-computer connection to vendor systems, inter-computer connection to advertising provider systems, email interfacing, and auto-dial  
5 for voice communication with vendor.

15. The method of claim 14 wherein the step of displaying additional information includes the step of:

displaying a static map to a vendor location.

16. The method of claim 14 wherein the step of displaying additional information includes the step of:

displaying static directions to a vendor location.

17. The method of claim 14 wherein the step of displaying additional information includes the steps of:

providing a user location of a user on said computer system;

generating a map from said user location to a vendor location; and

5 displaying the generated map.

18. The method of claim 14 wherein the step of displaying additional information includes the steps of:

- 5 providing a user location of a user on said computer system;  
generating textual directions from said user location to a vendor location; and  
displaying the generated textual direction.

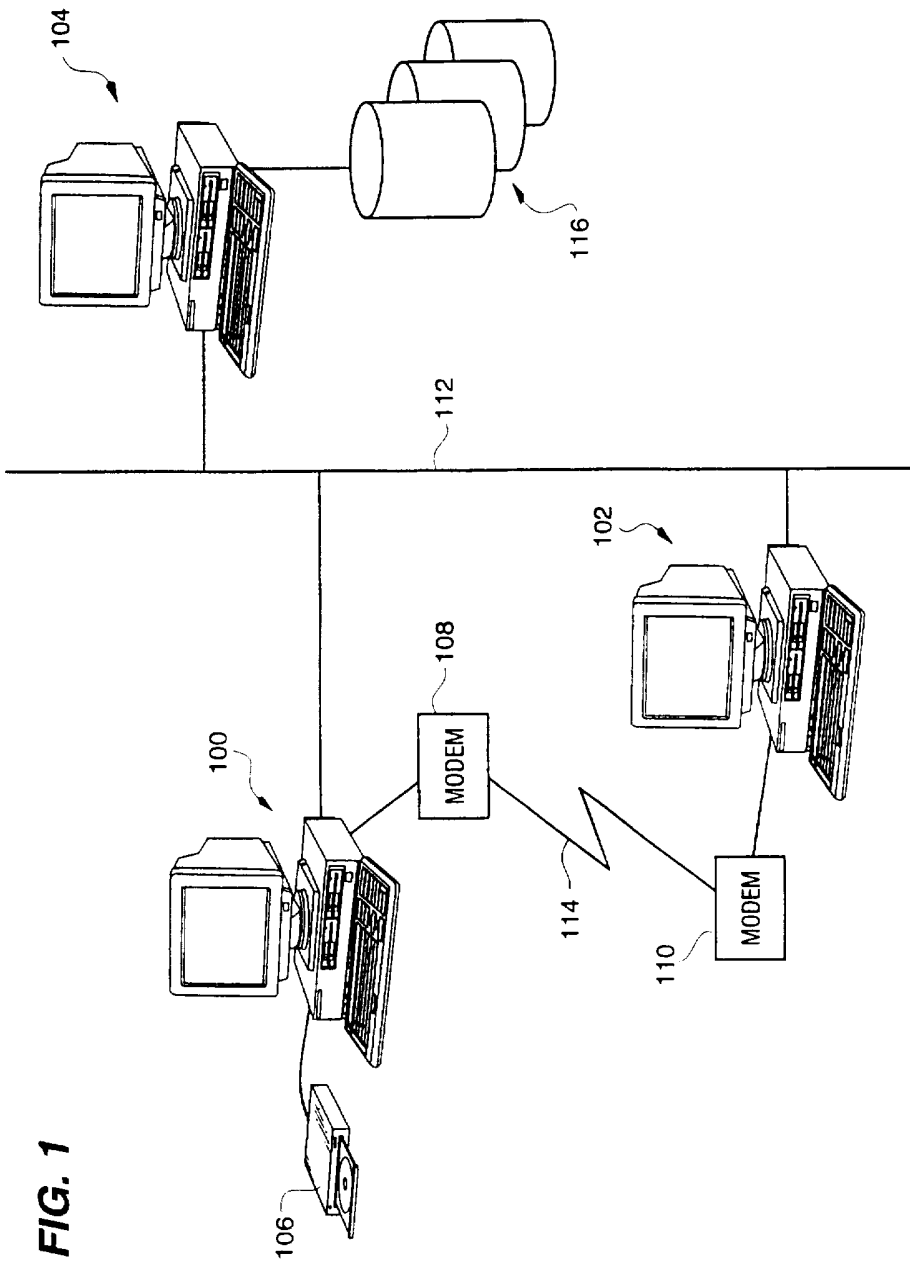
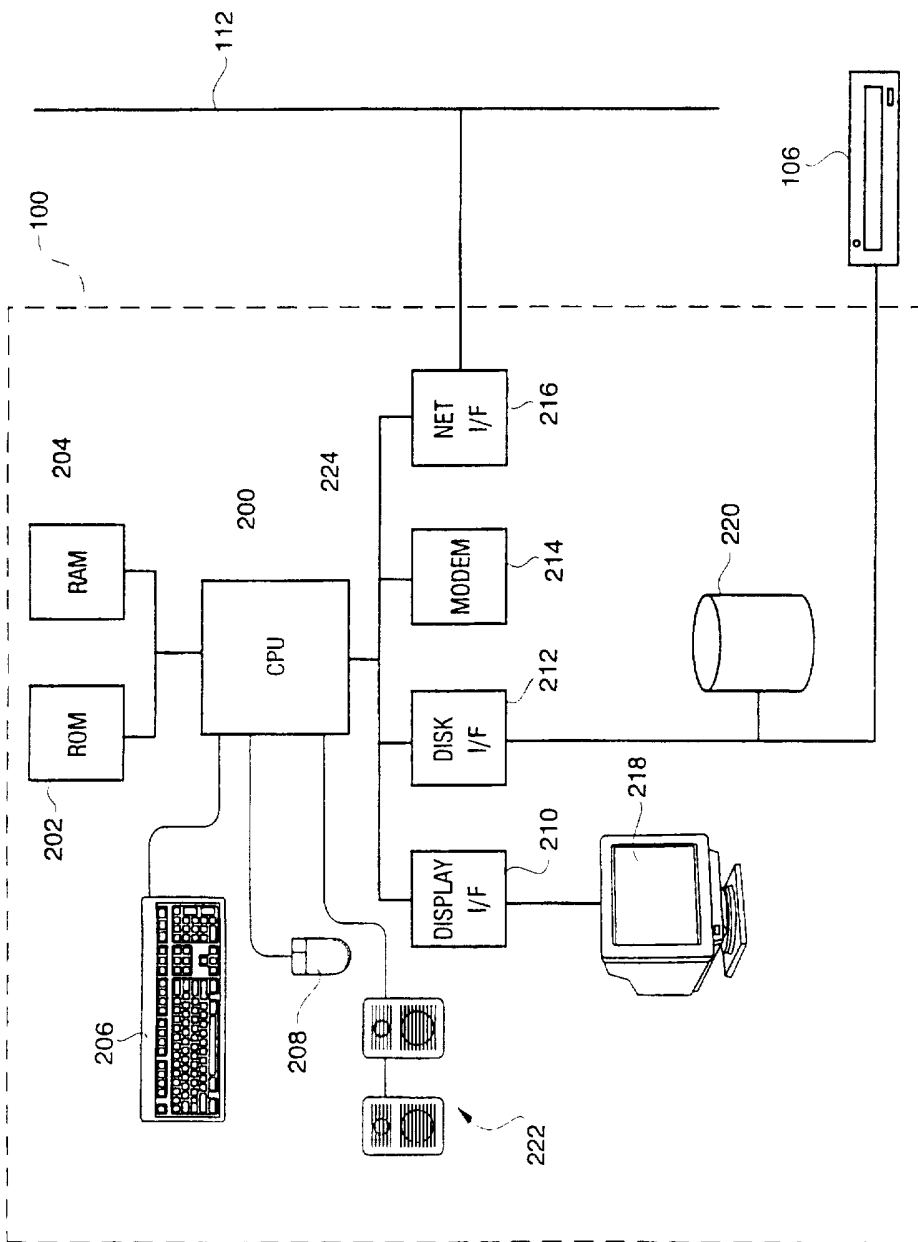

FIG. 1



FIG. 2



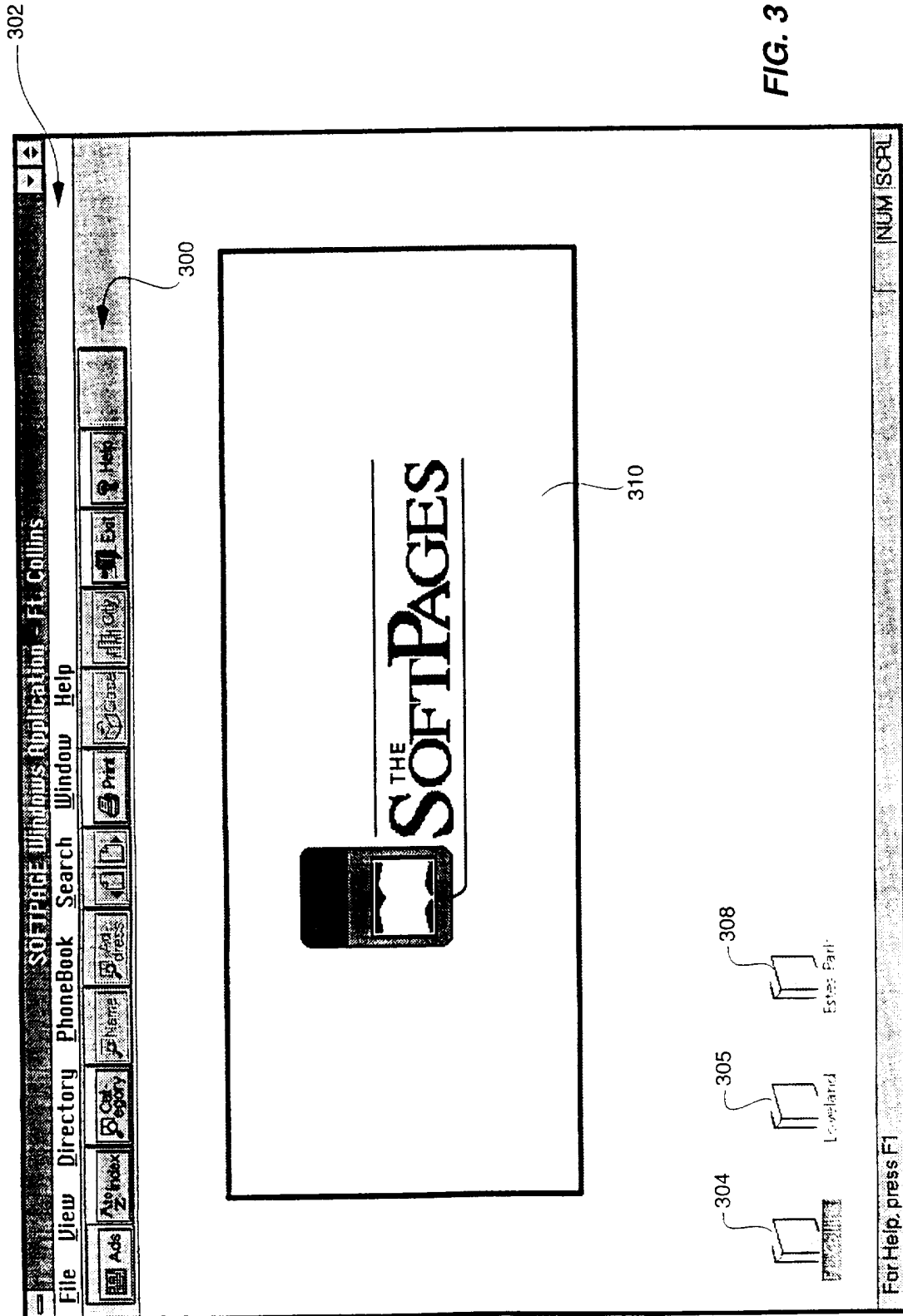

FIG. 3

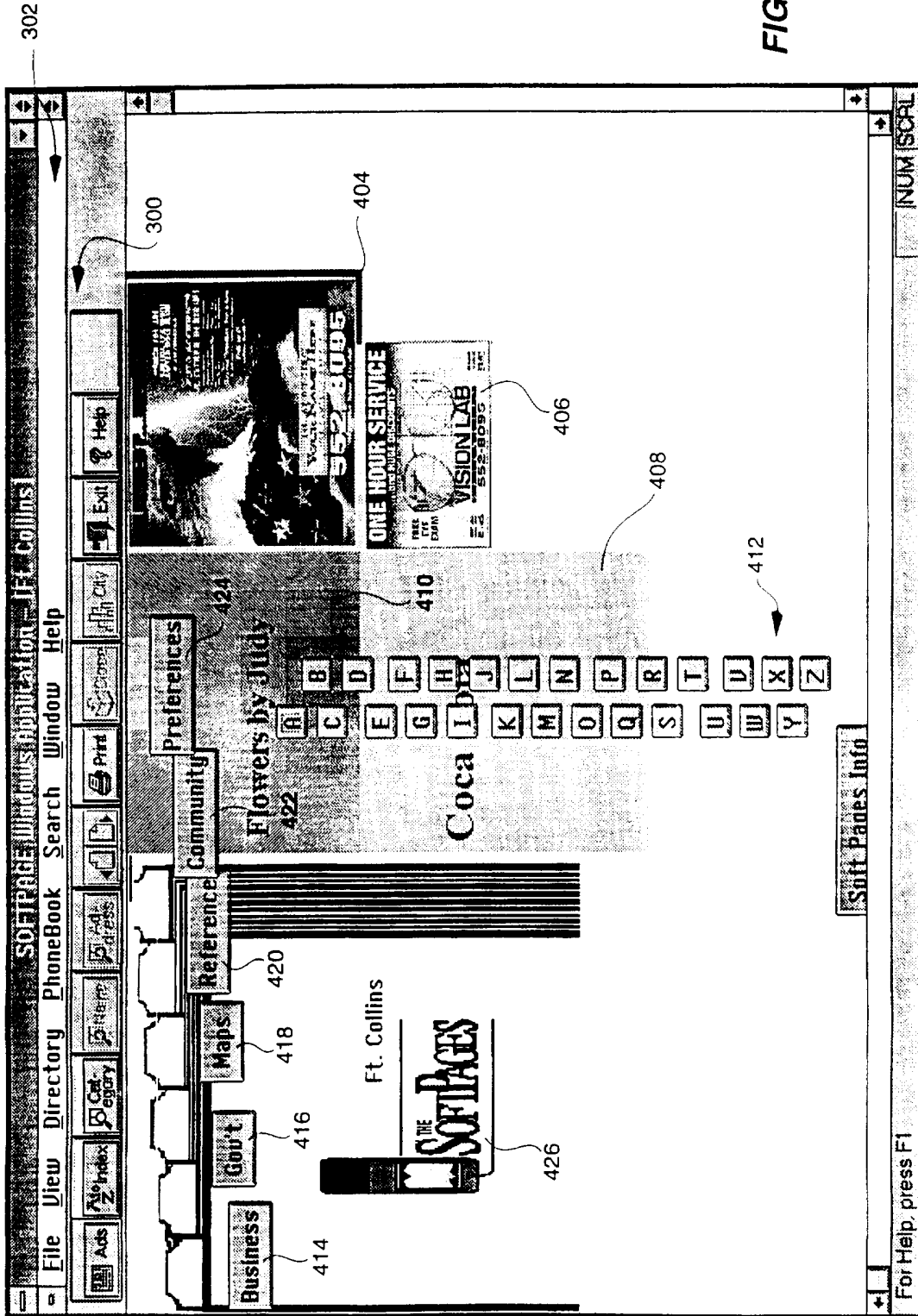

FIG. 4

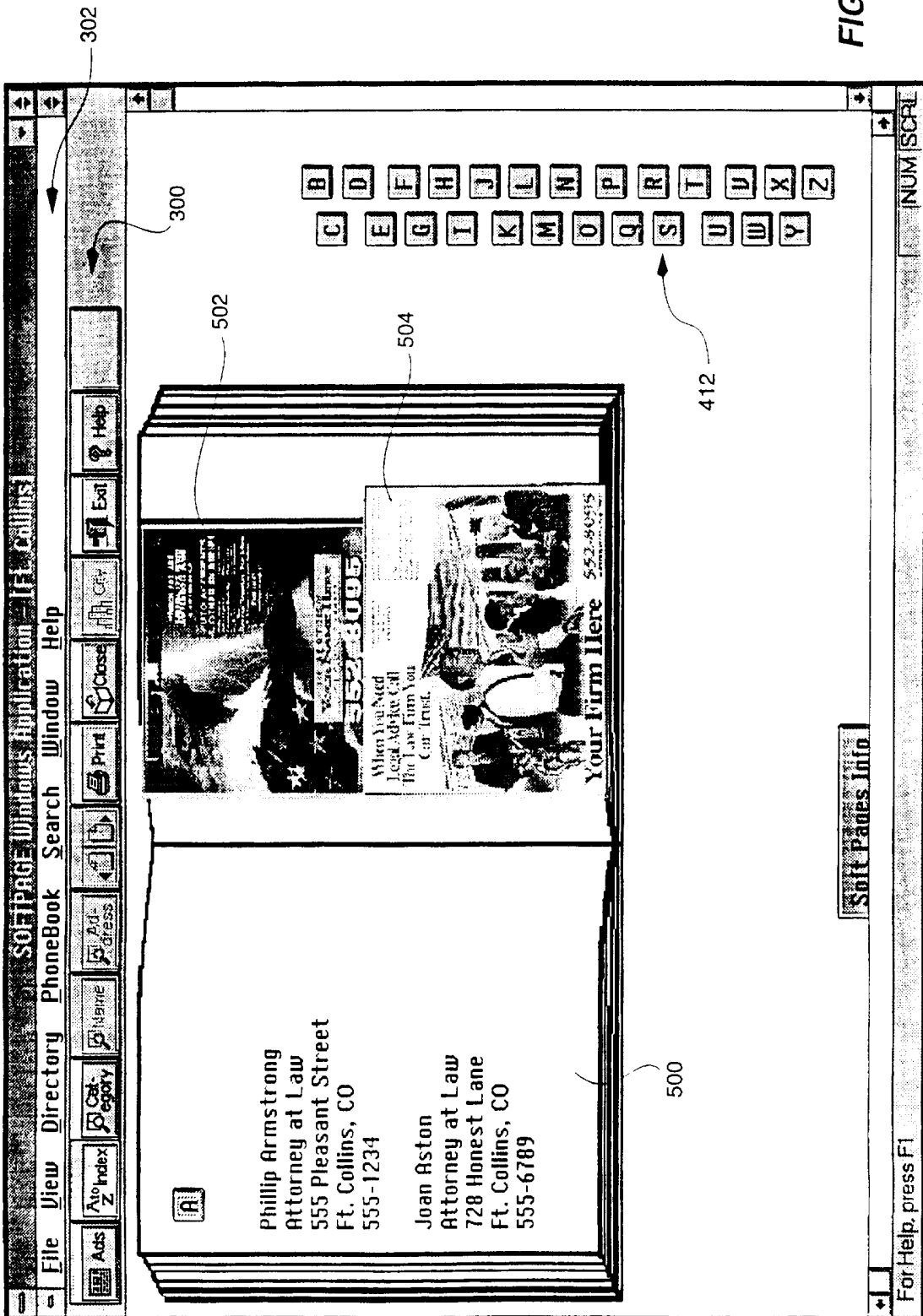

FIG. 5

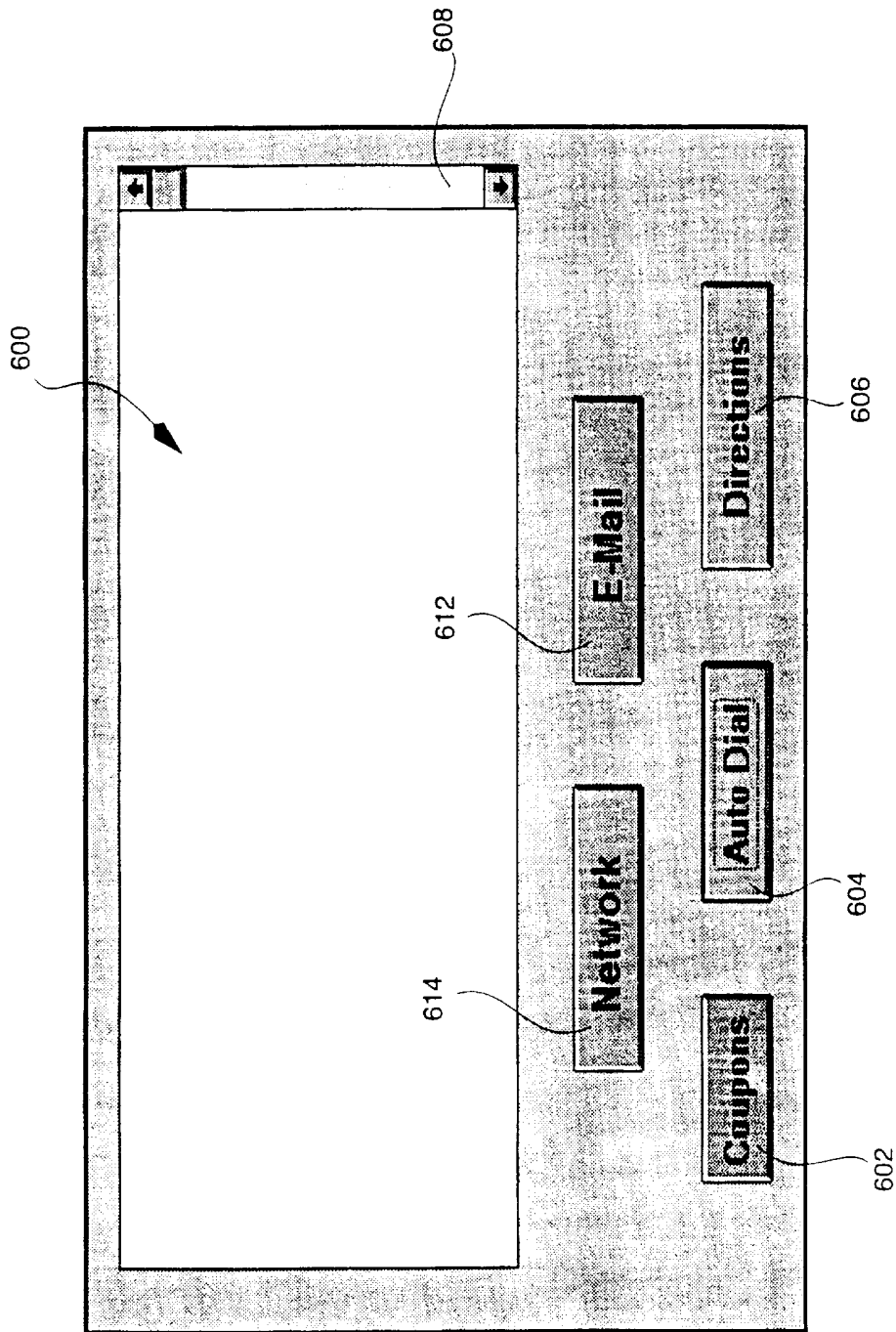

FIG. 6

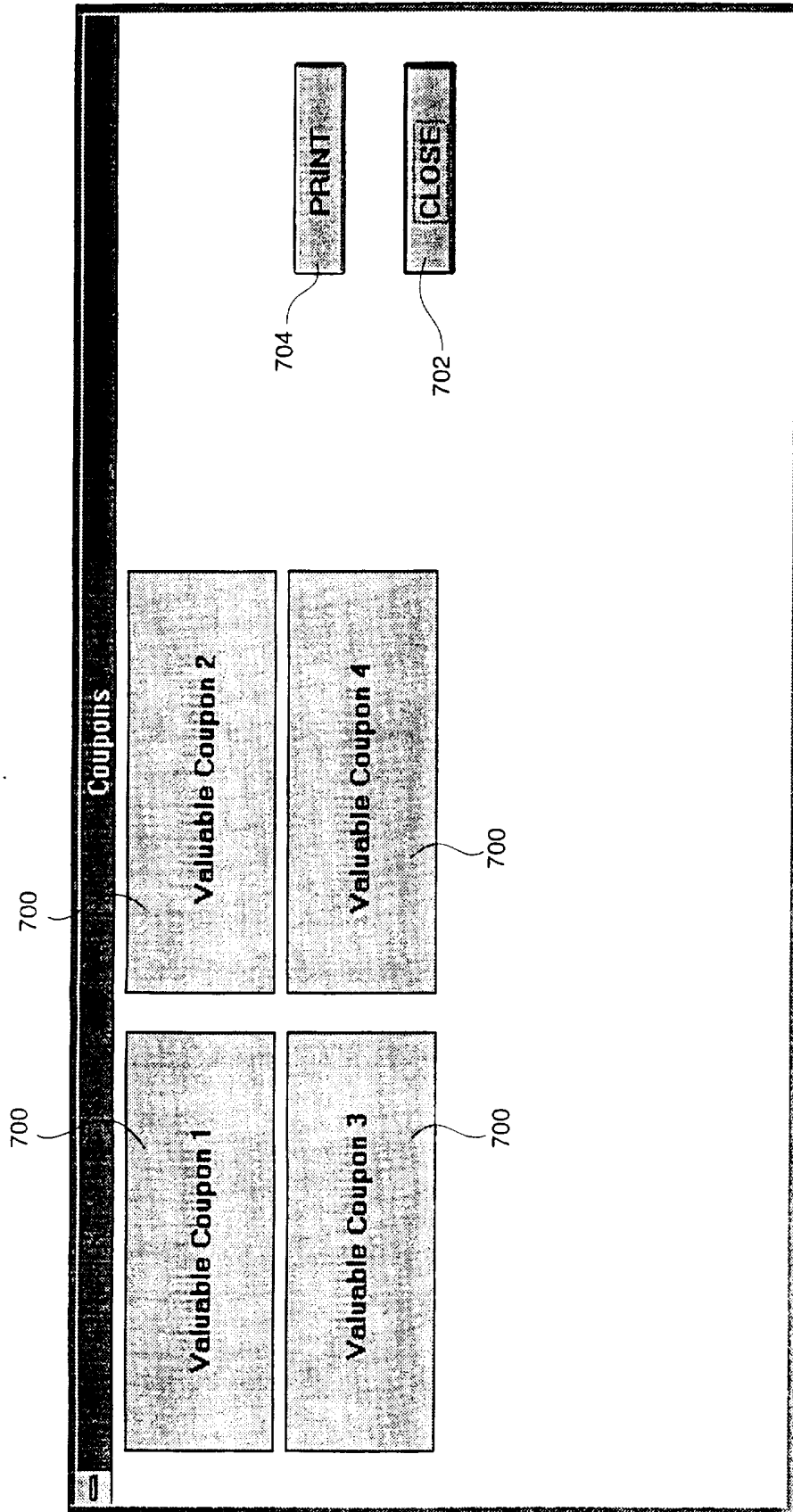

FIG. 7

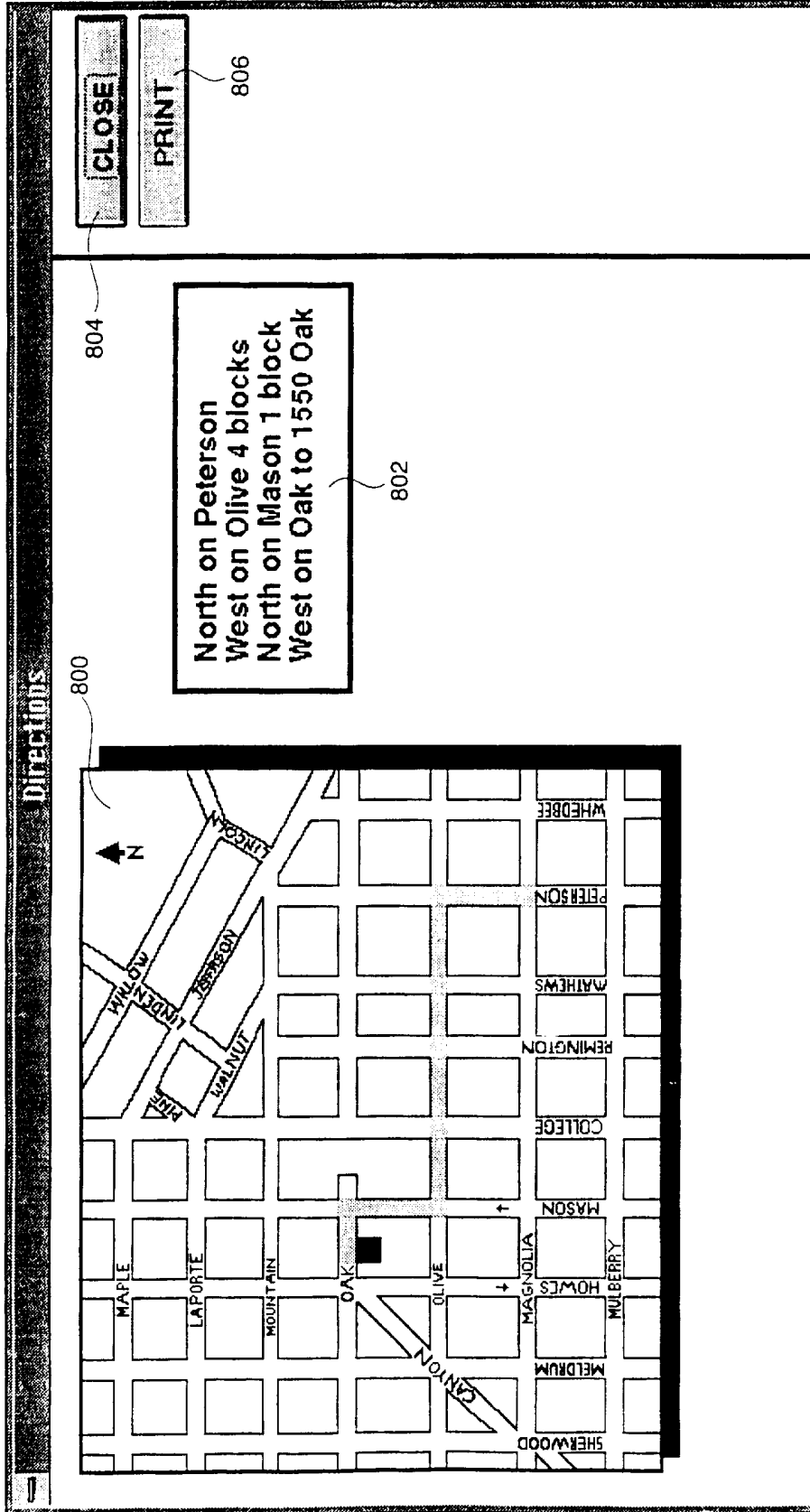

FIG. 8

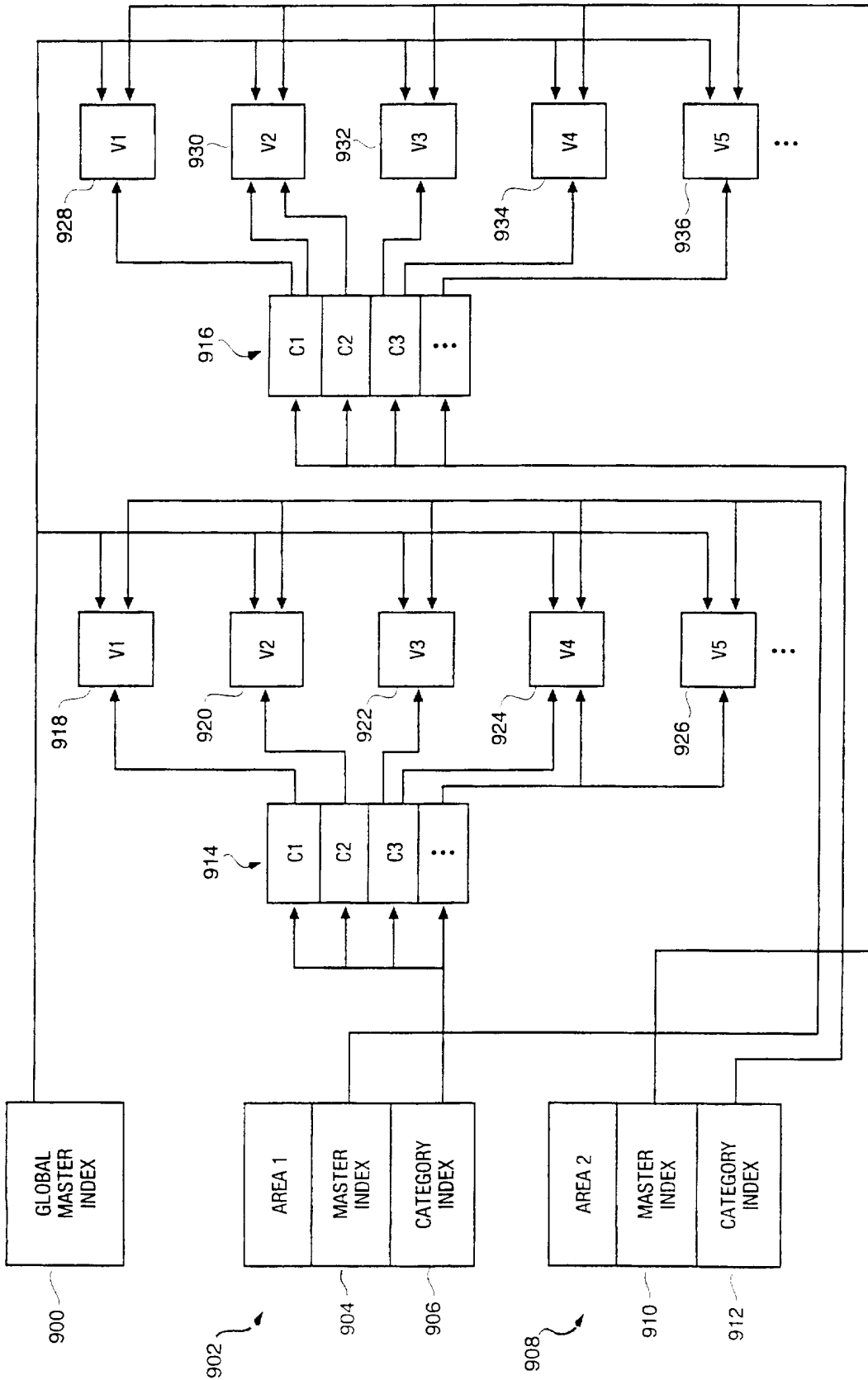
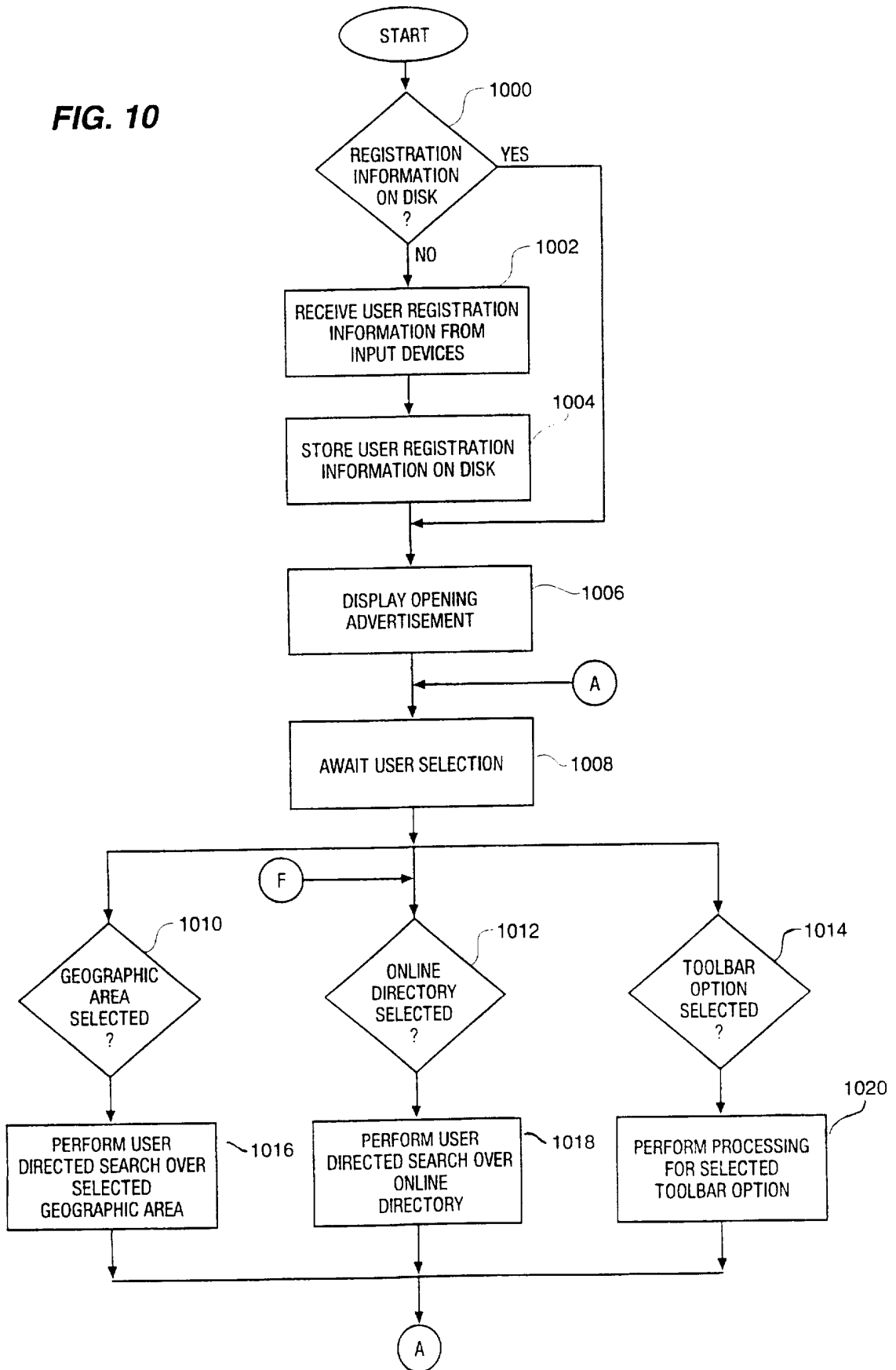
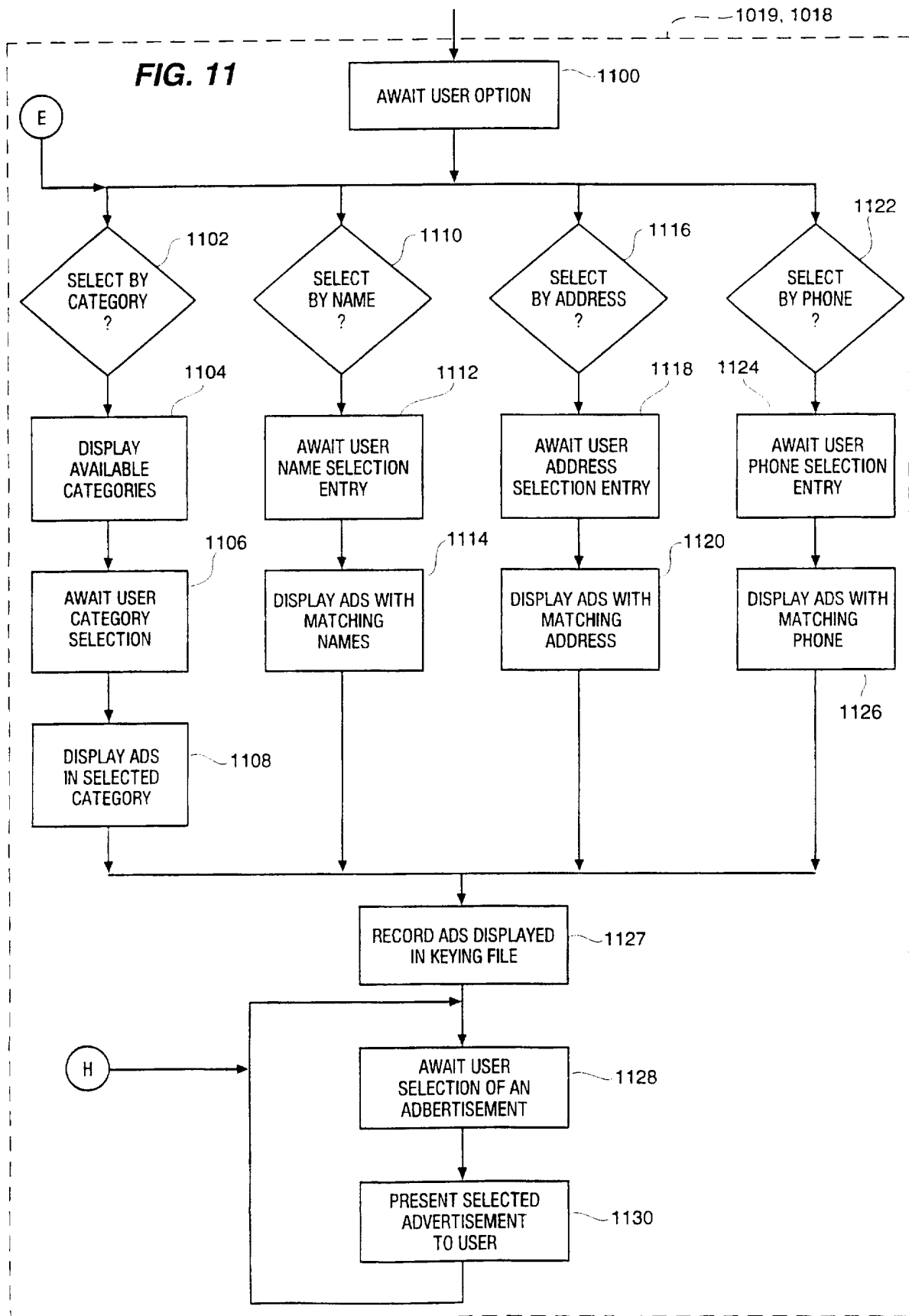

FIG. 9



FIG. 10





12/14

FIG. 12

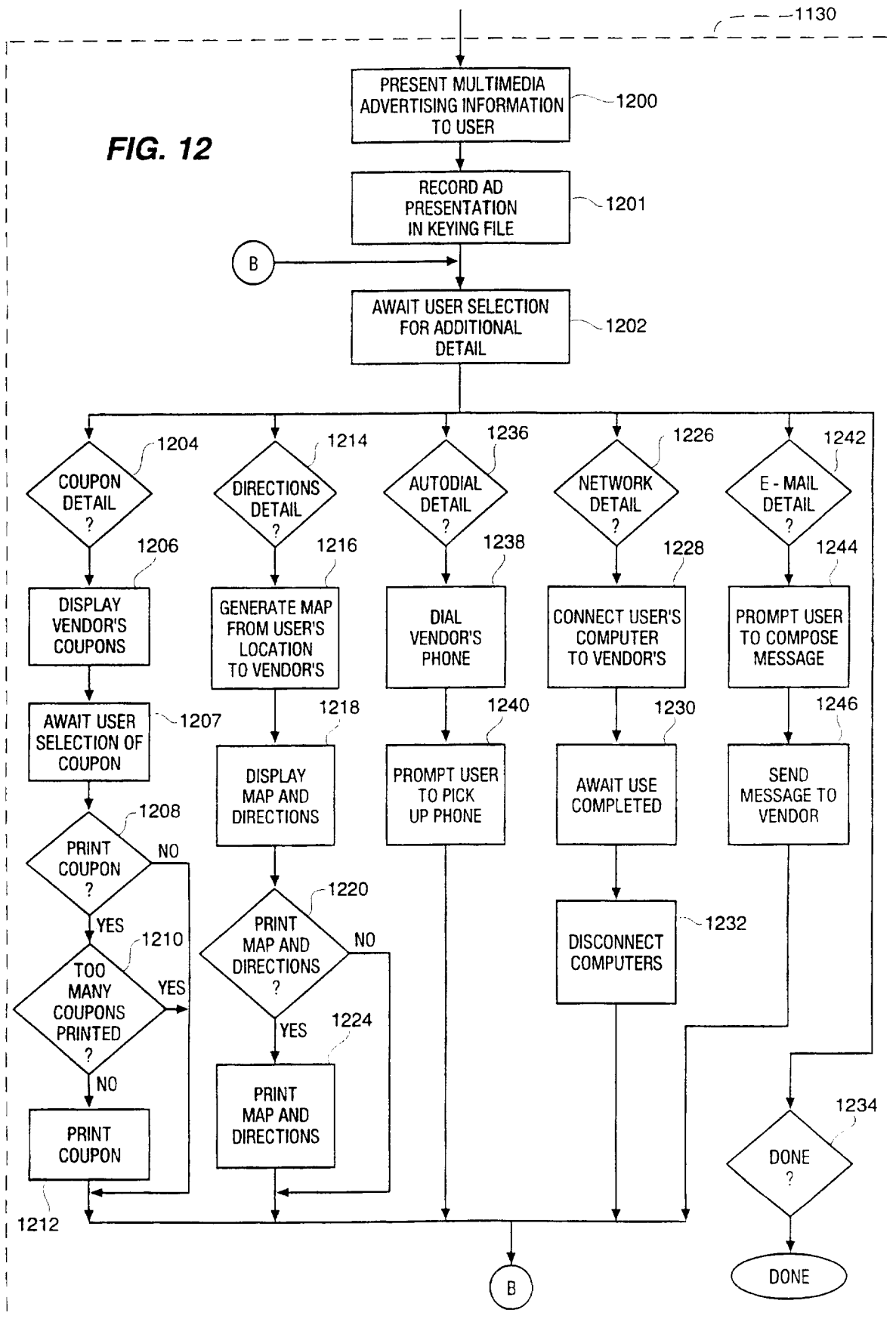

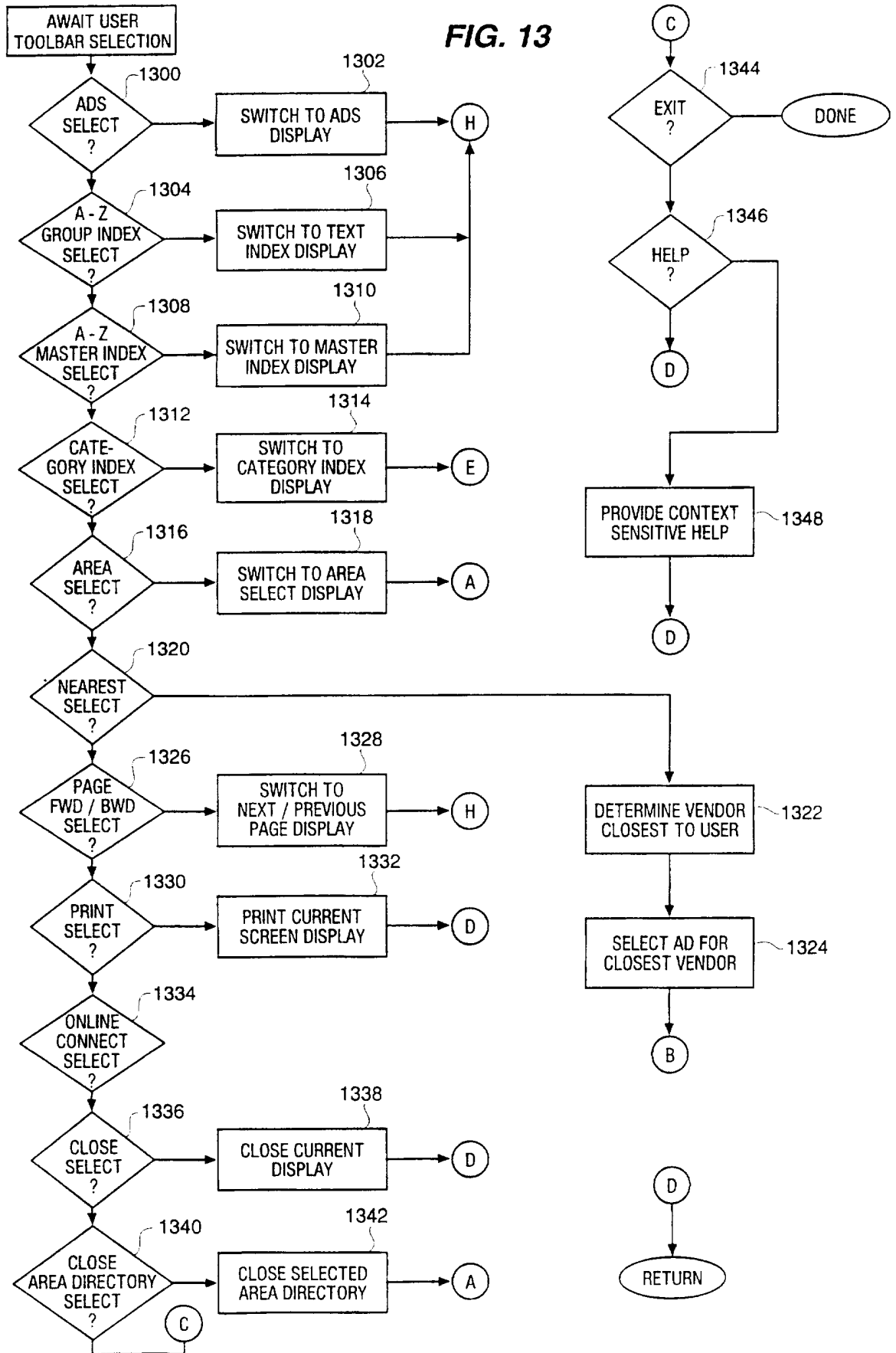

**When You Need  
Legal Advice, Call  
The Law Firm You  
Can Trust.**

**Your Firm Here**

**552-8095**

**OK**

THE FIRM HAS BEEN ADOPTED BY THE STATE BAR OF TEXAS AS A MODEL OF EXCELLENCE IN THE PRACTICE OF LAW. THE FIRM IS A MEMBER OF THE TEXAS BAR ASSOCIATION AND THE TEXAS BAR ASSOCIATION OF ATTORNEYS AT LAW. THE FIRM IS A MEMBER OF THE TEXAS BAR ASSOCIATION OF ATTORNEYS AT LAW AND THE TEXAS BAR ASSOCIATION OF ATTORNEYS AT LAW.

FIG. 14

INTERNATIONAL SEARCH REPORT

International application No.  
PCT/US96/20879

A. CLASSIFICATION OF SUBJECT MATTER

IPC(6) :G06F 17/21  
US CL :395/807, 762, 227

According to International Patent Classification (IPC) or to both national classification and IPC

B. FIELDS SEARCHED

Minimum documentation searched (classification system followed by classification symbols)

U.S. : 395/807, 762, 227, 201, 226, 601, 603, 615, 335, 774

Documentation searched other than minimum documentation to the extent that such documents are included in the fields searched

Electronic data base consulted during the international search (name of data base and, where practicable, search terms used)

C. DOCUMENTS CONSIDERED TO BE RELEVANT

Category*	Citation of document, with indication, where appropriate, of the relevant passages	Relevant to claim No.
A	US, A, 5,471,382 (TALLMAN ET AL) 28 November 1995	1-18
A	US, A, 5,319,544 (SCHMERER ET AL) 07 June 1994.	1-18
Y	US, A, 4,992,940 (DWORKIN) 12 February 1991, abstract, figures 2A-2b, col. 3-10.	1-18
Y,P	US, A, 5,500,514 (VEENEMAN ET AL) 19 March 1996, col. 3-16.	1-14
A	US, A, 5,283,639 (ESCH ET AL) 01 February 1994.	1-18

Further documents are listed in the continuation of Box C.  See patent family annex.

* Special categories of cited documents:	"T" later document published after the international filing date or priority date and not in conflict with the application but cited to understand the principle or theory underlying the invention
"A" document defining the general state of the art which is not considered to be part of particular relevance	"X" document of particular relevance; the claimed invention cannot be considered novel or cannot be considered to involve an inventive step when the document is taken alone
"E" earlier document published on or after the international filing date	"Y" document of particular relevance; the claimed invention cannot be considered to involve an inventive step when the document is combined with one or more other such documents, such combination being obvious to a person skilled in the art
"L" document which may throw doubts on priority claim(s) or which is cited to establish the publication date of another citation or other special reason (as specified)	"&" document member of the same patent family
"O" document referring to an oral disclosure, use, exhibition or other means	
"P" document published prior to the international filing date but later than the priority date claimed	

Date of the actual completion of the international search  
17 APRIL 1997

Date of mailing of the international search report  
**12 MAY 1997**

Name and mailing address of the ISA/US  
Commissioner of Patents and Trademarks  
Box PCT  
Washington, D.C. 20231

Authorized officer  
*B. Feld*  
JOSEPH H. FEILD  
Telephone No. (703) 305-3800

Facsimile No. (703) 305-3230