

(12) STANDARD PATENT
(19) AUSTRALIAN PATENT OFFICE

(11) Application No. **AU 2017353899 B2**

(54) Title
Curved expandable cage

(51) International Patent Classification(s)
A61B 17/56 (2006.01) **A61B 17/70** (2006.01)
A61B 17/58 (2006.01) **A61B 17/88** (2006.01)
A61B 17/68 (2006.01) **A61F 2/44** (2006.01)

(21) Application No: **2017353899** (22) Date of Filing: **2017.10.30**

(87) WIPO No: **WO18/085189**

(30) Priority Data

| (31) Number | (32) Date | (33) Country |
|-------------------|-------------------|--------------|
| 15/340,448 | 2016.11.01 | US |

(43) Publication Date: **2018.05.11**

(44) Accepted Journal Date: **2023.02.02**

(71) Applicant(s)
Depuy Synthes Products, Inc.

(72) Inventor(s)
Maguire, Paul;Frasier, William

(74) Agent / Attorney
Spruson & Ferguson, GPO Box 3898, Sydney, NSW, 2001, AU

(56) Related Art
US 2016/0256291 A1
US 2011/0320000 A1
US 2008/0147193 A1



(51) International Patent Classification:

A61B 17/56 (2006.01) *A61B 17/70* (2006.01)
A61B 17/58 (2006.01) *A61B 17/88* (2006.01)
A61B 17/68 (2006.01) *A61F 2/44* (2006.01)

(21) International Application Number:

PCT/US2017/058973

(22) International Filing Date:

30 October 2017 (30.10.2017)

(25) Filing Language:

English

(26) Publication Language:

English

(30) Priority Data:

15/340,448 01 November 2016 (01.11.2016) US

(71) Applicant: **DEPUY SYNTHES PRODUCTS, INC.**
[US/US]; 325 Paramount Drive, Raynham, Massachusetts
02767 (US).

(72) Inventors: **MAGUIRE, Paul**; 325 Paramount Drive,
Raynham, Massachusetts 02767 (US). **FRASIER,
William**; 325 Paramount Drive, Raynham, Massachusetts
02767 (US).

(74) Agent: **SHIRTZ, Joseph F.** et al.; Johnson & Johnson,
One Johnson & Johnson Plaza, New Brunswick, New Jersey
08933 (US).

(81) Designated States (*unless otherwise indicated, for every
kind of national protection available*): AE, AG, AL, AM,
AO, AT, AU, AZ, BA, BB, BG, BH, BN, BR, BW, BY, BZ,
CA, CH, CL, CN, CO, CR, CU, CZ, DE, DJ, DK, DM, DO,
DZ, EC, EE, EG, ES, FI, GB, GD, GE, GH, GM, GT, HN,
HR, HU, ID, IL, IN, IR, IS, JO, JP, KE, KG, KH, KN, KP,
KR, KW, KZ, LA, LC, LK, LR, LS, LU, LY, MA, MD, ME,

(54) Title: CURVED EXPANDABLE CAGE

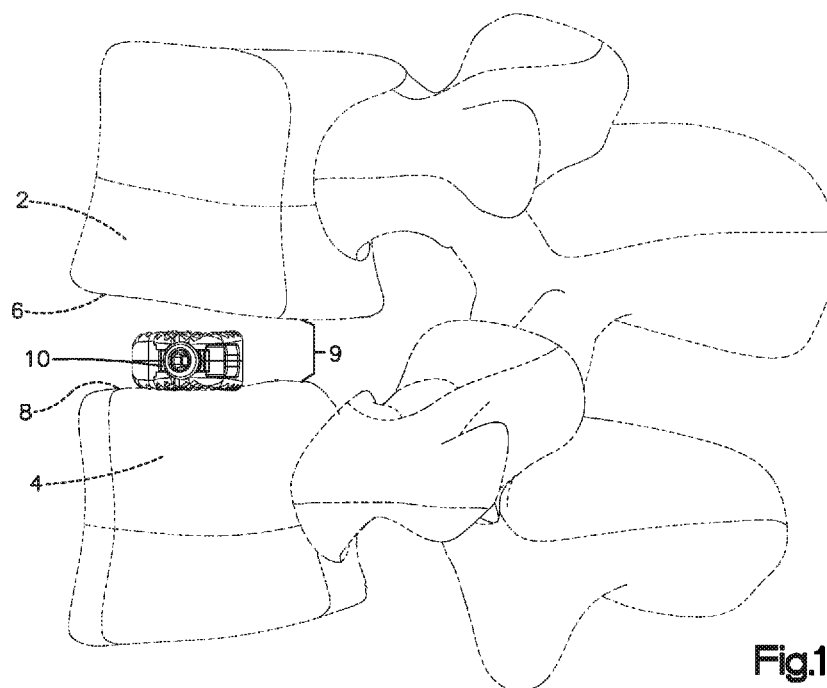

Fig.1

(57) Abstract: An expandable intervertebral implant includes a first endplate and a second endplate, a first wedge member and a second wedge member spaced from the first wedge member that couple the first and second endplates together. The first and second wedge members configured to translate along an actuation member housed between the first and second endplates to cause the implant to expand from a first collapsed configuration into a second expanded configuration. The actuation member has a first threaded section spaced apart from a second threaded section where the first and second threaded sections are at an angle with each other. Between the first and second threaded sections on the actuation member there is a section that permits the first and second threaded sections to rotate in the same rotational direction. The actuation member is configured to move the first and second wedge members from the first collapsed configuration into the second expanded configuration so that the first and second endplates separate from each other to



MG, MK, MN, MW, MX, MY, MZ, NA, NG, NI, NO, NZ, OM, PA, PE, PG, PH, PL, PT, QA, RO, RS, RU, RW, SA, SC, SD, SE, SG, SK, SL, SM, ST, SV, SY, TH, TJ, TM, TN, TR, TT, TZ, UA, UG, US, UZ, VC, VN, ZA, ZM, ZW.

- (84) Designated States** (*unless otherwise indicated, for every kind of regional protection available*): ARIPO (BW, GH, GM, KE, LR, LS, MW, MZ, NA, RW, SD, SL, ST, SZ, TZ, UG, ZM, ZW), Eurasian (AM, AZ, BY, KG, KZ, RU, TJ, TM), European (AL, AT, BE, BG, CH, CY, CZ, DE, DK, EE, ES, FI, FR, GB, GR, HR, HU, IE, IS, IT, LT, LU, LV, MC, MK, MT, NL, NO, PL, PT, RO, RS, SE, SI, SK, SM, TR), OAPI (BF, BJ, CF, CG, CI, CM, GA, GN, GQ, GW, KM, ML, MR, NE, SN, TD, TG).

Declarations under Rule 4.17:

- *as to applicant's entitlement to apply for and be granted a patent (Rule 4.17(ii))*
- *as to the applicant's entitlement to claim the priority of the earlier application (Rule 4.17(iii))*

Published:

- *with international search report (Art. 21(3))*

CURVED EXPANDABLE CAGE

TECHNICAL FIELD

[0001] The present invention relates to an expandable intervertebral implant, system, kit and method.

5 BACKGROUND

[0002] The human spine is comprised of a series of vertebral bodies separated by intervertebral discs. The natural intervertebral disc contains a jelly-like nucleus pulposus surrounded by a fibrous annulus fibrosus. Under an axial load, the nucleus pulposus compresses and radially transfers that load to the annulus fibrosus. The laminated nature of
10 the annulus fibrosus provides it with a high tensile strength and so allows it to expand radially in response to this transferred load.

[0003] In a healthy intervertebral disc, cells within the nucleus pulposus produce an extracellular matrix (ECM) containing a high percentage of proteoglycans. These proteoglycans contain sulfated functional groups that retain water, thereby providing the
15 nucleus pulposus within its cushioning qualities. These nucleus pulposus cells may also secrete small amounts of cytokines such as interleukin-1. beta. and TNF-. alpha. as well as matrix metalloproteinases ("MMPs"). These cytokines and MMPs help regulate the metabolism of the nucleus pulposus cells.

[0004] In some instances of disc degeneration disease (DDD), gradual degeneration
20 of the intervertebral disc is caused by mechanical instabilities in other portions of the spine. In these instances, increased loads and pressures on the nucleus pulposus cause the cells within the disc (or invading macrophages) to emit larger than normal amounts of the above-mentioned cytokines. In other instances of DDD, genetic factors or apoptosis can also cause the cells within the nucleus pulposus to emit toxic amounts of these cytokines and MMPs. In
25 some instances, the pumping action of the disc may malfunction (due to, for example, a decrease in the proteoglycan concentration within the nucleus pulposus), thereby retarding the flow of nutrients into the disc as well as the flow of waste products out of the disc. This reduced capacity to eliminate waste may result in the accumulation of high levels of toxins that may cause nerve irritation and pain.

[0005] As DDD progresses, toxic levels of the cytokines and MMPs present in the
30 nucleus pulposus begin to degrade the extracellular matrix, in particular, the MMPs (as

mediated by the cytokines) begin cleaving the water-retaining portions of the proteoglycans, thereby reducing its water-retaining capabilities. This degradation leads to a less flexible nucleus pulposus, and so changes the loading pattern within the disc, thereby possibly causing delamination of the annulus fibrosus. These changes cause more mechanical instability, thereby causing the cells to emit even more cytokines, thereby upregulating MMPs. As this destructive cascade continues and DDD further progresses, the disc begins to bulge ("a herniated disc"), and then ultimately ruptures, which may cause the nucleus pulposus to contact the spinal cord and produce pain.

[0006] One proposed method of managing these problems is to remove the problematic disc and replace it with a device that restores disc height and allows for bone growth between the adjacent vertebrae. These devices are commonly called fusion devices, or "interbody fusion devices". Current spinal fusion procedures include transforaminal lumbar interbody fusion (TLIF), posterior lumbar interbody fusion (PLIF), and extreme lateral interbody fusion (XLIF) procedures.

SUMMARY

[0007] The present invention relates to expandable intervertebral implants. The expandable intervertebral implants are preferably fusion implants used to fuse two adjacent vertebral bodies in the spine.

[0008] According to an aspect of the present invention, there is provided an expandable implant for insertion into an intervertebral space between a superior vertebral body and an adjacent inferior vertebral body, the expandable implant comprising: a superior endplate having a superior outer surface configured to contact the superior vertebral body; an inferior endplate having an inferior outer surface configured to contact the inferior vertebral body; an actuation member disposed at least partially between the superior and inferior endplates, the actuation member having a first threaded section extending along a first central longitudinal axis of the actuation member and a second threaded section joined to the first threaded section and extending along a second central longitudinal axis of the actuation member, wherein the first central longitudinal axis and the second central longitudinal axis form an angle between about 15° and about 75°; a first wedge member threadedly mated with the first threaded section and a second wedge member threadedly mated with the second threaded section; wherein the actuation member is configured to be rotated about the first and second central longitudinal axes, thereby driving the first wedge member to translate along the first threaded section and the second wedge member to translate along the second threaded section, such that at least one of

the inferior and superior endplates is urged to move away from the other of the inferior and superior endplates from a collapsed implant configuration to an expanded implant configuration, and wherein the actuation member comprises a dual universal joint located between the first threaded section and the second threaded section, the dual universal joint comprising a central narrow, circular flange configured to couple with the inferior endplate and the superior endplate.

[0009] According to one embodiment of the present invention the actuation member comprises a distal end located proximate an insertion end portion of the expandable implant and proximate the second threaded section, and a proximal end located proximate the first threaded section, wherein the dual universal joint causes the second threaded section to rotate in a first rotational direction in response to the first threaded section being rotated in the first rotational direction.

[0009a] According to one embodiment, the first threaded section is oppositely threaded from the second threaded section.

[0009b] According to one embodiment, the first wedge member has a superior inclined surface contacting a first superior ramp surface on an inner surface of the superior endplate.

[0009c] According to one embodiment, the first wedge member has an inferior inclined surface contacting a first inferior ramp surface on an inner surface of the inferior endplate.

[0009d] According to one embodiment, the first central longitudinal axis and the second central longitudinal axis form an angle between about 15° and about 55°.

[0009e] According to one embodiment, the first central longitudinal axis and the second central longitudinal axis form an angle between 30° and 40°.

[0009f] According to one embodiment, the central narrow, circular flange includes a distal flange fork component configured to operatively engage the second threaded section and a proximal flange fork component configured to operatively engage the first threaded section.

[0009g] According to one embodiment, the central narrow, circular flange has a height in a vertical direction greater than a height of the distal flange fork component and greater than a height of the proximal flange fork component.

[0009h] According to one embodiment, the distal flange fork component is connected to a distal center ball component, and the proximal flange fork component is connected to a proximal center ball component.

[0009i] According to one embodiment, the distal center ball component is connected to a distal actuation fork component connected to the second threaded section of the actuation member and the proximal center ball component is connected to a proximal actuation fork component connected to the first threaded section of the actuation member.

[0009j] In another aspect, there is provided a method for inserting an intervertebral implant into an intervertebral space between a superior vertebral body and an adjacent inferior vertebral body, the method comprising:

inserting an expandable implant in a collapsed configuration into the intervertebral space where the expandable implant comprises a superior endplate having a superior outer surface facing the superior vertebral body and an inferior endplate having an inferior outer surface facing the inferior vertebral body;

rotating an actuation member disposed at least partially between the inferior and superior endplates, thereby causing the expandable implant to change from the collapsed configuration to an expanded configuration where at least one of the inferior and superior endplates is moved apart from the other of the inferior and superior endplates in a cranial-caudal direction;

wherein the actuation member comprises a first wedge member threadingly mated with a first threaded section of the actuation member that extends along a first central longitudinal axis and a second wedge member threadingly mated with a second threaded section of the actuation member that is joined with the first threaded section, the second threaded section extending along a second central longitudinal axis of the actuation member, wherein the first central longitudinal axis and the second central longitudinal axis form an angle between 15° and 75° , and

wherein the actuation member comprises a dual universal joint located between the first threaded section and the second threaded section, the dual universal joint comprising a central narrow, circular flange configured to couple with the inferior endplate and the superior endplate.

[0009k] According to one embodiment, the actuation member comprises 1) a distal end located proximate an insertion end portion of the intervertebral implant and proximate the second threaded section, and 2) a proximal end located proximate the first threaded section, and

rotating the first threaded section in a first rotational direction causes the second threaded section to rotate in the first rotational direction.

[0009l] According to one embodiment of the present invention, the first threaded section is oppositely threaded from the second threaded section.

[0009m] According to one embodiment, the first threaded section in the first rotational direction causes the first and second wedge members to move the inferior and superior endplates apart unevenly in the cranial-caudal direction so as cause one of lordotic and kyphotic expansion between the superior and inferior vertebral bodies.

BRIEF DESCRIPTION OF THE DRAWINGS

[0010] The foregoing summary, as well as the following detailed description of illustrative embodiments of the intervertebral implant of the present application, will be better understood when read in conjunction with the appended drawings. For the purposes of illustrating the expandable intervertebral implant of the present application, there is shown in the drawings illustrative embodiments. It should be understood, however, that the application is not limited to the precise arrangements and instrumentalities shown. In the drawings:

[0011] Fig. 1 illustrates an implant positioned between vertebral bodies, according to an embodiment of the present disclosure;

[0012] Fig. 2 is a perspective view of the implant shown in Fig. 1 in a collapsed configuration;

[0013] Fig. 3 is a perspective view of the implant shown in Fig. 1 in an expanded configuration;

[0014] Fig. 4 is an exploded perspective view of the implant shown in Fig. 1;

[0015] Fig. 5 is a perspective view of the inferior endplate of the implant shown in
5 Fig. 1;

[0016] Fig. 6 is side view of the endplate of the implant shown in Fig. 5;

[0017] Fig. 7 is a top plan view of the endplate of the implant shown in Fig. 5;

[0018] Fig. 8 is a bottom plan view of the endplate of the implant shown in Fig. 7;

[0019] Fig. 9 is a perspective view of the superior endplate of the implant shown in
10 Fig. 1;

[0020] Fig. 10 is side view of the endplate of the implant shown in Fig. 9;

[0021] Fig. 11 is a bottom plan view of the endplate of the implant shown in Fig. 9;

[0022] Fig. 12 is a top plan view of the endplate of the implant shown in Fig. 1;

[0023] Fig. 13 is a perspective view of a wedge member of the implant shown in
15 Fig. 1;

[0024] Fig. 14 is a side view of the wedge member illustrated in Fig. 13;

[0025] Fig. 15 is an end view of the wedge member illustrated in Fig. 13;

[0026] Fig. 16 is another end view of the wedge member illustrated in Fig. 13;

[0027] Fig. 17 is a perspective view of the actuation member of the implant shown
20 in Fig. 1;

[0028] Fig. 18 is a perspective view of the actuation member of the implant shown
in Fig. 1;

[0029] Fig. 19 is a top view of the actuation member of the implant shown in Fig. 1;

[0030] Fig. 20 is a side view of the actuation member of the implant shown in Fig.
25 1;

[0031] Fig. 21 is a sectional view of the actuation member of the implant shown in
Fig. 20;

[0032] Fig. 22 is a sectional view of the actuation member of the implant shown in
Fig. 21;

[0033] Fig. 23 is a top view of the implant of Fig. 2 illustrating the implant in the
30 collapsed configuration;

[0034] Fig. 24 is a sectional view of the implant of Fig. 23 taken along line 24–24,
illustrating the implant in the collapsed configuration;

[0035] Fig. 25 is a top view of the implant of Fig. 2 illustrating the implant in the expanded configuration;

[0036] Fig. 26 is a sectional view of the implant of Fig. 25 taken along line 26–26, illustrating the implant in the expanded configuration;

5 [0037] Fig. 27 is a perspective view of another embodiment for the actuation member of the implant shown in Fig. 1;

[0038] Fig. 28 is an exploded view of the actuation member shown in Fig. 27;

[0039] Fig. 29 is a top view of the actuation member shown in Fig. 27;

[0040] Fig. 30 is a side view of the actuation member shown in Fig. 27;

10 [0041] Fig. 31E is a sectional view of the actuation member shown in Fig. 30;

[0042] Fig. 32 is a perspective view of another embodiment for the actuation member of the implant shown in Fig. 1;

[0043] Fig. 33 is an exploded view of the actuation member shown in Fig. 32;

[0044] Fig. 34 is a top view of the actuation member shown in Fig. 32;

15 [0045] Fig. 35 is a side view of the actuation member shown in Fig. 32;

[0046] Fig. 36 is a sectional view of the actuation member shown in Fig. 35;

[0047] Fig. 37 is a perspective view of another embodiment for the actuation member of the implant shown in Fig. 1;

[0048] Fig. 38 is an exploded view of the actuation member shown in Fig. 37;

20 [0049] Fig. 39 is a top view of the actuation member shown in Fig. 37;

[0050] Fig. 40 is a side view of the actuation member shown in Fig. 37;

[0051] Fig. 41 is a sectional view of the actuation member shown in Fig. 40;

[0052] Fig. 42 is a perspective view of another embodiment for the actuation member of the implant shown in Fig. 1;

25 [0053] Fig. 43 is a top view of the actuation member shown in Fig. 42;

[0054] Fig. 44 is a side view of the actuation member shown in Fig. 42;

[0055] Fig. 45 is a sectional view of the actuation member shown in Fig. 42;

DETAILED DESCRIPTION OF ILLUSTRATIVE EMBODIMENTS

[0056] Referring to Fig. 1, a superior vertebral body 2 and an adjacent inferior vertebral body 4 defines an intervertebral space 9 extending between the vertebral bodies 2 and 4. The superior vertebral body 2 defines superior vertebral surface 6, and the adjacent inferior vertebral body 4 defines an inferior vertebral surface 8 (the vertebral surfaces are usually the vertebral endplates that are surgically prepared for accepting the implant). The

vertebral bodies 2 and 4 are commonly anatomically adjacent, but may be the remaining vertebral bodies after an intermediate vertebral body has been removed from a location between the vertebral bodies 2 and 4. The intervertebral space 9 in Fig. 1 is illustrated after a discectomy, whereby the disc material has been removed or at least partially removed to
5 prepare the intervertebral space 9 to receive an intervertebral implant or implant 10, as shown in Figs. 2-3 (the implant may also be referred to as a “spacer” or “fusion spacer” in the technical community). The inserted and expanded implant 10 is designed to achieve an appropriate height restoration for the intervertebral space 9. The intervertebral space 9 can be disposed anywhere along the spine as desired, including at the lumbar, thoracic, and cervical
10 regions of the spine.

[0057] Referring to Figs. 2-3, an embodiment of the present invention is depicted as a TLIF implant 10. The expandable intervertebral implant or implant 10 defines an implant body 13 that defines a distal or insertion end 12 and a proximal or trailing end 14 that is spaced from and opposite the insertion end 12. The implant 10 is designed and configured to
15 be inserted into an intervertebral space in a direction from the trailing end 14 toward the insertion end 12, also referred to herein as an insertion direction. The insertion direction for a TLIF implant is generally not a straight line, but rather a curved path that may be oriented along or approximately along an implant axis that is along the center-width line of the implant 10. The trailing end 14 is configured to couple with one or more insertion
20 instruments, which are configured to support and carry the implant 10 into the intervertebral space 9, and/or actuate the implant 10 from a collapsed configuration C shown in Fig. 2 into an expanded configuration E shown in Fig. 3.

[0058] The implant 10 has a superior endplate or shell 18 and an inferior endplate or shell 20 that are held together and that can expand and contract relative to each other in the
25 transverse direction T to change the height of the implant 10 within the intervertebral space 9. The superior endplate or shell 18 has a superior or outer/upper bone-contacting surface 32 and the inferior endplate or shell 20 has an inferior or outer/lower or second bone contacting surface 132 spaced from the superior bone-contacting surface 32 along the transverse direction T. The superior and inferior bone contacting surfaces 32 and 132 are configured to
30 engage the superior and inferior vertebral bodies 2 and 4, respectively, at the respective vertebral surfaces 6, 8. Each of the superior and inferior bone contacting surfaces 32 and 132 can be convex or partially convex, for instance, one portion of the surface is convex while another portion can be planar; these surfaces can be convex along the length of the implant 10

and also convex along the width in the lateral direction A. The bone contacting surfaces 32 and 132 can also define a texture 41, such as spikes, ridges, pyramid-shapes, cones, barbs, indentations, or knurls, which are configured to engage the superior and inferior vertebral surfaces 6 and 8, respectively, when the implant 10 is inserted into the intervertebral space 9.

5 The bone contacting surfaces 32 and 132 may be partially textured. For instance, the bone contacting surfaces 32 and 132 can include specific patterns of textured and non-textured portions. For a TLIF implant 10 as depicted, the texture 41 can be in the form of parallel, curved ridges 43 that are the peaks of the pyramid-shaped textures depicted in Fig. 2-3, and that are curved in the insertion path direction.

10 **[0059]** As used herein, the term “proximal” and derivatives thereof refer to a direction from the distal or insertion end 12 toward the proximal end 14. As used herein, the term “distal” and derivatives thereof refer to a direction from the proximal end 14 toward the insertion end 12. As used herein, the term “superior” and derivatives thereof refer to a direction from the inferior bone contact surface 132 toward the superior bone-contacting surface 32. As used herein, the term “inferior” and derivatives thereof refer to a direction from the superior bone-contacting surface 32 toward the inferior bone contacting surface 132.

15 **[0060]** Continuing with Figs. 2-4, the implant 10 includes a pair of wedge members coupled to an actuation member 26. The pair of wedge members includes a first wedge member 22 and a second wedge member 24 that in the preferred design function to couple the superior endplate 18 to the inferior endplate 20. The first and second wedge members 22 and 24 can translate along the actuation member 26 so as to move the superior endplate 18 relative to the inferior endplate 20 along the transverse direction T to alter the height of the implant 10; that is, as explained below, the actuation member can be rotated to move the wedge members 22, 24 along the actuation member 26 to raise and to lower the height of the implant 10 (the transverse distance between the superior and inferior bone contacting surfaces 32, 132). In this embodiment, the actuation member 26 has a relatively narrow flange 28 extending from the actuation member 26 along the transverse direction T toward the superior endplate 18 and the inferior endplate 20. In a preferred design, the superior endplate 18 has a superior inner surface 33 and the inferior endplate 20 has an inferior inner surface 133 that in conjunction define a channel 135. The implant 10 is configured such that when the implant 10 is in the collapsed configuration C shown in Fig. 2, a substantial majority of the actuation member 26, at least a portion of first wedge member 22 and at least a portion of the second wedge member 24 are disposed within the channel 135; that is, preferably, only the proximal

end portion 26p of the actuation member 26 is outside the channel 135 and the back portions of the wedge members 22, 24 are outside the channel 135 in the collapsed configuration C.

The implant endplates and/or wedge members can be formed of polyether ether ketone (PEEK) or any other suitable biocompatible polymeric material, or a metal alloy. The

5 actuation member 26 can formed from a biocompatible polymeric material or metallic alloy, such as titanium or steel. It should be appreciated that the any suitable material can be used to form the implant components as described herein. For instance, an entirety of the implant can be made from a titanium alloy. For instance, an entirety of the implant can be made from a titanium-aluminium-niobium (TAN) alloy.

10 **[0061]** Referring to Figs. 4-8, the inferior endplate 20 is configured for coupling with the first wedge member 22, the second wedge member 24, and at least a portion of the flange 28. The inferior endplate 20 can define a cavity 42 configured to partially house the first and second wedge members 22 and 24, and the actuation member 26. The inferior endplate 20 has an inferior inner surface 133 that includes a preferably planar surface 35a that
15 forms the top surface of the two lateral side walls 36i and 40i that can be preferably designed to match up to similarly angled opposing surfaces on the superior endplate 18, and a multi-contoured surface 35b that forms part of the channel 135. The inferior endplate 20 also defines first and second ramp surfaces 44 and 46. The inferior endplate 20 further defines a first side surface 33a and a second side surface 33b opposite the first side surface 33a. The
20 first and second side surfaces 33a and 33b extend between the bone-contacting surface 132 and the top planar surface 35a along the transverse direction T. The inferior endplate 20 thus defines a first sidewall 36i and a second sidewall 40i spaced from the first sidewall 36i along the lateral direction A. As illustrated, the channel 135 extends along the length of the inferior endplate 20 and along the lateral direction A between the opposed first and second sidewalls
25 36i and 40i. In the embodiment shown, the first and second sidewalls 36i and 40i converge with the inferior bone contacting surface 132 to form a tapered insertion end 16 (Fig. 2).

[0062] Continuing with Figs. 4-8, the first and second sidewalls 36i and 40i are configured to receive the flange 28. The first sidewall 36i can define at least one slot, for instance a first slot 52 for receiving a portion of the flange 28 located on the actuation
30 member 26. The first slot 52 is disposed in sidewall 40i at a location between the insertion end 12 and the trailing end 14 of the inferior endplate 20. The sidewall 36i can define at least one or second slot 54 for receiving another portion of the flange 28. The second slot 54 is disposed in the sidewall 36i at a location between the insertion end 12 and the trailing end 14.

The second slot 54 is aligned, for instance laterally aligned, with and opposing the first slot 52 such that each slot 52 and 54 is positioned to receive a portion of the flange 28. The slots 52 and 54 are also configured to mate with the structure of the flange 28. For instance, the slots 52, 54 have an inner profile that is curvilinear and corresponds to the curvilinear profile of the flange 28. In other alternate embodiments, the slots 52 and 54 may have a rectilinear shape. It should be appreciated that the slots 52 and 54 may have any desired shape that can slidingly receive a portion of the flange 28. For example, if the flange 28 has a square profile, the slots 52 and 54 can be configured to mate with the square shaped flange. In alternate embodiments, the walls 36i and 40i can include a plurality of spaced slots spaced apart along the length of the implant 10 and disposed on the sidewalls 36i and 40i to receive a corresponding number of flanges or flanges portions extending from the actuation member 26.

[0063] The inner surface 133 of the inferior endplate 20 is also designed with a feature to couple the wedge members 22, 24 with the endplate. In one embodiment, along inner walls 39i, 45i of the sidewall 36i and 40i, respectively, there is a groove 37i cut into the inner walls 39i, 45i in the lateral direction A. The grooves 37i are configured to engage a corresponding tab portion of the first and second wedge members 22 and 24 as further detailed below. The inferior endplate 20 has four grooves 37i that are in two sets of pairs. The grooves 37i extend in a parallel fashion to the ramp surfaces 44, 46 along the length of the implant 10. The pair of grooves 37i on the first side 3 of the inferior endplate 20 extend from a point adjacent the trailing end 14 toward the middle section 7 of the implant 10 and parallel ramp surface 46 in a direction toward the inferior surface 132 in the transverse direction T. In a similar fashion, on the opposite second side 5 of the implant, the pair of grooves 37i extend from a point adjacent the insertion end 12 toward the middle section 7 of the implant 10 and parallel ramp surface 44 in a direction toward the inferior surface 132 in the transverse direction T. The grooves 37i extend toward the middle section 7 and terminate at a point either at the longitudinal center, or near the longitudinal center of the implant 10 or if a flange 28 is present, preferably before the slots 52, 54. While each side 3, 5 is illustrated as having a pair of grooves 37i, each side 3, 5 can have a single groove, or more than two grooves or other form of recess to capture the wedge members 22, 24.

[0064] Continuing with Figs. 4-8, the inferior endplate 20 defines ramp surfaces 44 and 46, for instance a first ramp surface 44 and a second ramp surface 46 that are configured to mate with and slide along portions of the first and second wedge members 22 and 24. The

first ramp surface 44 extends from a point proximate the insertion end 12 toward the middle section 7 on an angle toward the inferior bone contacting surface 132. The ramp surface 44 is declined to abut and slidably receive a portion of the second wedge member 24. The second ramp surface 46 extends from a point proximate the trailing end 14 toward the middle section 7 on an angle toward the inferior bone contacting surface 132, and is declined to abut and slidably receive a portion of the first wedge member 22. The ramps surfaces 44 and 46 also extend laterally along the lateral direction A between the opposing first and second walls 36i and 40i. Each ramp surface 44 and 46 can define a ramp angle β (not shown) defined with respect to planar surface 35a. It should be appreciated that the angle β can vary as needed, and preferably is between about 10° and about 65° . The inferior endplate 20 can also define a curvilinear portion 48 disposed at the trailing end 14 that is cut into the second ramp surface 46. The curvilinear portion 48 is configured to align with a corresponding curvilinear portion on the superior endplate 18. When the endplates 18 and 20 are in the collapsed configuration as shown in Fig. 2, the curvilinear portions define an access opening 50 that provides access to the actuation member 26, as further detailed below.

[0065] As shown in Figs. 9-12, the superior endplate 18 is configured similarly to the inferior endplate 20. The superior endplate 18 thus includes similar structural features that correspond to the structural features described above with respect to the inferior endplate 20. The two endplates are designed to close against each other and house the actuation member 26 with the wedge members 22, 24 connected thereto. The superior endplate 18 is configured for coupling with the first wedge member 22, the second wedge member 24, and at least a portion of the flange 28. The superior endplate 18 can define a cavity 42 configured to partially house the first and second wedge members 22 and 24, and the actuation member 26. The superior endplate 18 has a superior inner surface 33 that includes a preferably planar surface 35a that forms the top surface of the two lateral side walls 36s and 40s that can be preferably designed to match up to similarly angled opposing surfaces on the inferior endplate 20, and a multi-contoured surface 35b that forms part of the channel 135. The superior endplate 18 also defines first and second ramp surfaces 44 and 46. The superior endplate 18 further defines a first side surface 33a and a second side surface 33b opposite the first side surface 33a. The first and second side surfaces 33a and 33b extend between the bone-contacting surface 32 and the top planar surface 35a along the transverse direction T. The superior endplate 18 thus defines a first sidewall 36s and a second sidewall 40s spaced from the first sidewall 36s along the lateral direction A. As illustrated, the channel 135

extends along the length of the superior endplate 18 and along the lateral direction A between the opposed first and second sidewalls 36s and 40s. In the embodiment shown, the first and second sidewalls 36s and 40s converge with the superior bone contacting surface 32 to form a tapered insertion end 16 (Fig. 2).

5 **[0066]** Continuing with Figs. 9-12, the first and second sidewalls 36s and 40s are configured to receive the flange 28. The first sidewall 36s can define at least one slot, for instance a first slot 52 for receiving a portion of the flange 28 located on the actuation member 26. The first slot 52 is disposed in sidewall 40s at a location between the insertion end 12 and the trailing end 14 of the superior endplate 18. The sidewall 36s can define at
10 least one or second slot 54 for receiving another portion of the flange 28. The second slot 54 is disposed in the sidewall 36s at a location between the insertion end 12 and the trailing end 14. The slot 54 is aligned, for instance laterally aligned, with and opposing the slot 52 such that each slot 52 and 54 is positioned to receive a portion of the flange 28. The slots 52 and 54 are also configured to mate with the structure of the flange 28. For instance, the slots 52,
15 54 have an inner profile that is curvilinear and corresponds to the curvilinear profile of the flange 28. In other alternate embodiments, the slots 52 and 54 may have a rectilinear shape. It should be appreciated that the slots 52 and 54 may have any desired shape that can slidingly receive a portion of the flange 28. For example, if the flange 28 has a square profile, the slots 52 and 54 can be configured to mate with the square shaped flange. In
20 alternate embodiments, the walls 36s and 40s can include a plurality of spaced slots spaced apart along the length of the implant 10 and disposed on the sidewalls 36s and 40s to receive a corresponding number of flanges or flanges portions extending from the actuation member 26.

[0067] The inner surface 33 of the superior endplate 18 is also designed with a
25 feature to couple the wedge members 22, 24 with the endplate. In one embodiment, along inner walls 39s, 45s of the sidewall 36s and 40s, respectively, there is a groove 37s cut into the inner walls 39s, 45s in the lateral direction A. The grooves 37s are configured to engage a corresponding tab portion of the first and second wedge members 22 and 24 as further detailed below. The superior endplate 18 has four grooves 37s that are in two sets of pairs.
30 The grooves 37s extend in a parallel fashion to the ramp surfaces 44, 46 along the length of the implant 10. The pair of grooves 37s on the first side 3 of the superior endplate 18 extend from a point adjacent the trailing end 14 toward the middle section 7 of the implant 10 and parallel ramp surface 46 in a direction toward the superior surface 32 in the transverse

direction T. In a similar fashion, on the opposite second side 5 of the implant, the pair of grooves 37s extend from a point adjacent the insertion end 12 toward the middle section 7 of the implant 10 and parallel ramp surface 44 in a direction toward the superior surface 32 in the transverse direction T. The grooves 37s extend toward the middle section 7 and terminate at a point near the longitudinal center of the implant 10, and if the flange 28 is present in the design then preferably before the slots 52, 54. While each side 3, 5 is illustrated as having a pair of grooves 37s, each side 3, 5 can have a single groove, or more than two grooves or other form of recess to capture the wedge members 22, 24.

[0068] Continuing with Figs. 9-12, the superior endplate 18 defines ramp surfaces 44 and 46, for instance a first ramp surface 44 and a second ramp surface 46 that are configured to mate with and slide along portions of the first and second wedge members 22 and 24. The first ramp surface 44 extends from a point proximate the insertion end 12 toward the middle section 7 on an angle toward the superior bone contacting surface 32. The first ramp surface 44 is inclined to abut and slidably receive a portion of the second wedge member 24. The second ramp surface 46 extends from a point proximate the trailing end 14 toward the middle section 7 on an angle toward the superior bone contacting surface 32, and is inclined to abut and slidably receive a portion of the first wedge member 22. The ramp surfaces 44 and 46 also extend laterally along the lateral direction A between the opposing first and second walls 36s and 40s. Each ramp surface 44 and 46 can define a ramp angle β (not shown) defined with respect to planar surface 35a. It should be appreciated that the angle β can vary as needed, and preferably is between about 10° and about 65° . The superior endplate 18 can also define a curvilinear portion 48 disposed at the trailing end 14 that is cut into the second ramp surface 46. The curvilinear portion 48 is configured to align with a corresponding curvilinear portion on the inferior endplate 20. When the endplates 18 and 20 are in the collapsed configuration as shown in Fig. 2, the curvilinear portions define an access opening 50 that provides access to the actuation member 26, as further detailed below.

[0069] The superior and inferior endplates 18, 20 are designed to be mated together. In a preferred embodiment, the two endplates are mated together by the wedge members 22, 24 that track within the grooves 37. The planar surfaces 35a of the superior and inferior endplates 18, 20 are designed to contact, or come close to contact, with each other when the implant is in its collapsed position (Fig. 2). The superior endplate 18 and inferior endplate 20 can define opposing indentations 98 at the trailing end 14 of the implant 10. The indentations 98 are configured to receive a portion of an insertion tool (not shown).

[0070] The superior endplate 18 and inferior endplate 20 can also define respective openings or through-holes 30. Each opening or through-hole 30 has been configured to receive at least a portion of the first and second wedge members 22 and 24 to maximize the compact design and the expansion characteristics of the implant 10. The openings 30
5 partially receive portions of the first and second wedge members 22 and 24 when the implant 10 is in the collapsed configuration C (Fig. 2), which allows for the dimensions of the first and second wedge members 22 and 24 to be increased over wedge members used in implants without an opening 30 configured to permit a portion of the wedge member to extend
10 therethrough. Thus, the implant 10 has a collapsed configuration that is compact and less invasive, and an expanded configuration that is dimensionally stable. The openings 30 have the additional benefit of promoting bone growth when implanted in the intervertebral space 9. The opening 30 extends through the superior endplate 18 and similarly through the inferior endplate.

[0071] Referring to Figs. 4 and 13-16, the first wedge member 22 and the second
15 wedge member 24 are configured for slidable coupling to the superior and inferior endplates 18 and 20. The first and second wedge members 22 and 24 are configured similarly, and for illustrative purposes, only the first wedge member 22 will be described below. The first wedge member 22 defines a wedge body 74 extending along a central wedge axis CL
20 between a narrow, outer end 75 and a wider, inner end 76 spaced from the outer end 75 along the central wedge axis CL. The wedge axis CL is preferably aligned with the central axis of the actuation member 26 and extends along the length of the wedge (in the embodiment shown, the implant 10 is designed to expand evenly in the superior and inferior directions because the wedges are designed in a symmetric fashion; the wedge could be designed with
25 different angles for the wedge faces (and even one side could be designed with a flat face) so that expansion can be uneven in the superior and inferior directions). As show in Figs. 4 and 24, the first wedge narrow end 75 is positioned facing toward the outer or trailing end 14 of the implant 10, while the inner wide end 76 is positioned to face the middle portion 7 (and opening 30) of the implant 10. Further, the second wedge member 24 has a wedge body
30 wherein the narrow outer end 75 is positioned facing toward the distal or insertion end 12 of the implant 10 and the inner wide end 76 is positioned facing toward the middle portion 7 (and opening 30) of the implant.

[0072] The wedge body 74 rides along and on the actuation member 26 to provide a mechanical means to separate the superior and inferior endplates 18, 20 to expand the implant

10. The wedge body 74 has a superior surface 77 and an opposing inferior surface 78. The superior surface 77 is angled from the narrow end 75 to the wide end 76, and the inferior surface 78 is similarly angled in the opposite direction. That angle is preferably between about 10° and about 65° with respect to the central axis CL for the superior surface 77 (and oppositely angled for the opposing surface 78). The angle preferably matches the angle for ramp surfaces 44, 46 and also the angle for the grooves 37. The wedge body 74 has protrusions, tabs, or tongues 82 extending along the sides 79, 80; the protrusions 82 are designed to fit and track within the grooves 37 such that as the wedge body 74 tracks along the actuation member 26 and the wedge members 22, 24 translate along the actuation member 26 away from the middle portion 7 the wedge members 22, 24 force the superior and inferior endplates 18, 20 away from each other relatively to cause the implant 10 to move from its collapsed position to its expanded position. The wedge body 74 has a superior edge 76s and an inferior edge 76i that define a height H1 for the wedge. The wedge body 74 has a central bore 81 that is preferably internally threaded to mate with the external threading on the actuation member 26.

[0073] Referring now to Figs. 17-22, an embodiment for the actuation member 26 is depicted for description purposes. The actuation member 26 is configured to couple the first and second wedge members 22 and 24 together while also providing stability to the superior endplate 18 and inferior endplate 20 during implant expansion. The actuation member 26 is angled or curved at its middle section 90 that separates a second threaded section 91 and a first threaded section 92, the threaded sections 91, 92 having threads 99. The second threaded section 91 preferably is constructed such that there is a length of threaded straight rod having a center longitudinal axis CL1, and similarly the first threaded section 92 preferably is constructed such that there is a length of threaded straight rod having a center longitudinal axis CL2 (see Fig. 21). The two center longitudinal axis lines CL1 and CL2 form an angle, α , between them where the angle α is preferably between about 15° and about 75°; more preferably between about 15° and about 55°; more preferably between about 20° and about 50°; more preferably between about 25° and about 45°; more preferably between 30° and 40°, and in some embodiments between 33° and 37°. It is preferred that the first and second threaded sections 91, 92 each extend along a respective straight longitudinal section of the actuation member; however, the first and second threaded sections 91, 92 could be non-straight. In this latter configuration, a line can be drawn between a point in the center of the actuation member 26 at the beginning and at the end of the threads 99 on each of the first

and second threaded sections 91, 92. The angle between these two lines would then form angle α . The first and second threaded sections 91, 92 are preferably formed from steel, a titanium alloy, cobalt chrome, nitinol, polymers, or combinations of the foregoing materials.

[0074] In the embodiment depicted, the middle section 90 of the actuation member 5 26 can be constructed to include a flexible rod, which in this instance is in the form of a cable 93 that is made up of several wire segments 94. The middle section 90 is thus flexible and can enable the actuation member 26 to be rotated at one end by an actuation tool and that rotation will be maintained evenly for both the first and section threaded sections 91, 92. The pitch for the threads 99 on the first threaded section 92 is preferably the same as the pitch on 10 the threads 99 on the second threaded section 91, except that the pitch is opposite hand between the first and second threaded section 91, 92. In this regard, the internal threads within the bores 81 for the first and second wedge members 22, 24 are designed to mate with the respective threads of the respective first and second threaded sections 91, 92, and are thus also opposite handed such that when the actuation member 26 rotates, the first and second 15 wedge members 22 and 24 translate along the actuation member 26 toward each other or away from each depending on the rotation direction of the actuation member 26. The thread pattern on each threaded section 91, 92 may have the same pitch such that the first and second wedge members 22 and 24 can translate along the actuation member 26 at the same rate. The thread pitch can be different if needed when different distraction profiles are 20 desired in the expanded configuration (e.g. kyphotic or lordotic). The proximal end 26p of the actuation member 26 can define a socket 26e configured to receive or support a portion of an insertion instrument, as further detailed below. The socket 26e can have any configuration as need to receive an instrument, such as hex, Phillips, flat, star, square, etc.

[0075] Thus, the shaft 95 of the actuation member 26 is curved along its length and 25 defines a second threaded section 91 disposed distally relative to the flange 28 (or in the second side 5 proximate the insertion end 12), and a first threaded section 92 disposed proximally from the flange 28 (or in the first side 3 proximate the trailing end 14). The shaft 95 can have a length L1 extending from a distal end 96 along a central axis CA extending along the center of the shaft (see Fig. 17) to a proximal end 97, where the length L1 can 30 extend between about 24 to about 32 mm. The length of each of the first and second threaded sections 91, 92 is preferably equal, but can be different, and is preferably between about 6 mm to about 12 mm, more preferably between about 8 mm to about 9 mm. The length of middle section 90, which extends between the first and second threaded sections 91, 92 is

preferably between about 8 mm to about 13 mm, more preferably between about 9 mm to about 11 mm. As shown in Figs. 17-21, the middle section 90 is constructed with a first cable section 93a extending between the second threaded section 91 and the flange 28 and a second cable section 93b extending between the first threaded section 92 and the flange 28.

5 The length of each of the first and second cable sections 93a, 93b is preferably about equal, but can be different, and preferably is each from about 4 mm to about 7 mm long, and more preferably from about 4.5 mm to about 5.5 mm long along the central axis CA (see Fig. 17). The flange 28 is preferably about 2 mm to about 5 mm long along the central axis CA between faces 28a, 28b, and preferably about 2 mm to about 3 mm in height between faces
10 28c, 28d (see Fig. 21).

[0076] As seen in Figs. 2-3 and 23-26, the implant 10 can have initial dimensions and expanded dimensions. For instance, the implant can have first implant height D1 defined between the opposing first and second bone contacting surfaces 32 and 132 when the implant is in its collapsed position C, and second implant height D2 defined between the opposing
15 first and second bone contacting surfaces 32 and 132 when the implant is in its expanded position E. The distance is measured from the surfaces 32, 132, and not from the tops of any textures 41 (teeth, etc.) that are commonly used with such surfaces. In an embodiment, the first implant height D1 can range between about 7 mm and 15 mm, preferably between about 7 mm and 10 mm, and the second expanded implant height D2 can range between about 10
20 mm and 20 mm, preferably between about 10 mm and 13 mm. In the expanded position E, the opposed superior and inferior inner planar surfaces 35a, which in the collapsed position C preferably abut one another, can be spaced apart any distance as desired within the stated range, such as between about 3 mm and 5 mm. For instance, in one embodiment, the first height D1 can be 7 mm while the expanded, second height D2 can be 10 mm. In another
25 embodiment, the first height D1 can be 9 mm and the expanded, second height D2 can be 13 mm. Other dimensions are possible as well. For example first heights can be up to 7 mm, 9 mm, or greater. The implant 10 also has a width, and in one embodiment, the first and second bone contacting surfaces 32 and 132 can define a dimension in the lateral direction A as desired, such as between 8 mm and 12 mm.

[0077] The overall system includes one or more insertion tools. An insertion tool
30 can include a handle and a shaft extending from the handle toward an implant supporting end. The implant supporting end can be configured to support, for instance carry or engage with a portion of the implant 10. The implant supporting end can include spaced apart tabs

configured and sized to be received in the implant indentations 98. When the implant tabs engage the indentations 98, the tool can position and/or insert the implant 10 into the intervertebral space 9. An additional tool can be used to expand the implant 10 from the collapsed configuration C to the expanded configuration E. This tool can include a handle
5 and a shaft extending from the handle toward a working end configured to engage the proximal end 26p of the actuation member 26, such that rotation of the tool can cause rotation of the actuation member 26.

[0078] Referring to Figs. 23-26, implant 10 is configured to expand from the collapsed configuration C (Fig. 24) to the expanded configuration E (Fig. 26). When in the
10 first or collapsed configuration C, the first and second wedge members 22 and 24 are disposed in the implant such that the inner ends 76 face and are spaced apart from each other to define a gap therebetween extending over the middle section 90. The first and second wedge members 22, 24 are threaded onto the actuation member 26 such that the first threaded section 92 is disposed within the bore 81 of the first wedge member 22 and the second
15 threaded portion 91 is disposed within the bore 81 of the second wedge member 24. In the collapsed position C, the wedge members 22, 24 are preferably located near or at the inner ends 61 of the threaded sections 91, 92, and are spaced apart from the sides 28a, 28b of the flange. The inclined surfaces 77 and 78 of the wedge members 22, 24 are adjacent to opposing ramp surfaces 44 and 46 of the respective inferior and superior endplates 20, 18. In
20 one embodiment, the inner end superior edge and inferior edges 76s and 76i extend into the opening 30 and can be located within or above/below a plane containing the bone contacting surfaces 32, 132. Portions of the first and second wedge members 22 and 24, for instance edges 76s, 76i, disposed in the opening 30 allows for a wedge profile that aids the endplates 18 and 20 separation with relatively little advancement of the first and second wedge
25 members 22 and 24 along the actuation member 26.

[0079] When the actuation member 26 is rotated via a tool engaged at the proximal end 26p, the first threaded portion 92 of the actuation member 26 causes the first wedge member 22 to translate toward the trailing end 14 of the implant 10. The inclined surfaces 77 and 78 bear against the ramp surfaces 44 and 46 to separate the superior endplate 18 from the
30 inferior endplate 20 along the transverse direction to move the implant 10 from the collapsed position C to the expanded position E. The protrusions or tabs 82 of the first wedge member 22 slide along the grooves 37i, 37s in a controlled manner. In conjunction, because the middle portion 90 of the actuation member 26 is a flexible cable, at the same time while the

first wedge member 22 is translating toward the implant trailing end 14, the second threaded portion 91 of the actuation member 26 engages the bore 81 of the second wedge member 24 and causes the second wedge member 24 to translate toward the insertion end 12 of the implant 10. Again, the inclined surfaces 77 and 78 of the second wedge member 24 slide
5 along the ramp surfaces 44 and 46 so as to separate the superior endplate 18 from the inferior endplate 20 along the transverse direction T. Again, the protrusions or tabs 82 of the second wedge member 24 slide along respective grooves 37s, 37i. The flange 28 remains disposed in the slots 52, 54 during actuation of the implant 10 and provides additional stability against shear when the implant 10 is expanded. The embodiment shown in Figs. 23-26 illustrates the superior endplate 18 separating from the inferior endplate 20 along a transverse direction T
10 while remaining generally parallel to each other. In other alternate embodiments, the implant can be configured to such that a lordotic or kyphotic distraction is achieved. For example, the threaded portions of the actuation member can be configured to cause one wedge member to translate at a faster rate compared to the other wedge member. In such an embodiment, when
15 the implant 10 is expanded, the superior endplate 18 will be angularly offset from the inferior endplate 20.

[0080] The implant 10 can be used in TLIF surgical procedures. In general terms, the intervertebral disc space 9 is prepared by removing the appropriate amount of natural disc material to the surgeon's preference and preparing the endplate vertebral surfaces 6, 8 for
20 receiving the implant 10. The implant 10 is inserted into the intervertebral space 9 defined between a superior vertebral body 2 and an inferior vertebral body 4. Preferably, the intervertebral implant 10 is inserted into the intervertebral space 9 in the fully collapsed configuration, although the implant 10 could be slightly expanded. The method further includes the step of expanding the intervertebral implant 10 from a collapsed configuration to
25 a final expanded configuration. When the implant 10 is in the collapsed configuration, the first and second bone contacting surfaces 32 and 132 are spaced from each other a first distance in the transverse direction T.

[0081] As described above, the actuation member 26 is rotatable about its central axis CA to cause the implant 10 to expand from a collapsed configuration to an expanded
30 configuration. As described above, a tool is used to rotate the actuation member 26 to cause the first and second wedge members 22 and 24 translate along the actuation member 26 and to move away from each other to expand the implant 10. The actuation member 26 can be rotated until the first wedge member 22 abuts a stop member 63, which prevents further

rotation of the actuation member 26 in the expansion direction. The stop member 63 can be a ring that has a threaded internal bore and that is placed onto the first threaded section 92 after the first wedge member 22 is assembled onto the implant 10. The actuation member 26 is rotatable in a contraction direction opposite the expansion direction so as to cause the wedge members 22 and 24 to move toward each other, thereby moving the endplates 18 and 20 toward each other in a direction from an expanded position toward a collapsed configuration. The implant 10 thus can be expanded in the cranial-caudal or superior-inferior direction, the transverse direction T, to engage the adjacent vertebral bodies 2, 4.

[0082] There are other mechanical components that can be used in the present invention to provide for the simultaneous rotation of the first and second threaded sections 91 and 92 of the actuation member 26 to cause the first and second wedge members 22, 24 to simultaneously expand the implant 10 by imparting a rotational force upon the actuation member 26 at its proximal end 26p. For example, in Figs. 27-31, a dual universal joint embodiment is shown for the actuation member 26. The dual universal joint 102 is located in the middle section 90 of the actuation member 26. The dual universal joint 102 is constructed with a first universal joint assembly 107 and a second universal joint assembly 108. The first universal joint assembly 107 has a fork 103a coupled to the first threaded section 92, preferably integrally formed with the first threaded section 92. The fork 103a is coupled to a center block (or ball) 104a by way of pins 106a that extend through opposed openings 109a in the fork 103a. The center block 104a is also coupled to center fork 105a by way of pins 106a that extend through openings 109a. The second universal joint assembly 108 has a fork 103b coupled to the second threaded section 91, preferably integrally formed with the second threaded section 91. The fork 103b is coupled to a center block 104b by way of pins 106b that extend through opposed openings 109b in the fork 103b. The center block 104b is also coupled to center fork 105b by way of pins 106b that extend through openings 109b. In this embodiment, the dual universal joint 102 along with the first and second threaded sections 92, 91 form the actuation member 26 for the implant 10. Apart from the mechanical mechanism for permitting the simultaneous rotation of the two threaded sections 91, 92 being different between this dual universal joint 102 embodiment and the flexible cable 93 embodiment in Figs. 2-26, the remaining parts and function of the implant are the same. In that regard, when the actuation member 26 having the dual universal joint 102 is used in the implant the angle between the first threaded section 91 and the second threaded section 92 is the same as described above with the flexible cable 93 embodiment.

[0083] Another embodiment for the actuation member 26 is shown in Figs. 32-36, a turn buckle embodiment. The turn buckle 112 is located in the middle section 90 of the actuation member 26. The turn buckle 112 is constructed with a first inner end 113a coupled to the first threaded section 92, preferably integrally formed with the first threaded section 92.

5 The first inner end 113a is partially threaded with threads 99 but is cut along its two sides 116a to form a reduced profile loop section and the sides 116a have a hole 119a. An inner shaft 114a also has a loop section with a hole 115a. The hole 119a of the inner end 113a receives the loop section of the inner shaft 114a and the hole 115a of the inner shaft 114a receives the loop section of the inner end 113a to form part of the turn buckle 112 on the first

10 threaded section 92 side of the actuation member 26. The turn buckle 112 is further constructed with a second inner end 113b coupled to the second threaded section 91, preferably integrally formed with the second threaded section 91. The second inner end 113b is partially threaded with threads 99 but is cut along its two sides 116b to form a reduced profile loop section and the sides 116b have a hole 119b. An inner shaft 114b also has a loop

15 section with a hole 115b. The hole 119b of the inner end 113b receives the loop section of the inner shaft 114b and the hole 115b of the inner shaft 114b receives the loop section of the inner end 113b to form part of the turn buckle 112 on the second threaded section 91 side of the actuation member 26. In this embodiment, the turn buckle 112 along with the first and second threaded sections 92, 91 form the actuation member 26 for the implant 10. Apart

20 from the mechanical mechanism for permitting the simultaneous rotation of the two threaded sections 91, 92 being different between this turn buckle 112 embodiment and the flexible cable 93 embodiment in Figs. 2-26, the remaining parts and function of the implant are the same. In that regard, when the actuation member 26 having the turn buckle 112 is used in the implant the angle between the first threaded section 91 and the second threaded section 92 is

25 the same as described above with the flexible cable 93 embodiment.

[0084] Still another embodiment for the actuation member 26 is shown in Figs. 37-41, a universal joint embodiment. The universal joint 122 is located in the middle section 90 of the actuation member 26. The universal joint 122 is constructed with a fork 123a coupled to the first threaded section 92, preferably integrally formed with the first threaded section 92.

30 The fork 123a is coupled to a center block (or ball) 124 by way of pins 126 that extend through opposed openings 129a in the fork 123a. The center block 124 is also coupled to opposing fork 123b by way of pins 126 that extend through openings 129b. The fork 123b coupled to the second threaded section 91, preferably integrally formed with the second

threaded section 91. In this embodiment, the universal joint 122 along with the first and second threaded sections 92, 91 form the actuation member 26 for the implant 10. Apart from the mechanical mechanism for permitting the simultaneous rotation of the two threaded sections 91, 92 being different between this universal joint 122 embodiment and the flexible cable 93 embodiment in Figs. 2-26, the remaining parts and function of the implant are the same, except that the flange 28 is not present in the embodiment as shown. In that regard, when the actuation member 26 having the universal joint 122 is used in the implant the angle between the first threaded section 91 and the second threaded section 92 is the same as described above with the flexible cable 93 embodiment.

10 **[0085]** Yet another drive mechanism that can form the basis for another embodiment for the actuation member 26 is shown in Figs. 42-45, a dual wired cylinder embodiment. The dual wired cylinder 142 is also a flexible rod like the cable 93 embodiment and is located in the middle section 90 of the actuation member 26. The dual wired cylinder 142 is constructed with a first wired cylinder 143a coupled to the first threaded section 92, preferably integrally formed with the first threaded section 92. The first wired cylinder 143a is preferably formed from surgical grade metal alloy such as a titanium alloy as a wire turned to form a cylinder shape. At its opposite end, the first wired cylinder 143a is connected to a second wired cylinder 143b that is connected at its opposite end to the second threaded section 91. The flange 28 can optionally be formed between the first and second wired cylinders 143a,b as shown. In this embodiment, the dual wired cylinder 142 along with the first and second threaded sections 92, 91 form the actuation member 26 for the implant 10. Apart from the mechanical mechanism for permitting the simultaneous rotation of the two threaded sections 91, 92 being different between this dual wired cylinder 142 embodiment and the flexible cable 93 embodiment in Figs. 2-26, the remaining parts and function of the implant are the same. In that regard, when the actuation member 26 having the dual wired cylinder 142 is used in the implant the angle between the first threaded section 91 and the second threaded section 92 is the same as described above with the flexible cable 93 embodiment.

25 **[0086]** Each of the superior endplate 18 and inferior endplate 20 can include one or more radiographic markers. The implant 10 can define one or more bores (not shown) sized and dimensioned to receive a radiographic marker therein. For example, a radiographic marker can be disposed near the nose 16 in either the superior endplate 18 or the inferior endplate 20, or both. The markers can thus identify the location of the nose 16 of the implant

and also the extent of expansion of the implant 10 when the markers are located in each endplate. For example, when the implant 10 is inserted into the intervertebral space 9, and the implant 10 is expanded from the first configuration C to the expanded configuration E, the markers can separate along the transverse direction T. With image analysis, the extent of plate separation can be determined or indicated by observing the extent of separation between the markers disposed in the superior endplate 18 compared to the marker disposed in the inferior endplate 20.

[0087] Although the disclosure has been described in detail, it should be understood that various changes, substitutions, and alterations can be made herein without departing from the spirit and scope of the invention as defined by the appended claims. Moreover, the scope of the present disclosure is not intended to be limited to the particular embodiments described in the specification. As one of ordinary skill in the art will readily appreciate from that processes, machines, manufacture, composition of matter, means, methods, or steps, presently existing or later to be developed that perform substantially the same function or achieve substantially the same result as the corresponding embodiments described herein may be utilized according to the present disclosure.

[0088] Any reference to prior art in this specification is not to be taken as an admission such prior art forms part of the common general knowledge in Australia or any other country.

[0089] Throughout the specification the word “comprise” is to be construed in an inclusive sense is so far as other features or integers may be added or combined with the features or integers described and/or defined in the claims.

CLAIMS:

1. An expandable implant for insertion into an intervertebral space between a superior vertebral body and an adjacent inferior vertebral body, the expandable implant comprising:
 - a superior endplate having a superior outer surface configured to contact the superior vertebral body;
 - an inferior endplate having an inferior outer surface configured to contact the inferior vertebral body;
 - an actuation member disposed at least partially between the superior and inferior endplates, the actuation member having a first threaded section extending along a first central longitudinal axis of the actuation member and a second threaded section joined to the first threaded section and extending along a second central longitudinal axis of the actuation member, wherein the first central longitudinal axis and the second central longitudinal axis form an angle between about 15° and about 75° ;
 - a first wedge member threadedly mated with the first threaded section and a second wedge member threadedly mated with the second threaded section;
 - wherein the actuation member is configured to be rotated about the first and second central longitudinal axes, thereby driving the first wedge member to translate along the first threaded section and the second wedge member to translate along the second threaded section, such that at least one of the inferior and superior endplates is urged to move away from the other of the inferior and superior endplates from a collapsed implant configuration to an expanded implant configuration, and
 - wherein the actuation member comprises a dual universal joint located between the first threaded section and the second threaded section, the dual universal joint comprising a central narrow, circular flange configured to couple with the inferior endplate and the superior endplate.
2. The expandable implant of claim 1, wherein the actuation member comprises a distal end located proximate an insertion end portion of the expandable implant and proximate the second threaded section, and a proximal end located proximate the first threaded section, wherein the dual universal joint causes the second threaded section to rotate in a first rotational direction in response to the first threaded section being rotated in the first rotational direction.
3. The expandable implant of claim 1, wherein the first threaded section is oppositely threaded from the second threaded section.

4. The expandable implant of claim 1, wherein the first wedge member has a superior inclined surface contacting a first superior ramp surface on an inner surface of the superior endplate.
5. The expandable implant of claim 4, wherein the first wedge member has an inferior inclined surface contacting a first inferior ramp surface on an inner surface of the inferior endplate.
6. The expandable implant of claim 1, wherein the first central longitudinal axis and the second central longitudinal axis form an angle between about 15° and about 55°.
7. The expandable implant of claim 1, wherein the first central longitudinal axis and the second central longitudinal axis form an angle between 30° and 40°.
8. The expandable implant of claim 2, wherein the central narrow, circular flange includes a distal flange fork component configured to operatively engage the second threaded section and a proximal flange fork component configured to operatively engage the first threaded section.
9. The expandable implant of claim 8, wherein the central narrow, circular flange has a height in a vertical direction greater than a height of the distal flange fork component and greater than a height of the proximal flange fork component.
10. The expandable implant of claim 8, wherein the distal flange fork component is connected to a distal center ball component, and the proximal flange fork component is connected to a proximal center ball component.
11. The expandable implant of claim 10, wherein the distal center ball component is connected to a distal actuation fork component connected to the second threaded section of the actuation member and the proximal center ball component is connected to a proximal actuation fork component connected to the first threaded section of the actuation member.
12. A method for inserting an intervertebral implant into an intervertebral space between a superior vertebral body and an adjacent inferior vertebral body, the method comprising:
inserting an expandable implant in a collapsed configuration into the intervertebral space where the expandable implant comprises a superior endplate having a superior outer surface

facing the superior vertebral body and an inferior endplate having an inferior outer surface facing the inferior vertebral body;

rotating an actuation member disposed at least partially between the inferior and superior endplates, thereby causing the expandable implant to change from the collapsed configuration to an expanded configuration where at least one of the inferior and superior endplates is moved apart from the other of the inferior and superior endplates in a cranial-caudal direction;

wherein the actuation member comprises a first wedge member threadingly mated with a first threaded section of the actuation member that extends along a first central longitudinal axis and a second wedge member threadingly mated with a second threaded section of the actuation member that is joined with the first threaded section, the second threaded section extending along a second central longitudinal axis of the actuation member, wherein the first central longitudinal axis and the second central longitudinal axis form an angle between 15° and 75°, and

wherein the actuation member comprises a dual universal joint located between the first threaded section and the second threaded section, the dual universal joint comprising a central narrow, circular flange configured to couple with the inferior endplate and the superior endplate.

13. The method of claim 12, wherein:

the actuation member comprises 1) a distal end located proximate an insertion end portion of the intervertebral implant and proximate the second threaded section, and 2) a proximal end located proximate the first threaded section, and

rotating the first threaded section in a first rotational direction causes the second threaded section to rotate in the first rotational direction.

14. The method of claim 13, wherein the first threaded section is oppositely threaded from the second threaded section.

15. The method of claim 13, wherein rotating the first threaded section in the first rotational direction causes the first and second wedge members to move the inferior and superior endplates apart unevenly in the cranial-caudal direction so as cause one of lordotic and kyphotic expansion between the superior and inferior vertebral bodies.

DePuy Synthes Products, Inc.
Patent Attorneys for the Applicant/Nominated Person
SPRUSON & FERGUSON

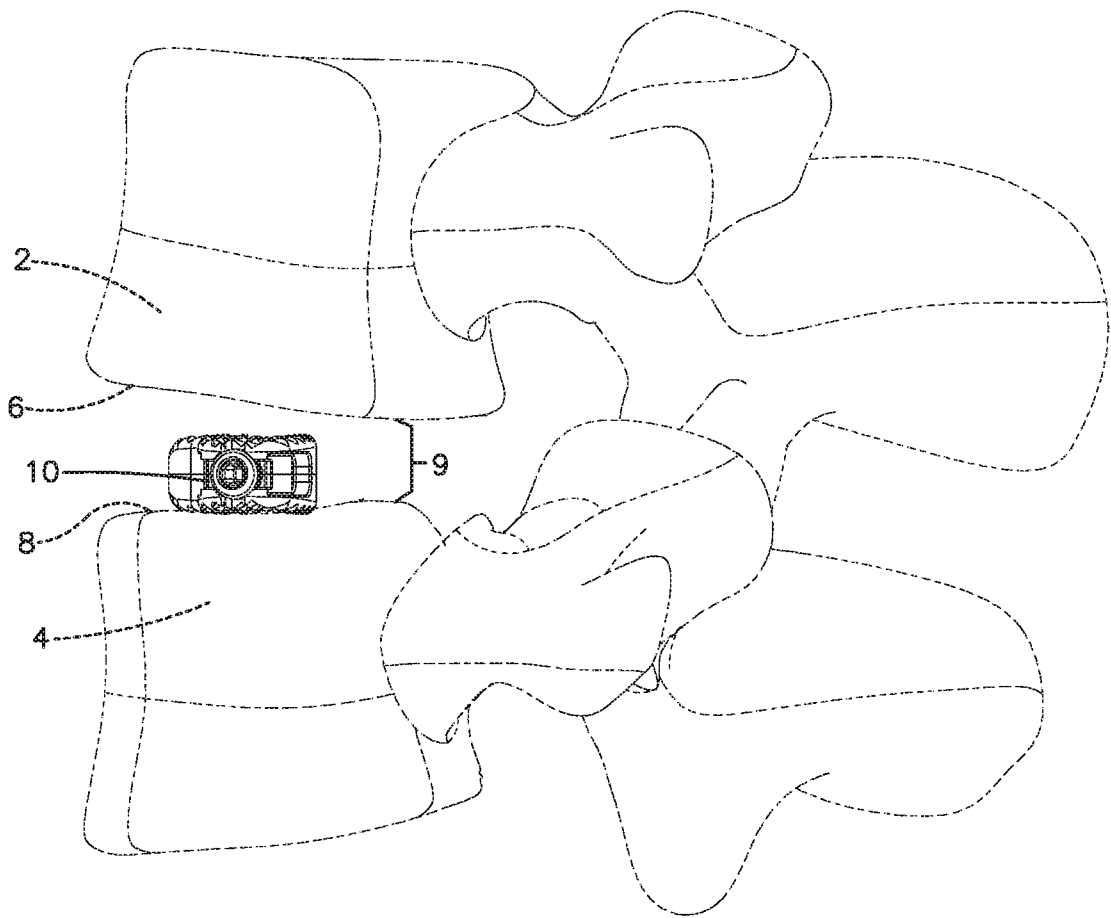
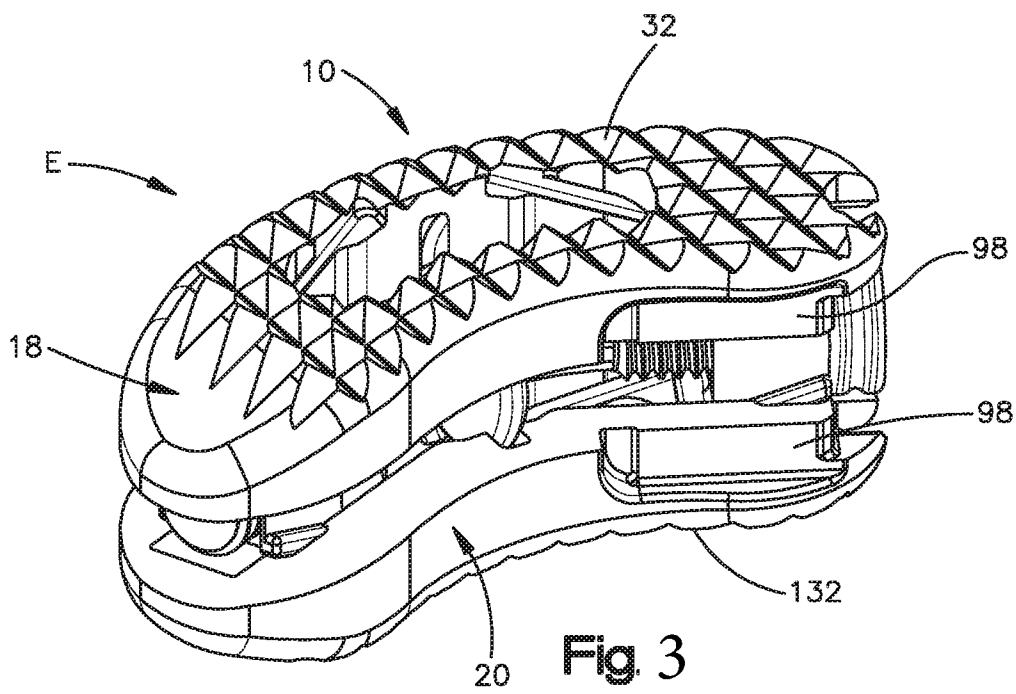
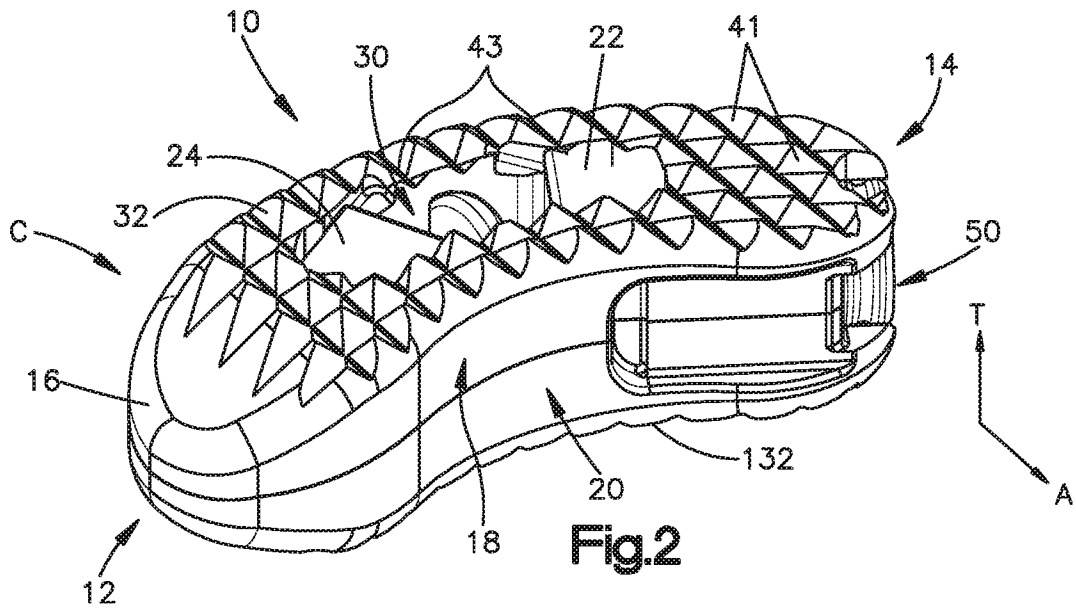

Fig.1



3/18

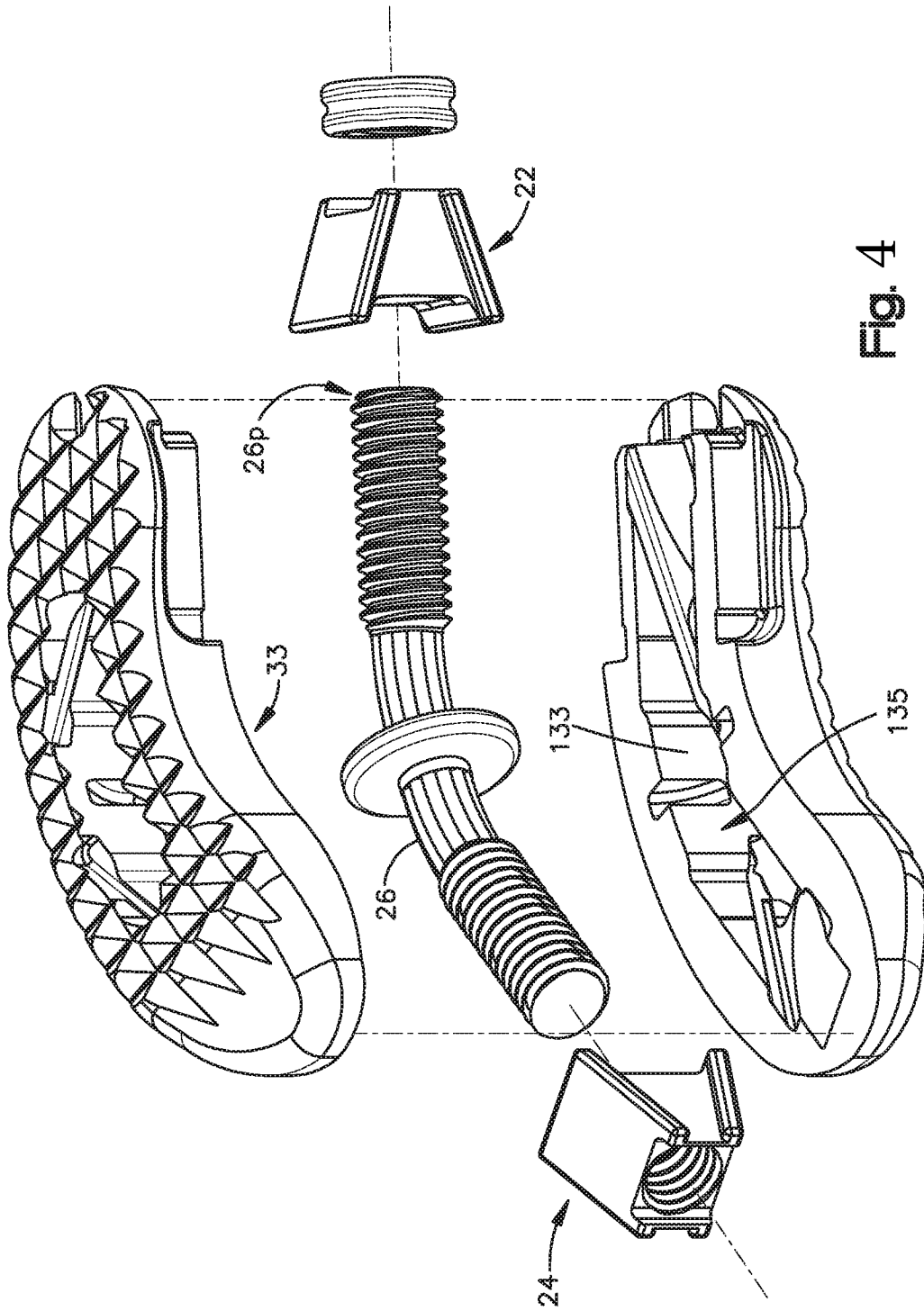

Fig. 4

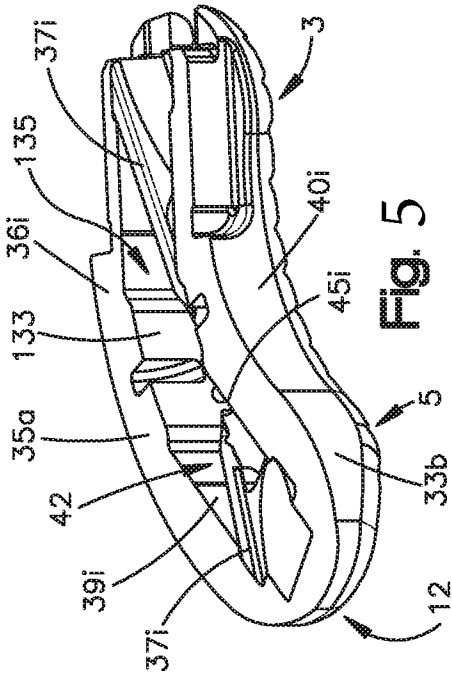

Fig. 5

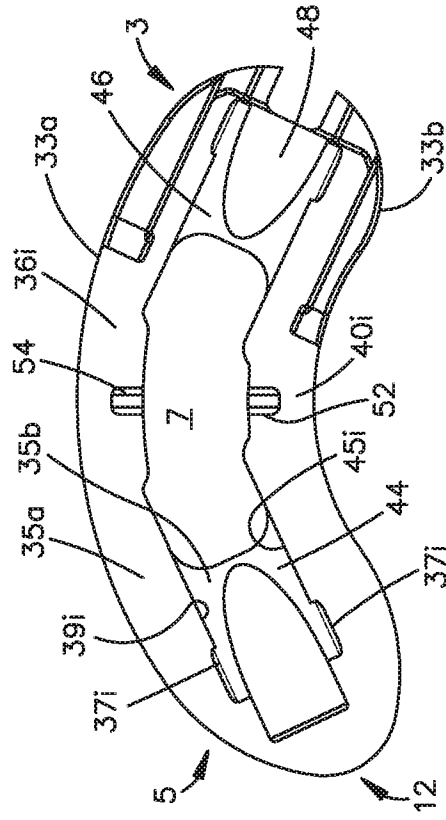

Fig. 7

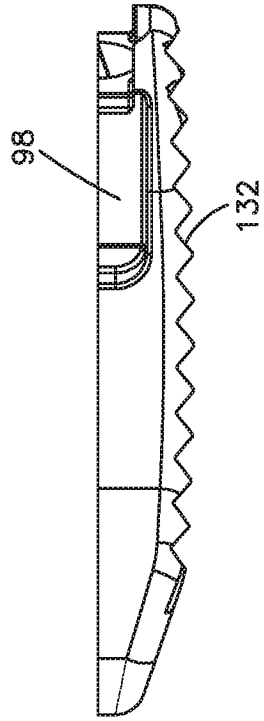

Fig. 6

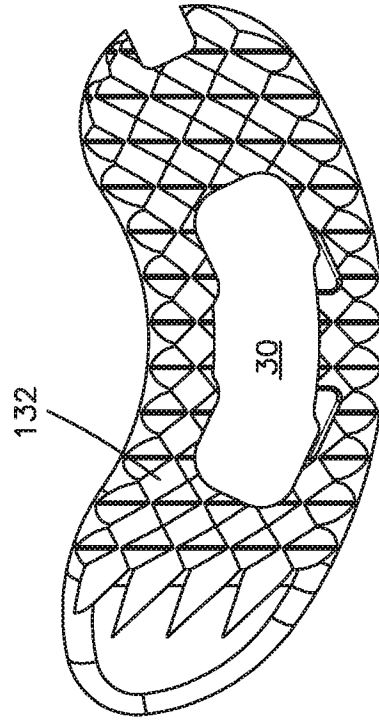

Fig. 8

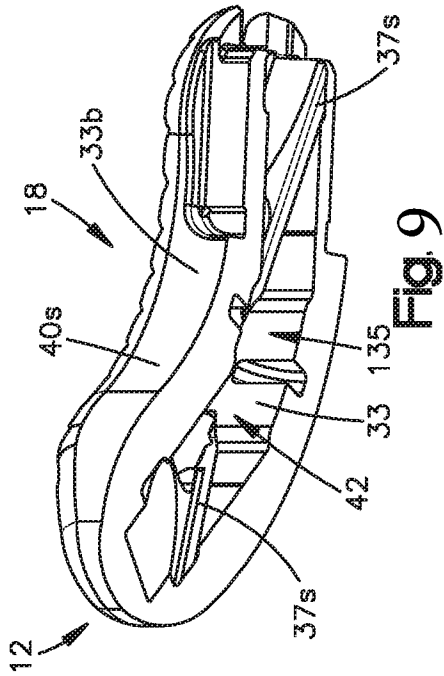

Fig. 10

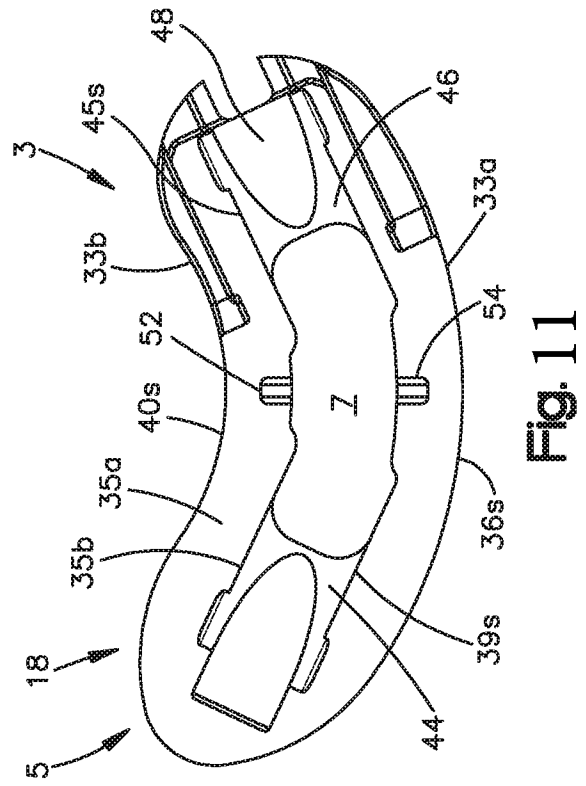
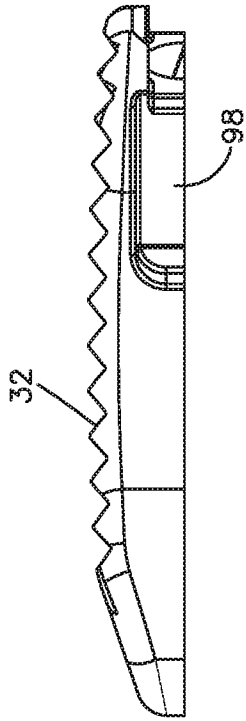
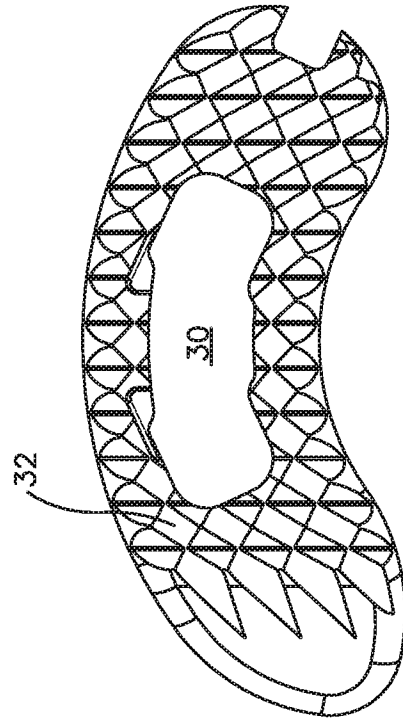

Fig. 12



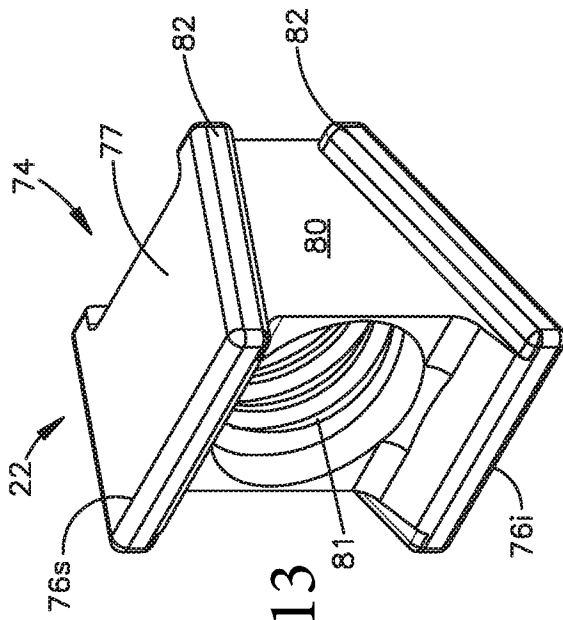

Fig. 13

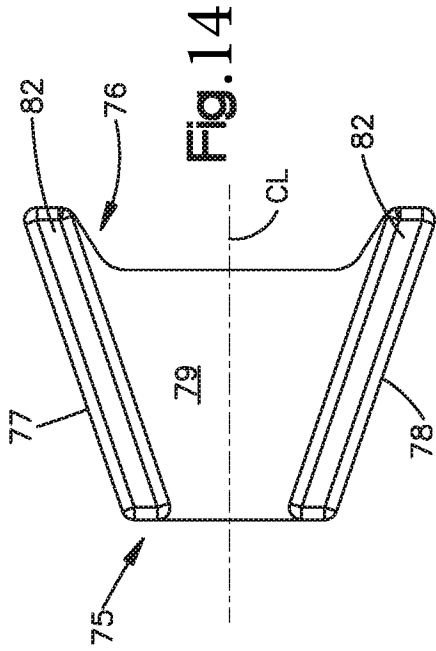

Fig. 14

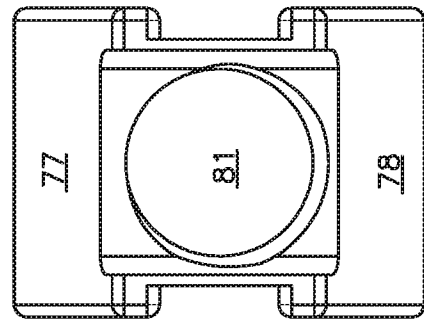

Fig. 15

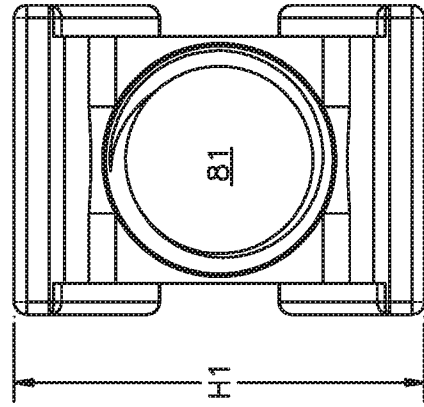
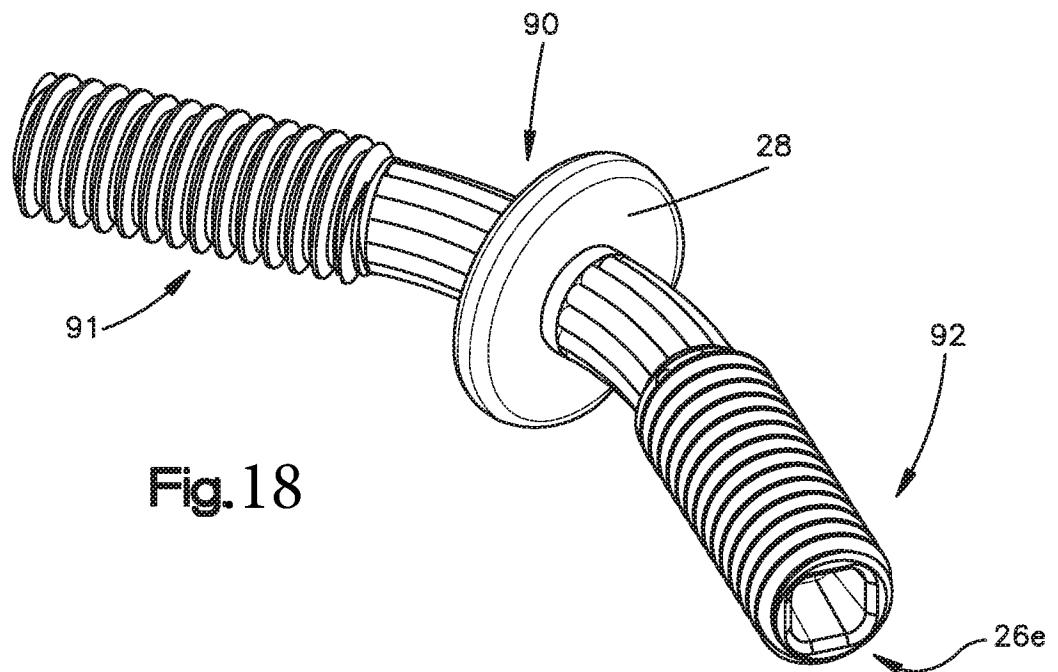
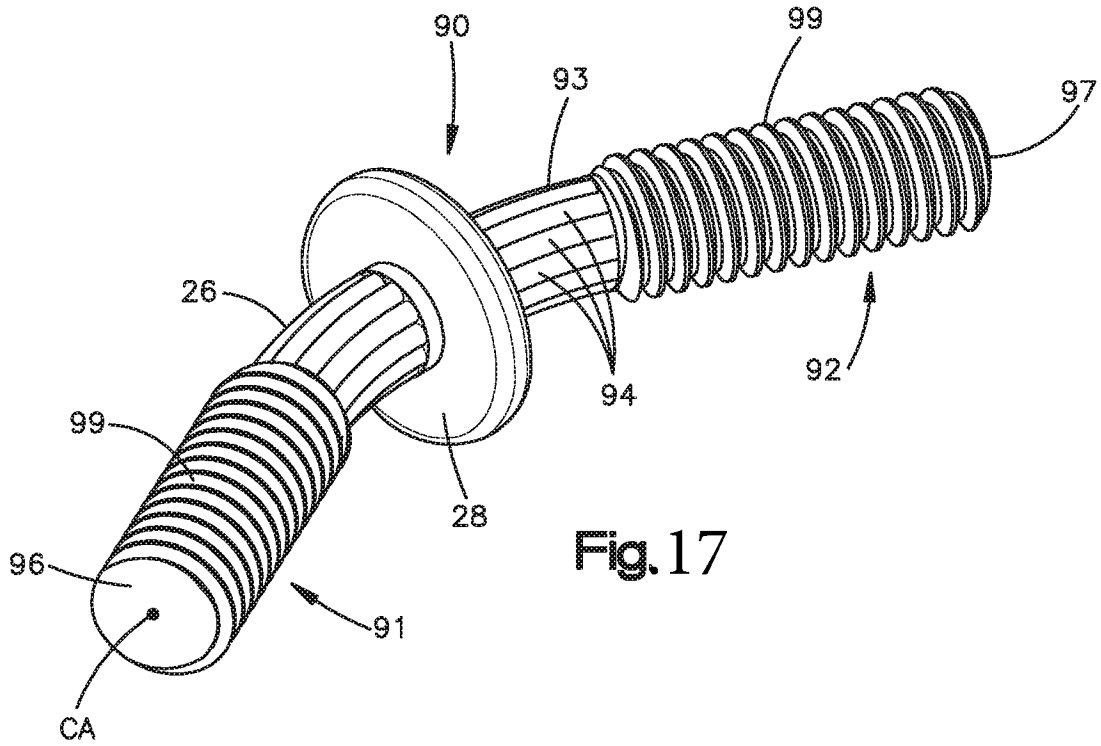

Fig. 16

7/18



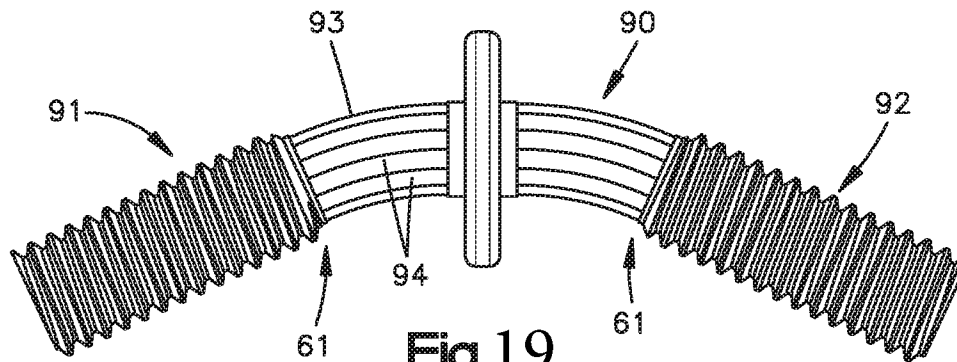

Fig. 19

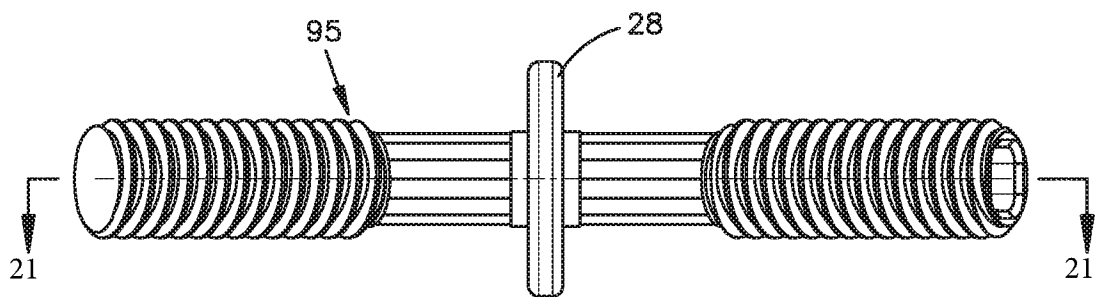

Fig. 20

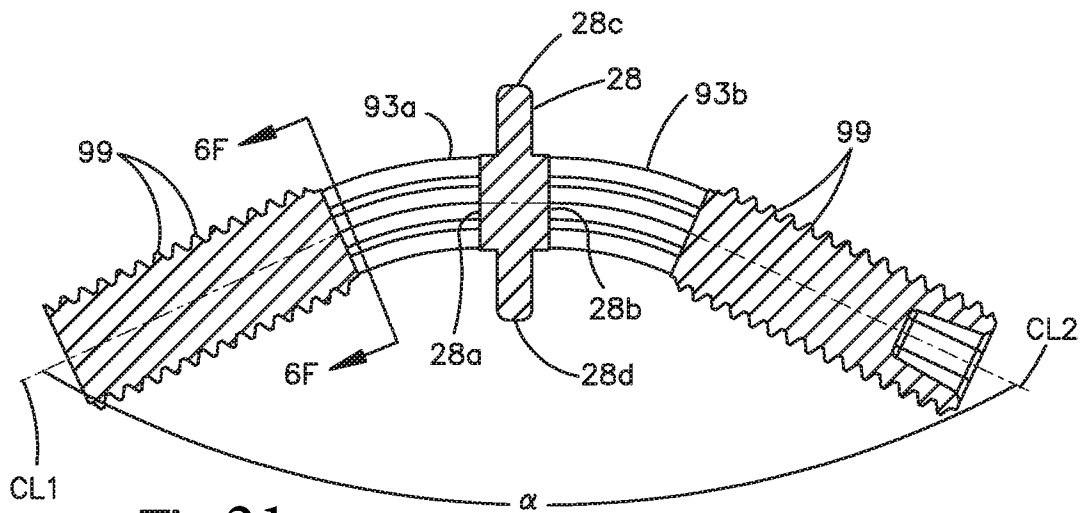

Fig. 21

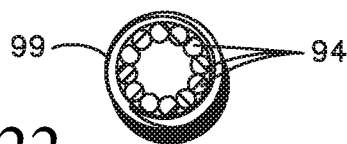
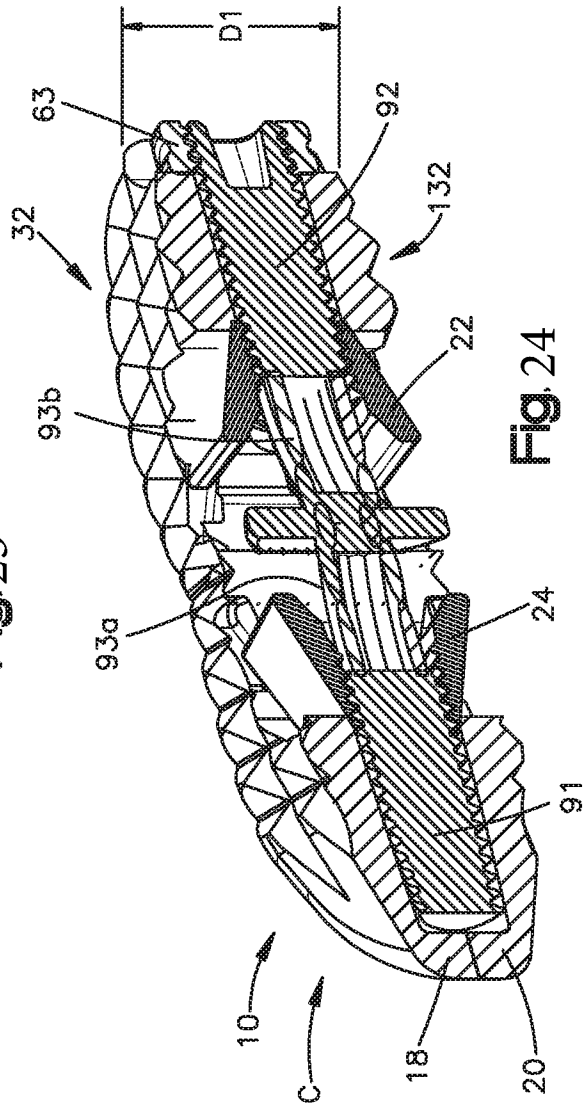
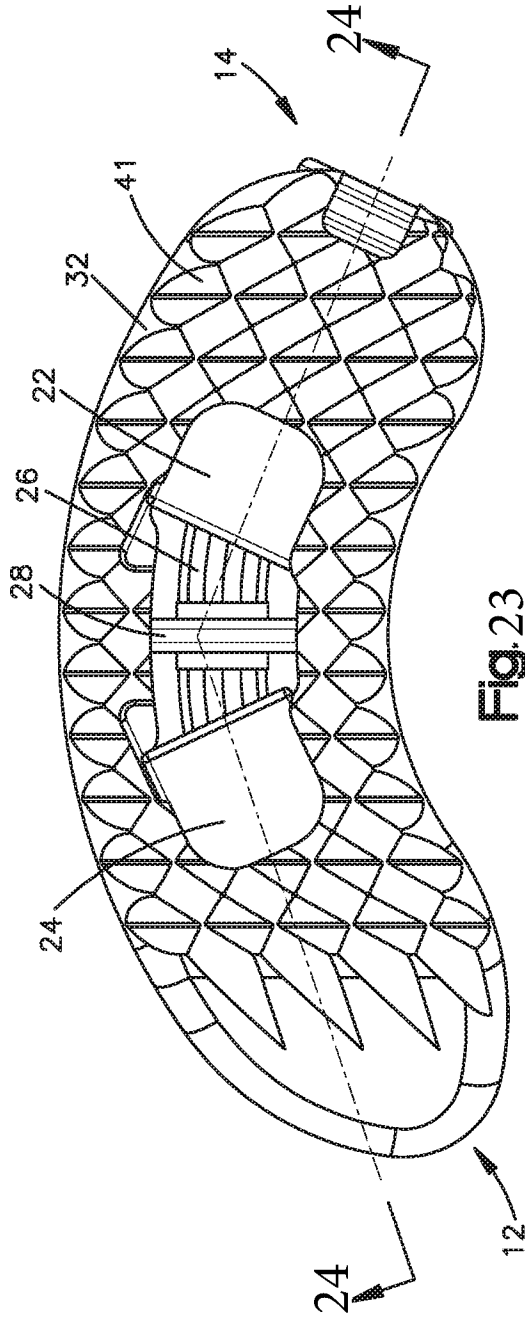

Fig. 22



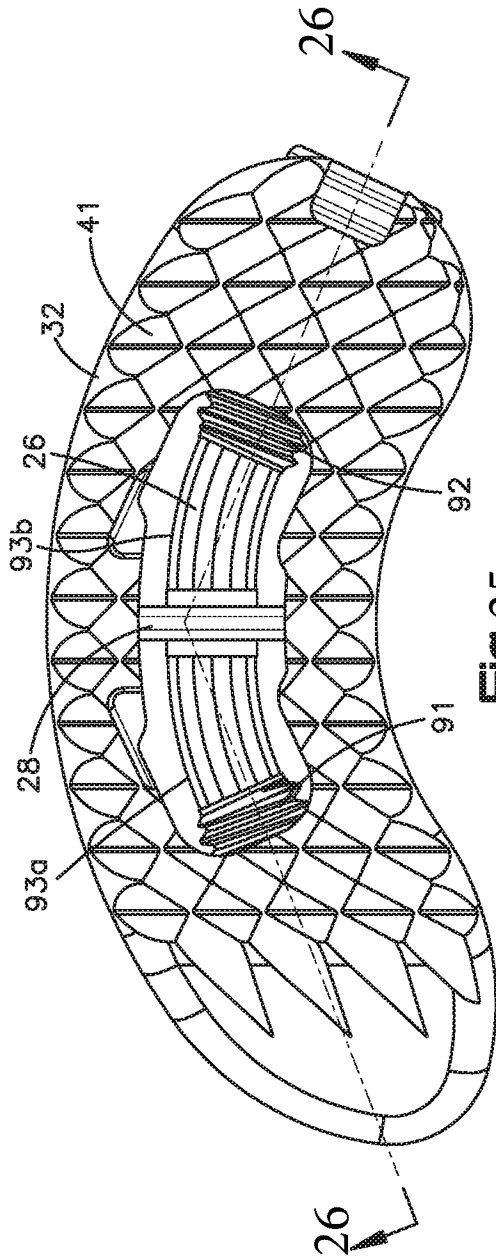

Fig. 25

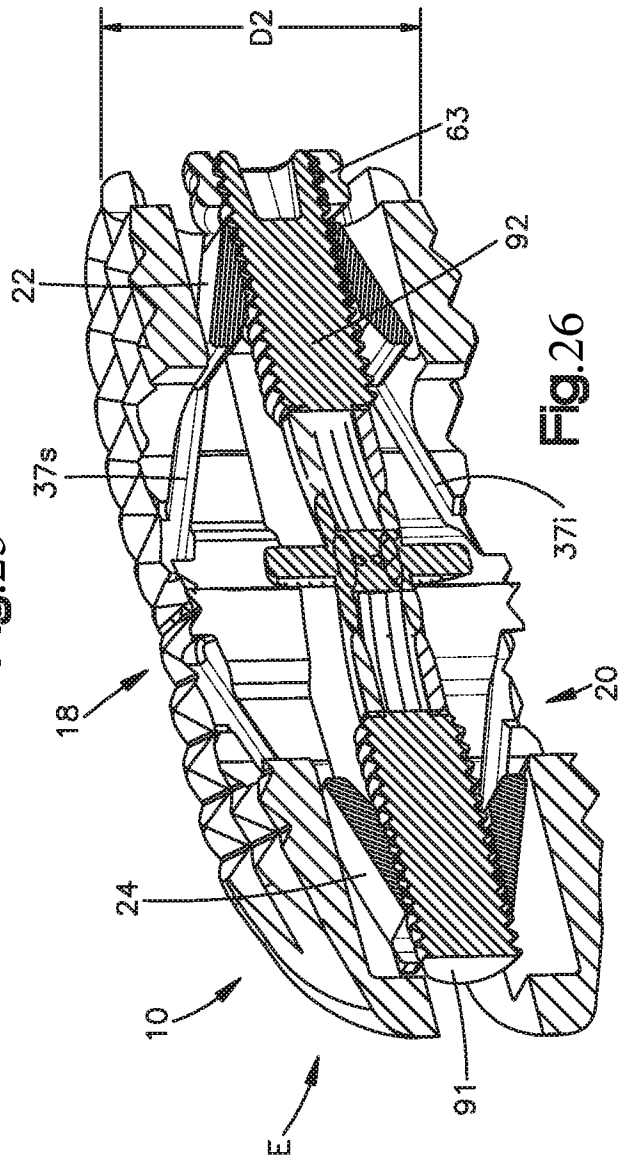
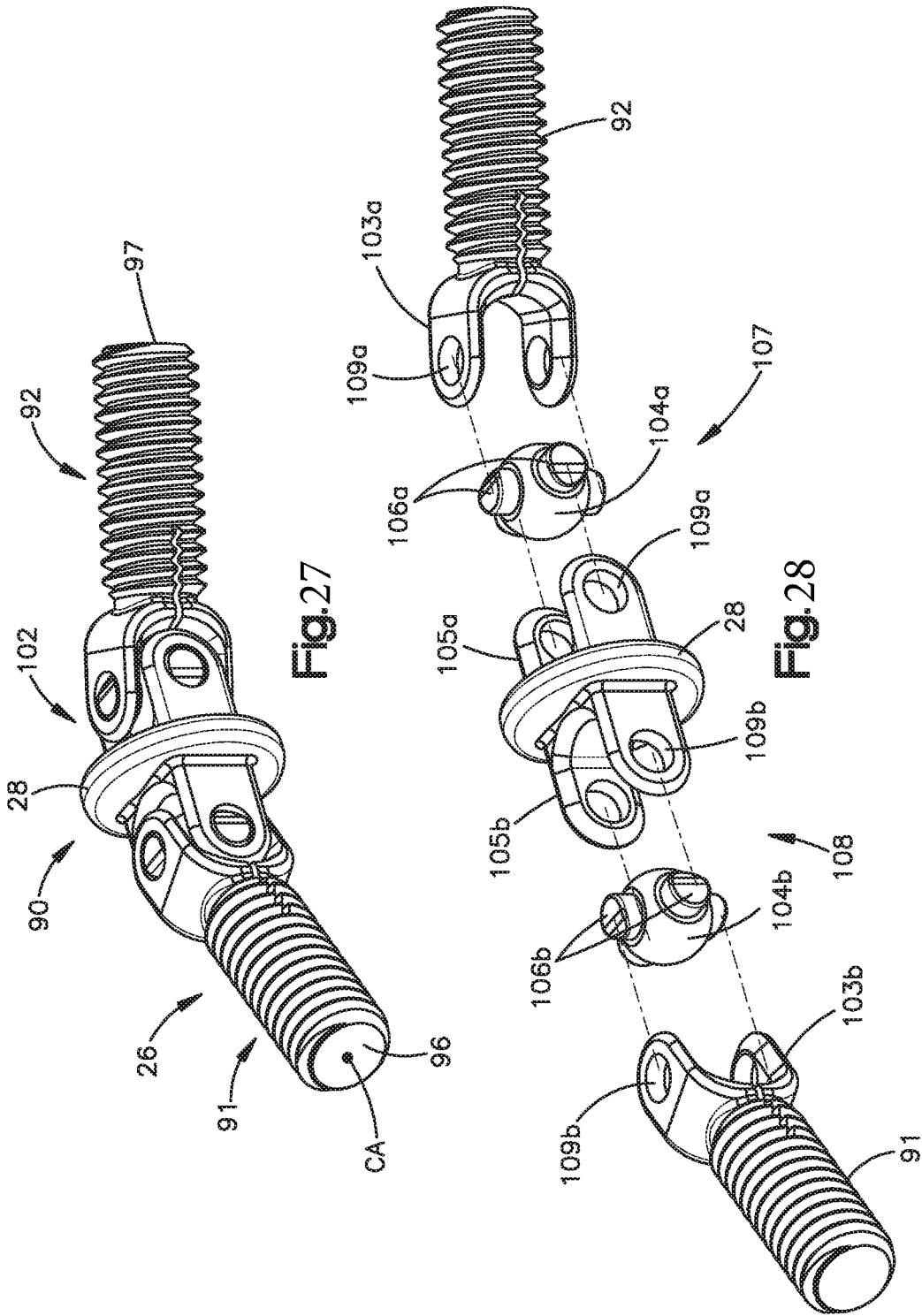

Fig. 26



12/18

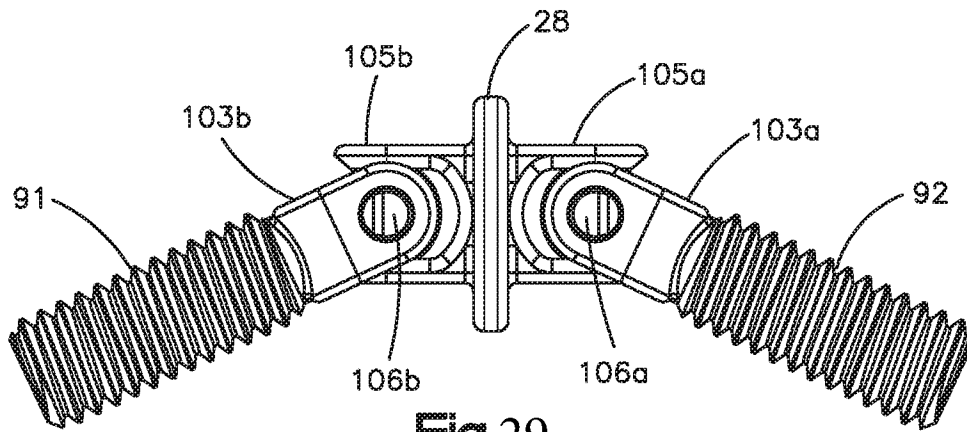

Fig.29

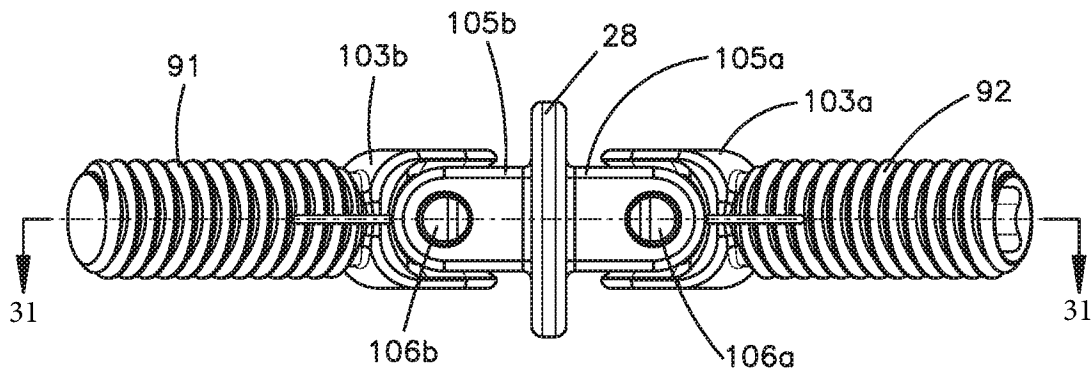

Fig.30

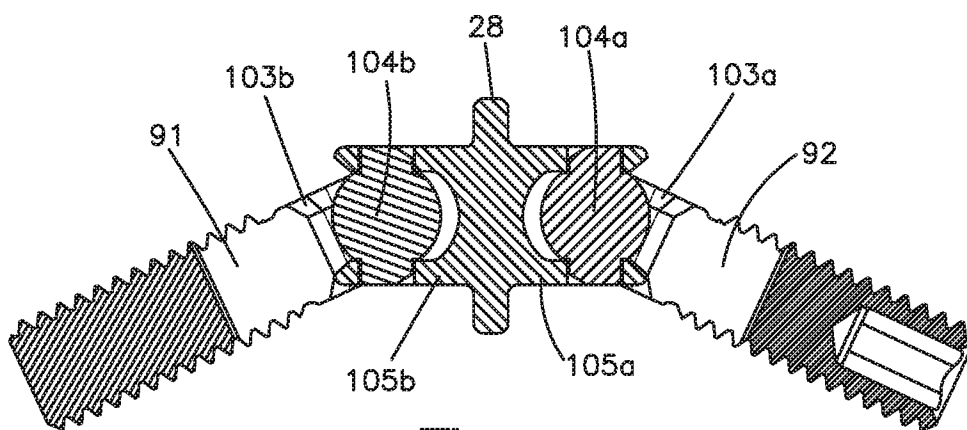

Fig.31

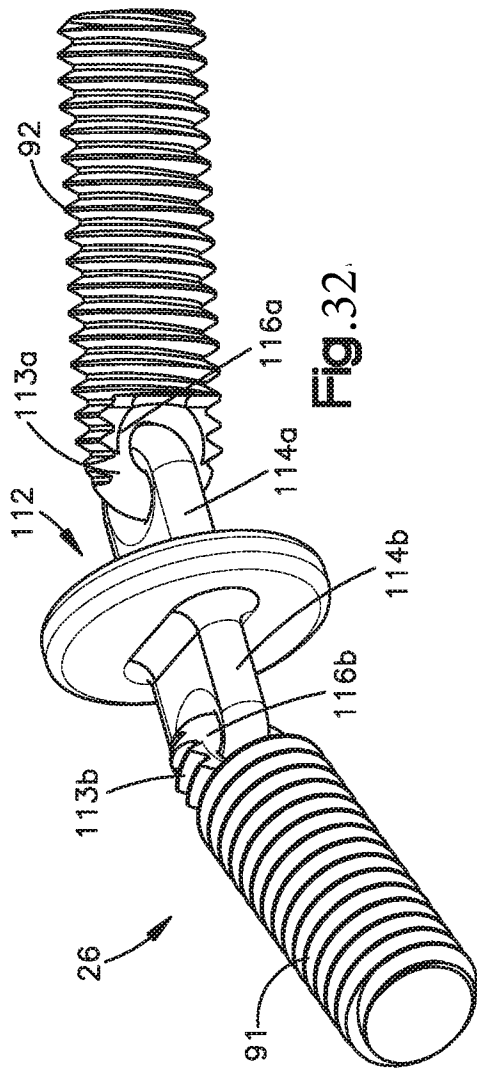

Fig. 32.

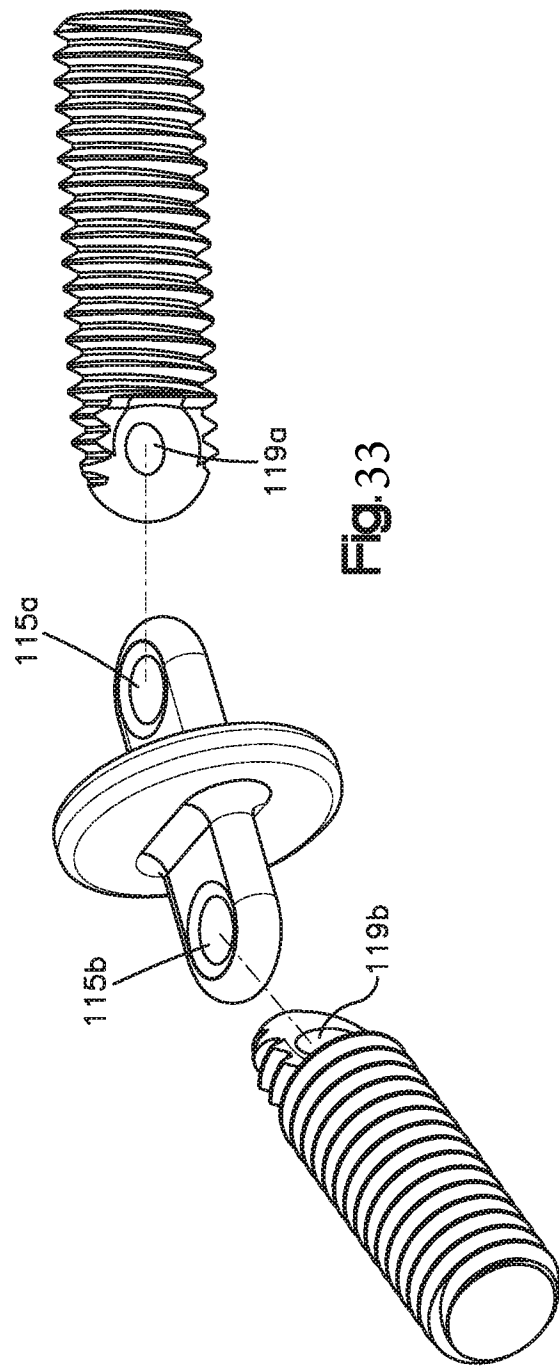

Fig. 33

14/18

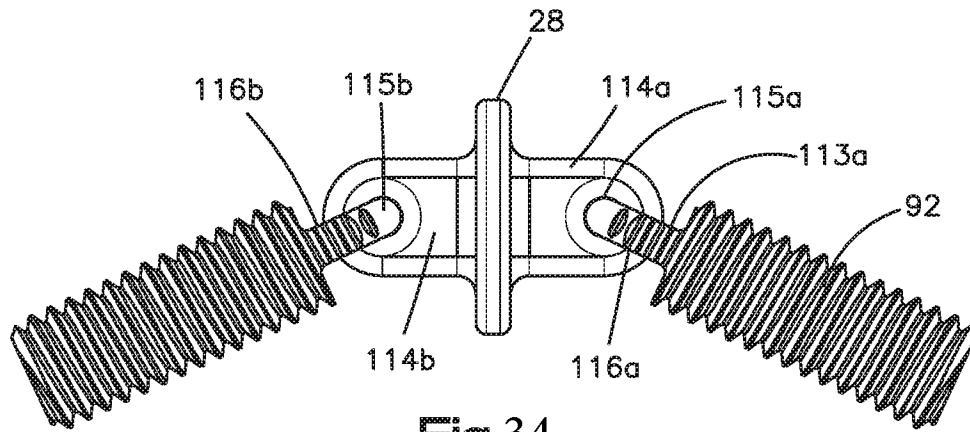

Fig.34

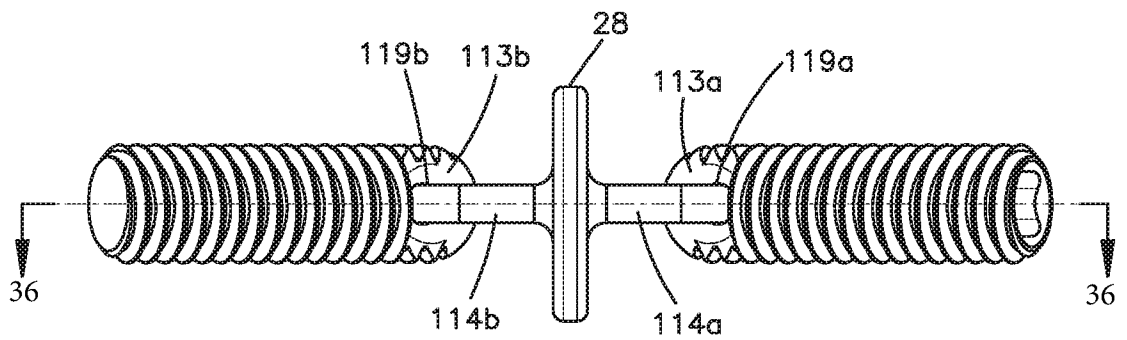

Fig.35

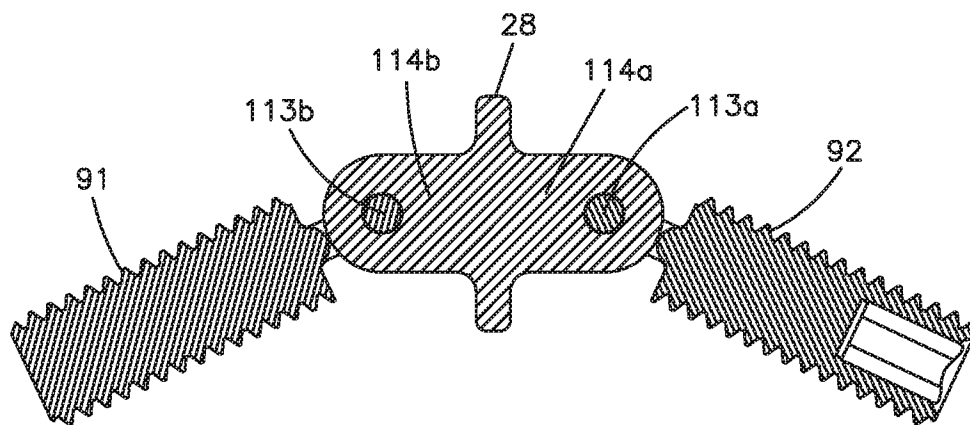

Fig.36

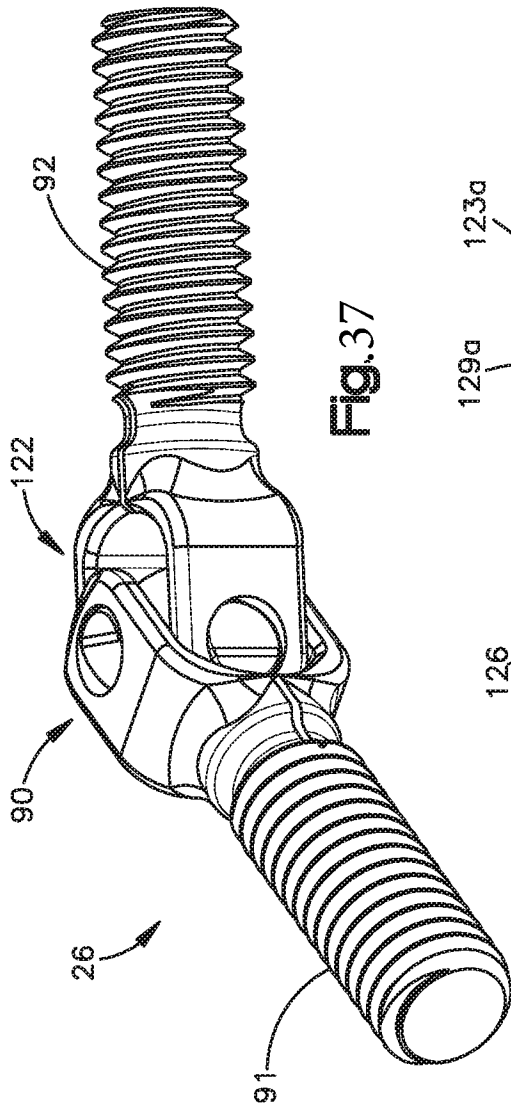

Fig. 37

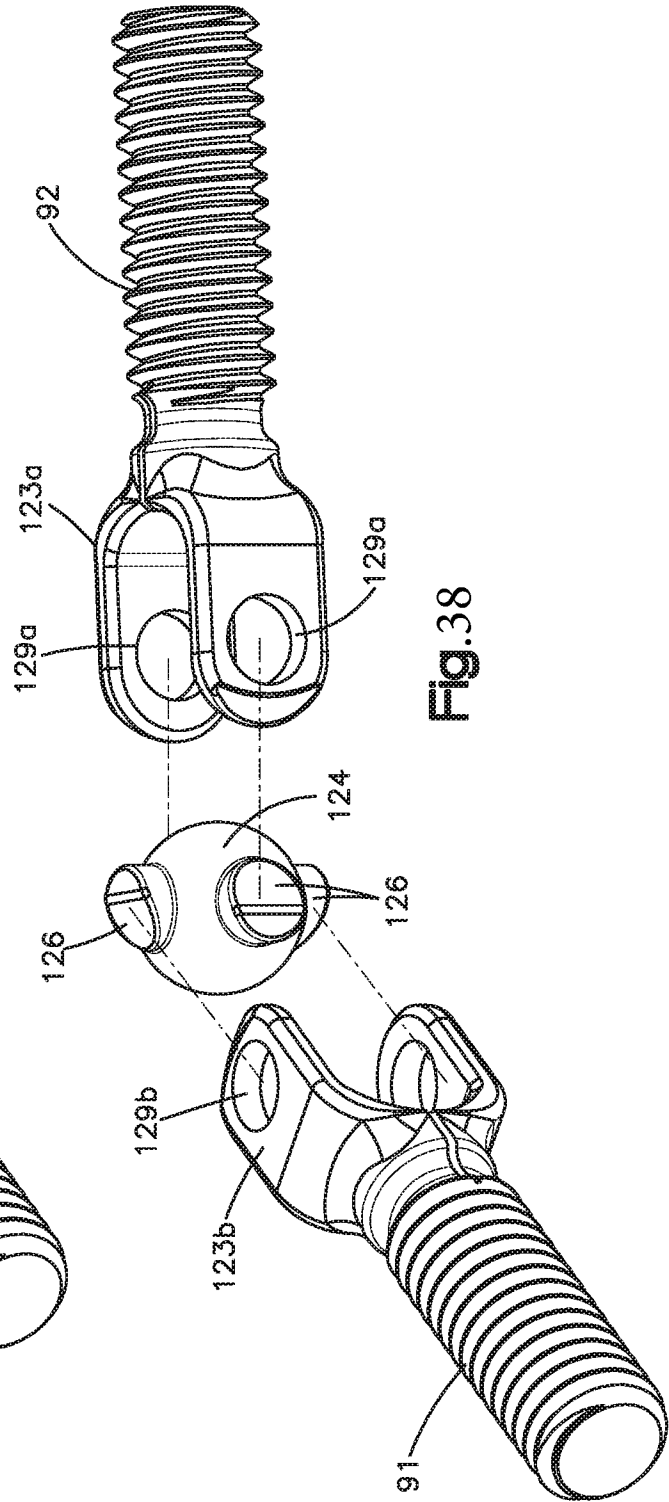

Fig. 38

16/18

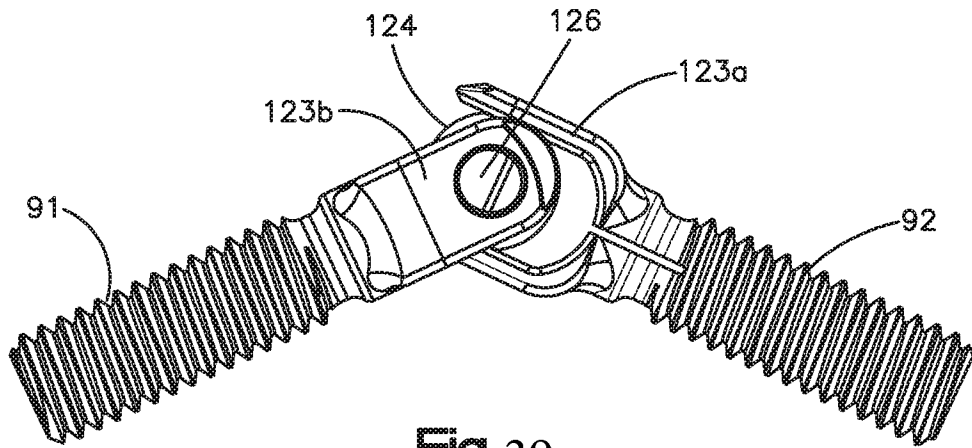

Fig. 39

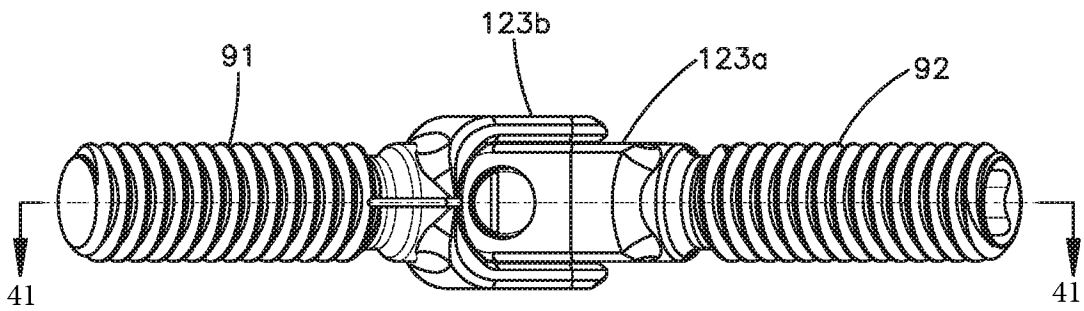

Fig. 40

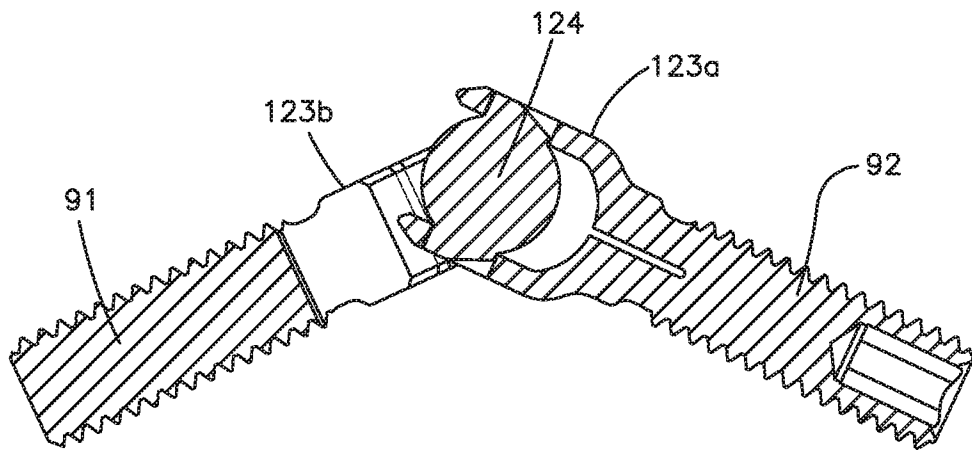
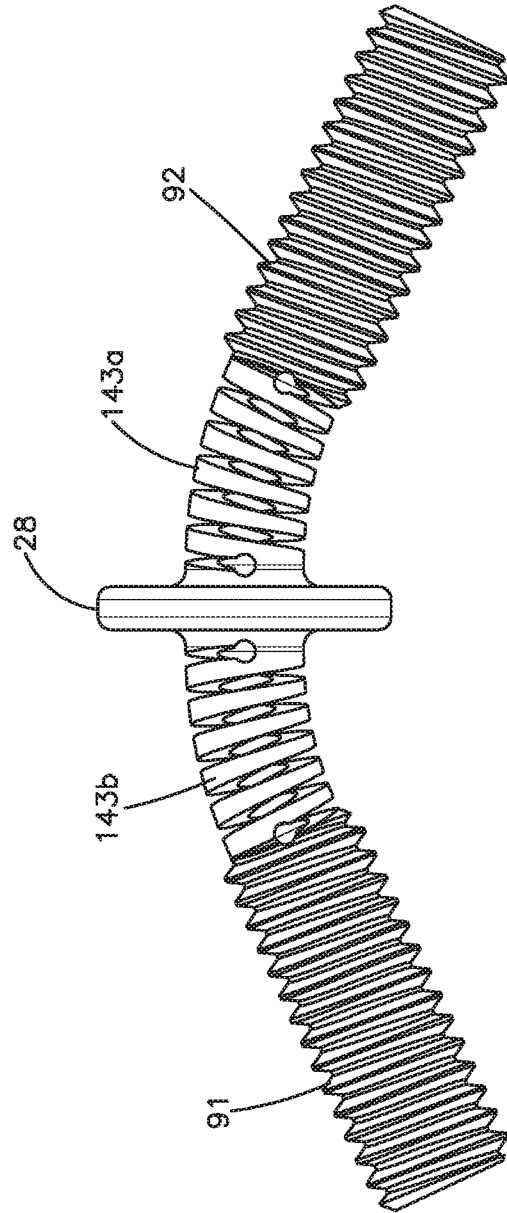
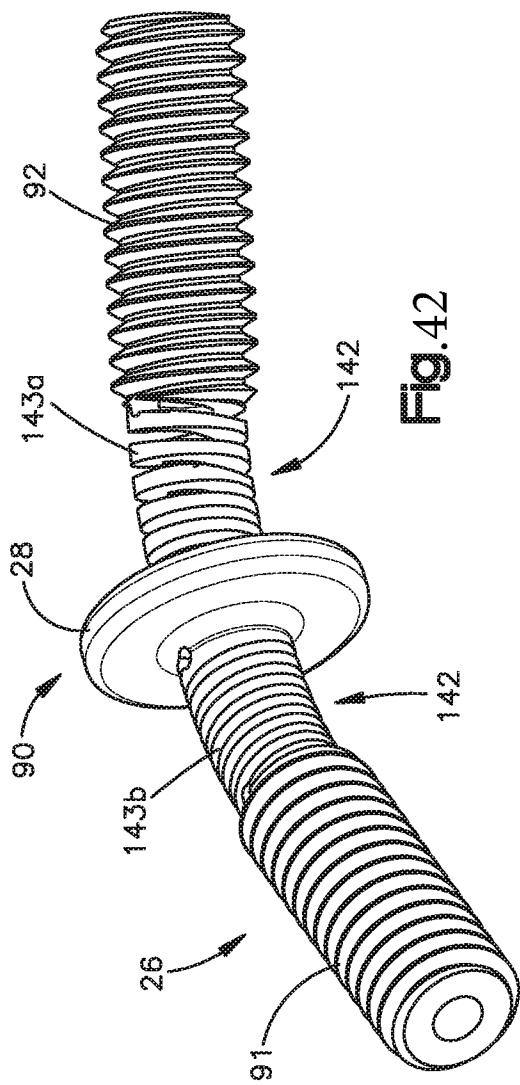

Fig. 41



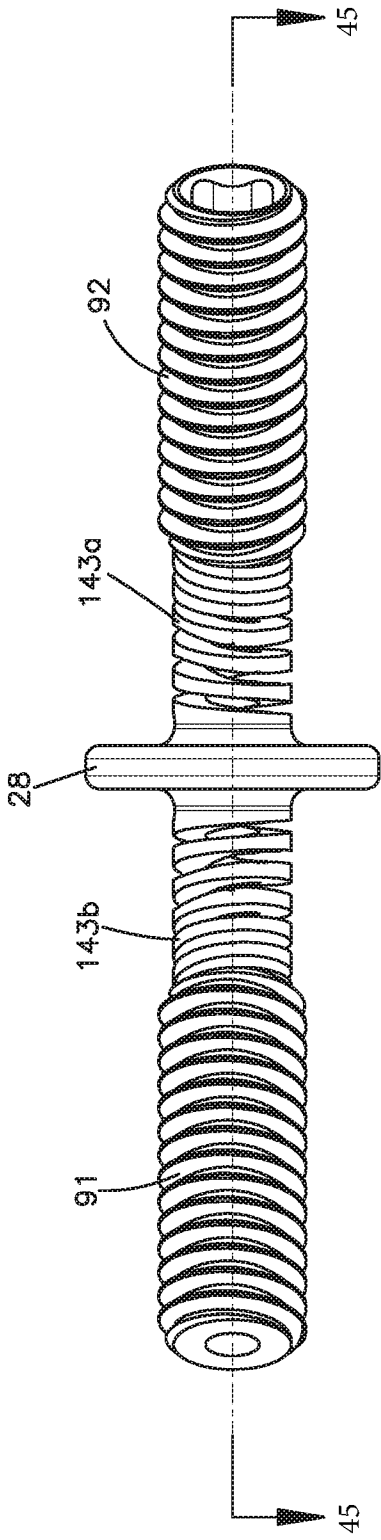

Fig. 44

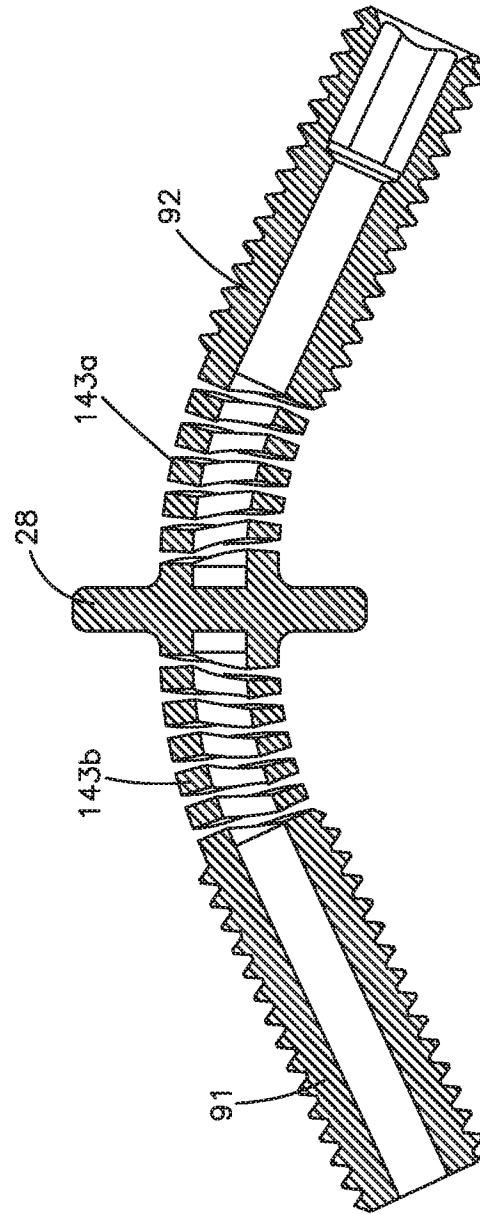

Fig. 45