

(No Model.)

J. E. HITCH.  
SAMPLE CASE.

No. 470,567.

Patented Mar. 8, 1892.

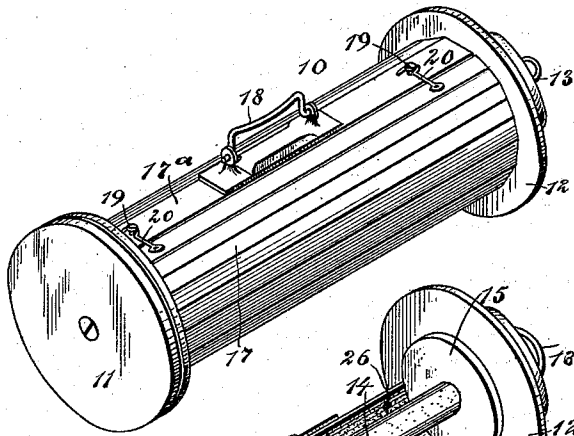

Fig 1

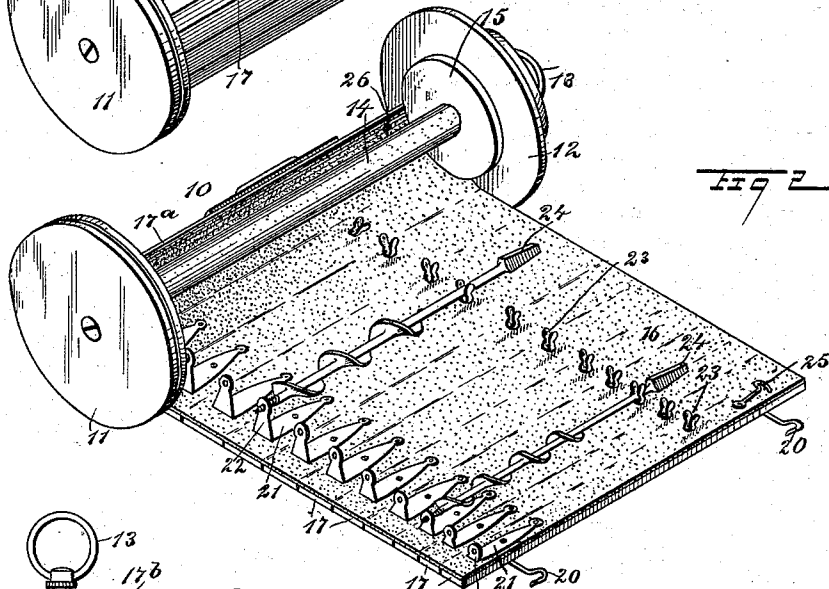

Fig 2

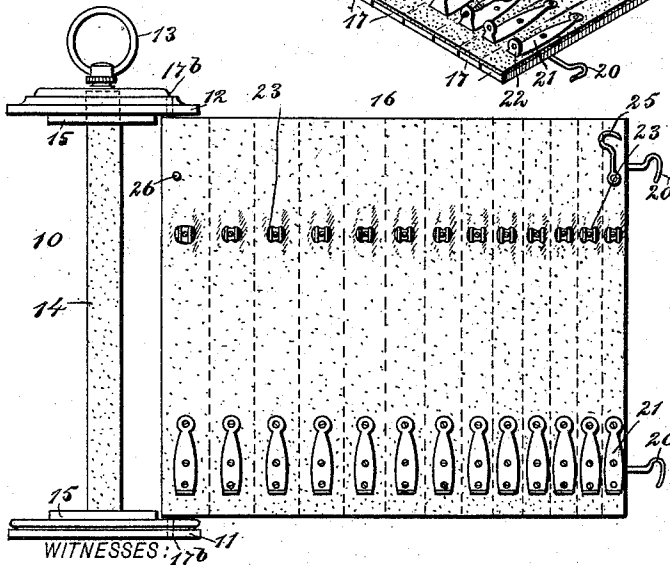

Fig 3

WITNESSES:  
H. Walker  
C. Sedgwick

INVENTOR:  
J. E. Hitch  
BY Munn & Co  
ATTORNEYS

# UNITED STATES PATENT OFFICE.

JOHN E. HITCH, OF WILMINGTON, OHIO.

## SAMPLE-CASE.

SPECIFICATION forming part of Letters Patent No. 470,567, dated March 8, 1892.

Application filed May 14, 1891. Serial No. 392,695. (No model.)

*To all whom it may concern:*

Be it known that I, JOHN E. HITCH, of Wilmington, in the county of Clinton and State of Ohio, have invented a new and Improved Sample-Case, of which the following is a full, clear, and exact description.

My invention relates to improvements in sample-cases; and the object is to produce a sample-case which is especially adapted to exhibit auger-bits, cutlery, jewelry, and various articles of hardware, which is adapted to hold said articles in a very small compass, and which is arranged so as to exhibit the goods to great advantage.

To this end my invention consists in a sample-case constructed substantially as hereinafter described and claimed.

Reference is to be had to the accompanying drawings, forming a part of this specification, in which similar figures of reference indicate corresponding parts in all the views.

Figure 1 is a perspective view of the closed case. Fig. 2 is a perspective view of the case when partially opened and showing auger-bits in position within it, and Fig. 3 is a plan view of the case when thrown entirely open.

The case 10 is provided with end pieces 11 and 12, which are preferably circular in form, but which may be made of any shape, and the inner portions of which are flat. The end piece 11 forms the base of the case and is flat on both sides; but the outer side of the end piece 12 is preferably rounded up and ornamented in some way and is provided centrally with a ring 13, by means of which the case may be suspended. The end pieces are connected by a center rod 14, which is firmly secured to each, and on the center of each of the end pieces and on the inner sides of the same are blocks 15, which are preferably annular, but which are made to conform to the circumferential shape of the end pieces, and these blocks 15 form shoulders for the flexible wall of the case. The blocks are preferably formed of the same material as the end pieces.

The flexible wall 16 is formed of a series of narrow slats 17, which are flexibly united in any convenient way, and the length of the slats is such that they will close nicely between the end pieces 11 and 12 and will bear at the ends upon the shoulder-blocks 15. The

inner portions of the flexible wall, as well as the center rod 14, are preferably lined with plush or some similar ornamental material. At one end of the flexible wall 16 is a slat 17<sup>a</sup>, which is wider than the others, and this slat is pivoted to the end pieces 11 and 12 by means of pins 17<sup>b</sup>, (shown in dotted lines in Fig. 3,) which pins are secured to the slat and enter holes in the end pieces. This slat is also provided centrally with a handle 18, by means of which the case may be conveniently carried about. The slat 17<sup>a</sup> is also provided near the ends and on the outer side with projecting studs 19, which serve to engage the hooks 20, which hooks are pivoted to the outer end slat of the flexible wall, and it will be seen that when the wall is rolled up within the end pieces the hooks 20 and studs 19 will serve to hold it in place. It is obvious, however, that other forms of catches may be used without departing from the principle of my invention.

The interior of the flexible wall is provided with supports, which in the drawings are adapted to hold auger-bits, but which may be made in conformity with the articles which they are to hold. For bits one side of the wall is provided with a series of brackets 21, which are secured thereto and which have laterally-extending flanges 22, which flanges are perforated near their outer ends, as shown, so as to receive the screw-points of auger-bits. Near the opposite side of the flexible wall are a series of spring-catches 23, which are adapted to fit the shanks of the bits 24, and these catches consist of parallel spring-fingers, which converge near the center and diverge at their outer ends, so that they will spring around the shank of a bit when it is forced between the fingers; but it is obvious that any suitable catch may be substituted for those shown.

To insert the bits, the points are preferably screwed slightly in the perforations of the brackets 21 and their shanks are dropped into the spring-catches 23. It will thus be seen that when the bits or other articles are secured to the flexible wall and the wall is rolled up and fastened the articles will be held in a very small compass and may be conveniently carried about, and when the goods are to be exhibited the wall is rolled out flat, as in Fig. 3, and the goods will thus be displayed to great

advantage and without the necessity of handling them.

If desired, the flexible wall may be turned inside out, so that the articles held by the case may be exhibited advantageously, and to this end the wall is provided with a catch 25 on the inside and near one edge and with a stud 26 near the opposite edge, so that by hooking the catch upon the stud the wall may 10 be held in position. The center rod 14 may be provided with supporting-catches, to which various articles may be secured, thus increasing the capacity of the case.

Having thus described my invention, I 15 claim as new and desire to secure by Letters Patent—

1. A sample-case comprising end pieces having interior shoulders, a flexible wall pivoted between the end pieces and adapted to be 20 rolled upon the shoulders, and supports secured on the wall, substantially as described.

2. A sample-case comprising connected end pieces having interior shoulders, a flexible wall pivoted between the end pieces and 25 adapted to be rolled upon the shoulders, supports on the interior of the wall, and catches to fasten the wall in a closed position, substantially as described.

3. A sample-case comprising connected end

pieces having interior shoulders thereon and a 30 flexible wall pivoted between the end pieces and adapted to be rolled upon the shoulders, the said wall having on its interior surface a series of catches and having its exterior surface provided with catches to hold it in a 35 closed position and with a suitable handle, substantially as described.

4. A sample-case comprising connected end pieces having interior shoulders, a flexible wall pivoted between the end pieces and 40 adapted to be rolled upon the shoulders, catches to hold the wall in a closed position, a series of brackets secured on the interior of the wall and near one edge, said brackets having projecting perforated flanges, and a series 45 of spring-catches aligning with the brackets secured to the wall near the opposite edge of the same, substantially as described.

5. A sample-case comprising a cross-piece, stationary end pieces fixedly and permanently 50 secured at their inner faces to the ends of the cross-piece, and a flexible wall pivotally connected at its inner end with the end pieces and having supports, substantially as set forth.

JOHN E. HITCH.

Witnesses:

C. M. JENKINS,  
C. H. IRWIN.