



US00D716574S

(12) **United States Design Patent**
Akkad

(10) **Patent No.:** **US D716,574 S**

(45) **Date of Patent:** **** Nov. 4, 2014**

(54) **WEBBED SAUCER CHAIR WITH CENTRAL PAD**

(71) Applicant: **Idea Nuova, Inc.**, New York, NY (US)

(72) Inventor: **Benjamin S. Akkad**, New York, NY (US)

(73) Assignee: **Idea Nuova, Inc.**, New York, NY (US)

(**) Term: **14 Years**

(21) Appl. No.: **29/483,471**

(22) Filed: **Feb. 28, 2014**

(51) **LOC (10) Cl.** **06-01**

(52) **U.S. Cl.**
USPC **D6/368**

(58) **Field of Classification Search**

USPC D6/334-336, 348-349, 363, 366-369,
D6/371-376, 379, 716, 716.1-716.4;
273/396; 297/16.1, 16.2, 31, 34,
297/45-47, 50, 56, 271.6, 314, 411.41,
297/440.11, 440.24, 448.1, 451.4, 452.12,
297/452.13; 473/197, 431, 456

See application file for complete search history.

(56) **References Cited**

U.S. PATENT DOCUMENTS

244,216 A	7/1881	Fenby
398,943 A	3/1889	Crandall
615,476 A	12/1898	Chapman
1,027,692 A	5/1912	Cole
1,185,568 A	5/1916	Zeunert
1,263,717 A	4/1918	Stone
1,443,734 A	1/1923	Clyde
1,939,743 A	12/1933	Warner
1,942,112 A	1/1934	McQuilkin

(Continued)

FOREIGN PATENT DOCUMENTS

CN	87201431 U	2/1988
CN	2103938 U	5/1992

(Continued)

OTHER PUBLICATIONS

Office Action Issued Oct. 18, 2010 in U.S. Appl. No. 12/544,256.

(Continued)

Primary Examiner — Ricky Pham

(74) *Attorney, Agent, or Firm* — Panitch Schwarze Belisario & Nadel LLP

(57) **CLAIM**

The ornamental design for a webbed saucer chair with central pad, as shown and described.

DESCRIPTION

FIG. 1 is a front perspective view of a webbed saucer chair with central pad in accordance with a first preferred embodiment of my new design;

FIG. 2 is a front elevation view thereof;

FIG. 3 is a left side elevation view thereof, a right side elevation view thereof being a mirror image;

FIG. 4 is a rear elevation view thereof;

FIG. 5 is a top plan view thereof;

FIG. 6 is a bottom plan view thereof;

FIG. 7 is a front perspective view of a webbed saucer chair with central pad in accordance with a second preferred embodiment of my new design;

FIG. 8 is a front elevation view thereof;

FIG. 9 is a left side elevation view thereof, a right side elevation view thereof being a mirror image;

FIG. 10 is a rear elevation view thereof;

FIG. 11 is a top plan view thereof; and,

FIG. 12 is a bottom plan view thereof.

The broken lines in the figures are for the purpose of showing environmental structure and form no part of the claimed design.

1 Claim, 10 Drawing Sheets

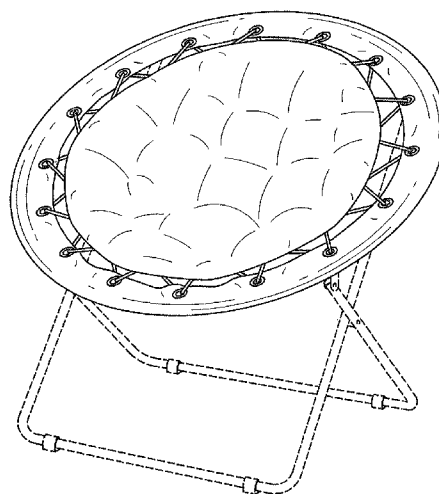
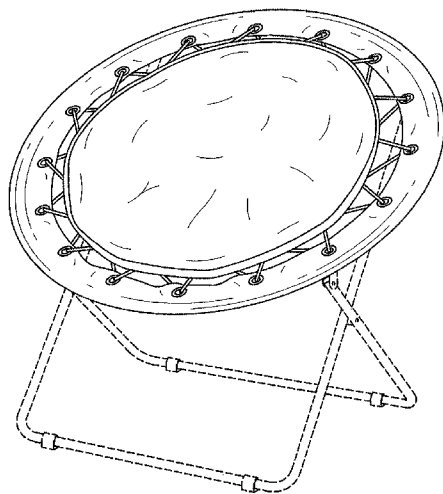

(56)

References Cited

U.S. PATENT DOCUMENTS

2,381,574 A	8/1945	Clarín	5,979,976 A	11/1999	Ferencik
2,473,090 A	6/1949	Becker	5,984,406 A	11/1999	Lee
2,587,543 A	2/1952	Smith	6,045,177 A	4/2000	Grace
2,590,049 A	3/1952	Sidlinger	6,056,354 A	5/2000	Tseng
D168,212 S *	11/1952	Cicchelli D6/379	6,082,813 A	7/2000	Chen
2,649,901 A	8/1953	Johnson	6,095,607 A	8/2000	Wenzel
D171,176 S	12/1953	Yellen	6,112,757 A	9/2000	Tseng
D171,265 S *	1/1954	Phillips D6/375	D431,382 S	10/2000	Eloge et al.
2,684,709 A *	7/1954	Schawinsky 297/411.41	D432,325 S	10/2000	Zheng et al.
2,691,410 A	10/1954	Boucher	D432,823 S	10/2000	Zheng
2,712,349 A	7/1955	LeVoir	D433,244 S	11/2000	Zheng
2,713,890 A	7/1955	Mack	D433,574 S	11/2000	Zheng
2,723,712 A *	11/1955	Yellen 297/440.11	6,149,238 A	11/2000	Tsai
2,733,755 A	2/1956	Boucher	6,179,374 B1	1/2001	Tang
2,763,318 A	9/1956	Bertoia	6,209,951 B1	4/2001	Han
D179,376 S *	12/1956	Breed D6/366	6,231,119 B1	5/2001	Zheng
D180,210 S	4/1957	Uretsky	6,237,993 B1	5/2001	Zheng
D184,202 S *	12/1958	Yuen D6/369	6,238,001 B1	5/2001	Yoran
2,902,084 A	9/1959	Stevens	6,241,311 B1	6/2001	Zheng
2,916,744 A	12/1959	May	6,247,748 B1	6/2001	Zheng
2,930,430 A *	3/1960	Bloom 297/271.6	6,264,271 B1	7/2001	Munn et al.
3,123,396 A	3/1964	Searle	6,283,046 B1	9/2001	Tseng
3,124,387 A	3/1964	MacLaren	6,296,304 B1	10/2001	Zheng
3,136,272 A	6/1964	Sprigman	6,302,479 B1	10/2001	Zheng
3,180,685 A *	4/1965	Rogalski et al. 297/440.24	6,312,343 B1	11/2001	Cho
3,635,520 A	1/1972	Roher et al.	6,322,138 B1	11/2001	Tang
3,656,808 A *	4/1972	Chang 297/451.4	6,332,646 B1	12/2001	Tseng
3,694,030 A *	9/1972	Grosfillex 297/448.1	6,354,657 B1	3/2002	Nelson et al.
3,767,192 A	10/1973	Eriksson	6,364,411 B1	4/2002	Zheng
3,838,883 A	10/1974	Machen	6,371,553 B1	4/2002	Tang
3,941,416 A	3/1976	Uchida	D456,628 S	5/2002	Satoshi
4,045,045 A	8/1977	Boucher et al.	6,382,715 B1	5/2002	Tang
4,047,752 A	9/1977	Rohr	6,382,729 B1	5/2002	Wu
4,105,244 A	8/1978	Colby	6,402,230 B1	6/2002	Tang
4,118,065 A	10/1978	Watkins	D460,280 S	7/2002	Fox
4,193,630 A	3/1980	Steele	6,419,311 B1	7/2002	Tang
4,231,582 A	11/1980	Moss	6,447,057 B1	9/2002	Chen
4,258,951 A	3/1981	Groom	6,454,348 B1	9/2002	Wu
4,290,643 A	9/1981	Logan, III	6,488,331 B2	12/2002	Chen
D262,674 S	1/1982	Logan, III	6,494,530 B1	12/2002	Zheng
D267,057 S	11/1982	Koehm	D468,939 S	1/2003	Zheng
D270,557 S	9/1983	Williams	6,505,885 B1	1/2003	Tang
4,514,009 A	4/1985	Vanderminde et al.	6,547,322 B2	4/2003	Marx
4,605,261 A	8/1986	Lee	6,554,717 B2 *	4/2003	Cho 473/197
D287,909 S	1/1987	Weiss	D475,860 S	6/2003	Yang
4,652,047 A	3/1987	Chan	6,601,912 B1	8/2003	Chen
D290,557 S	6/1987	Salvati et al.	6,607,240 B2	8/2003	Zheng
4,671,566 A	6/1987	Knapp et al.	6,629,722 B1	10/2003	Tang
4,685,725 A	8/1987	Helfrich	6,634,705 B1	10/2003	Zheng
D292,048 S *	9/1987	Shaffer D6/363	6,637,811 B2	10/2003	Zheng
4,715,650 A	12/1987	Berman et al.	6,644,731 B2	11/2003	Tang
4,717,201 A	1/1988	Barras	6,669,281 B1	12/2003	Huang
4,789,123 A	12/1988	Mattsson	6,682,135 B2	1/2004	Zheng
4,826,241 A	5/1989	Barras	D486,310 S	2/2004	Goldy
4,867,505 A	9/1989	Parker	6,698,827 B2	3/2004	Le Gette et al.
4,889,383 A	12/1989	Jones	6,702,371 B2	3/2004	Zheng
4,934,638 A	6/1990	Davis	6,715,824 B2	4/2004	Zheng
D310,605 S	9/1990	Kwon	6,736,450 B2	5/2004	Miyagi
5,058,950 A	10/1991	Mann	6,755,462 B2	6/2004	Zheng
5,176,393 A	1/1993	Robertson et al.	6,779,838 B2	8/2004	Chang
5,246,265 A	9/1993	Nagan et al.	6,814,403 B2	11/2004	Zheng
5,320,404 A	6/1994	Le Gal	6,817,661 B2	11/2004	Zheng
5,335,967 A	8/1994	Vanderminde, Sr.	6,817,671 B1	11/2004	Zheng
5,494,333 A	2/1996	Wilson	6,820,927 B2	11/2004	Isom et al.
5,496,094 A	3/1996	Schwartzkopf et al.	6,824,207 B1 *	11/2004	Lin 297/16.1
5,499,857 A	3/1996	Lynch, Jr.	6,824,208 B2	11/2004	Zheng
5,522,642 A	6/1996	Herzog	6,824,210 B2	11/2004	Zheng
5,580,129 A	12/1996	Findlay	D499,258 S *	12/2004	Tseng D6/368
D380,306 S	7/1997	Lin	D500,605 S	1/2005	Schmidt et al.
D382,126 S	8/1997	Lee	6,840,573 B1 *	1/2005	Yao 297/16.1
D382,414 S	8/1997	Lee	6,840,574 B1	1/2005	Wu
5,718,473 A	2/1998	Lynch, Jr.	6,848,740 B1 *	2/2005	Reese 297/16.1
5,848,822 A	12/1998	Wu	D503,554 S	4/2005	Kay
5,893,605 A	4/1999	Chang	6,877,814 B2 *	4/2005	Lin 297/440.24
D411,387 S	6/1999	Zheng	6,883,862 B1 *	4/2005	Yao 297/16.1
			6,899,383 B2	5/2005	Hwang
			D507,892 S	8/2005	Zheng
			6,926,355 B2	8/2005	Le Gette et al.
			6,926,356 B2	8/2005	Chen

(56)

References Cited

U.S. PATENT DOCUMENTS

6,938,951 B1 9/2005 Tseng
 6,957,852 B1 10/2005 Hsieh
 D515,830 S 2/2006 Zheng
 6,997,634 B2 2/2006 Zheng
 7,000,983 B1 2/2006 Tsai
 D516,825 S 3/2006 Zheng
 D516,826 S 3/2006 Zheng
 D517,819 S 3/2006 Zheng
 7,011,372 B1* 3/2006 Hsieh 297/440.24
 7,017,985 B2 3/2006 Chen
 D522,263 S 6/2006 Hart
 7,073,852 B1 7/2006 Zheng
 D528,317 S 9/2006 Tseng
 7,100,877 B2 9/2006 Bourke et al.
 7,100,975 B1 9/2006 Zheng
 D529,304 S 10/2006 Le Gal
 D529,728 S 10/2006 Le Gal
 7,140,689 B2 11/2006 Zheng
 7,144,078 B2 12/2006 Hsieh
 7,178,864 B2* 2/2007 Hsieh 297/45
 7,219,955 B2 5/2007 Lu et al.
 7,229,128 B2 6/2007 Lee
 7,229,131 B2 6/2007 Chen
 7,264,245 B2* 9/2007 Cho 273/396
 D554,873 S* 11/2007 Ma D6/349
 D555,378 S* 11/2007 Tsai D6/368
 7,328,940 B2 2/2008 Zheng
 7,396,073 B2 7/2008 Zheng
 7,404,601 B2* 7/2008 Chen 297/16.2
 7,441,287 B2 10/2008 Zheng
 7,600,810 B2 10/2009 Chen et al.
 D608,104 S* 1/2010 Vonnegut D6/372
 7,648,421 B2* 1/2010 Yoon 473/197
 7,938,489 B2* 5/2011 Nazari 297/314
 D649,800 S* 12/2011 Lievore et al. D6/373
 D656,326 S* 3/2012 Soewondo D6/348
 D661,360 S 6/2012 Campanaro et al.
 8,282,509 B1* 10/2012 Michaelson et al. 473/456
 D677,920 S* 3/2013 Christakos D6/368
 D681,970 S* 5/2013 Christakos D6/368
 D683,156 S* 5/2013 Christakos D6/368
 D688,057 S* 8/2013 Christakos D6/368
 D691,384 S* 10/2013 Akkad D6/368
 D703,460 S 4/2014 Kreuzer et al.
 D711,151 S 8/2014 Christakos
 2002/0024240 A1 2/2002 Chen
 2002/0043822 A1 4/2002 Choi et al.
 2002/0074834 A1 6/2002 Summar et al.
 2002/0183128 A1* 12/2002 Cho 473/197
 2003/0006632 A1 1/2003 Ku
 2003/0015892 A1 1/2003 Wu
 2003/0020304 A1 1/2003 Zheng
 2003/0052518 A1 3/2003 Zheng
 2003/0057741 A1 3/2003 Zheng
 2003/0057747 A1 3/2003 Johnston
 2003/0060309 A1* 3/2003 Smith, IV 473/431
 2003/0094836 A1 5/2003 Chen
 2003/0111872 A1 6/2003 Zheng
 2003/0111874 A1 6/2003 Zheng
 2003/0127885 A1 7/2003 Tang
 2003/0234561 A1 12/2003 Zheng
 2004/0007903 A1 1/2004 Chang
 2004/0036323 A1 2/2004 Hwang
 2004/0066075 A1 4/2004 Yeh
 2004/0094996 A1 5/2004 Zheng

2004/0094997 A1 5/2004 Zheng
 2004/0113476 A1 6/2004 Chang
 2004/0130190 A1 7/2004 Zheng
 2004/0135405 A1 7/2004 Zheng
 2004/0232740 A1 11/2004 Enge
 2004/0245810 A1 12/2004 Tseng
 2005/0077758 A1 4/2005 Reese
 2005/0088018 A1* 4/2005 Yao 297/16.1
 2005/0236873 A1 10/2005 Edward
 2005/0248202 A1 11/2005 Zheng
 2006/0186711 A1 8/2006 Phipps
 2007/0029846 A1 2/2007 Cohen
 2007/0102974 A1 5/2007 Chen
 2007/0187998 A1* 8/2007 Chen 297/45
 2007/0200395 A1 8/2007 Zheng
 2007/0267901 A1 11/2007 Zheng
 2008/0224504 A1 9/2008 Fargason
 2008/0231088 A1 9/2008 Zheng
 2010/0164256 A1 7/2010 Salisbury
 2010/0231015 A1 9/2010 Lundeen

FOREIGN PATENT DOCUMENTS

CN 2117779 U 10/1992
 CN 2137107 Y 6/1993
 CN 2179041 Y 10/1994
 CN 2188885 Y 2/1995
 CN 2196945 Y 5/1995
 CN 1139537 A 1/1997
 CN 2326083 Y 6/1999
 CN 2328266 Y 7/1999
 CN 2339063 Y 9/1999
 CN 2349884 Y 11/1999
 CN 2367154 Y 3/2000
 EP 139306 A1 5/1985
 EP 997090 A1 5/2000
 FR 2833824 A1 6/2003
 FR 2837081 A1 9/2003
 GB 599760 A 3/1948
 GB 2022405 A 12/1979
 GB 2025213 A 1/1980
 GB 2331233 A 5/1999
 JP 38-12532 6/1938
 JP 50123508 A 9/1975
 JP 51127856 A 11/1976
 JP 55120347 A 9/1980
 JP 2001070077 A 3/2001
 JP 2002165667 A 6/2002
 JP 2002233429 A 8/2002
 JP 2002360371 A 12/2002
 JP 2004105557 A 4/2004
 WO 2004021835 A1 3/2004

OTHER PUBLICATIONS

U.S. Appl. No. 13/570,472 by Akkad, filed Aug. 9, 2012.
 U.S. Appl. No. 29/434,983 by Akkad, filed Oct. 18, 2012.
 Office Action issued Jan. 28, 2014 in CA Application No. 2,791,594.
 Office Action issued Sep. 20, 2013 in U.S. Appl. No. 13/570,472 by Akkad.
 Office Action issued Jan. 14, 2014 in U.S. Appl. No. 13/570,472 by Akkad.
 U.S. Appl. No. 29/483,488 by Akkad, filed Feb. 28, 2014.
 U.S. Appl. No. 29/478,866 by Akkad, filed Jan. 9, 2014.
 U.S. Appl. No. 29/493,606 by Akkad, filed Jun. 11, 2014.
 U.S. Appl. No. 29/493,607 by Akkad, filed Jun. 11, 2014.

* cited by examiner

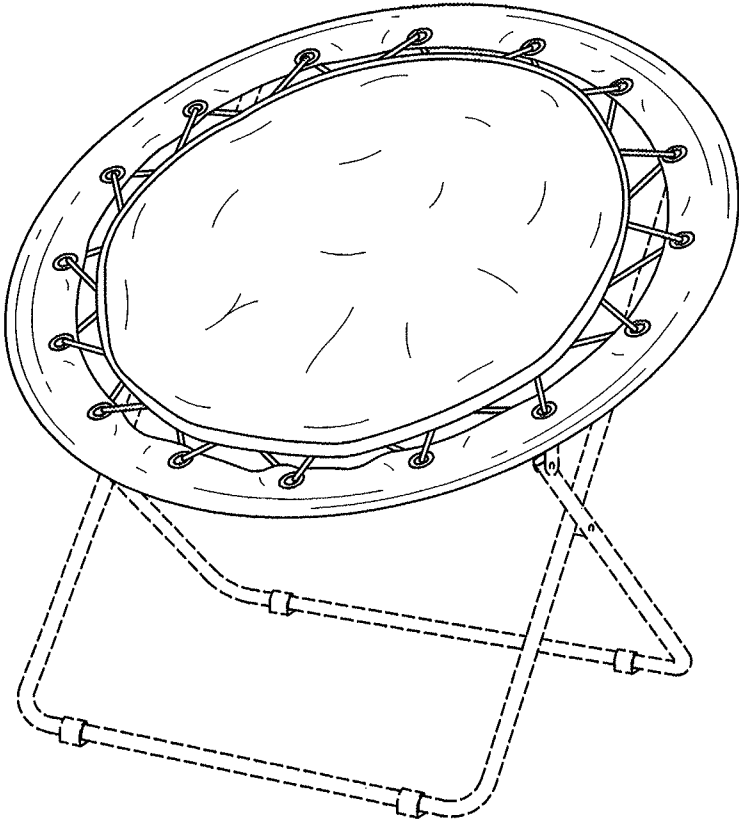

Fig. 1

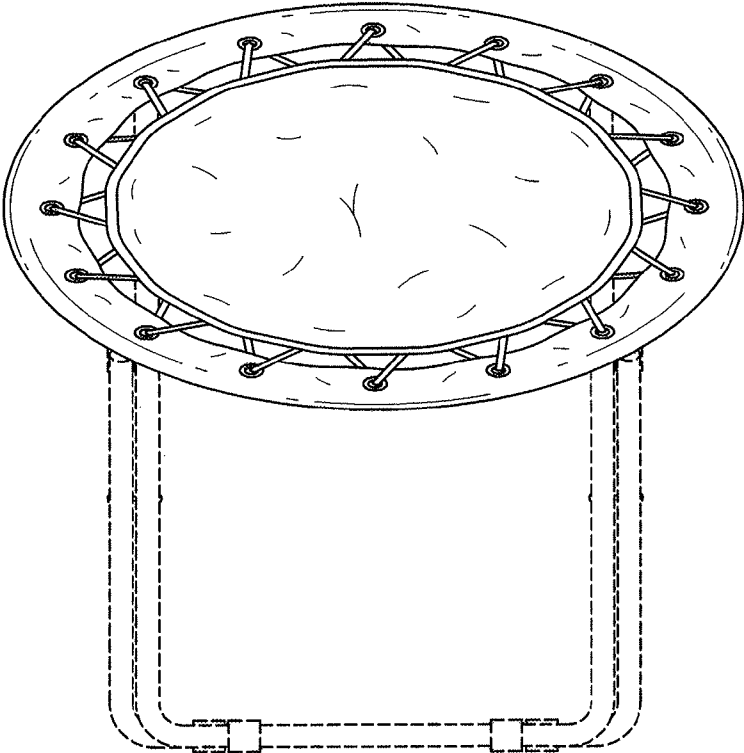

Fig. 2

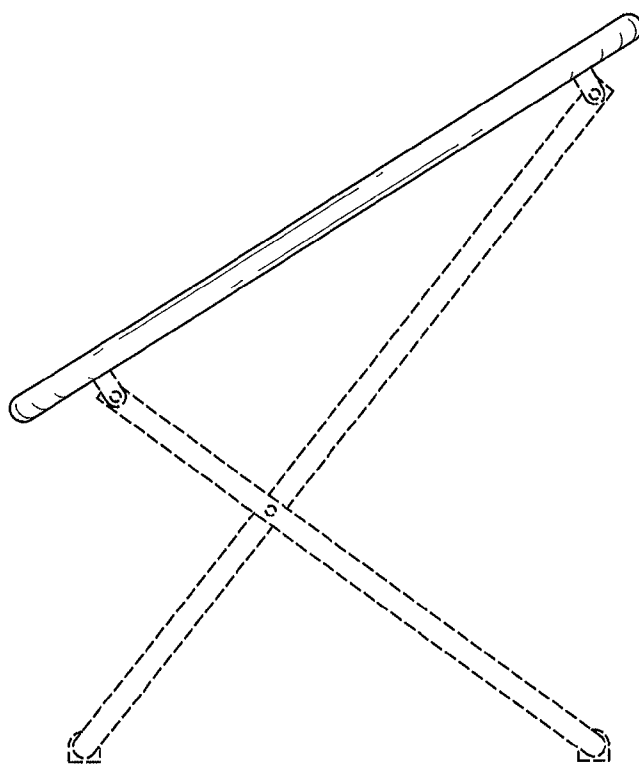

Fig. 3

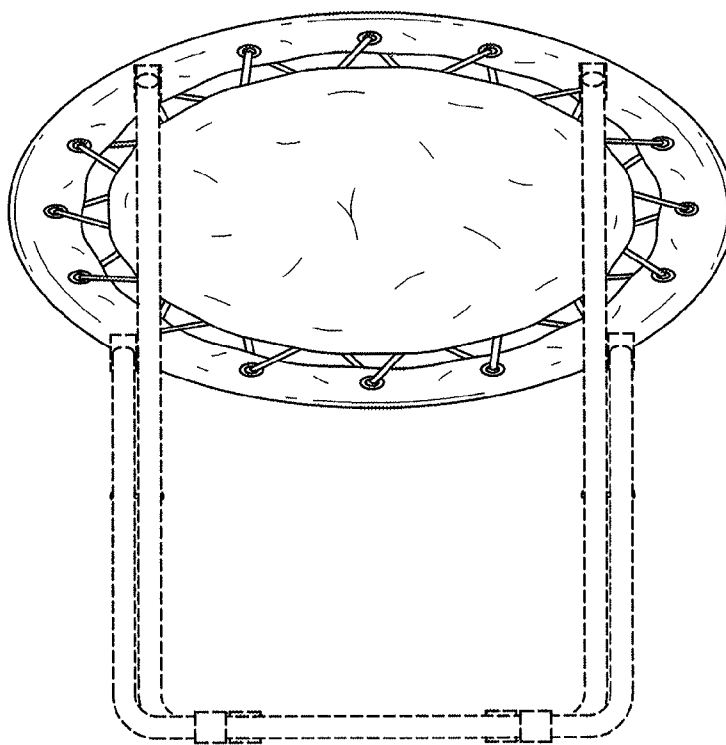

Fig. 4

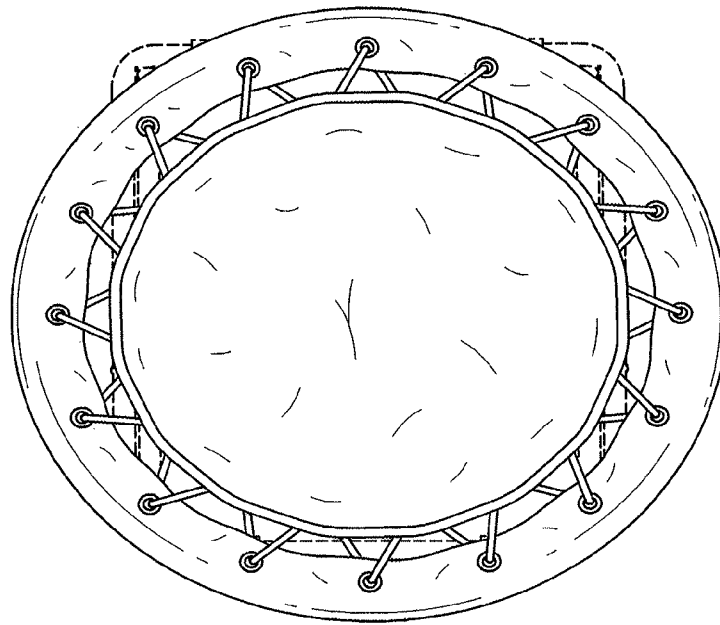

Fig. 5

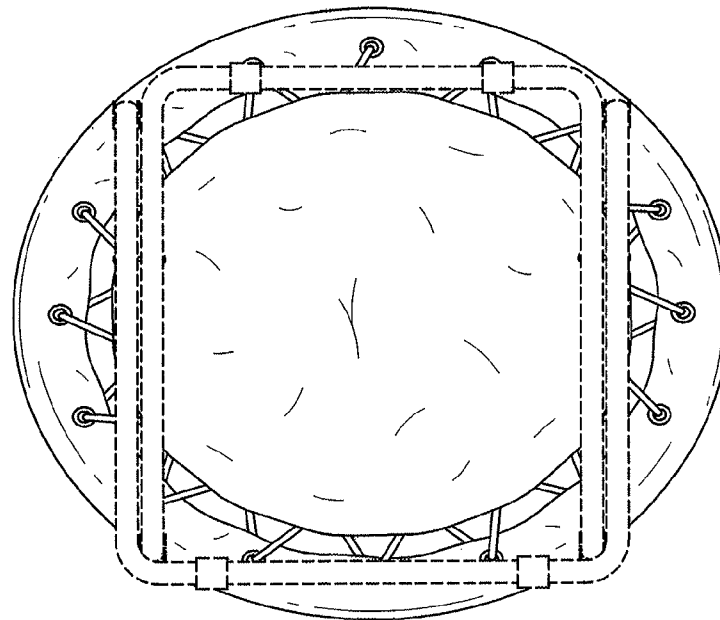

Fig. 6

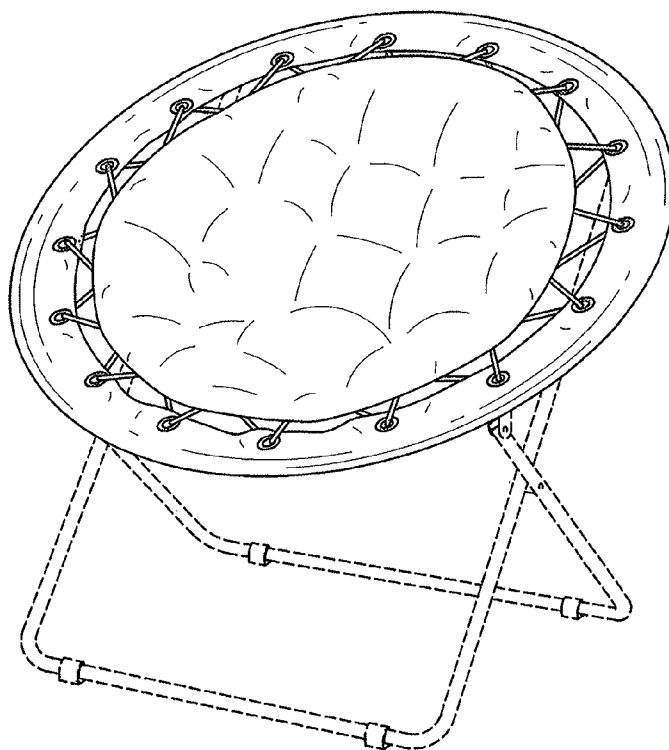

Fig. 7

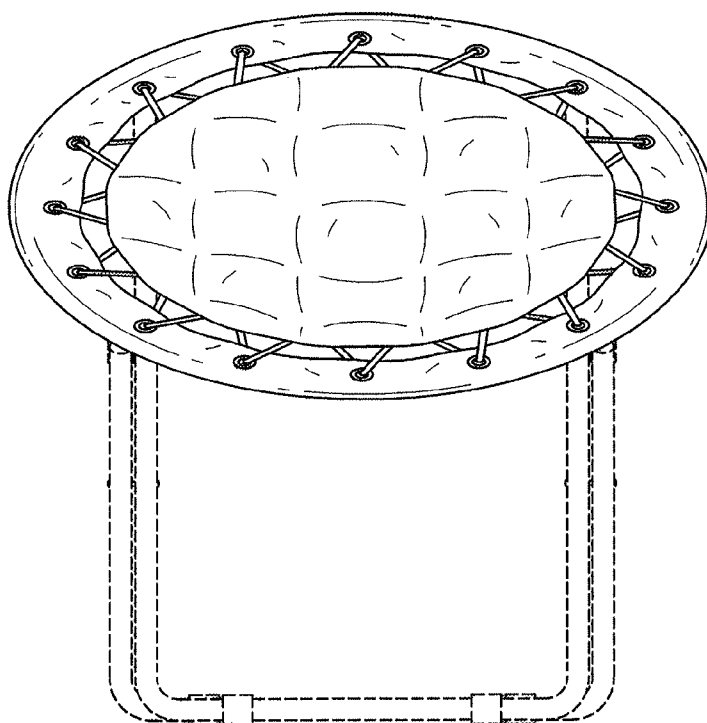

Fig. 8

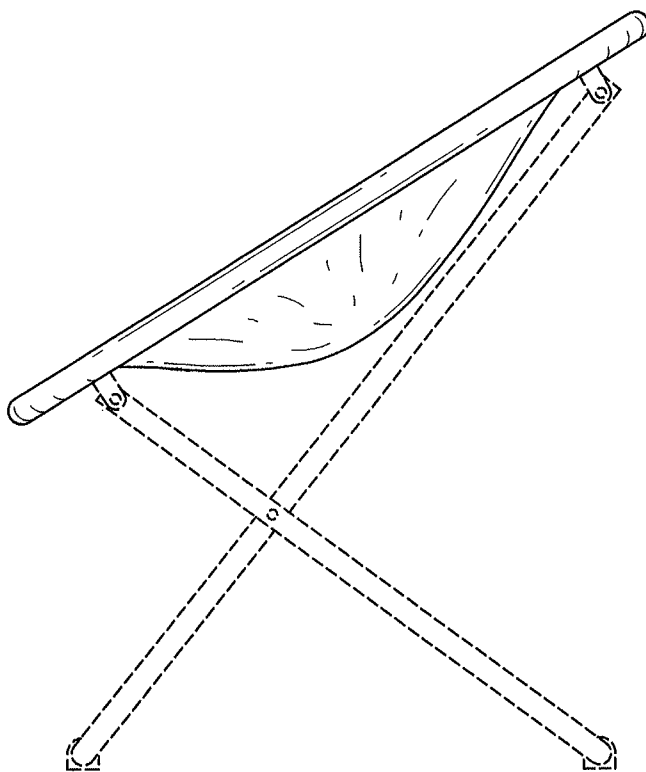

Fig. 9

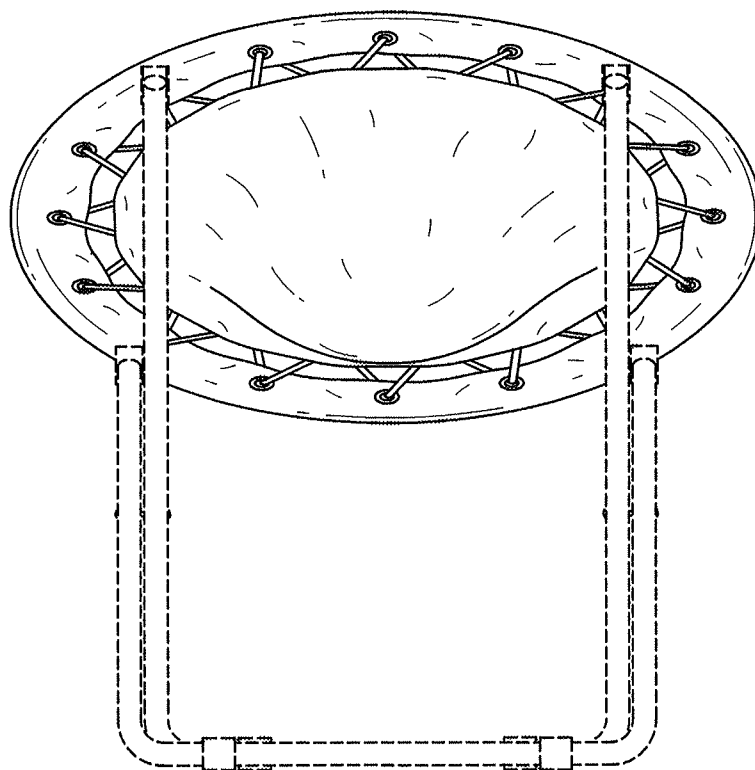

Fig. 10

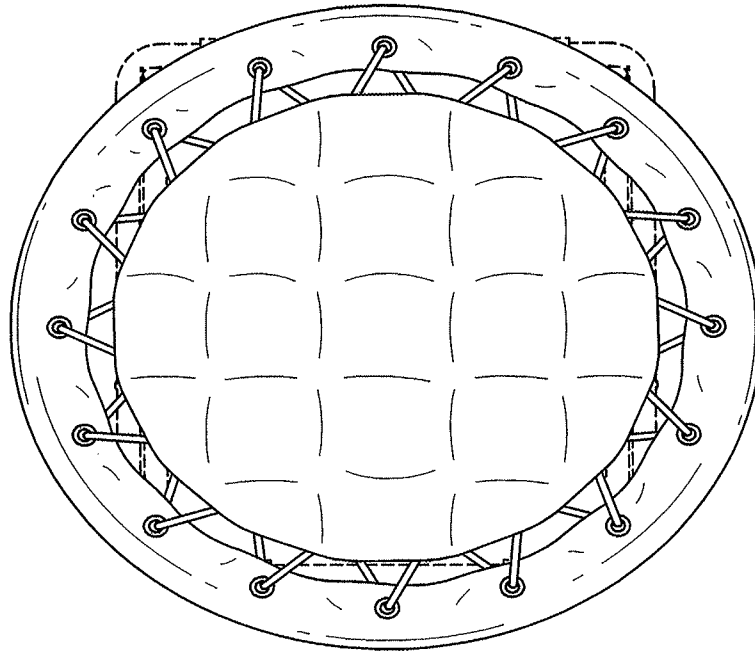

Fig. 11

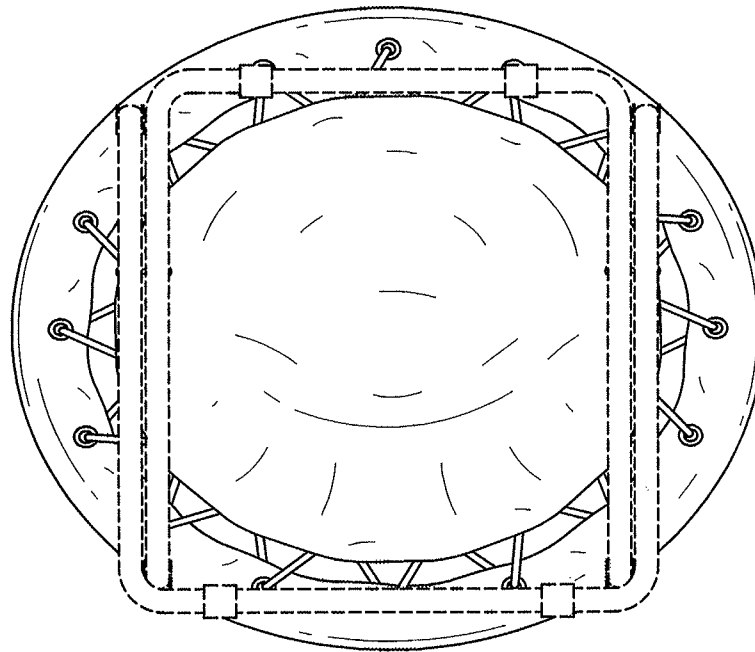

Fig. 12