



US00D333166S

# United States Patent [19]

[11] Patent Number: **Des. 333,166**

Caveza

[45] Date of Patent: **\*\* Feb. 9, 1993**

- [54] **ELECTRONIC CAROUSEL**
- [75] Inventor: **Martin Caveza**, Redondo Beach, Calif.
- [73] Assignee: **Mattel, Inc.**, El Segundo, Calif.
- [\*\*] Term: **14 Years**
- [21] Appl. No.: **592,054**
- [22] Filed: **Oct. 1, 1990**
- [52] U.S. Cl. .... **D21/64; D17/24; D21/249**
- [58] Field of Search ..... **D21/64, 249, 92; D17/24; 446/236, 242, 243; 472/1, 6, 14**

- D. 264,982 6/1982 Jackson ..... D21/249 X
- 2,657,928 11/1953 McDonald ..... 472/6
- 3,191,930 6/1965 Cottrell et al. .... 472/6
- 3,279,793 10/1966 Lakin ..... 472/6

*Primary Examiner*—Bernard Ansher  
*Assistant Examiner*—Dominic Simone  
*Attorney, Agent, or Firm*—Roy A. Ekstrand

### [57] CLAIM

The ornamental design for an electronic carousel, as shown and described.

### DESCRIPTION

FIG. 1 is a front elevational view of an electronic carousel showing my new design;  
 FIG. 2 is a right side elevational view thereof;  
 FIG. 3 is a left side elevational view thereof;  
 FIG. 4 is a rear elevational view thereof;  
 FIG. 5 is a top plan view thereof;  
 FIG. 6 is a bottom plan view thereof; and,  
 FIG. 7 is a rear perspective view thereof.

- [56] **References Cited**
- U.S. PATENT DOCUMENTS**
- D. 92,046 4/1934 Steiner ..... D21/249 X
- D. 143,076 12/1945 Kellerman ..... D21/92 X
- D. 158,192 4/1950 Hettick ..... D21/249 X

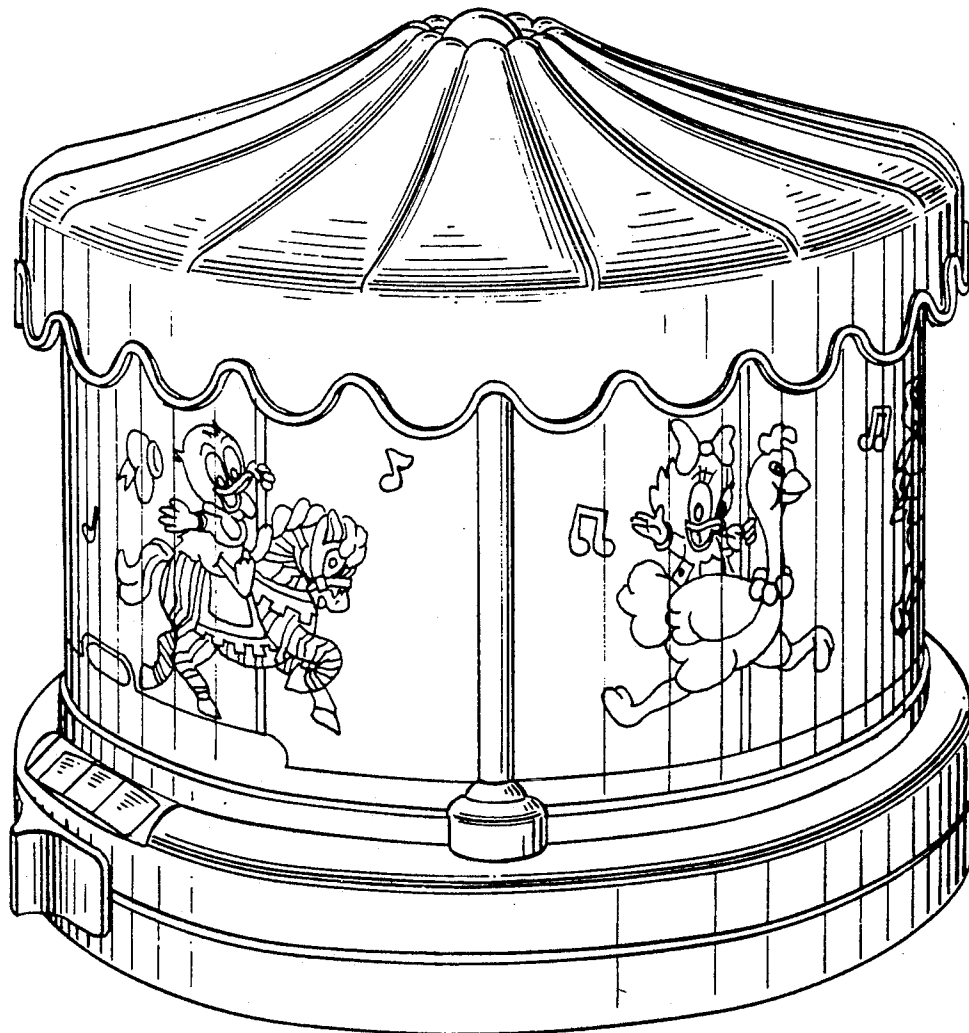

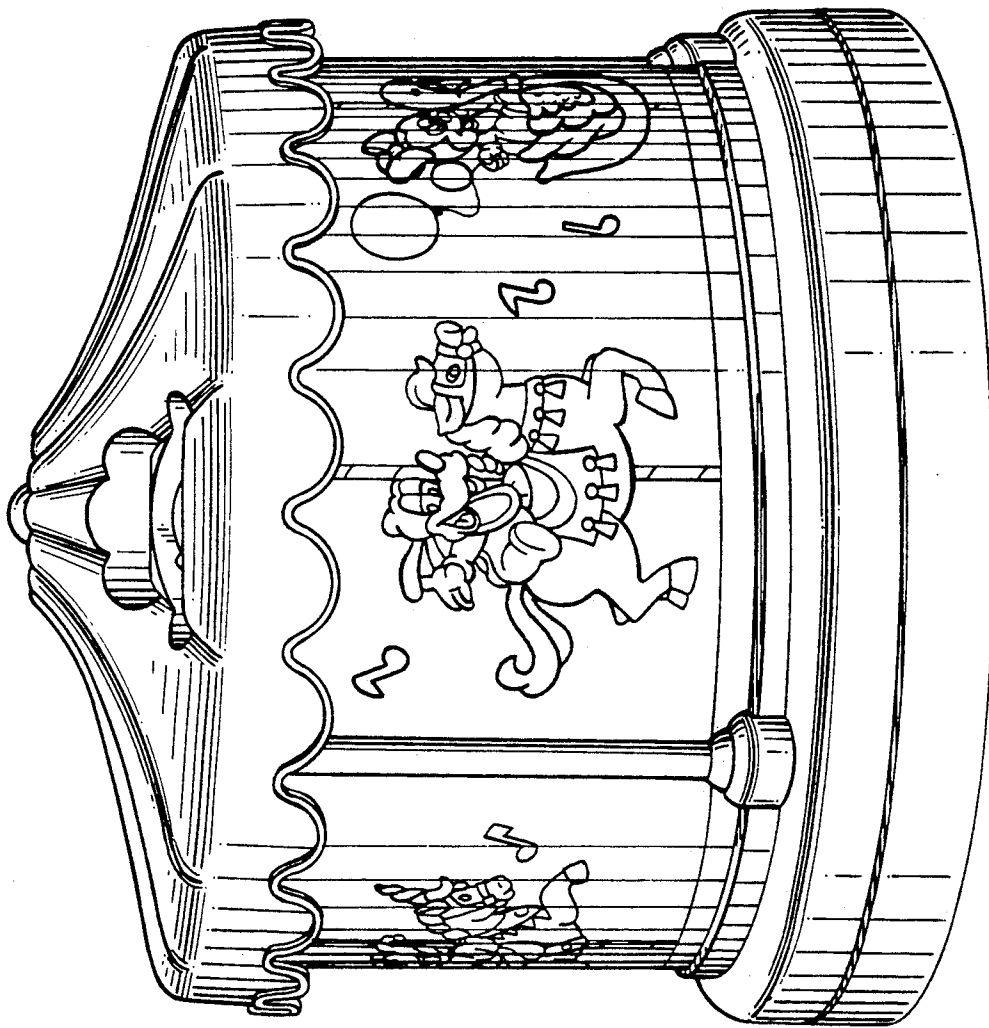

FIG. 1

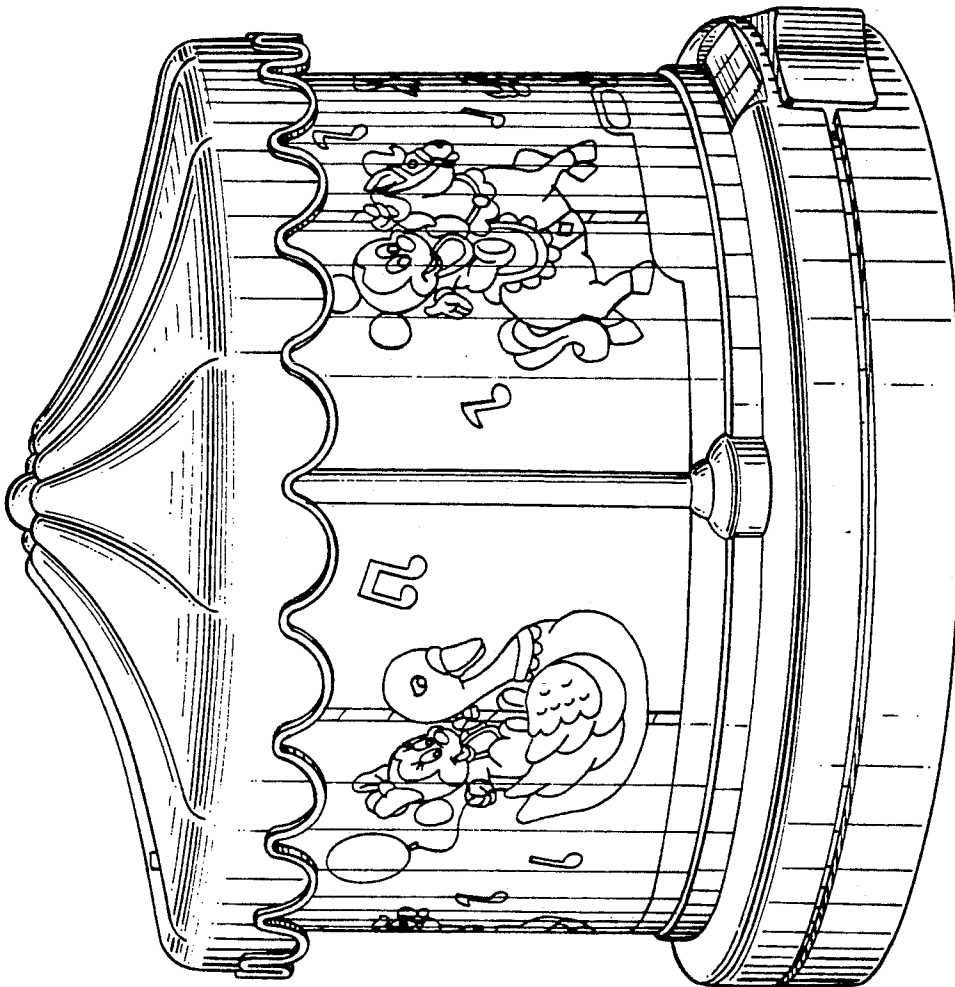

FIG. 2

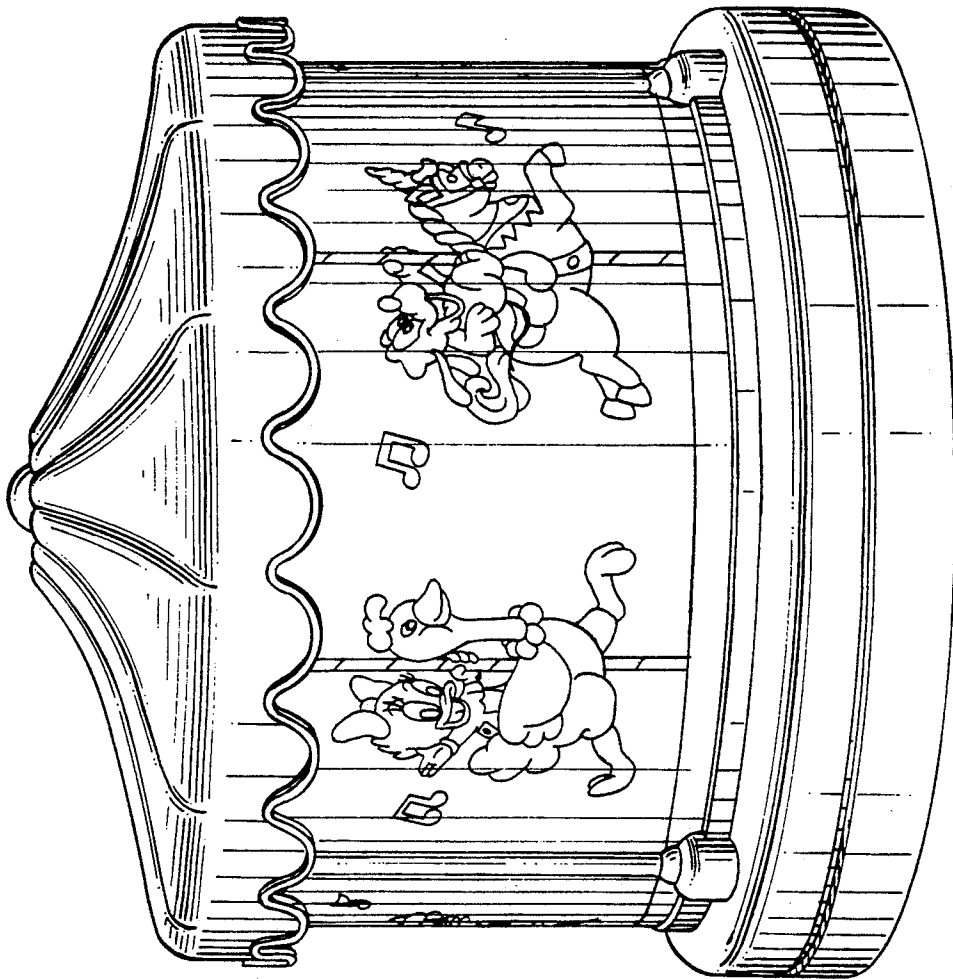

FIG. 3

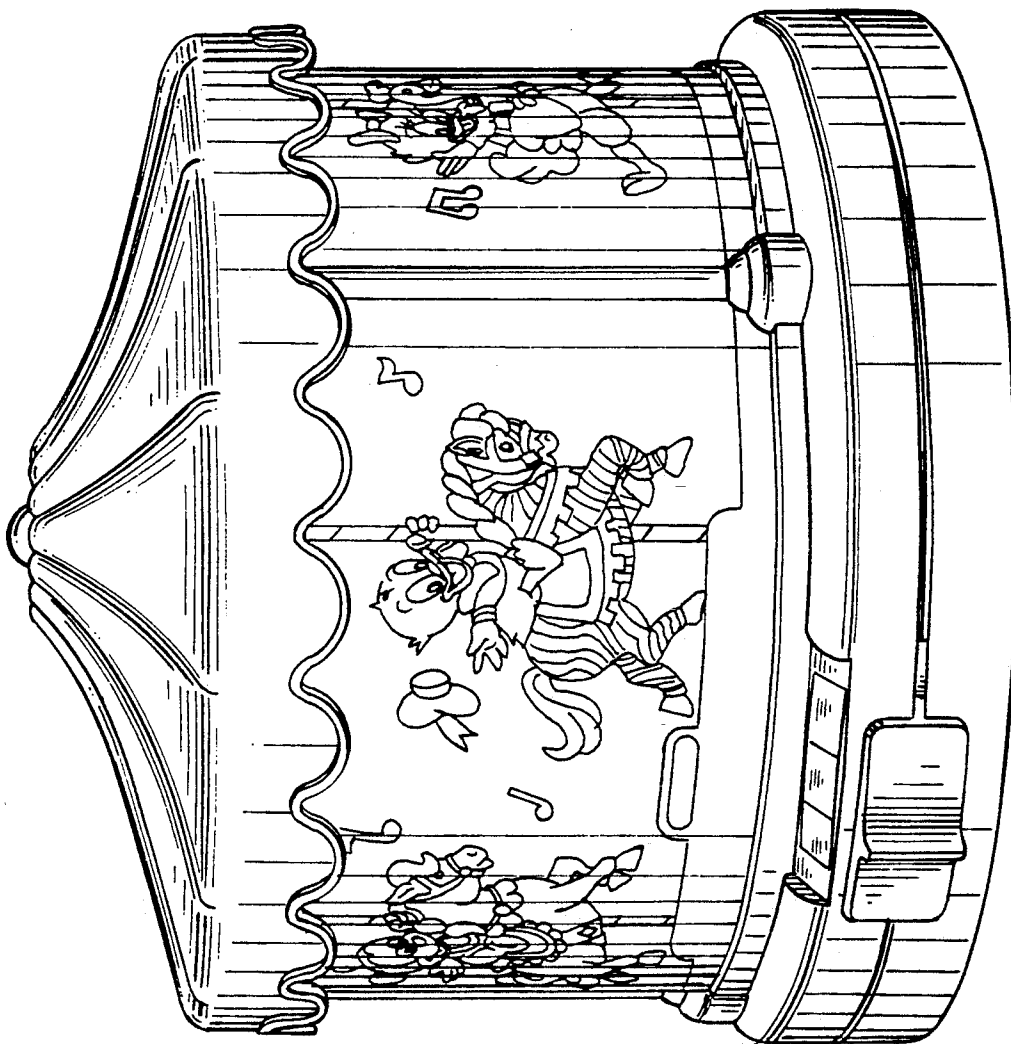

FIG. 4

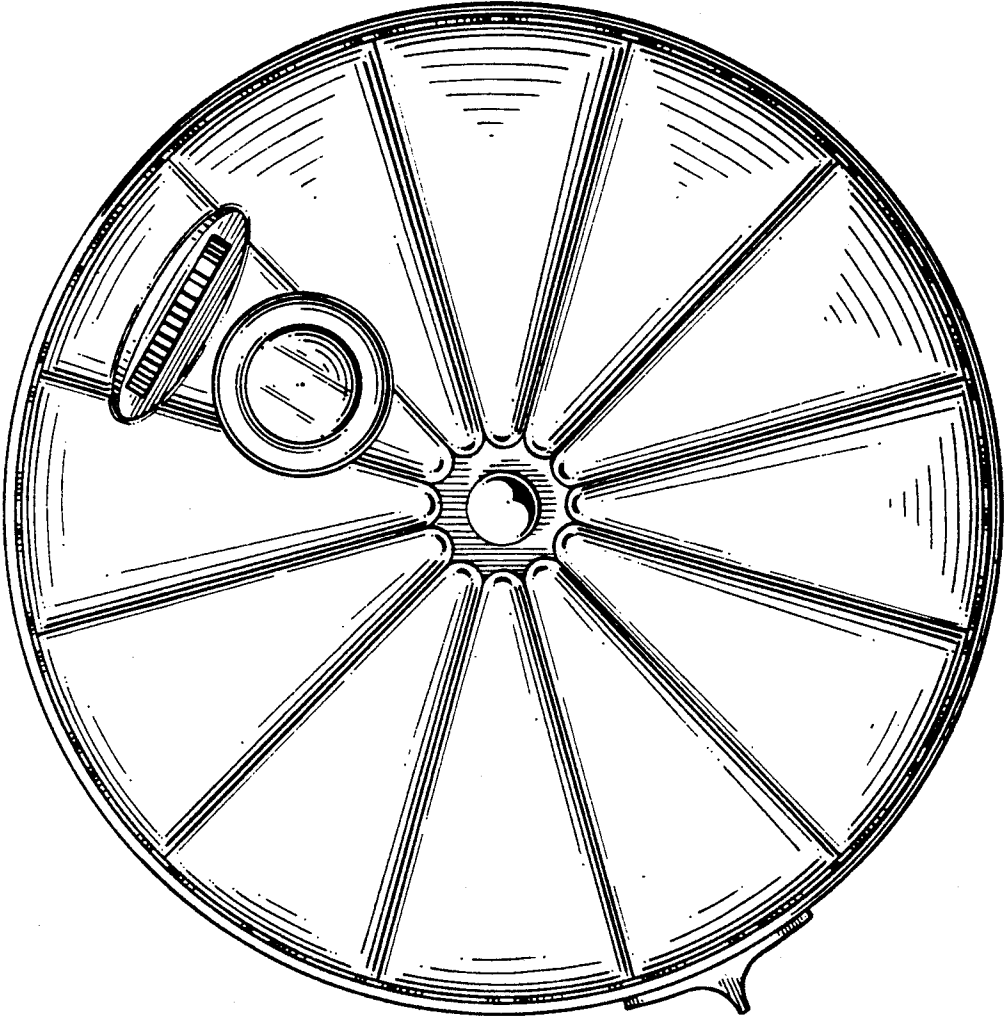

FIG. 5

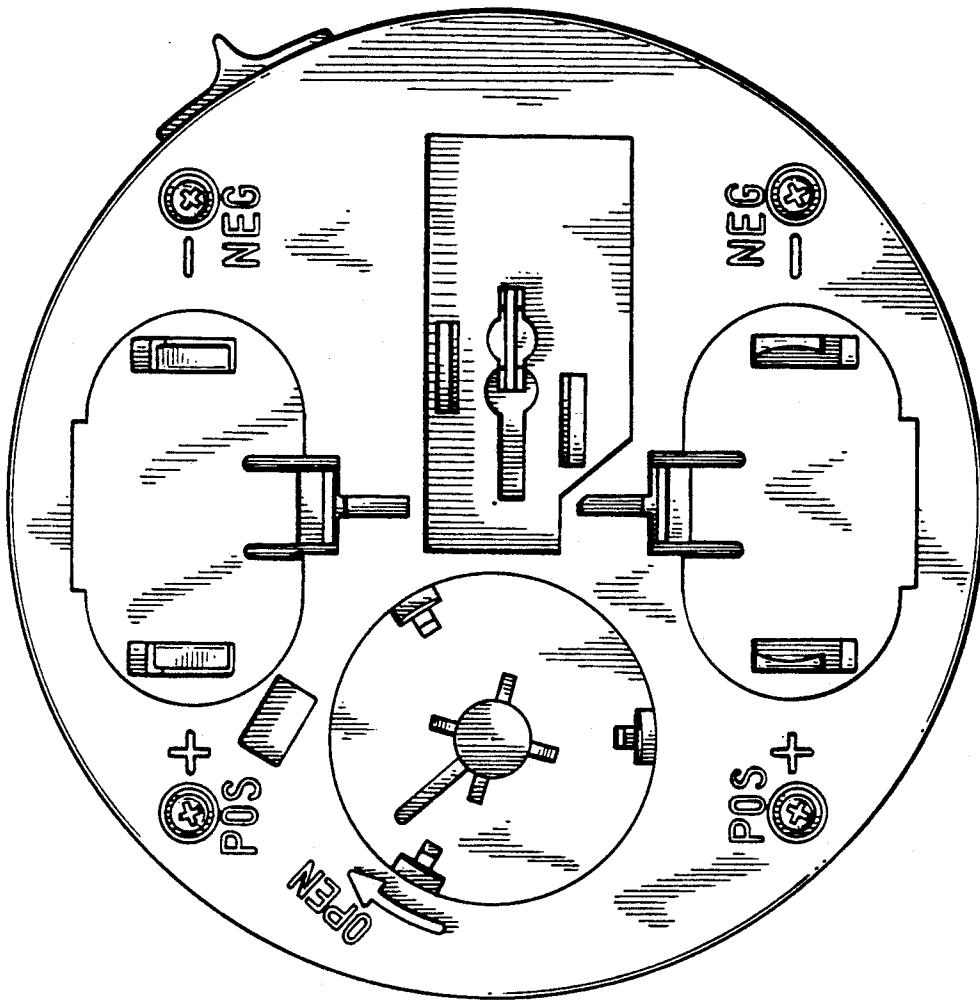

FIG. 6

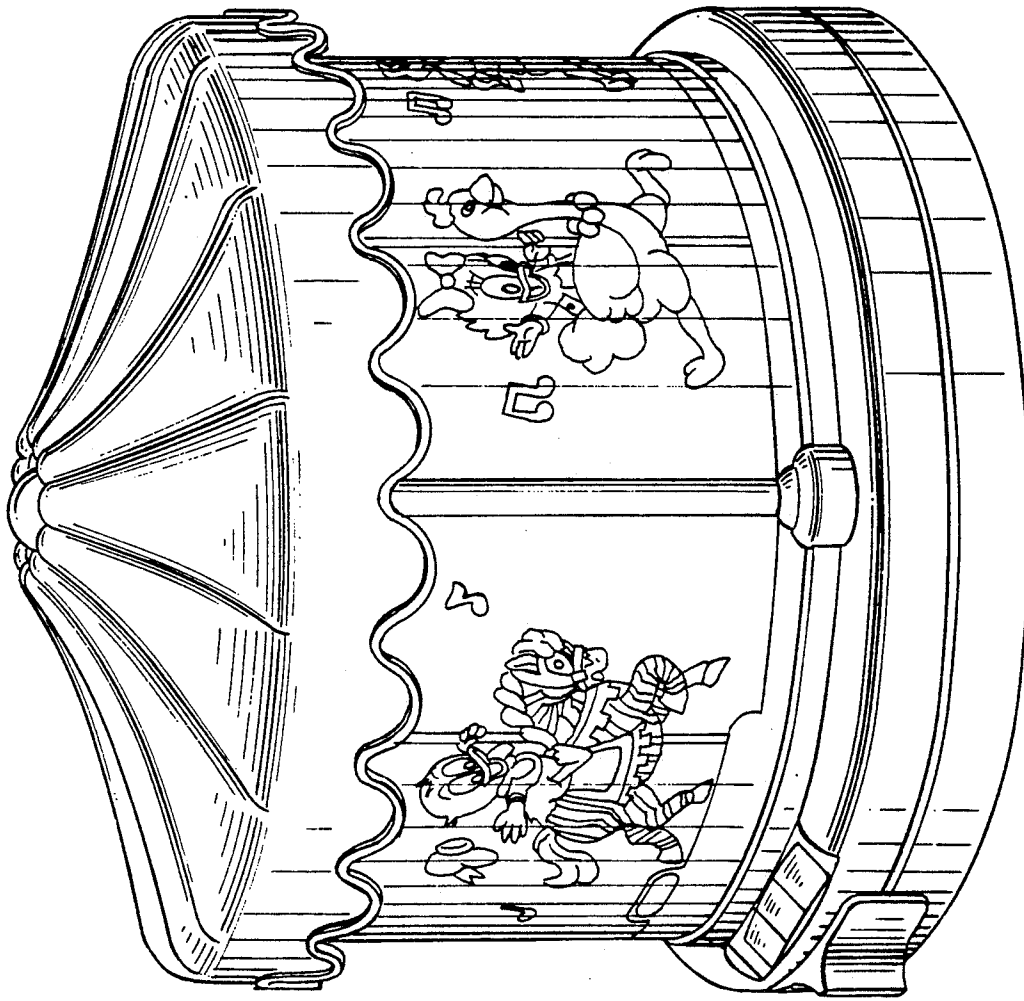

FIG. 7