



US00D802501S

(12) **United States Design Patent** (10) **Patent No.:** **US D802,501 S**
Han (45) **Date of Patent:** **** Nov. 14, 2017**

(54) **FRONT BUMPER OF CAR**
(71) Applicant: **GM GLOBAL TECHNOLOGY OPERATIONS LLC**, Detroit, MI (US)
(72) Inventor: **Hongchul Han**, Incheon (KR)
(73) Assignee: **GM GLOBAL TECHNOLOGY OPERATIONS LLC**, Detroit, MI (US)
(**) Term: **15 Years**

D617,700 S * 6/2010 Nishio D12/169
D756,276 S * 5/2016 Minamisawa D12/169
D766,788 S * 9/2016 Kim D12/169
D770,950 S * 11/2016 Bucher D12/169
D770,951 S * 11/2016 Park D12/169
D771,532 S * 11/2016 Kapitonov D12/169
D772,766 S * 11/2016 Kozub D12/169
D773,350 S * 12/2016 Lee D12/169
D787,990 S * 5/2017 Kozub D12/169
D789,850 S * 6/2017 Svensson D12/169
D789,851 S * 6/2017 Svensson D12/169

* cited by examiner

(21) Appl. No.: **29/578,078**
(22) Filed: **Sep. 19, 2016**

Primary Examiner — Melody N Brown
(74) *Attorney, Agent, or Firm* — Browdy and Neimark, PLLC

(30) **Foreign Application Priority Data**
Mar. 18, 2016 (KR) 30-2016-0012863
(51) **LOC (10) CL.** **12-16**
(52) **U.S. CL.**
USPC **D12/169**
(58) **Field of Classification Search**
USPC D12/169, 216, 90-92, 86, 171, 196, 163;
293/102, 113, 115, 117, 120; 296/180.1,
296/180.2
CPC B60R 19/02; B60R 19/04; B62D 25/08
See application file for complete search history.

(57) **CLAIM**
The ornamental design for a front bumper of car, as shown and described.

(56) **References Cited**
U.S. PATENT DOCUMENTS
D612,297 S * 3/2010 Peters D12/92
D615,458 S * 5/2010 Thompson D12/92

DESCRIPTION
FIG. 1 is a perspective view of a front bumper of car showing my new design;
FIG. 2 is a front elevation view thereof;
FIG. 3 is a rear elevation view thereof;
FIG. 4 is a left side elevation view thereof;
FIG. 5 is a right side elevation view thereof;
FIG. 6 is a top plan view thereof; and,
FIG. 7 is a bottom plan view thereof.

1 Claim, 7 Drawing Sheets

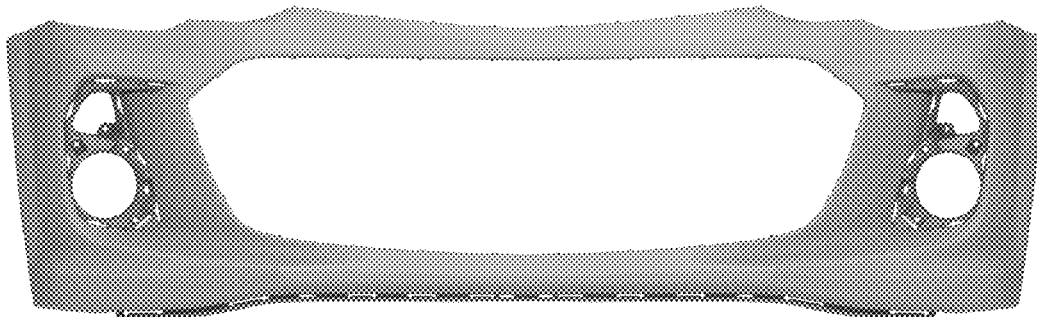

FIG. 1

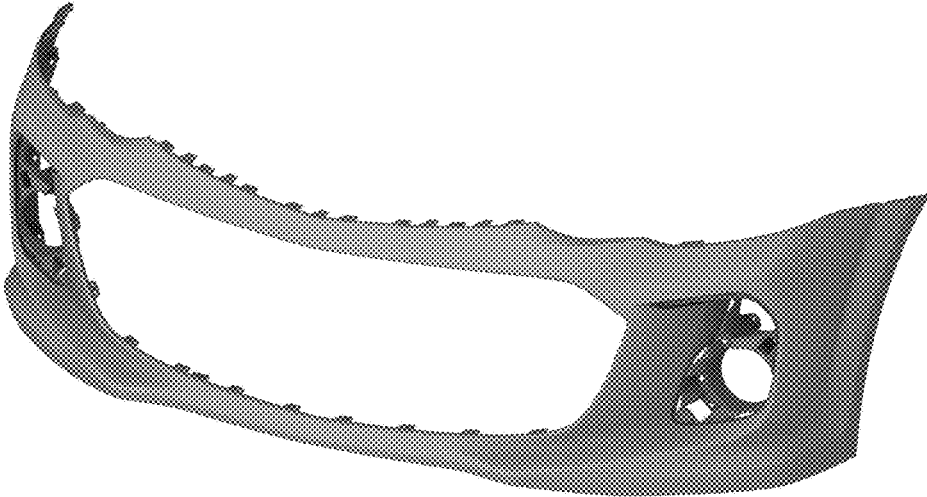

FIG. 2

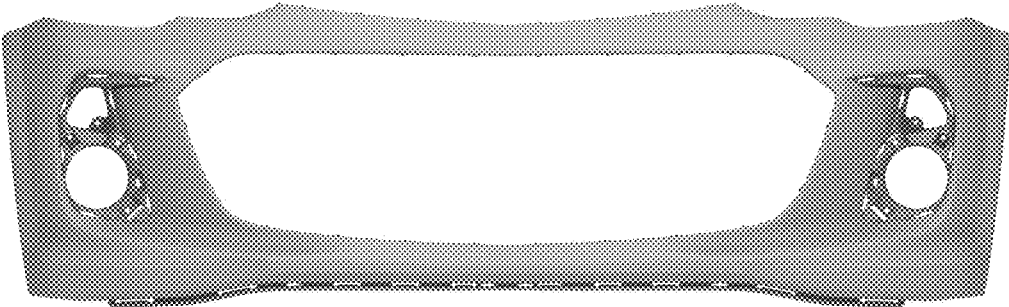

FIG. 3

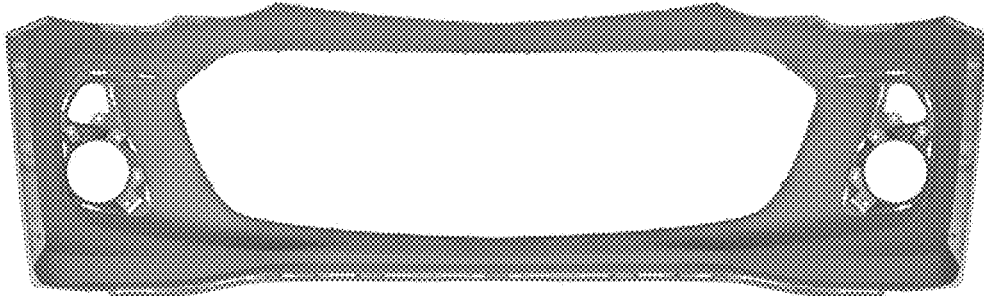

FIG. 4

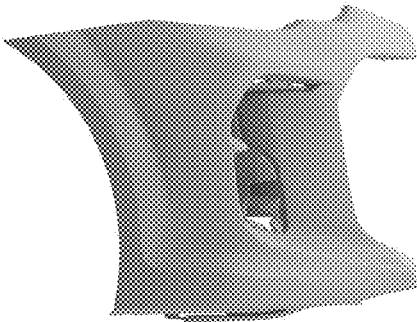

FIG. 5

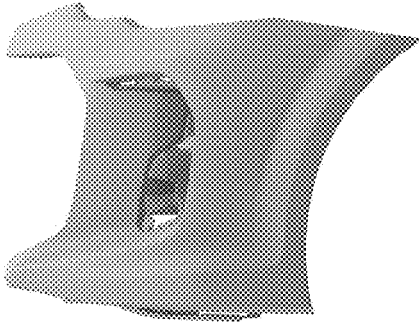

FIG. 6



FIG. 7

