

(12) UK Patent Application (19) GB (11) 2 171 119 A

(43) Application published 20 Aug 1986

(21) Application No 8601905

(22) Date of filing 27 Jan 1986

(30) Priority data

(31) 696836 (32) 31 Jan 1985 (33) US

(51) INT CL⁴
C23C 14/56 B65G 13/00 13/06

(52) Domestic classification (Edition H)
C7F 1A 1V1 1V2 6E2
B8A 41 42 4G1X 4H2 4JB 4M5
B8L 24 28 44 49 52 A
U1S 1663 1877 2319 B8A B8L C7F

(56) Documents cited
GB 1594525
US 4405435
US 4047624

(71) Applicant
The BOC Group Inc. (USA-Delaware),
85 Chestnut Ridge Road, Montvale, New Jersey 07645,
United States of America

(72) Inventors
Albany D Grubb,
Alex Boozenny,
Walter G. Overacker

(74) Agent and/or address for service
Michael Wickham, BOC Limited, PO Box 39, GT West
House, Great West Road, Brentford, Middlesex
TW8 9DQ

(58) Field of search
C7F
B8A
Selected US specifications from IPC sub-classes C23C
B65G

(54) Vacuum processing apparatus and method

(57) A vacuum processing apparatus as illustrated in Fig. 1 includes a processing chamber 10 and a second chamber 16 which contains a workpiece transporting device 50 comprising two conveyors 52 and 54 on a common frame 60 and a means 70 eg acting through a seal in the chamber wall for aligning the frame and each conveyor to transfer workpieces in opposite directions through the second chamber. The second chamber 16 may be an end lock with access to the outside or an intermediate lock or holding chamber between the processing chamber 10 and an end lock 18. A first gate valve 20 is operable to interconnect chambers 10 and 16, and a second gate valve 24 is operable to provide access to the second chamber 16. Preferably, the conveyors 52 and 54 comprise two parallel sets of horizontal rollers and an elevator for selectively aligning each set of rollers with a pass line 48 along which workpieces are transferred between the end lock 18 and the chamber 16 and between the chamber 16 and the processing chamber 10. The rollers of an aligned set may be driven by a magnetic coupling through the wall of chamber 16.

The method involves the successive steps of:— a) processing a workpiece; b) transporting the processed workpiece from a first conveyor in a first chamber to a first level of a multi-level conveyor in a second chamber; c) aligning the second level of the multi-level with the first conveyor; d) transporting a first unprocessed workpiece from the second level onto the first conveyor, then sealing the first chamber from the second chamber; e) transporting a second unprocessed workpiece from a second conveyor outside the second chamber onto the second level; f) aligning the first level with the second conveyor; g) transporting the processed workpiece from the first level to the second conveyor; and h) sealing the second chamber.

FIG. 1

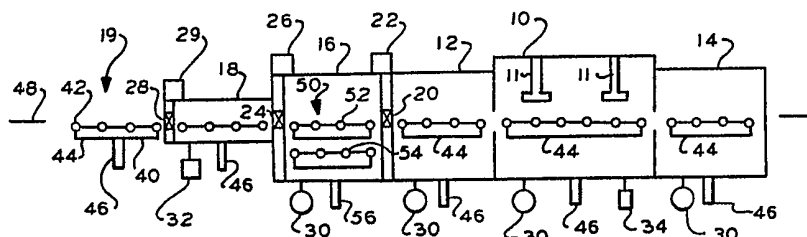

The drawings originally filed were informal and the print here reproduced is taken from a later filed formal copy.

GB 2 171 119 A

FIG. 1

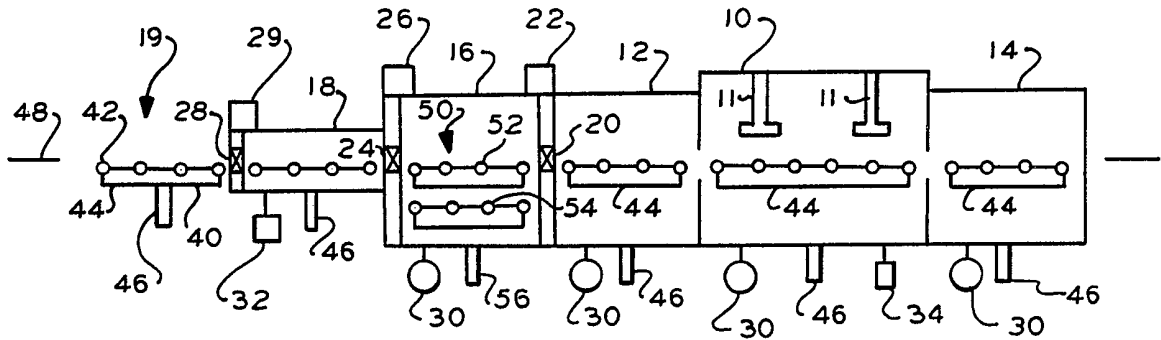

FIG. 2

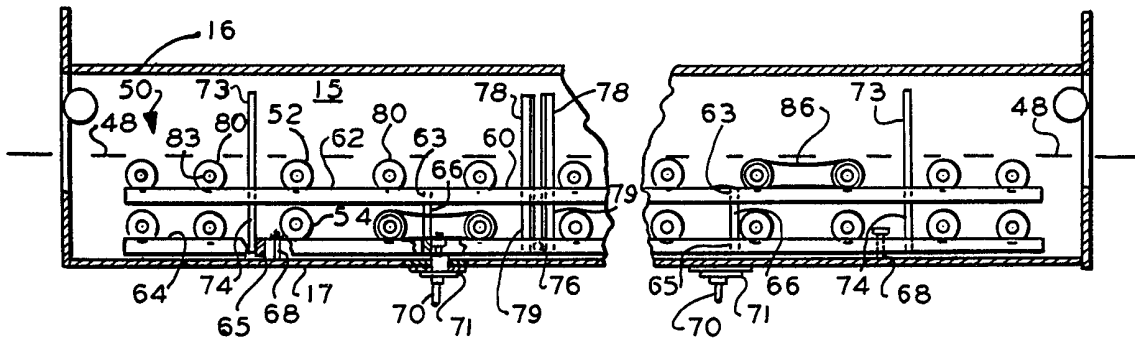

FIG. 3a

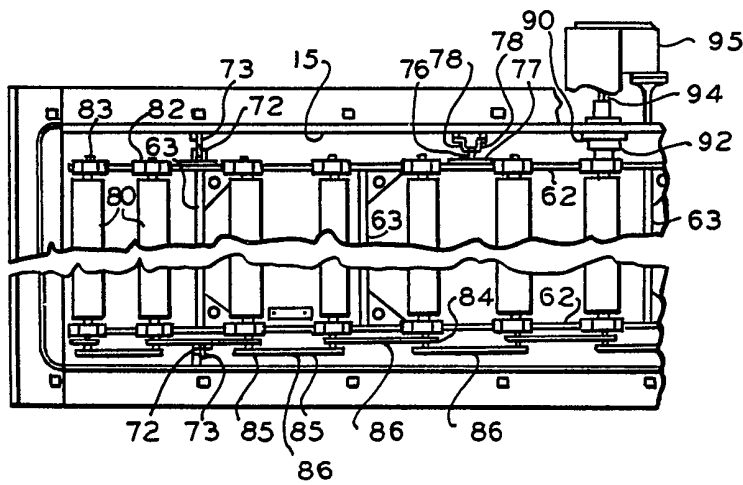

FIG. 3b

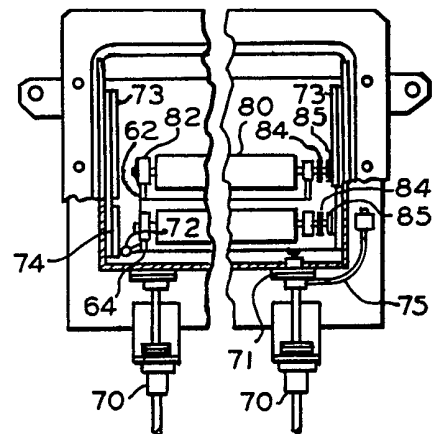
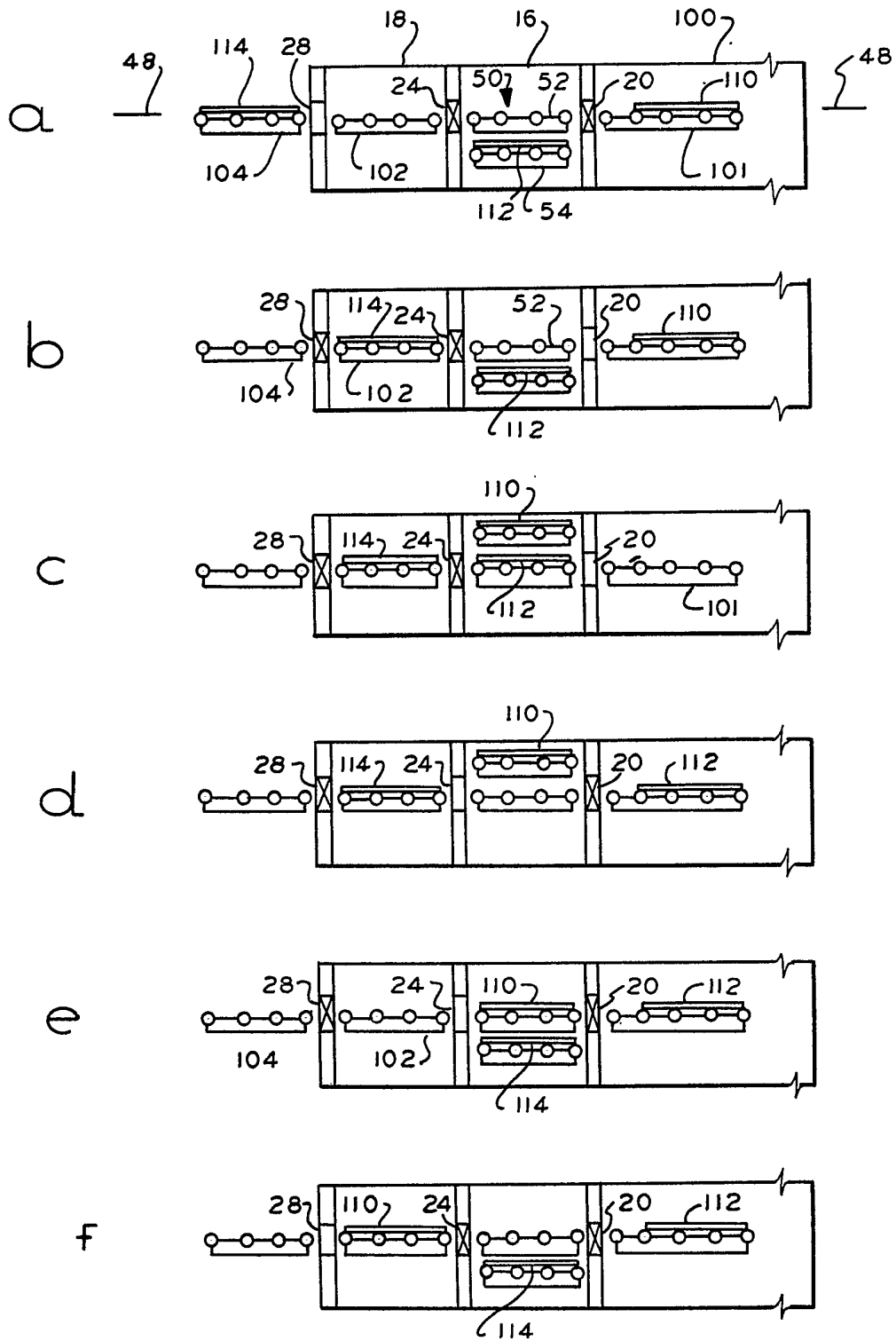

FIG. 4



SPECIFICATION

Vacuum processing apparatus and method

5 This invention relates to transporting workpieces into and out of a vacuum processing apparatus.

The time required to transport workpieces into and out of vacuum apparatus and to pump down to a suitable pressure is frequently a limiting factor in the rate at which workpieces can be processed. This is particularly true in high rate deposition processes where the coating time for an individual substrate is sometimes short compared to the time required to sufficiently evacuate the coating chamber. Coating apparatus has been developed where workpieces or substrates are passed through separate vacuum locks on their way into and out of a coating or processing chamber. This increases the production rate because the volume of the lock can be minimized and processing can continue for successive substrates without exposure of the processing chamber to atmospheric pressure. U.S. Patent 3,945,903 to Svendor et al discloses a vacuum coating system comprising entrance and exit locks and roller conveyors for transporting glass sheets through the system.

In certain situations, the expense of a complete double-ended system with a vacuum lock at the both the entrance and exit of the coating chamber is not warranted. An alternative is to provide a single lock and a reversible conveyor so that workpieces can enter and leave the processing chamber via the same lock. Such a system is called single-ended coater. U.S. patent 4,405,435 to Tateishi et al discloses a single-ended vacuum coating system having multi-level workpiece cassettes and cassette elevators in both the lock and an intermediate chamber between the lock and the sputter coating chamber.

The invention provides a vacuum processing apparatus as claimed in claim 1. The invention also provides a method as claimed in claim 8 of transporting workpieces into and out of a vacuum processing apparatus. The apparatus includes a processing chamber and a second chamber which contains a workpiece transporting device comprising two conveyors on a common frame and a means for aligning the frame and each conveyor to transfer workpieces in opposite directions through the second chamber. The second chamber may be an end lock with access to the outside or an intermediate lock or holding chamber between the processing chamber and an end lock. Preferably, the conveyors comprise two parallel sets of horizontal rollers and an elevator for selectively aligning each set of rollers with a pass line along which workpieces are transferred between an end lock and a holding chamber and between a holding chamber and a processing chamber.

The invention will now be described by way of example with reference to the accompanying drawings in which;

Figure 1 is a schematic representation of a side view of a vacuum coating apparatus incorporating the invention.

65 Figure 2 is a side view, partially in cross-section,

of a holding chamber incorporating a two-level workpiece transporting device according to the invention.

70 Figure 3a is a plan view of the holding chamber and workpiece transporting device of Fig. 2.

Figure 3b is an end view, partially in cross section, of the holding chamber and workpieces transporting device of Figure 2.

75 Figures 4 (a) to (f) are schematic views of a vacuum processing system comprising a processing chamber, a holding chamber and a vacuum lock which illustrate the method according to the invention.

80 Figure 1 illustrates a single-ended vacuum processing apparatus comprising a processing chamber 10, a holding chamber 16, and a lock chamber 18. The vacuum process may be a coating process in which workpieces are transported from an entry buffer 12, passed a number of sputter coating sources 11 in the processing chamber and into an overrun buffer 14. The workpieces may be transported back and forth through the processing chamber 10 as required.

The processing area of the apparatus is separated 90 from the holding chamber 16 by a first internal gate valve 20 which may be opened or closed as desired by an actuator 22. The holding chamber 16 and the lock 18 are interconnected by a second internal gate valve 24 activated by an actuator 26. Access to the lock 18 from a workpiece loading and unloading area 19 is by an external gate valve 28 operable by an actuator 29. The gate valves and actuator may be of conventional design suitable for transferring workpieces of the desired size and shape. One such gate valve is shown in U.S. Patent 4,065,097 to Timin.

Each of the chambers of the processing apparatus is separately evacuable by conventional means. Lock 18 is evacuable by a blower or other 105 mechanical pump 32. For sputtering or electron beam heated coating processes, holding chamber 16 and the processing chamber 10 are preferably evacuable by diffusion pumps 30. Processing chamber 10 may be provided with a source 34 of a desired sputtering gas.

Each chamber of the vacuum processing apparatus is provided with a conveyor for supporting and transporting workpieces. For glass sheets and similar substrates, each conveyor 115 preferably comprises a series of parallel, horizontal rollers 42 mounted on a-frame 44 and driven by a reversible motor 46. Preferably the conveyors in the separate chambers are aligned to pass substrates into and out of the apparatus along a pass line 48.

120 In the preferred apparatus, the holding chamber 16 is provided with a plural-level transporting device 50 which moves vertically and which includes two horizontal conveyors 52 and 54 mounted one above the other on a common frame 60. As shown in 125 Figures 2, 3a and 3b, the frame 60 comprises two parallel upper longitudinal members 62, interconnected by a number of cross members 63, and two parallel lower longitudinal members 64, interconnected by a like number of cross members 65 aligned directly below the upper members. The

upper and lower members are connected by a number of uprights 66.

When frame 60 is in its lower position (shown in Figs. 2 and 3b) it rests on legs 68 which are
 5 adjustable as necessary to ensure that the frame rests level on the bottom wall 17 of holding chamber 16. Additional legs and additional cross members between the side members may be provided as
 10 necessary depending upon the length of the workpiece transporting device.

In Figures 2, 3a and 3b, the upper conveyor 52 of device 50 is aligned with the pass line 48. An elevator is provided in order to raise the frame 60 so that lower conveyor 54 is at the pass line. As shown,
 15 the elevator comprises four ball screw jacks 70 which extend externally of the chamber 16 through vacuum seal assemblies 71 in the bottom wall 17. Each jack is provided with an oiler 75 to lubricate the seal assembly. Alternatively, the elevator may
 20 comprise hydraulic or pneumatic cylinders.

Vertical motion of the transporting device 50 is guided by four lateral guide wheels 72, two of which are attached to the external face of each lower longitudinal member 64. The wheels roll along
 25 upper 73 and lower 74 bar ways mounted on opposite side walls of chamber 16. The motion of the device 50 is also guided by a longitudinal guide wheel 76 mounted on an axle 77 perpendicular to one of the lower longitudinal members 64. Wheel 76
 30 rolls between two upper ways 78 and two lower ways 79 mounted on one side wall 15 of chamber 16. The upper and lower ways for guide wheels 72 and 76 are aligned so that the device 50 is properly aligned in its raised and lowered positions,
 35 respectively.

A number of rollers 80 are mounted for rotation in bearing blocks 82 aligned along side rails 62 (the blocks 82 are omitted from Fig. 2). One end of the axle 83 of each roller is fitted with two pulleys 84
 40 and 85. As shown in Fig. 3a, corresponding pulleys of adjacent rollers are interconnected by belts 86 which ensure that the rollers turn simultaneously in the same direction.

The axle of one roller of whichever conveyor is at the pass line is coupled by a magnetic means 90, 92 to shaft 94 which extends through a rotary seal in side wall 15. The rotating shaft is driven by a reversible motor 95 outside chamber 16.

Figure 4 illustrates the method of the invention.
 50 Each part of the figure illustrates a processing chamber 100, a holding chamber 16 and a lock 18. The processing chamber may include entry and overrun buffers. Processing chamber 100 and holding chamber 16 are interconnected by a first
 55 gate valve 20. Processing chamber 16 and lock 18 are interconnected by a second gate valve 24. Workpiece access to lock 18 is provided by a third gate valve 28. Processing chamber 100 contains a first conveyor 101 and the lock 18 contains a second
 60 conveyor 102. As previously described, holding chamber 16 contains a workpiece transporting device 50 having two conveyors, upper level 52 and lower 54, and an elevator for aligning each conveyor with the pass line 48 through the vacuum
 65 processing apparatus.

In Figure 4a, valves 20 and 24 are closed. One workpiece 110 is undergoing processing in chamber 100 and an unprocessed workpiece 112 is waiting on the lower level 54 of the transporting device 50 in
 70 holding chamber 16. Since valves 20 and 24 are closed, chamber 16 may be evacuated by a diffusion pump and the pressure in the processing chamber 100 may be independently established, as desired. Valve 28 is open in order that a second unprocessed
 75 workpiece 114 may be transported from conveyor 104 in the loading and unloading area onto conveyor 102 inside the lock as illustrated in Fig. 4b. Valve 28 may then be closed and lock 18 evacuated by a roughing pump.

Transporting device 50 is aligned so that the vacant conveyor 52 is at the pass line. When processing of workpiece 110 is completed, valve 20 is opened and workpiece 110 is transported onto the vacant upper conveyor 52. The transporting device
 80 50 then moves upward so that the lower conveyor 54 is at the pass line, as shown in Fig. 4c, and the unprocessed workpiece 112 is transported onto the conveyor 101 in the processing chamber. Valve 20 is closed so that processing of workpiece 112 may
 85 proceed. Valves 24 and 28 remain closed so that pumping of lock 18 continues.

As illustrated in Fig. 4d, valve 24 is opened and unprocessed workpiece 114 is transported into holding chamber 16 onto the lower conveyor 54 of
 90 device 50. Then device 50 is moved down so that the upper conveyor 52 is aligned at the pass line, as shown in Fig. 4e, and processed workpiece 110 is transported through valve 24 onto conveyor 102 in lock 18, as shown in Fig. 4f. When this has been
 95 completed, valve 24 is closed. Valve 20 remains closed so that processing of workpiece 112 continues in chamber 100. Lock 18 is vented and gate valve 28 opened to enable the transfer of processed workpiece 110 out of lock 18 onto
 100 conveyor 104. Valves 24 and 20 are closed so that the pumping of holding chamber 16 and the processing in chamber 100 to continue. The processed workpiece 110 is unloaded from conveyor 104 and replaced with an unprocessed
 105 workpiece and the cycle continues, starting again with Fig. 4a.

Use of a holding chamber can reduce gas bursts into the processing chamber when gate 20 is opened and enables pumping of lock 16 except for the time required to transport workpieces through gate 28 as indicated in Figs. 4a and 4f. Efficient utilization of the processing equipment is ensured because processing may be continued except for the short time required to transfer workpieces
 110 between processing chamber 100 and holding chamber 16 as indicated in Figs. 4b and 4c.

As described in connection with Fig. 4, processed workpieces were placed on upper conveyor 52 and unprocessed workpieces were placed on lower
 115 conveyor 54. If falling debris is a problem, it may be preferable to modify the method so that processed workpieces are placed on the lower conveyor 54 below the unprocessed workpieces.

Various other modifications to the method and
 120 apparatus may be made without departing from the

spirit of the invention which is defined by the following claims.

5 CLAIMS

1. A vacuum processing apparatus comprising:
 first and second evacuable chambers;
 a first gate valve interconnecting the first and
 10 second chambers;
 a second gate valve for providing access to the
 second chamber;
 a first workpiece conveyor in the first
 chamber;
 15 a second workpiece conveyor outside the first
 and second chambers;
 a workpiece transporting device in the second
 chamber comprising
 third and fourth workpiece conveyors
 20 supported on a common frame;
 and means for selectively aligning the frame
 and each of the third and fourth conveyors to
 transfer workpieces between the first and
 second chambers when the first gate valve is
 25 open and between the second chamber and the
 second conveyor when the second gate valve is
 open.
2. A vacuum processing apparatus as claimed
 in claim 1, further comprising a third evacuable
 30 chamber and wherein the second gate valve
 interconnects the second and third chambers.
3. A vacuum processing apparatus as claimed
 in claim 1 or claim 2, wherein the third and
 fourth conveyors are parallel.
- 35 4. A vacuum processing apparatus as claimed
 in claim 3, wherein each conveyor comprises a
 number of parallel, substantially horizontal
 rollers and a means for simultaneously turning
 the rollers.
- 40 5. A vacuum processing apparatus as claimed
 in claim 4, wherein the third and fourth
 conveyors are supported one above the other,
 and the conveyor aligning means comprises an
 elevator for moving the frame in a vertical
 45 direction.
6. A processing apparatus as claimed in claim
 5, wherein the workpiece transporting device
 further comprises wheels mounted on the frame
 for guiding the movement of the frame.
- 50 7. A vacuum processing apparatus
 substantially as herein described with reference
 to the accompanying drawings.
8. A method for transporting workpieces into
 and out of a vacuum processing apparatus
 55 comprising:
 processing a workpiece;
 transporting the processed workpiece from a
 first conveyor in a first chamber to a first level
 of a multi-level conveyor in a second chamber;
 60 aligning the second level of the multi-level
 conveyor with the first conveyor;
 transporting a first unprocessed workpiece
 from the second level onto the first conveyor,
 then sealing the first chamber from the second
 65 chamber;
 transporting a second unprocessed workpiece
 from a second conveyor outside the second
 chamber onto the second level;
 aligning the first level with the second
 70 conveyor;
 transporting the processed workpiece from the
 first level to the second conveyor; and
 sealing the second chamber.
9. A method as claimed in claim 8, wherein
 75 the second conveyor is inside a third sealable
 chamber and further comprising:
 transporting each processed workpiece out of
 the apparatus from the second conveyor;
 transporting each unprocessed workpiece from
 80 outside the apparatus into the third chamber
 onto the second conveyor; and
 sealing and evacuating the third chamber.
10. A method for transporting workpieces into
 and out of a vacuum processing apparatus,
 85 substantially as herein described with reference
 to the accompanying drawings.