



- (51) International Patent Classification:
C12Q 1/68 (2006.01)
- (21) International Application Number:
PCT/US2013/025918
- (22) International Filing Date:
13 February 2013 (13.02.2013)
- (25) Filing Language: English
- (26) Publication Language: English
- (30) Priority Data:
61/598,240 13 February 2012 (13.02.2012) US
61/667,606 3 July 2012 (03.07.2012) US
- (71) Applicant: MOLECULAR SYSTEMS CORPORATION [US/US]; 1250 Eisenhower Pl., Ann Arbor, MI 48108 (US).
- (72) Inventors: WILLIAMS, Jeffrey; 1250 Eisenhower Pl., Ann Arbor, MI 48108 (US). BRAHMASANDRA, Sundaresh; 1250 Eisenhower Pl., Ann Arbor, MI 48108 (US). KUSNER, Michael, T.; 1250 Eisenhower Pl., Ann Arbor, MI 48108 (US).
- (74) Agent: SCHOX, Jeffrey; 500 3rd Street, Ste. 515, San Francisco, CA 94107 (US).

- (81) Designated States (unless otherwise indicated, for every kind of national protection available): AE, AG, AL, AM, AO, AT, AU, AZ, BA, BB, BG, BH, BN, BR, BW, BY, BZ, CA, CH, CL, CN, CO, CR, CU, CZ, DE, DK, DM, DO, DZ, EC, EE, EG, ES, FI, GB, GD, GE, GH, GM, GT, HN, HR, HU, ID, IL, IN, IS, JP, KE, KG, KM, KN, KP, KR, KZ, LA, LC, LK, LR, LS, LT, LU, LY, MA, MD, ME, MG, MK, MN, MW, MX, MY, MZ, NA, NG, NI, NO, NZ, OM, PA, PE, PG, PH, PL, PT, QA, RO, RS, RU, RW, SC, SD, SE, SG, SK, SL, SM, ST, SV, SY, TH, TJ, TM, TN, TR, TT, TZ, UA, UG, US, UZ, VC, VN, ZA, ZM, ZW.
- (84) Designated States (unless otherwise indicated, for every kind of regional protection available): ARIPO (BW, GH, GM, KE, LR, LS, MW, MZ, NA, RW, SD, SL, SZ, TZ, UG, ZM, ZW), Eurasian (AM, AZ, BY, KG, KZ, RU, TJ, TM), European (AL, AT, BE, BG, CH, CY, CZ, DE, DK, EE, ES, FI, FR, GB, GR, HR, HU, IE, IS, IT, LT, LU, LV, MC, MK, MT, NL, NO, PL, PT, RO, RS, SE, SI, SK, SM, TR), OAPI (BF, BJ, CF, CG, CI, CM, GA, GN, GQ, GW, ML, MR, NE, SN, TD, TG).

Published:

- with international search report (Art. 21(3))
- with amended claims (Art. 19(1))

(54) Title: SYSTEM AND METHOD FOR PROCESSING AND DETECTING NUCLEIC ACIDS

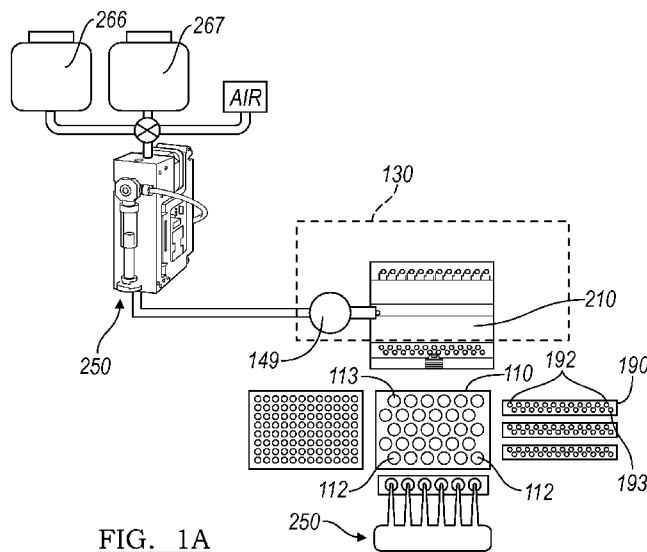

FIG. 1A

(57) Abstract: A system and method for processing and detecting nucleic acids from a set of biological samples, comprising: a capture plate and a capture plate module configured to facilitate binding of nucleic acids within the set of biological samples to magnetic beads; a molecular diagnostic module configured to receive nucleic acids bound to magnetic beads, isolate nucleic acids, and analyze nucleic acids, comprising a cartridge receiving module, a heating/cooling subsystem and a magnet configured to facilitate isolation of nucleic acids, a valve actuation subsystem configured to control fluid flow through a microfluidic cartridge for processing nucleic acids, and an optical subsystem for analysis of nucleic acids; a fluid handling system configured to deliver samples and reagents to components of the system to facilitate molecular diagnostic protocols; and an assay strip configured to combine nucleic acid samples with molecular diagnostic reagents for analysis of nucleic acids.



SYSTEM AND METHOD FOR PROCESSING AND DETECTING NUCLEIC ACIDS

TECHNICAL FIELD

[0001] This invention relates generally to the molecular diagnostics field, and more specifically to an improved system and method for processing and detecting nucleic acids.

BACKGROUND

[0002] Molecular diagnostics is a clinical laboratory discipline that has developed rapidly during the last 25 years. It originated from basic biochemistry and molecular biology research procedures, but now has become an independent discipline focused on routine analysis of nucleic acids (NA), including deoxyribonucleic acid (DNA) and ribonucleic acid (RNA) for diagnostic use in healthcare and other fields involving analysis of nucleic acids. Molecular diagnostic analysis of biological samples can include the detection of one or more nucleic acid materials present in the specimen. The particular analysis performed may be qualitative and/or quantitative. Methods of analysis typically involve isolation, purification, and amplification of nucleic acid materials, and polymerase chain reaction (PCR) is a common technique used to amplify nucleic acids. Often, a nucleic acid sample to be analyzed is obtained in insufficient quantity, quality, and/or purity, hindering a robust implementation of a diagnostic technique. Current sample processing methods and molecular diagnostic techniques are often labor/time intensive, low throughput, and expensive, and systems of analysis are insufficient. Furthermore, methods of isolation, processing, and amplification are specific to certain sample matrices and/or nucleic acid types and not applicable across common sample and nucleic acid types.

[0003] Due to these and other deficiencies of current molecular diagnostic systems and methods, there is thus a need for an improved system and method for processing and detecting nucleic acids. This invention provides such a system and method.

BRIEF DESCRIPTION OF THE FIGURES

- [0004]** FIGURES 1A-1B depict an embodiment of a system for processing and detecting nucleic acids;
- [0005]** FIGURES 2A-2B depict an embodiment of elements, and a top view of an embodiment of a system worktable, respectively, of an embodiment of a system for processing and detecting nucleic acids;
- [0006]** FIGURES 3A-3B depict an embodiment of a capture plate for combining a sample with magnetic beads;
- [0007]** FIGURE 4 depicts an embodiment of a capture plate module to facilitate lysis of a biological sample and combination of the biological sample with magnetic beads;
- [0008]** FIGURES 5A-5B depict an alternative embodiment of a capture plate;
- [0009]** FIGURES 6A-6B depict embodiments of a molecular diagnostic module for processing and detecting nucleic acids;
- [0010]** FIGURES 7A-7E depict a sequence of operations performed by elements of an embodiment of a molecular diagnostic module;
- [0011]** FIGURE 8 depicts an embodiment of a microfluidic cartridge and an embodiment of a cartridge platform;
- [0012]** FIGURES 9A-9B depict configurations of a linear actuator of an embodiment of a molecular diagnostic module;
- [0013]** FIGURES 10A-10B depict elements of an embodiment of a valve actuation subsystem of a molecular diagnostic module;
- [0014]** FIGURES 11A-11C depict an embodiment of a valve actuation subsystem of a molecular diagnostic module;
- [0015]** FIGURES 12A-12D depict elements of an embodiment of an optical subsystem of a molecular diagnostic module;
- [0016]** FIGURE 13 depicts a side view of an alternative embodiment of a molecular diagnostic module for processing and detecting nucleic acids;
- [0017]** FIGURES 14A-14C depict an embodiment of a fluid handling system of a system for processing and detecting nucleic acids;
- [0018]** FIGURE 15 depicts embodiments of elements of the fluid handling system;

- [0019] FIGURES 16A-16C are schematics depicting example methods for processing and detecting nucleic acids;
- [0020] FIGURES 17A-17B show embodiments of consumables and reagents used in a system for processing and detecting nucleic acids;
- [0021] FIGURES 18A-18B depict an embodiment of an assay strip to facilitate analysis of a sample containing nucleic acids;
- [0022] FIGURE 19 depicts an embodiment of an assay strip holder;
- [0023] FIGURE 20 depicts an embodiment of an assay strip carrier;
- [0024] FIGURES 21A-21B show alternative embodiments of assay strip holders and assay strips, respectively;
- [0025] FIGURE 22 shows an embodiment of a filter to facilitate processing and detecting of nucleic acids;
- [0026] FIGURE 23 shows an embodiment of a filter holder to facilitate processing and detecting of nucleic acids; and
- [0027] FIGURES 24A-24D depict embodiments of a method for processing and detecting nucleic acids.

DESCRIPTION OF THE PREFERRED EMBODIMENTS

[0028] The following description of preferred embodiments of the invention is not intended to limit the invention to these preferred embodiments, but rather to enable any person skilled in the art to make and use this invention.

1. System for Processing and Detecting Nucleic Acids

[0029] As shown in FIGURES 1A-1B and 7A, an embodiment of a system 100 for processing and detecting nucleic acids comprises: a capture plate 110 configured to facilitate binding of nucleic acids within a biological sample to a set of magnetic beads 119; a molecular diagnostic module 130 comprising a microfluidic cartridge receiving module 140, heating and cooling subsystem 150, a magnet 160, a valve actuation subsystem 170, an optical subsystem 180; and an assay strip 190 configured to facilitate mixing of molecular diagnostic reagents with a nucleic acid volume. Other embodiments of the system 100 may further comprise at least one of a capture plate module 120 configured to support the capture plate 110; a filter 200 and filter holder 205 to facilitate sample preparation; a microfluidic cartridge 210 configured to facilitate sample processing; an assay strip holder 230; an assay strip

carrier 240; a liquid handling system 250 configured to facilitate gas and fluid delivery to different elements of the system 100; a processor configured to analyze data resulting from a run of the system 100; and a user interface configured to allow a user to interact with the system 100. The system 100 thus functions to receive biological samples containing nucleic acids (i.e., impure nucleic acid samples), separate nucleic acids from the biological samples, and analyze nucleic acid samples according to at least one molecular diagnostic protocol (e.g., PCR). Preferably, the system 100 is a walkaway system by which a user loads a set of biological samples containing nucleic acids, and receives a set of data resulting from a molecular diagnostic protocol without any further sample manipulation by the user. Alternatively, the system 100 facilitates aspects of sample preparation for a molecular diagnostic protocol, with some sample manipulation performed by the user.

[0030] In one example workflow of the system 100, a liquid handling system 250 aspirates a set of biological samples containing nucleic acids (i.e., impure nucleic acid samples), and dispenses the set of biological samples into a capture plate 110 to be lysed and combined with magnetic beads (containing a proprietary affinity coating to bind the nucleic acids to the magnetic beads) by a capture plate module 120. The liquid handling system 250 then aspirates substantially all of each sample of the set of lysed biological samples combined with magnetic beads (i.e., set of magnetic bead-samples) from the capture plate 110, and dispenses the set of magnetic bead-samples into a microfluidic cartridge 210, aligned within a cartridge receiving module 140 of a molecular diagnostic module 130, and configured to be manipulated by the molecular diagnostic module 130. A heating and cooling subsystem 150, a magnet 160, and a valve actuation subsystem 170 of the molecular diagnostic module 130 then facilitate separation of a set of nucleic acids from the magnetic bead-samples, as the liquid handling system 250 dispenses wash solutions, release solutions, and/or air at appropriate stages. The liquid handling system 250 then aspirates the set of nucleic acids from the microfluidic cartridge 210 contained within the molecular diagnostic module 130, combines the set of nucleic acids with a set of molecular diagnostic reagents using an assay strip 190, and dispenses the set of nucleic acids combined with the set of molecular diagnostic reagents (i.e., set of nucleic acid-reagent mixtures) into the microfluidic cartridge 210 within the

molecular diagnostic module 130. The detection chamber heaters 157, optical subsystem 180 and valve actuation subsystem 170 of the molecular diagnostic module 130 then facilitate analysis of the set of nucleic acid-reagent mixtures by a processor configured to display information on a user interface.

[0031] As stated, the above workflow is just one example workflow of the system 100, and other workflows of the system 100 and methods of processing and detecting nucleic acid samples are further described in Section 2 below. A detailed description of elements of an embodiment of the system 100 are described in sections 1.1-1.6 below.

1.1 System – Capture Plate and Capture Plate Module

[0032] As shown in FIGURES 3A and 3B, the capture plate 110 comprises a capture plate substrate 111 comprising a set of wells 112 and a puncturable foil seal 115, and functions to facilitate binding of nucleic acids within a biological sample to a set of magnetic beads 119. Preferably, the entire capture plate 110 is configured to be a consumable (i.e., disposable), such that each well of the capture plate 110 can only be used once yet the remaining unused wells can be used during additional runs of the system 100. Alternatively, at least a portion of the capture plate 110 is configured to be reusable, such that additional mixing or reagent additions can be performed and portions of the capture plate 110 may be used for multiple runs of the system 100. In one variation of the capture plate 110, the capture plate substrate 111 is reusable, while the puncturable foil seal 115 is disposable and replaced after each run of the system 100.

[0033] The capture plate substrate 111 is configured such that the capture plate 110 is capable of resting on a flat surface, can be stacked with another capture plate 110, and also can be manipulated with industry standard instrument components for handling of microtiter plates. The capture plate substrate also functions to define the set of wells 112 and to couple to the puncturable foil seal 115. The capture plate substrate 111 is preferably composed of a PCR-compatible polymer that can be heat processed to couple to the puncturable foil seal 115, but can alternatively be composed of any appropriate material that can contain a fluid and be bonded to the puncturable foil seal 115.

[0034] The set of wells 112 of the capture plate substrate 111 function to receive at least one biological sample which contain or are suspected of potentially

containing nucleic acids, and to facilitate combination of the biological sample with a set of magnetic beads 119. Preferably, the wells 113 are each configured to accommodate not only a biological sample, but also to facilitate mixing of the biological sample with a set of magnetic beads 119 (e.g., using a pipettor, the liquid handling system 250 or other apparatus), which preferably are preloaded in wells 112, or alternatively may be added by an operator. Preferably, the wells are also deeper than they are wide to allow a significant number of wells 112 (e.g. 24) with a clinically relevant sample volumes, and evenly spaced to facilitate aspiration, delivery, and/or mixing of multiple biological samples (e.g., with a multi-tip pipettor). Alternatively, the wells are wider than they are deep to facilitate larger devices for mixing the biological samples with the magnetic beads 119. Each well 113 of the set of wells 112 also preferably has a conically shaped bottom region, as shown in FIGURE 3A, to facilitate complete aspiration of a fluid from a well. Alternatively, each well 113 may not have a conically shaped bottom region. Additionally, in the orientation shown in FIGURE 3A, the tops of each well 113 in the set of wells 112 preferably form raised edges protruding from the capture plate substrate 111, in order to facilitate sealing of each well 113 by the puncturable foil seal 115. Alternatively, the tops of each well 113 in the set of wells 112 may not form raised edges protruding from the capture plate substrate 111. The magnetic beads are preferably polymer beads, precoupled with a ligand for binding to a nucleic acid, and comprising a superparamagnetic component. Additionally, the magnetic beads may be treated to be positively charged. However, the magnetic beads may alternatively be any appropriate magnetic beads (e.g. magnetic, paramagnetic, or superparamagnetic) configured to facilitate biomagnetic separation.

[0035] Each quantity of magnetic beads 119 may be accompanied by lysing reagents (e.g. proteinase K) and a sample process control comprising nucleic acid sequences for DNA and RNA, which function to lyse biological samples and to provide a mechanism by which sample process controls may be later detected to verify processing fidelity and assay accuracy. The sample process control comprising nucleic acid sequences for DNA and RNA allows one version of the capture plate to facilitate assays involving DNA and RNA detection. Preferably, the quantity of magnetic beads 119, lysing reagents, and sample process controls is dried within each

well to improve shelf life; however, the quantity of magnetic beads 119, lysing reagents, and sample process controls may alternatively be in liquid form.

[0036] The puncturable foil seal 115 functions to isolate each well 113 of the set of wells 112, prevent contamination of the contents of each of the set of wells 112, protect the magnetic beads 119 and other reagents stored in wells 112 from degradation, and provide information identifying the capture plate 110. The puncturable foil seal 115 preferably seals each well 113 of the capture plate 110, and is configured to be punctured by an external element (e.g., by a pipette tip), such that each well is sealed prior to being punctured. In one variation, the puncturable foil seal 115 also forms a seal around an element that punctures it, and in another variation, the puncturable foil seal 115 does not form a seal around an element that punctures it, in order to prevent airlock. The puncturable foil seal 115 is also preferably labeled with identifying information including at least one of manufacturer information, capture plate contents, the lot of the contents, an expiry date, and a unique electronic tag (e.g., barcode or QR code) providing more information. Preferably, the puncturable foil seal 115 does not extend beyond the footprint of the capture plate 110, but alternatively, the puncturable foil seal 115 may be any appropriate size and/or include protruding features (e.g., tabs) that facilitate handling of the capture plate.

[0037] In one variation, the capture plate 110 may be prepackaged at least with magnetic beads 119, such that each well 113 in the set of wells 112 is prepackaged with a set of magnetic beads 119 defined by a specific quantity or concentration of magnetic beads. The set of wells 112 may then be sealed by the puncturable foil seal 115, which is configured to be punctured by an external element that delivers volumes of biological samples to be mixed with the magnetic beads 119. In another variation, the capture plate 110 may not be prepackaged with magnetic beads 119, but the wells 113 of the capture plate may still be sealed with a puncturable foil seal 115. In this variation, the puncturable foil seal 115 is configured to be punctured by at least one external element, for co-delivery of biological samples and magnetic beads intended to be combined.

[0038] A variation of the capture plate 110' may further comprise a slotted rubber membrane 116, as shown in FIGURES 5A and 5B, configured to provide access through the puncturable foil seal 115 to the set of wells 112. The slotted rubber

membrane 116 thus functions to prevent or reduce splashing, evaporation, and/or aerosolization of contents of the set of wells 112. Preferably, the slotted rubber membrane 116 comprises slots that are self-sealing and centered over wells of the set of wells 112, and further does not extend beyond the footprint of the capture plate 110. Alternatively, the slots of the slotted rubber membrane 116 may not be self-sealing, and/or the slotted rubber membrane 116 may be any appropriate size and comprise features that extend beyond the footprint of the capture plate 110.

[0039] In a specific example, the capture plate 110 comprises 24 wells 113 with an 18mm center-to-center pitch, each well having a volumetric capacity of 2mL, and is compliant with Society for Laboratory Automation and Screening (SLAS) standards. Each well 113 of the capture plate 110 in the specific example is also prepackaged with a specified quantity of magnetic beads 119, and comprises a protruding top edge that is heat sealed to a puncturable foil seal. In addition, each well 113 also contains other reagents beneficial for processing and monitoring the sample, including proteinase K and one or more specific nucleic acid stands designed to serve as a process control. The specific example of the capture plate 110 can thus combine two groups of 12 biological samples with magnetic beads. The capture plate 110 in the specific example is produced by injection molding, has a footprint of 127.75mm x 85.5mm, and is composed of a PCR-compatible polypropylene based polymer with a high vapor barrier.

[0040] An embodiment of the system 100 may further comprise a capture plate module 120, as shown in FIGURE 4, which functions to receive, support, and heat a capture plate 110. The capture plate module 120 preferably comprises a thermally conducting substrate 121 configured to cradle a capture plate 110, a capture plate heater 123, a capture plate receiving module 125, and a capture plate electronics module 127. Preferably, the capture plate module 120 functions to facilitate lysis of a biological sample deposited into a well 113 of the capture plate, and to facilitate binding of nucleic acids (i.e., within a lysed biological sample) to a quantity of magnetic beads 119 within a well 113 of the capture plate 110. In a specific example, the capture plate module 120 has dimensions of 108mm x 156mm x 45mm and is configured to rest on a flat surface.

[0041] The thermally conducting substrate 121 is configured to cradle and support the capture plate 110, and functions to conduct heat to the set of wells 112 of

the capture plate 110. Preferably, the thermally conducting substrate 121 is also configured to reversibly couple to the capture plate 110, and comprises a set of indentations 122 that encircle each well 113 in the set of wells 112. In one variation, the indentations 122 completely conform to the external surface of each well 113 of the capture plate 110, but in another variation, the indentations 122 may encircle a portion of each well 113 of the capture plate 110. Additionally, the indentations 122 are preferably thermally conducting in order to conduct heat to the set of wells 112, and portions of the thermally conducting substrate 121 aside from the indentations 122 are composed of non-conducting, rigid material. Alternatively, the entire thermally conducting substrate 121 may be composed of a material that is thermally conducting.

[0042] The capture plate heater 123 is preferably coupled to the thermally conducting substrate 121, and functions to transfer heat, through the thermally conducting substrate 121, to a well 113 of the capture plate 110. The capture plate heater 123 preferably conforms to at least a portion of an indentation 122 of the thermally conducting substrate 121, to facilitate heat transfer through the indentation 122 to an individual well 113 of the capture plate 110. In this variation, the capture plate heater 123 is one of a set of capture plate heaters 124, wherein each capture plate heater 123 in the set of capture plate heaters 124 transfers heat to an individual well 113 of the set of wells 112 of the capture plate 110. Alternatively, the capture plate heater 123 may conform to portions of multiple indentations 122 of the thermally conducting substrate 121, such that the capture plate heater 123 is configured to transfer heat to multiple wells 113 of the capture plate 110. Preferably, the capture plate heater 123 is a resistance heater, but alternatively, the capture plate heater 123 may be a Peltier or any appropriate heater configured to transfer heat to the capture plate 110. The capture plate heater 123 may also further couple to a heat sink.

[0043] The capture plate receiving module 125 comprises a capture plate actuation system 126 that functions to couple the capture plate module 120 to a capture plate 110. As shown in FIGURE 4, the capture plate actuation system 126 comprises a structural support with hinged grips 128 and at least one capture plate module actuator 129. The capture plate module actuator 129 is preferably a push-type solenoid with a spring return, but may alternatively be any appropriate linear

actuator, such as a hydraulic actuator. The structural support with hinged grips 128 preferably couples to the capture plate heater 123 and houses the capture plate module actuator 129, such that, in a first configuration, actuation of the capture plate module actuator 129 outwardly displaces the hinged grips (allowing the capture plate module 120 to receive a capture plate 110), and in a second configuration, actuation of the capture plate module actuator 129 inwardly displaces the hinged grips (allowing the capture plate module 120 to couple to the capture plate 110). The structural support with hinged grips 128 may further comprise a textured and/or high-friction surface configured to grip a capture plate 110, but alternatively may not comprise a textured and/or high-friction surface.

[0044] The capture plate electronics module 127 is coupled to the capture plate heater 123 and the capture plate actuation system 126, and functions to enable control of the capture plate heater 123 and the capture plate actuation system 126. Preferably, the capture plate electronics module 127 modulates an output of the capture plate heater 123, in order to controllably heat at least one well 113 of the capture plate 110. Additionally, the capture plate electronics module 127 preferably modulates the capture plate actuation system 126, in order to controllably couple the capture plate module 120 to a capture plate 110. Preferably, the capture plate electronics module 127 is coupled to an external power supply, such that the capture plate module 120 does not include an integrated power supply; however, in alternative embodiments, the capture plate electronics module 127 may be coupled to a power supply integrated with the capture plate module 120.

1.2 System – Molecular Diagnostic Module

[0045] As shown in FIGURES 6A and 6B, an embodiment of the molecular diagnostic module 130 of the system 100 includes a cartridge receiving module 140, a heating and cooling subsystem 150, a magnet 160, a valve actuation subsystem 170, and an optical subsystem 180, and functions to manipulate a microfluidic cartridge 210 for processing of a biological sample containing nucleic acids. The molecular diagnostic module 130 is preferably configured to operate in parallel with at least one other molecular diagnostic module 130, such that multiple microfluidic cartridges 210 containing biological samples may be processed simultaneously. In a first variation, the molecular diagnostic module 130 is configured to be stackable with another molecular diagnostic module 130 in a manner that enables access to a

microfluidic cartridge 210 within each molecular diagnostic module 130; an example of the first variation is shown in FIGURE 6B, where the molecular diagnostic modules 130 are stacked in a staggered configuration. In the first variation, each molecular diagnostic module 130 may further comprise locking pins or other appropriate mechanisms to couple the stacked molecular diagnostic modules 130 together. In another variation, the molecular diagnostic module 130 may not be configured to stack with another molecular diagnostic module, such that the molecular diagnostic modules 130 are configured to rest side-by-side on the same plane. Elements of an embodiment of the molecular diagnostic module 130 are further described in sections 1.2.1 to 1.2.5 below.

1.2.1 Molecular Diagnostic Module – Cartridge Receiving Module

[0046] As shown in FIGURE 9A, the cartridge receiving module 140 of the molecular diagnostic module 130 comprises a cartridge platform 141 including a cartridge loading guiderail 142, a cartridge stop 143, a magnet receiving slot 144, and a set of valve actuation slots 145; a linear actuator 146 configured to displace a microfluidic cartridge 210 resting on the cartridge platform 141; and a set of springs 148 coupled to the cartridge platform 141. The cartridge receiving module 140 thus functions to receive, align, and compress a microfluidic cartridge 210 for processing of a biological sample according to a molecular diagnostic assay protocol. As shown in FIGURES 7A-7C, the cartridge platform 141 is preferably configured to receive a microfluidic cartridge 210 along a cartridge loading guiderail 142 until it reaches a cartridge stop 143, and be vertically displaced by the linear actuator 146, which places a biasing force against the set of springs 148 coupled to the cartridge platform 141. The magnet receiving slot 144 and the set of valve actuation slots 145 provide access, by a magnet 160 and a valve actuation subsystem 170, to the microfluidic cartridge 210, as the microfluidic cartridge is vertically displaced by the linear actuator 146.

[0047] The cartridge platform 141 includes a cartridge loading guiderail 142, a cartridge stop 143, a magnet receiving slot 144, and a set of valve actuation slots 145, and functions to receive and align a microfluidic cartridge 210, while providing access to the microfluidic cartridge 210 by a magnet 160 and a valve actuation subsystem 170. As shown in FIGURE 8, an embodiment of the cartridge platform 141 includes a pair of parallel cartridge loading guiderails 142, initiating at a pair of

inwardly tapering protrusions configured to guide a microfluidic cartridge toward the pair of parallel cartridge loading guiderails 142, and spanning two short edges of the cartridge platform 141. The embodiment of the cartridge platform 141 also includes a cartridge stop 143 comprising a vertical tab oriented perpendicular to the cartridge loading guiderails 142, and spanning a long edge of the cartridge platform. Preferably, the cartridge loading guiderails 142 and the cartridge stop 143 are configured such that a microfluidic cartridge 210 slides between the cartridge loading guiderails 142 and hits the cartridge stop 143 to signal proper alignment. Alternatively, the cartridge loading guiderails 142 and the cartridge stop 143 may be configured such that a microfluidic cartridge slides over or along the cartridge loading guiderails 142, after which the cartridge stop 143 couples to a portion of the microfluidic cartridge 210 to ensure proper alignment of the microfluidic cartridge. Additional variations of the cartridge loading guiderails 142 and the cartridge stop 143 may be used to enable reception and alignment of a microfluidic cartridge 210 by the molecular diagnostic module 130, and are known by those skilled in the art.

[0048] The embodiment of the cartridge platform 141 shown in FIGURE 8 also includes a set of valve actuation slots 145, oriented perpendicular to the parallel cartridge loading guiderails 142 and configured to provide access to a valve actuation subsystem 170, and a magnet receiving slot 144 located among the set of valve actuation slots 145. Preferably, the magnet receiving slot 144 and the set of valve actuation slots 145 substantially span a long dimension of the cartridge platform 141, as shown in FIGURE 8, and are configured to correspond to locations on a microfluidic cartridge 210 requiring a magnetic field and/or valving to enable processing of a biological sample and nucleic acid detection once the microfluidic cartridge 210 has been aligned within the molecular diagnostic module 130. Thus, alternative configurations of the magnet receiving slot 144 and the set of valve actuation slots 145 may accommodate other cartridges with alternative regions requiring magnetic fields and/or valving to enable other protocols. In one alternative embodiment, the magnet receiving slot 144 and the set of valve actuation slots may comprise one continuous void of the cartridge platform 141, such that the cartridge platform 141 supports a microfluidic cartridge 210 along the periphery of the microfluidic cartridge 210, but forms a continuous void under a majority of the footprint of the microfluidic cartridge 210.

[0049] The linear actuator 146 functions to linearly displace a microfluidic cartridge 210 resting on the cartridge platform 141, in order to compress the microfluidic cartridge 210 and position the microfluidic cartridge 210 between a cartridge heater 153 and an optical subsystem 180 on one side of the microfluidic cartridge 210, and a magnet 160 and detection chamber heaters 157 on another side of the microfluidic cartridge 210. The linear actuator 146 also functions to provide a sufficient counterforce to the valve actuation subsystem 170 such that a microfluidic cartridge 210 within the molecular diagnostic module 130 remains properly situated upon manipulation by the valve actuation subsystem 170. The linear actuator 146 further functions to move a nozzle 149 coupled to the liquid handling system 250, in order to couple the liquid handling system 250 to a fluid port 222 of the microfluidic cartridge 210. In the orientation of the molecular diagnostic module 130 shown in FIGURES 7B and 7B, the linear actuator 146 is preferably coupled to a portion of the heating and cooling subsystem 150 a portion of the optical subsystem 180, and the nozzle 149, and vertically displaces the cartridge heater 153, the optical subsystem 180, and the nozzle 149 to position the cartridge heater 153, 180 and the nozzle 149 over the microfluidic cartridge 210. The vertical displacement also allows the microfluidic cartridge 210 to receive a magnet 160, which provides a magnetic field to facilitate a subset of a molecular diagnostic protocol, and detection chamber heaters 157, which allows amplification of nucleic acids for molecular diagnostic protocols requiring heating and cooling of the nucleic acid (e.g. PCR). Preferably, the linear actuator 146 is a scissor jack actuator configured to apply substantially uniform pressure over all occlusion positions of a microfluidic cartridge 210 aligned within the molecular diagnostic module 130, and to operate in at least two configurations. In a retracted configuration 146a, as shown in FIGURE 9A, the scissor jack actuator has not linearly displaced the cartridge platform 141, and in an extended configuration 146b, as shown in FIGURE 9B, the scissor jack actuator has linearly displaced the microfluidic cartridge 210 to position the microfluidic cartridge 210 between the subsystems 153, and 180, and the magnet 160 and detection chamber heaters 157. Additionally, the extended configuration 146b of the scissor jack actuator is configured to couple the nozzle 149 to a fluid port 222 of the microfluidic cartridge 210, such that the liquid handling system 250 can deliver solutions and gases for processing of biological samples. The linear actuator 146 may

alternatively be any appropriate linear actuator, such as a hydraulic, pneumatic, or motor-driven linear actuator, configured to linearly displace a microfluidic cartridge within the molecular diagnostic module 130.

[0050] As shown in FIGURES 7B, 7C, and 8, a set of springs 148 is coupled to the cartridge platform 141 and functions to provide a counteracting force against the linear actuator 146 as the linear actuator 146 displaces a microfluidic cartridge 210 resting on the cartridge platform 141. The set of springs 148 thus allows the cartridge platform 141 to return to a position that allows the microfluidic cartridge 210 to be loaded and unloaded from the molecular diagnostic module 130 when the linear actuator 146 is in a retracted configuration 146b, as shown in FIGURE 7B. Preferably, in the orientation shown in FIGURE 7B, the set of springs 148 is located at peripheral regions of the bottom side of the cartridge platform 141, such that the set of springs 148 does not interfere with the magnet or the valve actuation subsystem 170. Alternatively, the set of springs 148 may be located at any appropriate position to provide a counteracting force against the linear actuator 146. In a specific example shown in FIGURE 6A, the set of springs 148 comprises four springs located near corners of the bottom side of the cartridge platform 141, but in other variations, the set of springs 148 may comprise any appropriate number of springs. Each spring of the set of springs 148 is also preferably housed within a guide to prevent deviations from linear vertical motions (in the orientation shown in FIGURE 7B); however, each spring in the set of springs 148 may alternatively not be housed within a guide. In an alternative embodiment of the molecular diagnostic module 130, the set of springs 148 may altogether be replaced by a second linear actuator configured to linearly displace a microfluidic cartridge 210, resting on the cartridge platform 141, in a direction opposite to the displacements enforced by the linear actuator 146.

[0051] Similarly, the nozzle 149, the heating and cooling subsystem 150, the cartridge heater 153, and the magnet 160 are preferably coupled to springs, such that springs are positioned between elements 149, 150, 153, and 160, and substrates that elements 149, 150, 153, and 160 are mounted to. Alternatively an elastomeric material is preferably positioned between elements 149, 150, 153, and 160, and substrates that elements 149, 150, 153, and 160 are mounted to. The springs and/or elastomeric material function to provide proper functioning and alignment of

subsystems of the molecular diagnostic module 130 as the linear actuator 146 is extended or retracted, contributing to reliability and a reduction in stack up tolerance risk. The springs and/or elastomeric material further function to allow more pressure to be applied to occlusion positions of a microfluidic cartridge 210 aligned within the molecular diagnostic module 130, and an appropriate pressure to be applied to elements 149, 150, 153 and 160 of the molecular diagnostic module 130. Thus, proper contact is maintained between elements 149, 150, 153, and 160, and a microfluidic cartridge 210 being manipulated by the molecular diagnostic module. These elements are described in further detail below.

1.2.2 Molecular diagnostic module – Heating/Cooling Subsystem and Magnet

[0052] The heating and cooling subsystem 150 of the molecular diagnostic module 130 comprises a cartridge heater 153, a fan 155, and a set of detection chamber heaters 157 and functions to controllably heat portions of a microfluidic cartridge 210 for processing of a biological sample containing nucleic acids according to a molecular diagnostic protocol. In the orientation of an embodiment of the molecular diagnostic module 130 shown in FIGURES 7A-7C, the cartridge heater 153 is preferably coupled to the linear actuator 146 of the cartridge receiving module 140 and configured to span a central region of a microfluidic cartridge 210 aligned within the molecular diagnostic module 130, the fan 155 is located at a back wall of the cartridge receiving module 140, and the set of detection chamber heaters 157 is located inferior to a set of detection chambers 213 of the microfluidic cartridge 210. In alternative embodiments of the molecular diagnostic module 130, the heating and cooling subsystem 150 may have any appropriate alternative configuration that provides controlled heating and cooling to a microfluidic cartridge within the molecular diagnostic module 130.

[0053] The cartridge heater 153 functions to transfer heat to a heating region 224 of a microfluidic cartridge 210, for inducing a pH shift to release bound nucleic acids from magnetic beads within the heating region 224. The cartridge heater 153 is preferably a plate-shaped heater configured to transfer heat to the microfluidic cartridge 210 only from one side of the cartridge heater 153, such that heat flows through one face of the plate-shaped heater to the microfluidic cartridge 210. In a specific example, the cartridge heater 153 is a silicon wafer etched to be conductive

and form a resistance heater. In the preferred variation, the cartridge heater 153 is either flip-chip bonded (i.e., soldered to back side of a circuit board), or wire bonded to a circuit board, and then coupled using linear bearings and springs to a plate coupled to the linear actuator 146. The preferred variation allows independent control of 12 independent channels, corresponding to 12 different pathways for sample processing. In another variation, heating through one face is accomplished using a plate-shaped resistance heater that has one exposed face and thermal insulation covering all other faces, and in yet another variation heating through one face is accomplished using a Peltier heater. In a variation of the cartridge heater 153 using a Peltier heater, the cartridge heater 153 comprises a thermoelectric material, and produces different temperatures on opposite faces of the cartridge heater 153 in response to a voltage difference placed across the thermoelectric material. Thus, when a current flows through the Peltier heater, one face of the Peltier heater lowers in temperature, and another face of the Peltier heater increases in temperature. Alternative variations of the cartridge heater 153 can be used to appropriately transfer heat to a heating region 224 of the microfluidic cartridge 210.

[0054] Preferably, the cartridge heater 153 is configured to linearly translate with the linear actuator 146 of the cartridge receiving module 140, in order to align with a heating region 224 spanning a central portion of a microfluidic cartridge 210 aligned within the molecular diagnostic module 130. In one variation, the cartridge heater 153 is preferably fixed relative to the linear actuator 146 such that (in the orientation shown in FIGURES 7B-7C), the cartridge heater 153 can only move vertically with the linear actuator. In an alternative variation, the cartridge heater 153 may additionally be configured to translate laterally with a horizontal plane (in the orientation shown in FIGURES 7B-7C), such that the cartridge heater 153 can translate in at least two perpendicular coordinate planes. In this alternative variation, the cartridge heater 153 can be configured to sweep across a surface of a microfluidic cartridge 210 aligned within the molecular diagnostic module 130, or to translate in response to motion of the microfluidic cartridge 210, such that the position of the cartridge heater 153 relative to a heating region 224 of the microfluidic cartridge 210 is always fixed.

[0055] The fan 155 functions to modulate heat control within the molecular diagnostic module 130, by enabling heat transfer from warm objects within the

molecular diagnostic module 130 to cooler air external to the molecular diagnostic module 130. In the orientation shown in FIGURE 6A, the fan 155 is preferably located at a back face of the molecular diagnostic module 130, such heat within the molecular diagnostic module 130 is transferred out of the back face of the molecular diagnostic module 130 to cooler air external to the molecular diagnostic module. In a specific embodiment, the molecular diagnostic module 130 comprises four fans 155 located at the back face of the molecular diagnostic module 130; however, in alternative embodiments the molecular diagnostic module 130 may comprise any appropriate number of fans located at any appropriate position of the molecular diagnostic module 130. In one variation, the fan 155 may be passive and driven solely by convection currents resulting from motion of hot air within the molecular diagnostic module to cooler air outside of the molecular diagnostic module; however, in alternative variations, the fan 155 may be motor-driven and configured to actively cool internal components of the molecular diagnostic module 130 if molecular diagnostic module elements exceed a certain threshold temperature.

[0056] The set of detection chamber heaters 157 functions to individually heat detection chambers of a set of detection chambers 213 within a microfluidic cartridge 210. Each detection chamber heater in the set of detection chamber heaters 157 is preferably configured to heat one side of one detection chamber in the set of detection chambers 213, and is preferably located such that the extended configuration 146b of the linear actuator 146 of the cartridge receiving module 140 puts a detection chamber in proximity to a detection chamber heater. As mentioned above, the set of detection chamber heaters 157 is preferably coupled to springs or an elastomeric layer to ensure direct contact between the set of detection chamber heaters and a set of detection chambers, without compressively damaging the set of detection chamber heater 157. Preferably, each detection chamber heater is configured to contact a surface of a detection chamber in the extended configuration 146b of the linear actuator 146; however, each detection chamber heater may be further configured to couple to a detection chamber in the extended configuration 146b of the linear actuator 146. In a first variation, the set of detection chamber heaters 157 comprises silicon chip heaters flip chipped to one surface of a flexible printed circuit board, with a set of springs coupled to an opposite surface of the flexible printed circuit board, such that each spring in the set of springs aligns with a

detection chamber heater. In the first variation, contact between each detection chamber heater and a detection chamber is thus maintained by a biasing force provided by an individual spring through the flexible printed circuit board. In a second variation, the set of detection chamber heaters 157 comprises silicon chip heaters flip chipped to one surface of a rigid printed circuit board, with a set of springs coupled to an opposite surface of the rigid printed circuit board. In the second variation, the set of springs thus function to collectively transfer a force through the rigid printed circuit board to maintain contact between the set of detection chamber heaters and a set of detection chambers. Preferably, each detection chamber heater in the set of detection chamber heaters 157 is configured to contact and heat a bottom surface of a detection chamber (in the orientation shown in FIGURE 7B); however, each detection chamber heater may alternatively be configured to contact and heat both a top and a bottom surface of a detection chamber. Additionally, each detection chamber heater preferably corresponds to a specific detection chamber of the set of detection chambers 213 and functions to individually heat the specific detection chamber; however, alternatively, each detection chamber heater may be configured to heat multiple detection chambers in the set of detection chambers 213. Preferably, all detection chamber heaters in the set of detection chamber heaters 157 are identical; however, the set of detection chamber heaters 157 may alternatively not comprise identical detection chamber heaters.

[0057] In one variation, each detection chamber heater in the set of detection chamber heaters 157 comprises a donut-shaped heater, configured to encircle a surface of a detection chamber. The donut-shaped heater may further include a conducting mesh configured to allow detection through the heater while still allowing efficient heat transfer to the detection chamber. In an alternative variation, each detection chamber heater in the set of detection chamber heaters 157 may include a plate-shaped Peltier heater, similar to Peltier cartridge heater 153 described above. In this alternative variation, each detection chamber heater is thus configured to heat one side of a detection chamber through one face of the detection chamber heater. In one specific example, the molecular diagnostic module 130 comprises 12 diced silicon wafers with conductive channels flip chipped to 12 detection chambers, providing resistive heating to each of the 12 detection chambers. In another specific example, the molecular diagnostic module 130 comprises a 12 Peltier detection

chamber heaters configured to heat 12 detection chambers of a microfluidic cartridge 210 aligned within the molecular diagnostic module 130. In other alternative variations, each detection chamber heater may comprise any appropriate heater configured to individually heat a detection chamber.

[0058] The magnet 160 of the molecular diagnostic module 130 functions to provide a magnetic field for isolation and extraction of nucleic acids bound to magnetic beads within a microfluidic cartridge 210, aligned within the molecular diagnostic module 130. Preferably, the magnet 160 is fixed within the molecular diagnostic module 130, such that the extended configuration 146b of the linear actuator 146 allows the magnet 160 to pass through the magnet receiving slot 144 of the cartridge receiving module 140 and into a magnet housing region 218 of the microfluidic cartridge 210. In an example, as shown in FIGURES 7A-7C, the magnet 160 is a rectangular prism-shaped magnet 160 fixed under the cartridge platform 141, and configured to pass through the cartridge platform 141, into a magnet housing region 218 located under the heating region 224 of the microfluidic cartridge 210. Preferably, the magnet 160 is one of two or three magnets lined up in parallel, such that each of the fluidic pathways of a microfluidic cartridge housing the magnets is exposed to two or three times as much magnetic flux, and two to three times as many opportunities to capture magnetic beads. Alternatively, the magnet 160 is a single magnet configured to expose a set of fluidic pathways to a magnetic field. Preferably, the magnet 160 or group of multiple magnets is coupled to a magnet holder within the molecular diagnostic module 130. Additionally, the magnet holder is preferably composed of an insulating material, such that the magnet holder does not interfere with proper functioning of the cartridge heater 153. Alternatively, the magnet holder may not be composed of an insulating material.

[0059] In one variation, the magnet 160 or group of multiple magnets comprises a permanent magnet, composed of a magnetized material (e.g., a ferromagnet) providing a substantially fixed magnetic field. In an alternative variation, the magnet 160 or group of multiple magnets comprises an electromagnet configured to provide a modifiable magnetic field, such that the intensity of the magnetic field can be adjusted, the polarity of the magnetic field can be reversed, and the magnetic field can be substantially removed upon removal of a current flowing within the electromagnet. Preferably, the magnet 160 or group of magnets is also

fixed relative to the molecular diagnostic module 130; however, the magnet 160 or group of magnets may alternatively be configured to translate vertically (in the orientation shown in FIGURE 7B), such that the magnet 160 or group of magnets can extend into and retract from the magnet receiving slot 144 of the cartridge platform 141 and the magnet housing region 218 of the microfluidic cartridge 210. Additionally, the magnet 160 or group of magnets preferably rides on linear bearings and springs (or an elastomeric material) to ensure proper contact with a microfluidic cartridge in an extended configuration 146b of the linear actuator 146, in a manner that allows most of force from the linear actuator 146 to translate to full occlusion of a subset of the set of occlusion positions (i.e., without leakage).

[0060] Alternative configurations and/or compositions of the magnet 160 may also be appropriate in facilitating isolation and extraction of nucleic acids bound to magnetic beads within the microfluidic cartridge 210.

1.2.3 Molecular Diagnostic Module – Valve Actuation Subsystem

[0061] As shown in FIGURES 10A-11C, the valve actuation subsystem 170 of the molecular diagnostic module 130 comprises a set of pins 172 configured to translate linearly within a pin housing 175, by sliding a cam card 177 laterally over the pins 172. The valve actuation subsystem 170 functions to provide a biasing force to deform an object in contact with the set of pins 172. In a configuration wherein a microfluidic cartridge 210 is aligned within the molecular diagnostic module 130, the valve actuation subsystem 170 thus functions to occlude a fluidic pathway 220 of the microfluidic cartridge 210 at a set of occlusion positions 226, to control flow of a biological sample containing nucleic acids, reagents and/or air through the microfluidic cartridge 210. In an embodiment of the molecular diagnostic module shown in FIGURES 7D-7E, the set of pins 172 and the pin housing are located directly under the microfluidic cartridge 210, such that the set of pins can access the microfluidic cartridge 210 through the valve actuation accommodating slots 145 of the cartridge platform 141. The cam card 177 in the embodiment is positioned under the set of pins and is coupled to a linear cam card actuator 178 configured to laterally displace the cam card 177 to vertically displace pins of the set of pins 172. Preferably, as shown in FIGURE 11A, the cam card 177 rests on a low friction surface configured to facilitate lateral displacement of the cam card 177; however, the cam card 177 may alternatively rest on a bed of ball bearings to facilitate lateral displacement of the

cam card 177, or may rest on any feature that allows the cam card 177 to be laterally displaced by the linear cam card actuator 178.

[0062] The cam card 177, as shown in FIGURES 7D and 11A, includes a set of hills 176 and valleys 179, and functions to transform linear motion in one plane to vertical motion in another plane. In one variation, the cam card 177 is coupled to a linear actuator and contacts the ends of pins in a set of pins 172, such that when a hill 176 of the cam card 177 passes under a pin, the pin is in a raised configuration 177a, and when a valley 179 of the cam card 177 passes under a pin, the pin is in a lowered configuration 177b. The hills 176 and valleys 179 of the cam card 177 are preferably in a set configuration, as shown in FIGURE 11B, such that lateral motion of the cam card 177 to a set position raises a fixed subset of the set of pins 172. In this manner, lateral movement of the cam card 177 to different positions of a set of positions consistently raises different subsets of the set of pins 172 to occlude different portions of a fluidic pathway 220 of a microfluidic cartridge 210 in contact with the set of pins 172. Thus, portions of a fluidic pathway 220 may be selectively occluded and opened to facilitate processing of a biological sample according to any appropriate tissue, cellular, or molecular diagnostic assay protocol. In one variation, the cam card is configured to be laterally displaced in two coordinate directions within a plane (e.g., by x-y linear actuators), and in another variation, the cam card is configured to be laterally displaced in only one coordinate direction within a plane (e.g., by a single linear actuator). In a specific example, the hills 176 of the cam card 177 are raised 1mm above the valleys 179 of the cam card 177, the hills 176 and valleys 179 each have a 2mm wide plateau region, and a hill 176 region slopes down to a valley region 179 at a fixed angle over a 2mm length. In the specific example, the cam card 177 is driven by a Firgelli linear actuator. Alternative variations may include any appropriate configurations and geometries of a cam card with hills 176 and valleys 179, driven by any appropriate actuator.

[0063] In alternative embodiments of the valve actuation subsystem 170, the cam card 177 may be a cam card wheel comprising a set of hills 176 and valleys 179 on a cylindrical surface, and configured to convert rotary motion to linear (i.e., vertical) motion of the set of pins 172. The cam card wheel may be configured to contact ends of pins in the set of pins 172, and may be coupled to a motor shaft and driven by a motor. In other alternative embodiments of the valve actuation

subsystem 170, the cam card 177 may altogether be replaced by a set of cams, each configured to individually rotate about an axis. In these alternative embodiments, rotating subsets of the set of cams raises corresponding subsets of the set of pins, and occludes specific portions of a fluidic pathway 220 of a microfluidic cartridge 210 in contact with the set of pins 172.

[0064] The set of pins 172 functions to selectively occlude portions of a fluidic pathway 220 of a microfluidic cartridge 210 at least at subsets of a set of occlusion positions 226. The pins of the set of pins 172 are preferably cylindrical and, in the orientation shown in FIGURE 11A, configured to slide over a cam card 177 and within a pin housing 175. Each pin in the set of pins 172 preferably also includes a first spring 173 that functions to provide a counteracting force to restore a pin to a lowered configuration 177b; however, each pin in the set of pins 172 may alternatively not include a first spring 173, and rely solely on gravity to return to a lowered configuration 177b. Preferably, as shown in FIGURE 11C, each pin is also composed of two parts separated by a second spring, which functions to allow sufficient force to fully occlude a microfluidic channel but prevents forces from being generated that could damage the pin, microfluidic cartridge and/or cam card. Each pin also preferably comprises a first region 171 configured to slide within the pin housing 175, and a second region 174 configured to exit the pin housing 175. The second region 174 is preferably of a smaller dimension than the first region 171, such that each pin is constrained by the pin housing 175 to be raised by a limited amount. Alternatively, the first region 171 and the second region 174 may have any appropriate configuration to facilitate raising and lowering of a pin by a fixed amount. In a specific example, the valve actuation subsystem 170 comprises 12 sets of pins 172 configured to selectively occlude 12 fluidic pathways 212 of a microfluidic cartridge 210 aligned within the molecular diagnostic module; however, other embodiments may comprise any appropriate number of sets of pins 172.

[0065] In the orientation shown in FIGURE 11A, each pin in the set of pins 172 preferably has a circular cross section and round ends, configured to facilitate sliding within a pin housing 175, sliding over a cam card 177 surface, and occlusion of a fluidic pathway 220. Alternatively, each pin may comprise any appropriate cross-sectional geometry (e.g., rectangular) and/or end shape (e.g., flat or pointed) to facilitate occlusion of a fluidic pathway 220. Preferably, the surface of each pin in the

set of pins 172 is composed of a low-friction material to facilitate sliding motions (i.e., over a cam card 177 or within a pin housing 175); however, each pin may alternatively be coated with a lubricant configured to facilitate sliding motions.

[0066] The pin housing 175 functions to constrain and guide the motion of each pin in the set of pins 172, as the cam card 177 slides under the set of pins 172. Preferably, the pin housing 175 comprises a set of pin housing channels 169 configured to surround at least one pin in the set of pins 172. In one variation, each pin in the set of pins 172 is surrounded by an individual channel of the set of pin housing channels 169; however, in another variation a channel of the set of pin housing channels 169 may be configured to surround multiple pins in the set of pins 172. In an example shown in FIGURES 7D-7E and 11A, the pin housing is located under the cartridge platform 141, such that the set of pin housing channels 169 is aligned with the set of valve actuation accommodating slots 145, to provide access, by the set of pins 172, to a microfluidic cartridge 210 aligned on the cartridge platform 141. In the example, the pin housing 175 thus constrains the set of pins 172, such that each pin can only move linearly in a vertical direction. Each pin housing channel preferably has a constricted region 168 configured to limit the motion of a pin within a pin channel; however, each pin housing channel may alternatively not include a constricted region. Preferably, surfaces of the pin housing 175 contacting the set of pins 172 are composed of a low friction material to facilitate sliding of a pin within a pin housing channel; however, surfaces of the pin housing 175 contacting the set of pins 172 may alternatively be coated with a lubricant configured to facilitate sliding motions. Other variations of the pin housing 175 and the set of pins 172 may include no additional provisions to facilitate sliding of a pin within a pin housing channel.

1.2.4 Molecular diagnostic module – Optical Subsystem

[0067] As shown in FIGURES 12A-12D, the optical subsystem 180 of the molecular diagnostic module 130 comprises a set of light emitting diodes (LEDs) 181, a set of excitation filters 182 configured to transmit light from the set of LEDs 181, a set of dichroic mirrors 183 configured to reflect light from the set of excitation filters 182 toward a set of apertures 185 configured to transmit light toward a set of nucleic acid samples, a set of emission filters 186 configured to receive and transmit light emitted by the set of nucleic acid samples, and a set of photodetectors 187 configured to facilitate analysis of light received through the set of emission filters 186. The

optical subsystem 180 may further comprise a set of lenses 184 configured to focus light onto the set of nucleic acid samples. The optical subsystem 180 thus functions to transmit light at excitation wavelengths toward a set of nucleic acid samples and to receive light at emission wavelengths from a set of nucleic acid samples. Preferably, the optical subsystem 180 is coupled to an optical subsystem actuator 188 configured to laterally displace and align the optical subsystem 180 relative to the set of nucleic acid samples, and is further coupled to a linear actuator 146 of the cartridge receiving module 140 to position the optical subsystem 180 closer to the set of nucleic acid samples. Alternatively, the optical subsystem 180 may not be coupled to a linear actuator 146 of the cartridge receiving module 140, and may only be configured to translate laterally in one direction. In a specific example, the optical subsystem 180 comprises a set of 12 apertures, a set of 12 lenses, a set of 12 dichroic mirrors, a set of 12 excitation filters, a set of 12 LEDs, a set of 12 emission filters, and a set of 12 photodetectors. In the specific example, as shown in FIGURE 7A-7E, the optical subsystem 180 is located within the molecular diagnostic module 130 and coupled to the linear actuator 146 of the cartridge receiving module 140, such that, in the extended configuration 146b of the linear actuator 146, the optical subsystem 180 can be positioned closer to a microfluidic cartridge 210 aligned within the molecular diagnostic module. Conversely in the specific example, the optical subsystem 180 is positioned away from the microfluidic cartridge 210 in the retracted configuration 146a of the linear actuator 146. In the specific example, the optical subsystem 180 is further coupled to an optical subsystem actuator 188 configured to laterally displace the optical subsystem 180 relative to the microfluidic cartridge 210, such that the optical subsystem 180 can be aligned with a set of detection chambers 213 of the microfluidic cartridge 210.

[0068] Preferably, the set of LEDs 181 are not all identical but rather chosen to efficiently produce a certain band of wavelengths of light, such that light from the set of LEDs 181 can be filtered to appropriate narrow wavelengths for analysis of nucleic acid samples. Alternatively, all LEDs in the set of LEDs 181 may be identical, and produce white light comprising all wavelengths of visible light that is filtered to produce the desired wavelength, in which case the LEDs may be stationary. Preferably, the set of LEDs 181 includes phosphor-based LEDs, but the set of LEDs 181 may alternatively include any LEDs configured to provide light of the desired

range of wavelengths. The LEDs of the set of LEDs 181 are preferably configured to emit light of wavelengths corresponding to at least one of the set of excitation filters 182, the set of dichroic mirrors 183, and the set of emission filters 186.

[0069] The set of excitation filters 182 is configured to align with the set of LEDs 181 in the optical subsystem 180, and functions to transmit light at excitation wavelengths toward the set of dichroic mirrors 183 of the optical subsystem 180. Preferably, the set of excitation filters 182 are not identical excitation filters, but rather chosen to transmit the different desired ranges of excitation wavelengths. Alternatively, all excitation filters of the set of excitation filters 182 are identical, and configured to transmit light having a fixed range of excitation wavelengths. In one variation, the set of excitation filters 182 includes band pass filters, configured to transmit light between two bounding wavelengths, in another variation, the set of excitation filters 182 includes short pass filters configured to transmit light below a certain wavelength, and in yet another variation, the set of excitation filters 182 includes long pass filters configured to transmit light above a certain wavelength. Preferably, the set of excitation filters 182 is interchangeable, such that individual excitation filters may be interchanged to provide different excitation wavelengths of light; however, the set of excitation filters 182 may alternatively be fixed, such that the optical subsystem 180 is only configured to transmit a fixed range of excitation wavelengths.

[0070] The set of dichroic mirrors 183 is configured to align with the set of excitation filters 182, and functions to receive and reflect light from the set of excitation filters 182 toward the detection chamber, such that light having a range of excitation wavelengths may be focused, through a set of apertures, onto a set of nucleic acid samples. The set of dichroic mirrors 183 also functions to receive and transmit light from a set of emission filters 186 toward a set of photodetectors 187, which is described in more detail below. All dichroic mirrors in the set of dichroic mirrors 183 are preferably identical in orientation relative to the set of excitation filters 182 and the set of emission filters 186, and configured to reflect and transmit the appropriate wavelengths of light for the given LED. Alternatively, the set of dichroic mirrors 183 may include identical dichroic mirrors, with regard to orientation, light transmission, and light reflection. In a specific example, in the orientation shown in FIGURE 12A, the set of excitation filters 182 is oriented

perpendicular to the set of emission filters 186, with the set of dichroic mirrors 183 bisecting an angle between two planes formed by the faces of the set of excitation filters 182 and the set of emission filters 186. In the specific example, light from the set of excitation filters is thus substantially reflected at a 90° angle toward the set of apertures 185, and light from the set of emission filters 186 passes in a substantially straight direction through the set of dichroic mirrors 183 toward the set of photodetectors 187. Other variations of the set of dichroic mirrors 183 may include any configuration of dichroic mirrors, excitation filters, and/or emission filters that enable transmission of light of excitation wavelengths toward a set of nucleic acid samples, and transmission of light from the set of nucleic acid samples toward a set of photodetectors 187.

[0071] In one embodiment, the optical subsystem may further include a set of lenses 184 configured to align with the set of dichroic mirrors 183, which functions to focus light, from the set of excitation filters 182 and reflected off of the set of dichroic mirrors 183, onto a set of nucleic acid samples configured to emit light in response to the light from the set of excitation filters 182. All lenses in the set of lenses 184 are preferably identical in orientation relative to the set of dichroic mirrors and in dimension; however, the set of lenses 184 may alternatively comprise non-identical lenses, such that light passing through different lenses of the set of lenses 184 is focused differently on different nucleic acid samples. In a specific example, in the orientation shown in FIGURE 12A, the faces of the set of lenses 184 are oriented perpendicular to the faces of the set of excitation filters 182, to account for light reflection by the set of dichroic mirrors 183 at a 90° angle. In the specific example, the set of lenses also includes identical ¼” high numerical aperture lenses. In other variations, the set of lenses 184 may be oriented in any appropriate configuration for focusing light from the set of dichroic mirrors 183 onto a set of nucleic acid samples, and may include lenses of any appropriate specification (i.e., numerical aperture).

[0072] The set of apertures 185 is located on an aperture substrate 189 and configured to align with the set of lenses 184, and functions to allow focused light from the set of lenses 184 to pass through to the set of nucleic acid samples. The aperture substrate 189 is preferably coupled to the linear actuator 146 of the cartridge receiving module 140, which allows the optical subsystem 180 to linearly translate and be positioned near and away from a microfluidic cartridge 210 aligned

within the molecular diagnostic module 130. Alternatively, the aperture substrate 189 may not be coupled to the linear actuator 146 of the cartridge receiving module 140. Preferably, all apertures 185 in the set of apertures 185 are identical, and configured to allow identical light profiles to be focused, through the set of lenses 184, onto a set of nucleic acid samples. Alternatively, the set of apertures 185 may not include identical apertures. In one variation, each aperture in the set of apertures 185 may be individually adjustable, in order to provide individually modifiable aperture dimensions (e.g., width, length, or diameter) to affect light exposure. In an alternative variation, each aperture in the set of apertures 185 is fixed. Other variations may include interchangeable aperture substrates 189, such that features of the set of apertures (e.g., aperture dimensions, number of apertures) may be adjusted by interchanging aperture substrates 189.

[0073] The set of emission filters 186 is configured to align with the set of dichroic mirrors, and functions to transmit emission wavelengths of light from the set of nucleic acid samples, and to filter out excitation wavelengths of light. Preferably, each emission filter of the set of emission filters 186 are configured to transmit light having a fixed range of emission wavelengths, while blocking light of excitation wavelengths. Alternatively, the set of emission filters 186 may comprise identical emission filters, such that individual emission filters of the set of emission filters 186 are configured to transmit the same ranges of emission wavelengths. In one variation, the set of emission filters 186 includes band pass filters, configured to transmit light between two bounding wavelengths, in another variation, the set of emission filters 186 includes short pass filters configured to transmit light below a certain wavelength, and in yet another variation, the set of emission filters 186 includes long pass filters configured to transmit light above a certain wavelength. Preferably, the set of emission filters 186 is interchangeable, such that individual emission filters may be interchanged to transmit and/or block different wavelengths of light; however, the set of emission filters 186 may alternatively be fixed, such that the optical subsystem 180 is only configured to transmit a fixed range of emission wavelengths.

[0074] The set of photodetectors 187 is configured to align with the set of emission filters 186, and functions to receive light from the set emission filters to facilitate analysis of the set of nucleic acid samples. All photodetectors in the set of

photodetectors 187 are preferably identical; however, the set of photodetectors 187 may alternatively include non-identical photodetectors. Preferably, the set of photodetectors 187 includes photodiodes comprising a photoelectric material configured to convert electromagnetic energy into electrical signals; however, the set of photodetectors 187 may alternatively comprise any appropriate photodetectors for facilitating analysis of biological samples, as is known by those skilled in the art.

[0075] The optical subsystem actuator 188 is coupled to the optical subsystem 180, and functions to laterally translate the optical subsystem 180 relative to a set of nucleic acid samples being analyzed. Preferably, the optical subsystem actuator 188 is a linear actuator configured to translate the optical subsystem 180 in one dimension; however, the optical subsystem actuator 188 may alternatively be an actuator configured to translate the optical subsystem 180 in more than one dimension. In a specific example, as shown in FIGURES 7A-7D and 12D, the optical subsystem actuator 188 is configured to translate the optical subsystem 180 laterally in a horizontal plane, to align the optical subsystem 180 with a set of detection chambers 213 of a microfluidic cartridge 210 within the molecular diagnostic module 130. In another example, the optical subsystem may be configured as a disc revolving around an axis with the LEDs and photodetectors stationary and the disc containing the filters. In other variations, the optical subsystem actuator 188 may be configured in any appropriate manner to facilitate alignment of the optical subsystem 180 relative to a set of nucleic acid samples being analyzed.

1.2.5 Molecular Diagnostic Module – Alternative Embodiments and Variations

[0076] As described above, alternative embodiments of the molecular diagnostic module 130 and alternative variations of subsystems and elements of the molecular diagnostic module 130 may be configured to process a biological sample containing nucleic acids, isolate nucleic acids from the biological sample, and detect nucleic acids. An example of an alternative embodiment of a molecular diagnostic module 130, as shown in FIGURE 13, includes a cartridge receiving module 140', a heating and cooling subsystem 150', a magnet 160', a valve actuation subsystem 170', and an optical subsystem 180', and functions to manipulate an alternative microfluidic cartridge 210' for processing of biological samples containing nucleic acids. Other alternative embodiments of the molecular diagnostic module 130" may

be configured to receive alternative microfluidic cartridges 210”, for processing of biological samples containing nucleic acids.

1.3 System – Assay Strip

[0077] As shown in FIGURES 18A and 18B, the assay strip 190 comprises an assay strip substrate 191 comprising a set of wells 192, and typically a puncturable foil seal 195, and functions to facilitate combination of a set of nucleic acid samples with a set of molecular diagnostic reagents for amplification and/or detection of a nucleic acid sequence or sequences. Preferably, the entire assay strip 190 is configured to be a consumable (i.e., disposable), such that the assay strip 190 can be used during multiple runs of the system 100, then the assay strip 190 is disposed of once all of the wells 192, containing unitized reagents for a single test or group of tests, is exhausted. Alternatively, at least a portion of the assay strip 190 is configured to be reusable, such that wells may be reloaded with reagents and reused with the system 100. In one variation of the assay strip 190, the assay strip substrate 191 is reusable, while the puncturable foil seal 195 is disposable and replaced after each run of the system 100. In another variation, the reusable assay strip substrate 191 does not require a puncturable foil seal 195, such that reagents specific to a certain nucleic acid sequences may be deposited into open wells of the assay strip substrate 191 by a user.

[0078] The assay strip substrate 191 is configured such that the assay strip 190 is capable of resting on a flat surface, and functions to define the set of wells 192 and to couple to the puncturable foil seal 195. The assay strip substrate 191 is preferably configured to be received by a corresponding assay strip holder 230 configured to hold multiple assay strips 190, but may alternatively not be configured to couple to an assay strip holder 230. The assay strip substrate 191 is preferably composed of a PCR-compatible polymer, such as polypropylene, that can be heat processed to couple to the puncturable foil seal 115, but can alternatively be composed of any appropriate material that can contain a fluid and be bonded to the puncturable foil seal 115.

[0079] The set of wells 192 of the assay strip substrate 191 function to receive at least one nucleic acid sample, and to facilitate combination of the nucleic acid sample with at least one of a set of molecular diagnostic reagents. The molecular diagnostic reagents of the set of molecular diagnostic reagents preferably comprise

reagents configured to analyze the set of nucleic acid volumes for markers of at least one of gonorrhea (GC), Chlamydia (CT), herpes simplex virus (HSV), human immunodeficiency virus (HIV), human respiratory diseases, vaginal diseases, hepatitis C virus (HCV), hepatitis B virus (HBV), trichomonas, group B streptococcus (GBS), factor 2 (FII) gene, and factor five (FV) gene, but may alternatively comprise reagents used to perform alternative molecular diagnostic protocols. Preferably, the wells 193 of the assay strip substrate 191 are each configured to accommodate not only a nucleic acid sample, but also to facilitate mixing of the nucleic acid sample with at least one of a set of molecular diagnostic reagents (e.g., using a pipettor or other apparatus). Additionally, the molecular diagnostic reagents of the set of molecular diagnostic reagents preferably comprises probes and primers to detect the sample process controls provided by the capture plate, in order to verify process fidelity and assay accuracy. Preferably, the wells 193 are deep enough to facilitate mixing without splashing, and evenly spaced to facilitate aspiration, delivery, and/or mixing of multiple biological samples (e.g., with a multi-tip pipettor). Alternatively, the wells are wide and shallow to facilitate drying of reagents in the wells to increase shelf life and larger devices for mixing the nucleic acids with molecular diagnostic reagents. Each well 193 of the set of wells 192 also preferably has a rounded bottom region, as shown in FIGURE 18A, to facilitate complete aspiration of a fluid from a well 193; however, each well 193 may alternatively not have a rounded bottom region. Additionally, the set of wells 192 is preferably arranged in staggered rows, which functions to facilitate access to individual wells 193 of the set of wells, to reduce one dimension of the assay strip 190, and also to prevent cross-contamination of fluids within the wells due to dripping. Alternatively, the set of wells 192 may not be arranged in staggered rows.

[0080] The puncturable foil seal 195 functions to protect the molecular diagnostic reagents stored in wells 112 from degradation, isolate each well 193 of the set of wells 192, prevent contamination of the contents of each of the set of wells 192, and provide information identifying the assay strip 190. The puncturable foil seal 195 preferably seals each well 193 of the assay strip 190, and is configured to be punctured by an external element (e.g., by a pipette tip), such that each well is sealed prior to being punctured. In one variation, the puncturable foil seal 195 also forms a seal around an element that punctures it, and in another variation, the puncturable

foil seal 195 does not form a seal around an element that punctures it, in order to prevent airlock. The puncturable foil seal 195 is also preferably labeled with identifying information including at least one of manufacturer information, assay strip contents, the lot of the contents, an expiry date, and a unique electronic tag (e.g., barcode or QR code) providing more information. Preferably, the puncturable foil seal 195 does not extend beyond the footprint of the assay strip 190, but alternatively, the puncturable foil seal 195 may be any appropriate size and/or include protruding features (e.g., tabs) that facilitate handling of the assay strip.

[0081] In one variation, the assay strip 190 may be prepackaged with a set of molecular diagnostic reagents, such that each well 193 in the set of wells 192 is prepackaged with a quantity of molecular diagnostic reagents. The set of wells 192 may then be sealed by the puncturable foil seal 195, which is configured to be punctured by an external element that delivers volumes of nucleic acid samples to be combined with the set of molecular diagnostic reagents. In another variation, the assay strip 190 may not be prepackaged with a set of molecular diagnostic reagents, and the wells 193 of the assay strip 190 may not be sealed with a puncturable foil seal 195. In yet another variation, the system may comprise an empty assay strip 190 without a puncturable foil seal 195, and an assay strip 190 comprising reagents and a puncturable foil seal 195, such that a user may add specific reagents to the empty assay strip to be used in conjunction with the assay strip comprising reagents. In variations comprising a puncturable foil seal 195, the puncturable foil seal 115 is configured to be punctured by at least one external element, for co-delivery of nucleic acid samples and molecular diagnostic reagents intended to be combined.

[0082] In a specific example, the assay strip 190 has an 87mm x 16mm footprint and comprises 24 wells 113 arranged in two staggered rows, with a 9mm center-to-center pitch between adjacent wells 193 within each row. Each well 193 of the set of wells has a capacity of 60 μ L to accommodate a volume of a molecular diagnostic reagent, 20 μ L of a sample fluid, and any displacement caused by a pipette tip (e.g., 100 or 300 μ L pipette tip). Each well 113 of the assay strip 190 in the specific example is also prepackaged with a quantity of molecular diagnostic reagents, and comprises a protruding top edge (75 microns high) that is heat sealed to a puncturable foil seal. The capture plate 110 in the specific example is produced by injection molding, has a footprint of 127.75mm x 85.5mm, and is composed of a

PCR-compatible polypropylene based polymer with a high vapor barrier. In the specific embodiment, the vapor barrier is further increased by depositing a thin metallic layer to the outside of the assay strip 190.

[0083] As described earlier, the assay strip 190 may be configured to be received by an assay strip holder 230. The assay strip holder 230 functions to receive and align multiple assay strips 190, such that a multichannel pipettor or other fluid delivery system may combine multiple nucleic acid samples with molecular diagnostic reagents using wells 193 of multiple assay strips 190. In one variation, the assay strip holder 230 may be configured to contain Assay strips 190 including reagents for substantially different molecular diagnostic assays, as shown in FIGURE 17B, such that a single run of the system 100 involves analyzing a set of nucleic acid samples under different molecular diagnostic assays. In another variation, the assay strip holder 230 may be configured to contain assay strips 190 including reagents for identical molecular diagnostic assays, such that a single run of the system 100 involves analyzing a set of nucleic acid samples under the same molecular diagnostic assay. Preferably, the assay strip holder 230 is composed of a material that is dishwasher safe and autoclavable, configured to hold the assay strips 190 in place during handling by a fluid delivery system (e.g., pipettor), and configured such that the assay strips 190 avoid protruding over an edge of the assay strip holder 230, but the assay strip holder 230 is constructed to facilitate insertion and removal of the assay strips 190 from the assay strip holder 230.

[0084] In one variation, the assay strip holder 230 is not configured to facilitate cooling of molecular diagnostic reagents within the assay strips 190; however, in another variation as shown in FIGURE 21A, the assay strip holder 230 may be further configured to couple to an aluminum block 235 coupled to a set of Peltier units 236 configured to facilitate cooling of molecular diagnostic reagents within the assay strips 190. Additionally, the assay strip holder 230 may be configured to be received and carried by an assay strip carrier 240, which, as shown in FIGURE 20, functions to facilitate handling and alignment of multiple assay strip holders 230. In a specific example, as shown in FIGURE 19, the assay strip holder 230 has dimensions of 127.76mm x 85.48mm x 14.35mm, complies with American National Standards Institute (ANSI) and Society for Laboratory Automation and Screening (SLAS) standards, and is configured to hold six 16-well assay strips for a

total of 96 wells 193. In another specific example, as shown in FIGURE 21B, the assay strip holder 230' is configured to hold four assay strips 190', each comprising 24 wells 193' for a total of 96 wells per assay strip holder 230'. Other combinations of the described embodiments, variations, and examples of the assay strip 190, assay strip holder 230, and assay strip carrier 240 may be incorporated into embodiments of the system 100 for processing and detecting nucleic acids.

1.4 System – Microfluidic Cartridge

[0085] The microfluidic cartridge 210 functions to receive a set of magnetic bead-samples, facilitate separation of nucleic acids from the set of magnetic bead-samples, receive a set of nucleic acid-reagent samples, and facilitate analysis of nucleic acids from the set of nucleic acid-reagent samples. In one embodiment, the microfluidic cartridge 210 comprises a top layer 211 including a set of sample port-reagent port pairs 212 and a set of detection chambers 213; an intermediate substrate 214, coupled to the top layer 211 and partially separated from the top layer 211 by a film layer 215, configured to form a waste chamber 216; an elastomeric layer 217 partially situated on the intermediate substrate 214; a magnet housing region 218 accessible by a magnet 160 providing a magnetic field; and a set of fluidic pathways 219, each formed by at least a portion of the top layer 211, a portion of the film layer 215, and a portion of the elastomeric layer 217. In the embodiment, the microfluidic cartridge 10 further comprises a bottom layer 221 coupled to the intermediate substrate 214 and configured to seal the waste chamber 216. Furthermore, in the embodiment, the top layer 211 of the microfluidic cartridge 210 further comprises a shared fluid port 222, a vent region 223, and a heating region 224, such that each fluidic pathway 220 in the set of fluidic pathways 219 is fluidically coupled to a sample port-reagent port pair 224, the shared fluid port 222, the waste chamber 216, and a detection chamber 225, comprises a turnabout portion 226 configured to pass through the heating region 224 and the magnetic field, and is configured to pass through the vent region 223 upstream of the detection chamber 225. Each fluidic pathway 220 thus functions to receive and facilitate processing of a sample fluid containing nucleic acids as it passes through different portions of the fluidic pathway 220.

[0086] The microfluidic cartridge 210 is preferably configured to be received and manipulated by the molecular diagnostic module 130, such that the cartridge

receiving module 140 of the molecular diagnostic module 130 receives and aligns the microfluidic cartridge 210 within the molecular diagnostic module 130, the heating and cooling subsystem 150 of the molecular diagnostic module 130 is configured to transfer heat to the heating region 224 of the microfluidic cartridge 210, and the magnet 160 of the molecular diagnostic module 130 is configured to be received by the magnet housing region 218 of the microfluidic cartridge 210 to provide a magnetic field for separation of nucleic acids. Additionally, the shared fluid port 222 of the microfluidic cartridge 210 is configured to couple to a nozzle 149 coupled to the linear actuator 146 of the cartridge receiving module 140, such that the liquid handling system 250 can deliver fluids and gases through the shared fluid port 222. The elastomeric layer 217 of the microfluidic cartridge 210 is also preferably configured to be occluded at a set of occlusion positions 226 by the valve actuation subsystem 170 of the molecular diagnostic module, in order to occlude portions of a fluidic pathway 220 of the microfluidic cartridge 210 for processing of a set of biological samples. The optical subsystem 180 of the molecular diagnostic module 130 is further configured to align with the set of detection chambers 213 of the microfluidic cartridge 210, to facilitate analysis of a set of nucleic acid samples. The microfluidic cartridge 210 is preferably the microfluidic cartridge 210 described in U.S. Application number 13/765,996, which is incorporated in its entirety by this reference, but may alternatively be any appropriate cartridge or substrate configured to receive and process a set of samples containing nucleic acids.

1.5 System – Fluid Handling System and Filter

[0087] The liquid handling system 250 of the system 100 includes a liquid handling arm 255 and a syringe pump 265, as shown in FIGURES 14A-14C and functions to deliver biological samples, reagents, and gases to elements of the system 100. As described in Section 1, an embodiment of the liquid handling system 250 is configured to aspirate a set of biological samples containing nucleic acids (i.e., impure nucleic acid samples), dispense the set of biological samples into a capture plate 110 to be lysed and combined with magnetic beads by a capture plate module 120, aspirate the set of biological samples combined with magnetic beads (i.e., set of magnetic bead-samples) from the capture plate 110, and dispense the set of magnetic bead-samples into microfluidic cartridge 210 located in a molecular diagnostic module 130. The embodiment of the liquid handling system 100 is further configured

to facilitate separation of a set of nucleic acids from the magnetic bead-samples, by dispensing a wash solution, a release solution, and/or air into the molecular diagnostic module 130, by the nozzle 149 coupled to the linear actuator 146, at appropriate stages, aspirate the set of nucleic acids from the molecular diagnostic module 130, combine the set of nucleic acids with a set of molecular diagnostic reagents using an assay strip 190, and dispense the set of nucleic acids combined with the set of molecular diagnostic reagents (i.e., set of nucleic acid-reagent mixtures) into the molecular diagnostic module 130 for further processing and analysis. [Other embodiments of the liquid handling system 250 may be configured to perform alternative molecular diagnostic assay protocols and/or dispense and aspirate alternative fluids into and from other elements supporting a molecular diagnostic protocol.

[0088] The liquid handling arm 255 comprises a gantry 256 and a multichannel liquid handling head 257, and functions to travel to different elements of the system 100 for fluid delivery and aspiration. The liquid handling arm 255 is preferably automated and configured to move, aspirate, and deliver fluids automatically, but may alternatively be a semi-automated liquid handling arm 255 configured to perform at least one of moving, aspirating, and delivering automatically, while another entity, such as a user, performs the other functions.

[0089] The gantry 256 is coupled to the multichannel liquid handling head 257, and functions to transport the multichannel liquid handling head 257 to different elements of the system 100 for fluid delivery and aspiration. Preferably, the gantry 256 is automated and configured to translate the multichannel liquid handling head 257 within at least two dimensions, and provides X-Y positional accuracy of at least 0.5mm. Additionally, in the orientation shown in FIGURE 14B, the gantry is preferably situated above the molecular diagnostic module 130, such that the gantry 256 can translate within at least two dimensions without interfering with other elements of the system 100. Alternatively, the gantry 256 may be any appropriate gantry 256 to facilitate movement of an end effector within at least two dimensions, as is readily known by those skilled in the art.

[0090] The multichannel liquid handling head 257 functions to aspirate fluids from and deliver fluids to different elements of the system 100. Preferably, the multichannel liquid handling head 257 is a multichannel pipette head; however, the

multichannel liquid handling head 257 may alternatively be any appropriate multichannel liquid handling head configured to deliver fluids and/or gases. Preferably, the multichannel liquid handling head 257 comprises at least eight independent channels 258, but may alternatively comprise any number of channels 258 configured to aspirate and deliver fluids. The channel-to-channel pitch is preferably variable, and in a specific example ranges between 9mm and 36mm; however, the channel-to-channel pitch may alternatively be fixed, as shown in FIGURE 15. The multichannel liquid handling head 257 also preferably provides independent z-axis control (in the orientation shown in FIGURE 14B), such that, in combination with the gantry 256. The multichannel liquid handling head 257 is preferably configured to couple to both large (e.g., 1mL) and small (e.g., between 100 and 300 μ L) pipette tips, and in a specific example, has a precision of at least 6% using small disposable pipette tips and a precision of at least 2% using large disposable pipette tips when dispensing essentially the entire tip volume. Alternatively, the multichannel liquid handling head 257 may be configured to couple to any object configured to facilitate aspiration and delivery of fluids. Preferably, the multichannel liquid handling head 257 provides independent control of the channels 258, with regard to volumes of fluid aspirated or delivered, fluid dispensing rates, and/or engaging and disengaging pipette tips. Alternatively, the multichannel liquid handling head 257 may not provide independent control of the channels 258, such that all channels 258 of the multichannel liquid handling head 257 are configured to perform identical functions simultaneously. Preferably, the multichannel liquid handling head 257 is configured to aspirate and deliver both liquids and gases, but alternatively, the multichannel liquid handling head 257 may be configured to only aspirate and deliver liquids. Preferably, the multichannel liquid handling head 257 provides at least one of liquid level detection, clot detection, and pipette tip engaging/disengaging detection for each of the channels 258; however, the multichannel liquid handling head 257 may alternatively not provide liquid level detection, clot detection, and pipette tip engaging/disengaging detection for each of the channels 258.

[0091] In one embodiment, the multichannel liquid handling head 257 is configured to couple to at least one filter 260, which functions to pre-filter liquids being aspirated and/or dispensed by the liquid handling arm 255, and is preferably a

custom filter 260 configured to couple to a pipette tip, but may alternatively be any appropriate filter configured to couple to the liquid handling arm 255 and filter liquids being aspirated and/or dispensed by the liquid handling arm 255.

[0092] An embodiment of a custom filter 260, as shown in FIGURE 22, comprises a first end 261 configured to couple to a pipette tip, a pointed second end 262, a void 263 coupled to the first end 261 and the pointed second end 262, and a filter membrane 264 subdividing the void 263. The first end 261, as shown in FIGURE 22, preferably comprises a tapered channel configured to provide a friction fit with a pipette tip; however, the first end may alternatively not comprise a tapered channel and may be configured to couple to a pipette tip using any appropriate means. The pointed second end 262 is preferably sharp and configured to pierce an object, such as a foil seal; additionally, the pointed second end 262 is preferably at least as long as required to dispense into a well 113 of the capture plate 110. The void 263 preferably defines a conical region defined by the filter membrane 264, wherein the conical region is configured to divert a fluid within the filter 260 toward the pointed second end 262; however, the void 263 may not include a conical region. The filter membrane 264 functions to filter a fluid aspirated by the multichannel liquid handling head 257, and is configured to subdivide the void 263 to define a conical region; however, the filter membrane 264 may alternatively not define a conical region of the void 263. In one embodiment, in the orientation shown in FIGURE 22, the region of the void 263 below the filter membrane 264 may have a volumetric capacity of between 200ul and 1mL; however, the region of the void 263 below the filter membrane may alternatively have any appropriate volumetric capacity.

[0093] A set of filters 260 may further be configured to be received and delivered by a filter holder 269, as, shown in FIGURE 23. A specific embodiment of a filter holder 269 comprises a set of 24 tapered holes with an 18mm center-to-center pitch, arranged in six rows of four holes. The specific embodiment of the filter holder 269 is also compliant with ANSI and SLAS standards, has dimensions of 127.75 x 85.5 x 14.35mm, and is stackable with other specific embodiments of the custom filter holder 269. Alternatively, the filter holder 269 may be any appropriate filter holder 269 configured to receive and deliver a set of filters 260, as is readily known by those skilled in the art.

1.5.1 Fluid Handling System – Syringe Pump

[0094] The syringe pump 265 of the liquid handling system 250 is coupled to a wash solution source 266, a release solution source 267, a source of air 268, and flexible tubing 291, and functions to deliver a wash solution, a release solution, and air through a valve to the molecular diagnostic module 130 to facilitate isolation and purification of nucleic acids from a set of magnetic bead-samples. The flexible tubing 291 is preferably coupled at a first end to the syringe pump, and at a second end to a nozzle 149 coupled to the linear actuator 146 of the molecular diagnostic module 130, as shown in FIGURE 14C. As stated earlier, an extended configuration 146b of the linear actuator 146 is configured to couple the nozzle 149 to a fluid port 222 of a microfluidic cartridge 210 within the molecular diagnostic module 130, such that the wash solution, release solution, and air can be delivered to the microfluidic cartridge 210 at appropriate stages. A specific embodiment of the syringe pump 265 comprises a 4-way valve, is able to pump 20-5000 μ L of fluids or air through the 4-way valve at flow rates from 50-500 μ L/min, can couple to syringes with between 1mL and 10mL capacities, and has a precision of at least 5% with regard to fluid or air delivery. Alternatively, the syringe pump 265 may be any appropriate syringe pump 265 or fluid delivery apparatus configured to deliver a wash solution, a release solution, and air to the molecular diagnostic module 130, as is readily known by those skilled in the art.

1.6 System – Additional Elements

[0095] The system 100 may further comprise a tag reader 271, which functions to read barcodes, QR codes and/or any other identifying tags of the system 100. Preferably, the tag reader 271 is coupled to the liquid handling system 250, such that the tag reader 271 is configured to read tags on puncturable foil seals 115, 195 or tags located on any element of the system 100 accessible by the liquid handling system 250; however, the tag reader 271 may alternatively not be coupled to the liquid handling system 250. In one alternative embodiment of the system 100, the tag reader 271 may be a standalone unit that is configured to be manipulated by a user to scan tags or labels located on elements of the system 100.

[0096] The system 100 may also further comprise a controller 272 coupled to at least one of the capture plate module 120, the molecular diagnostic module 130, the liquid handling system 250, and the tag reader 271, and functions to facilitate

automation of the system 100. In a variation wherein the controller 272 is coupled to the capture plate module 120, the controller 272 preferably functions to automate heating of a capture plate 110, which facilitates lysing of biological samples within the capture plate 110 and binding of nucleic acids within the capture plate 110 to magnetic beads 119 of the capture plate 110. In a variation wherein the controller 272 is coupled to the molecular diagnostic module 130, the controller 272 preferably functions to automate reception of a microfluidic cartridge, heating of biological samples within the molecular diagnostic module 130 and the detection chambers 213, occlusion of fluidic pathways 220 by the valve actuation subsystem 170, and analysis of a set of nucleic acid-reagent mixtures by the optical subsystem 180. In a variation wherein the controller 272 is coupled to the liquid handling system 250, the controller 272 preferably functions to automate aspiration, transfer, and delivery of fluids and/or gases to different elements of the system 100. In a variation wherein the controller 272 is coupled to the tag reader 271, the controller preferably functions to automate reading of tags by the tag reader 271, and may further function to facilitate transfer of information from the tags to a processor 273. Other variations of a controller may function automate handling, transfer, and/or storage of other elements of the system 100, such as capture plates 110, assay strips 190, assay strip holders 230, assay strip carriers 240, filters 200, filter holders 205, and/or microfluidic cartridges 210, using a robotic arm or gantry similar to that used in the liquid handling system 250. Alternative combinations of the above variations may involve a single controller 272, or multiple controllers configured to perform all or a subset of the functions described above.

[0097] The system 100 may also further comprise a processor 273, which functions to receive and process information from a tag reader 271, and also to receive and process data received from the optical subsystem 180 of the molecular diagnostic module 130. Preferably, the processor 273 is coupled to a user interface 274, which functions to display processed and/or unprocessed data produced by the system 100, settings of the system 100, information obtained from a tag reader 271, or any other appropriate information. Alternatively, the processor 273 is not coupled to a user interface 274, but comprises a connection 275 configured to facilitate transfer of processed and/or unprocessed data produced by the system 100, settings

of the system 100, information obtained from a tag reader 271, or any other appropriate information to a device external to the system 100.

[0098] As a person skilled in the art will recognize from the previous detailed description and from the figures and claims, modifications and changes can be made the described embodiments of the system 100 without departing from the scope of the system 100.

2. Method for Processing and Detecting Nucleic Acids

[0099] An embodiment of a method 400 for processing and detecting nucleic acids from a set of biological samples comprises: combining each biological sample of the set of biological samples with a quantity of magnetic beads to produce a set of magnetic bead-sample mixtures S410; heating the set of magnetic bead-sample mixtures to produce a set of nucleic acid-magnetic bead samples S420; transferring each nucleic acid-magnetic bead sample of the set of nucleic acid-magnetic bead samples to a corresponding fluidic pathway of a set of fluidic pathways S430; producing a set of nucleic acid volumes from the set of nucleic acid-magnetic bead samples S440; combining each nucleic acid volume of the set of nucleic acid volumes with a molecular diagnostic reagent of a set of molecular diagnostic reagents to produce a set of nucleic acid-reagent mixtures S450; transferring each of the set of nucleic acid-reagent mixtures, through the corresponding fluidic pathway of the set of fluidic pathways, to a detection chamber of a set of detection chambers S460; and receiving light from the set of nucleic acid-reagent mixtures S470. The method 400 may further comprise generating a set of data based on light received from the set of nucleic acid-reagent mixtures S480. The method 400 functions to isolate and extract a set of nucleic acid volumes from a biological sample, and to facilitate analysis of the nucleic acid volumes according to at least one molecular diagnostic protocol.

[00100] Step S410 recites combining each biological sample of the set of biological samples with a quantity of magnetic beads to produce a set of magnetic bead-sample mixtures, and functions to prepare a set of biological samples to be lysed and combined with magnetic beads. For each biological sample, Step S410 preferably comprises aspirating a portion of the volume of the biological sample from a sample container (possibly containing an aqueous solution prior to addition of biological sample), and transferring the portion of the biological sample to a well containing a set of magnetic beads. Alternatively, for each biological sample, Step

S410 may comprise aspirating the entire volume of the biological sample from a sample container, and transferring the volume of the biological sample to be combined with a set of magnetic beads. Preferably, all biological samples in the set of biological samples are aspirated and combined with the magnetic beads in the wells simultaneously using a multichannel fluid delivery system; however, all biological samples in the set of biological samples may alternatively be aspirated and combined with a set of magnetic beads non-simultaneously. The magnetic beads are preferably polymer beads, precoupled with a ligand for binding to a nucleic acid, and comprising a superparamagnetic component. Additionally, the magnetic beads may be treated to be positively charged. However, the magnetic beads may alternatively be any appropriate magnetic beads configured to facilitate biomagnetic separation.

[00101] In addition to combination with magnetic beads, Step 410 may further include combining each biological sample of the set of biological samples with a lysing enzyme (e.g. proteinase K), and a sample process control comprising two or more nucleic acid sequences (i.e., one for DNA and one for RNA) to be included with each sample. This allows biological samples to effectively lysed, which releases waste components into a wash solution, and allows nucleic acids to bind to magnetic beads. This additionally allows the sample process control to be later detected, as a check to verify the accuracy of a molecular diagnostic assay being performed.

[00102] In a first variation of Step S410 for one biological sample, as shown in FIGURE 16A, a volume of the biological sample is aspirated and combined with a set of magnetic beads. In the first variation of Step S410, a set of different biological samples may thus be aspirated simultaneously, and each biological sample may be transferred to an individual well to be combined with a set of magnetic beads to produce a set of magnetic bead-sample mixtures. In the first variation of Step S410, all magnetic bead-sample mixtures in the set of magnetic bead-sample mixtures are substantially non-identical in composition. In a second variation of Step S410, as shown in FIGURE 16B, a volume of a stock biological sample is aspirated, and portions of the volume of the stock biological sample are transferred to multiple wells to be combined with multiple sets of magnetic beads to produce a set of magnetic bead-sample mixtures. In the second variation of Step S410, all magnetic bead-sample mixtures in the set of magnetic bead-sample mixtures are substantially identical in composition. Other variations of Step S410 may comprise filtering at

least one biological sample of the set of biological samples S415 prior to combining each biological sample of the set of biological samples with a quantity of magnetic beads.

[00103] In a specific example of Step S410, a multichannel liquid handling system aspirates approximately 1mL of each of a set of biological samples in aqueous buffer using a set of 1mL pipette tips, couples each of the pipette tips to a custom 13mm diameter filter, punctures a foil seal 115 of a capture plate at a set of wells, wherein each well of the set of wells contains a set of magnetic beads, and dispenses each aspirated volume of a biological sample into a well of the capture plate containing a set of magnetic beads, and disposes of the tip/filter combination. In the specific example of Step S410, the multichannel liquid handling system then picks up new disposable tips and aspirates and dispenses the contents of each well at least three times to mix the contents, and then disposes of the set of pipette tips and filters.

[00104] Step S420 recites heating the set of magnetic bead-sample mixtures to produce a set of nucleic acid-magnetic bead samples, and functions to incubate the set of magnetic bead-sample mixtures in order to lyse biological matter, and release nucleic acids to be bound to magnetic beads. Preferably, Step S420 comprises heating a capture plate containing the set of magnetic bead-sample mixtures for a specified amount of time at a specified temperature, and may additionally include cooling the set of magnetic bead-sample mixtures. In a specific example, Step S420 comprises heating a capture plate containing the set of magnetic bead-sample mixtures using a capture plate module, wherein the capture plate module is configured to cradle and controllably heat wells containing the set of magnetic bead-sample mixtures. Step S420 may alternatively comprise incubating the set of magnetic bead-sample mixtures using any appropriate method and/or system as is known by those skilled in the art. Finally, Step S420 may be omitted in embodiments of the method 400 involving samples that do not require heating.

[00105] Step S430 recites transferring each nucleic acid-magnetic bead sample of the set of nucleic acid-magnetic bead samples to a corresponding fluidic pathway of a set of fluidic pathways, and functions to isolate each of the set of nucleic acid-magnetic bead samples within separate pathways for further processing. Preferably, all nucleic acid-magnetic bead samples in the set of nucleic acid-magnetic bead

samples are transferred simultaneously to the set of fluidic pathways, but alternatively, each nucleic acid-magnetic bead sample in the set of magnetic bead-samples may be transferred to a corresponding fluidic pathway independently of the other nucleic acid-magnetic bead samples. In addition, preferably the entire volume, or substantially all of the volume, of the nucleic acid-magnetic bead sample is transferred to the set of fluidic pathways, without magnetically isolating magnetic beads and removing supernatant fluids prior to transferring each nucleic acid-magnetic bead sample of the set of nucleic acid—magnetic bead samples to a corresponding fluidic pathway of a set of fluidic pathways.

[00106] Step S430 may further comprise occluding at least one fluidic pathway of the set of fluidic pathways at a subset of a set of occlusion positions S432, which functions to define at least one truncated fluidic pathway. Preferably, Step S432 comprises defining at least one truncated fluidic pathway passing through at least one of a heating region and a magnetic field; however, Step S432 may alternatively not comprise defining a truncated fluidic pathway passing through at least one of a heating region and a magnetic field.

[00107] In a specific example of Step S430, the multichannel liquid handling subsystem of Step S410 transfers a set of nucleic acid-magnetic bead samples to a set of fluidic pathways of a microfluidic cartridge aligned within a molecular diagnostic module, wherein the microfluidic cartridge comprises an elastomeric layer in contact with the set of fluidic pathways. Manipulation of the elastomeric layer at a subset of a set of occlusion positions by a valve actuation subsystem of the molecular diagnostic module defines a set of truncated fluidic pathways crossing a heating region and a magnetic field, such that each nucleic acid-magnetic bead sample in the set of nucleic acid-magnetic bead samples is isolated within a truncated fluidic pathway of the set of truncated fluidic pathways.

[00108] Step S440 recites producing a set of nucleic acid volumes from the set of nucleic acid-magnetic bead samples, and functions to separate nucleic acid volumes from the set of nucleic acid-magnetic bead samples. Step S440 preferably reduces a concentration of unwanted matter from the set of biological samples being processed, to an acceptable level; however, Step S440 may alternatively entirely remove substantially all unwanted substances from the set of biological samples being processed. Step S440 preferably includes providing a magnetic field S441, such

that each fluidic pathway in the set of fluidic pathways is configured to cross the magnetic field. Preferably, the set of nucleic acid-magnetic bead samples is captured and isolated within portions of the set of fluidic pathways crossing the magnetic field. Step S440 may further comprise providing a heater configured to span a heating region of the set of fluidic pathways S442, but may alternatively comprise providing multiple heaters or altogether omit providing a heater. In embodiments wherein multiple heaters are provided, each heater is preferably independent to allow independent control of heating time and temperature for each sample. Step S442 functions to provide a heater, which, in combination with a release solution that provides a pH shift, facilitate a rapid and efficient unbinding of the nucleic acids from magnetic beads.

[00109] Step S440 may further comprise occluding at least one fluidic pathway of the set of fluidic pathways at a subset of a set of occlusion positions S443 (and opening a previously occluded channel), which functions to define at least one truncated fluidic pathway containing a nucleic acid-magnetic bead sample and coupled to a source for delivery of a wash solution and a release solution. Preferably, Step S443 comprises defining at least one truncated fluidic pathway coupled to a waste chamber and to a fluid port, which functions to facilitate washing of at least one nucleic acid-magnetic bead sample in the set of nucleic acid-magnetic bead samples, and releasing of at least one nucleic acid volume from the set of nucleic acid-magnetic bead samples. Step S440 may additionally comprise delivering a wash solution through a portion of at least one fluidic pathway S444, such as the truncated fluidic pathway defined in Step S443, and delivering a release solution through a portion of at least one fluidic pathway S445, such as the truncated fluidic pathway defined in Step S443. Step S444 functions to wash at least one nucleic acid-magnetic bead sample in the set of nucleic acid-magnetic bead samples, and Step S445 functions to release at least one nucleic acid volume from the set of nucleic acid-magnetic bead samples. The heater provided in Step S442 may be activated after Step S445 to induce a pH shift.

[00110] In a specific example of Step S440, the set of fluidic pathways containing a set of nucleic acid-magnetic bead samples, from the specific example of Step S430, is occluded at a subset of the set of occlusion positions by a valve actuation subsystem of the molecular diagnostic module, to define a set of truncated

fluidic pathways coupled to a waste chamber and to a shared fluid port of the microfluidic cartridge for delivery of a wash solution and a release solution. The liquid handling system delivers a wash fluid through the shared fluid port to wash the set of nucleic acid-magnetic bead samples, captured within the magnetic field, and then delivers a release fluid through the shared fluid port to release a set of nucleic acid volumes from the set of nucleic acid-magnetic bead samples. In the specific example, each fluidic pathway is washed sequentially, and the release solution is delivered to each fluidic pathway sequentially to ensure that each lane is provided with substantially equal amounts of wash and release solutions. All waste fluid produced in the specific example of Step S440 pass into the waste chamber coupled to the set of truncated fluidic pathways.

[00111] Step S450 recites combining each nucleic acid volume of the set of nucleic acid volumes with a molecular diagnostic reagent of a set of molecular diagnostic reagents to produce a set of nucleic acid-reagent mixtures, which functions to prepare the set of nucleic acid volumes to be detected. For each nucleic acid volume in the set of nucleic acid volumes, Step S450 preferably comprises aspirating an entire volume of the nucleic acid volume from its corresponding fluidic pathway, and transferring the nucleic acid volume to a well containing a molecular diagnostic reagent. Preferably, all nucleic acid volumes in the set of nucleic acid volumes are aspirated and combined with molecular diagnostic reagents simultaneously using a multichannel fluid delivery system; however, each nucleic acid volume in the set of nucleic acid volumes may alternatively be aspirated and combined with molecular diagnostic reagents independently of the other nucleic acid volumes. The molecular diagnostic reagents preferably comprise reagents configured to analyze the set of nucleic acid volumes for markers of at least one of gonorrhea (GC), Chlamydia (CT), herpes simplex virus (HSV), human immunodeficiency virus (HIV), human respiratory diseases, vaginal diseases, hepatitis C virus (HCV), hepatitis B virus (HBV), trichomonas, group B streptococcus (GBS), factor 2 (FII) gene, and factor five (FV) gene, but may alternatively comprise reagents used to detect any specific nucleic acid sequence.

[00112] In a first variation of Step S450 as shown in FIGURE 16A, a nucleic acid volume is aspirated and combined with a molecular diagnostic reagent for a single assay. In the first variation of Step S450, a set of nucleic acid volumes may

thus be aspirated simultaneously, and each nucleic acid volume may be transferred to an individual well to be combined with a molecular diagnostic reagent of a set of molecular diagnostic reagents to produce a set of nucleic acid-reagent mixtures. In the first variation of Step S450, all nucleic acid-reagent mixtures in the set of nucleic acid-reagent mixtures may or may not be substantially identical in composition, depending on the homogeneity of the biological samples used in Step S410; however, the first variation of S450 preferably comprises using identical molecular diagnostic reagents, such that identical molecular diagnostic protocols analyzing identical markers may be performed. Thus, the first variation of Step S450 encompasses running multiple identical tests from a stock biological sample (e.g., a multiplex assay), and running identical tests using a set of substantially different biological samples (e.g., from different sources).

[00113] In a second variation of Step S450, as shown in FIGURE 16B, the set of nucleic acid volumes is aspirated, and each nucleic acid volume in the set of nucleic acid volumes is combined with a molecular diagnostic reagent of a set of molecular diagnostic reagents. In the second variation of Step S450, the set of molecular diagnostic reagents preferably comprises different molecular diagnostic reagents, such that different molecular diagnostic protocols analyzing different markers may be performed. Thus, the second variation encompasses running multiple substantially different tests using a stock biological sample, and running substantially different tests using substantially different biological samples (e.g., from different sources)

[00114] In a specific example of Step S450, a multichannel liquid handling system aspirates approximately 18 μ L of each of a set of nucleic acid volumes from the microfluidic cartridge used in the specific example of Step S440 using a set of pipette tips, punctures at least one foil seal 195 of at least one assay strip, wherein each well of the at least one assay strip contains molecular diagnostic reagents, and dispenses each aspirated nucleic acid volume into a well of the assay strip. In the specific example of S450, the multichannel liquid handling system then aspirates and dispenses the contents of each well approximately 10 times to reconstitute molecular diagnostic reagents and mix the contents of each well.

[00115] Step S460 recites transferring each of the set of nucleic acid-reagent mixtures, through the corresponding fluidic pathway of the set of fluidic pathways, to

a detection chamber of a set of detection chambers, which functions to deliver the set of nucleic acid-reagent mixtures to an isolated detection chamber for further processing and analysis. Preferably, all nucleic acid-reagent mixtures in the set of nucleic acid-reagent mixtures are transferred simultaneously to the set of fluidic pathways, but alternatively, each nucleic acid-reagent mixture in the set of nucleic acid reagent mixtures may be transferred to a corresponding fluidic pathway independently of the other nucleic acid reagent mixtures. Step S460 may further comprise occluding at least one fluidic pathway of the set of fluidic pathways at a subset of a set of occlusion positions S462, which functions to define at least one truncated fluidic pathway coupled to a detection chamber of a set of detection chambers. Preferably, Step S462 comprises occluding each fluidic pathway of the set of fluidic pathways at a subset of a set of occlusion positions, thus defining a set of truncated fluidic pathways, each coupled to a detection chamber.

[00116] In a specific example of Step S460, the multichannel liquid handling subsystem of the specific example of Step S450 transfers a set of nucleic acid-reagent mixtures, each having a volume of approximately 16 μ L, back to the set of fluidic pathways of the microfluidic cartridge of the specific example of Step S450. Each nucleic acid-reagent mixture in the set of nucleic acid-reagent mixtures is transferred at a rate of 50 μ L/minute. Manipulation of the elastomeric layer at a subset of a set of occlusion positions by the valve actuation subsystem of the molecular diagnostic module defines a set of truncated fluidic pathways, each coupled to a detection chamber, such that each nucleic acid-magnetic bead sample in the set of nucleic acid-magnetic bead samples is isolated within a truncated fluidic pathway of the set of truncated fluidic pathways. In the specific embodiment the occlusion position immediately upstream of the detection chamber and the occlusion position immediately downstream of the detection chamber are normally closed positions. During delivery, the multichannel liquid handling subsystem generates pressure to cause the elastomeric layer at the normally closed positions to deform and allow fluid to flow through the normally closed positions. Once the pressure drops after the detection chamber is filled and the multichannel liquid handling subsystem ceases delivery, the elastomeric layer is configured to overcome the pressure in the channel and recloses, thereby sealing the normally closed positions. The normally closed positions are then compressed using the valve actuation subsystem during

thermocycling to prevent pressures generated during a molecular diagnostic assay to cause the normally closed positions to leak. After the molecular diagnostic assay is complete and the occlusion “pins” withdrawn, the normally closed positions allow the samples and amplicons to be trapped within detection chambers, substantially reducing the risk of contamination of the lab or other samples.

[00117] Step S470 recites receiving light from the set of nucleic acid-reagent mixtures, and functions to produce emission responses from the set of nucleic acid-reagent mixtures in response to transmission of excitation wavelength light or chemiluminescent effects. Preferably, Step S470 comprises the ability to transmit light including a wide range of wavelengths through a set of excitation filters and through a set of apertures configured to individually transmit light having single or multiple excitation wavelengths onto the set of nucleic acid-reagent mixtures, and receiving light through a set of emission filters, from the set of nucleic acid-reagent mixtures. Step S470 may additionally comprise reflecting light from the set of excitation filters off of a set of dichroic mirrors, and transmitting light through the set of dichroic mirrors to a set of photodetectors. A specific example of Step S470 comprises using the optical subsystem 180 of the system 100 described above to transmit and receive light; however, alternative variations of Step S470 may use any appropriate optical system configured to transmit light at excitation wavelengths toward the set of nucleic acid-reagent mixtures, and to receive light at emission wavelengths from the set of nucleic acid-reagent mixtures.

[00118] Step S480 recites generating a set of data based on light received from the set of nucleic acid-reagent mixtures, which functions to produce quantitative and/or qualitative data from the set of nucleic acid-reagent mixtures. Step S480 may further function to enable detection of a specific nucleic acid sequence from the nucleic acid-reagent mixture, in order to identify a specific nucleic acid sequence, gene, or organism. Preferably, Step S480 includes converting electrical signals, produced by a set of photodetectors upon receiving light from the set of nucleic acid-reagent mixtures, into a quantifiable metric; however, S480 may alternatively comprise converting electromagnetic energy, received by a set of photodetectors from the set of nucleic acid-reagent mixtures, into a set of qualitative data. In one variation of Step S480, the set of data may be processed by a processor and rendered

on a user interface; however, in other variations of Step S480, the set of data may alternatively not be rendered on a user interface.

[00119] The method 400 may further comprise re-running a biological sample S490 if processing and/or analysis of the biological sample results in less than ideal results. Preferably, Step S490 occurs if an analysis of a biological sample is indeterminate due to machine or user error. Additionally, Step S490 preferably occurs automatically upon detection of a less than ideal result, but may alternatively occur in response to a user prompt.

[00120] Embodiments of the method 400 and variations thereof can be embodied and/or implemented at least in part by a machine configured to receive a computer-readable medium storing computer-readable instructions. The instructions are preferably executed by computer-executable components preferably integrated with the system 100 and one or more portions of the processor 273 and/or the controller 272. The computer-readable medium can be stored on any suitable computer-readable media such as RAMs, ROMs, flash memory, EEPROMs, optical devices (CD or DVD), hard drives, floppy drives, or any suitable device. The computer-executable component is preferably a general or application specific processor, but any suitable dedicated hardware or hardware/firmware combination device can alternatively or additionally execute the instructions.

[00121] The FIGURES illustrate the architecture, functionality and operation of possible implementations of systems, methods and computer program products according to preferred embodiments, example configurations, and variations thereof. In this regard, each block in the flowchart or block diagrams may represent a module, segment, or portion of code, which comprises one or more executable instructions for implementing the specified logical function(s). It should also be noted that, in some alternative implementations, the functions noted in the block can occur out of the order noted in the FIGURES. For example, two blocks shown in succession may, in fact, be executed substantially concurrently, or the blocks may sometimes be executed in the reverse order, depending upon the functionality involved. It will also be noted that each block of the block diagrams and/or flowchart illustration, and combinations of blocks in the block diagrams and/or flowchart illustration, can be implemented by special purpose hardware-based systems that

perform the specified functions or acts, or combinations of special purpose hardware and computer instructions.

[00122] As a person skilled in the art will recognize from the previous detailed description and from the figures and claims, modifications and changes can be made to the preferred embodiments of the invention without departing from the scope of this invention defined in the following claims.

CLAIMS

We claim:

1. A system for processing and detecting nucleic acids, comprising:
 - a capture plate comprising at least one well configured to facilitate a combination of a set of magnetic beads with a biological sample, thus producing a magnetic bead-sample; and
 - a molecular diagnostic module, configured to process at least one magnetic bead-sample obtained from the capture plate, and separate nucleic acids from magnetic beads, wherein the molecular diagnostic module comprises:
 - a cartridge platform comprising a magnet receiving slot,
 - an actuator configured to displace the cartridge platform, and
 - a magnet, wherein an extended configuration of the actuator allows the magnet to pass through the magnet receiving slot to facilitate separation of the at least one nucleic acid volume.
2. The system of Claim 1, further comprising a liquid handling system configured to transfer at least one magnetic bead-sample from the capture plate to the molecular diagnostic module, and to aspirate at least one nucleic acid volume from the molecular diagnostic module.
3. The system of Claim 2, wherein the system is not configured to remove a supernatant from the capture plate prior to transfer of at least one magnetic bead-sample from the capture plate to the molecular diagnostic module.
4. The system of Claim 1, wherein the capture plate comprises a set of wells and a foil seal configured to seal each well of the set of wells, wherein each well in the set of wells contain a set of magnetic beads, a set of lysing reagents, and a sample process control,
5. The system of Claim 1, further comprising a capture plate module comprising a thermally conducting substrate configured to cradle at least one well of the capture plate, and a heater coupled to the thermally conducting substrate.
6. The system of Claim 1, wherein the actuator of the molecular diagnostic module is a linear actuator, configured to vertically displace the cartridge platform, and wherein the

cartridge platform of the molecular diagnostic module is coupled to a set of springs configured to counteract a force provided by the linear actuator.

7. The system of Claim 1, wherein a retracted configuration of the actuator allows the magnet to retract from the magnet receiving slot.

8. The system of Claim 1, wherein the magnet is configured to provide a magnetic field spanning at least three fluidic pathways configured to facilitate isolation and extraction of three nucleic acid volumes.

9. The system of Claim 1, wherein the magnet is at least one of an electromagnet and a permanent magnet.

10. The system of Claim 1, wherein the molecular diagnostic module further comprises a cam card contacting a set of pins, wherein an extended configuration of the actuator combined with movement of the cam card vertically displaces a subset of the set of pins through a set of slots of the cartridge platform, to define at least one distinct pathway configured to receive at least one magnetic bead-sample.

11. The system of Claim 1, further comprising an assay strip comprising at least one reagent well, each containing a molecular diagnostic reagent configured to be combined with a nucleic acid volume.

12. The system of Claim 9, wherein the molecular diagnostic module further comprises an optical subsystem comprising at least one unit, wherein each unit includes an excitation filter, an emission filter, a photodetector aligned with the emission filter, and a dichroic mirror configured to reflect light from the excitation filter toward one of three nucleic acid-reagent mixtures, and to transmit emitted light from one of the three nucleic acid-reagent mixtures, through the emission filter, and toward the photodetector.

13. The system of Claim 1, wherein the molecular diagnostic module further comprises a molecular diagnostic module heater configured to heat at least one magnetic bead-sample.

14. The system of Claim 1, wherein the molecular diagnostic module is configured receive and align a microfluidic cartridge comprising a set of sample port-reagent port pairs, a fluid port, a set of detection chambers, a waste chamber, an elastomeric layer, and a set of fluidic

pathways, wherein each fluidic pathway of the set of fluidic pathways is coupled to a sample port-reagent port pair, the fluid port, and a detection chamber, comprises a segment configured to cross the magnet, and is configured to transfer a waste fluid to the waste chamber, and to be occluded upon deformation of the elastomeric layer.

15. The system of Claim 1, wherein the liquid handling system comprises a multichannel pipette head and a syringe pump.

16. The system of Claim 15, wherein the syringe pump is coupled to a nozzle coupled to the actuator of the molecular diagnostic module.

17. A system for processing and detecting nucleic acids, comprising:

- a capture plate comprising at least one well containing a set of magnetic beads configured to be combined with a biological sample to produce a magnetic bead-sample;
- an assay strip comprising at least one well containing a molecular diagnostic reagent configured to be combined with a nucleic acid volume to produce a nucleic acid-reagent mixture;
- a molecular diagnostic module, configured to process the magnetic bead-sample from the capture plate, separate the nucleic acid volume from the magnetic bead-sample, and analyze the nucleic acid-reagent mixture from the assay strip; and
- a liquid handling system configured to transfer the magnetic bead-sample from the capture plate to the molecular diagnostic module, transfer the nucleic acid volume from the molecular diagnostic module to the assay strip, and transfer the nucleic acid-reagent mixture from the assay strip to the molecular diagnostic module.

18. The system of Claim 17, wherein the capture plate comprises a first foil seal configured to seal each well of the set of wells, and wherein the assay strip comprises a second foil seal, configured to seal each reagent well of the set of reagent wells.

19. The system of Claim 17, wherein the molecular diagnostic module comprises an optical subsystem comprising at least one unit, wherein each unit includes an excitation filter, an emission filter, a photodetector aligned with the emission filter, and a dichroic mirror configured to reflect light from the excitation filter toward the nucleic acid-reagent mixture, and to transmit light from the nucleic acid reagent mixture, through the emission filter, and toward the photodetector wherein each unit of the optical subsystem further

comprises an LED aligned with the excitation filter, wherein the LED provides multiple wavelengths of light corresponding to at least one of the excitation filter, the dichroic mirror, and the emission filter.

20. The system of Claim 17, wherein the molecular diagnostic module further comprises a heater and a detection chamber heater, wherein the heater is configured to heat the magnetic bead-sample, and wherein the detection chamber heater is configured to individually heat the nucleic acid-reagent mixture, and wherein at least one of the heater and the detection chamber heater is a Peltier heater.

21. The system of Claim 19, wherein the molecular diagnostic module further comprises a linear actuator coupled to the optical subsystem, such that an extended configuration of the linear actuator vertically displaces the optical subsystem.

22. The system of Claim 21, wherein the molecular diagnostic module further comprises a cartridge platform including a set of parallel slots, and comprises a magnet, a cam card, and a set of pins contacting the cam card, wherein an extended configuration of the linear actuator allows a parallel slot of the cartridge platform to pass over the magnet, and wherein an extended configuration of the linear actuator combined with movement of the cam card vertically displaces a subset of the set of pins through a subset of the set of parallel slots to define at least one pathway configured to receive the magnetic bead-sample.

23. The system of Claim 17, wherein the liquid handling system comprises a multichannel pipette head and a syringe pump.

24. The system of Claim 23, wherein the syringe pump is coupled to a nozzle coupled to the actuator of the molecular diagnostic module.

25. A system for processing and detecting nucleic acids, comprising:

- a molecular diagnostic module, configured to process a set of biological samples combined with magnetic beads and separate a set of nucleic acid volumes from the set of biological samples combined with magnetic beads, wherein the molecular diagnostic module comprises an actuator configured to displace a cartridge, a set of pins, and at least one cam contacting the set of pins, wherein an extension or retraction of the actuator moves the cartridge, and a displacement of a subset of the set of pins defines a set of pathways in the cartridge, each configured to receive a

biological sample combined with magnetic beads of the set of biological samples combined with magnetic beads.

26. The system of Claim 25, further comprising:
- a capture plate comprising at least one well containing a set of magnetic beads configured to be combined with a biological sample, a lysing reagent, and a sample process control, wherein the capture plate facilitates production of at least one biological sample combined with magnetic beads;
 - an assay strip comprising at least one reagent well containing a molecular diagnostic reagent volume configured to be combined with a nucleic acid volume of the set of nucleic acid volumes to produce at least one nucleic acid-reagent mixture; and
 - a liquid handling system configured to transfer at least one biological sample combined with magnetic beads from the capture plate to the molecular diagnostic module, transfer at least one nucleic acid volume from the molecular diagnostic module to the assay strip, and transfer at least one nucleic acid-reagent mixture from the assay strip back to the molecular diagnostic module.
27. The system of Claim 25, wherein the actuator of the molecular diagnostic module is a linear actuator, configured to vertically displace the cartridge.
28. The system of Claim 25, wherein the cartridge of the molecular diagnostic module contacts a cartridge platform coupled to a set of springs configured to counteract a force provided by the linear actuator.
29. The system of Claim 28, further comprising a pin housing configured to house the set of pins and to guide the set of pins through a set of slots of the cartridge platform.
30. The system of Claim 29, wherein at least one pin in the set of pins has a first diameter and a second diameter, different from the first diameter, such that the first diameter and the second diameter are configured to limit motion of the at least one pin through the pin housing.
31. The system of Claim 30, wherein at least one pin in the set of pins includes a spring configured to counteract a force provided by the cam.

32. The system of Claim 25, wherein the cam is a cam card is coupled to a cam card actuator configured to linearly displace the cam card under the set of pins.
33. The system of Claim 32, wherein the cam card comprises a fixed set of hills and valleys, such that a pin of the set of pins is raised when a hill of the cam card passes under the pin, and a pin of the set of pins is lowered when a valley of the cam card passes under the pin.
34. The system of Claim 26, wherein the liquid handling system comprises a multichannel pipette head and a syringe pump.
35. A method for processing and detecting nucleic acids from a biological sample, with a cartridge including a fluidic pathway coupled to a sample port and a reagent port, wherein the method comprises:
- dispensing the biological sample into the fluidic pathway through the sample port of the cartridge;
 - separating a volume of nucleic acids from the biological sample within a first portion of the fluidic pathway;
 - removing at least a portion of the volume of nucleic acids from the fluidic pathway through the reagent port or the sample port of the cartridge;
 - combining the portion of the volume of nucleic acids with a molecular diagnostic reagent to produce a nucleic acid-reagent mixture; and
 - delivering the nucleic acid-reagent mixture through a second portion of the fluidic pathway to a detection chamber.
36. The method of Claim 35, further comprising combining the biological sample with a quantity of magnetic beads, to produce a magnetic bead-sample mixture, prior to dispensing the biological sample into the fluidic pathway through the sample port.
37. The method of Claim 36, wherein combining the biological sample with a quantity of magnetic beads further comprises heating the biological sample with the quantity of magnetic beads.
38. The method of Claim 36, wherein a supernatant is not removed from the magnetic bead-sample mixture prior to dispensing the biological sample into the fluidic pathway.

39. The method of Claim 36, wherein separating a volume of nucleic acids from the biological sample comprises providing a magnetic field at the first portion of the fluidic pathway to capture the magnetic bead-sample within the first portion of the fluidic pathway.
40. The method of Claim 39, wherein separating a volume of nucleic acids from the biological sample further comprises dispensing a wash solution through the first portion of the fluidic pathway by a fluid port coupled to the fluidic pathway.
41. The method of Claim 40, wherein separating a volume of nucleic acids from the biological sample further comprises dispensing a release solution through the fluidic pathway by the fluid port.
42. The method of Claim 41, wherein separating a volume of nucleic acids from the biological sample further comprises heating the first portion of the fluidic pathway to facilitate a pH shift, thus releasing unbinding nucleic acids from magnetic beads to produce the volume of nucleic acids.
43. The method of Claim 35, wherein combining the portion of the volume of nucleic acids with a molecular diagnostic reagent to produce a nucleic acid-reagent mixture comprises aspirating the nucleic acid-reagent mixture from a well and delivering the nucleic acid-reagent mixture into the well multiple times.
44. The method of Claim 35, wherein delivering the nucleic acid-reagent mixture through a second portion of the fluidic pathway comprises delivering the nucleic acid-reagent mixture through the reagent port of the cartridge.
45. The method of Claim 35, further comprising generating a set of data based on and receiving light from the nucleic acid-reagent mixture through an emission filter.
46. The method of Claim 45, wherein generating a set of data further comprises detecting a specific nucleic acid sequence from the nucleic acid-reagent mixture within the detection chamber for identifying a specific nucleic acid sequence or nucleic acid sequences.
47. The method of Claim 35, wherein delivering the nucleic acid-reagent mixture through a second portion of the fluidic pathway to a detection chamber comprises delivering the

nucleic acid-reagent mixture through a second portion of a fluidic pathway of a second cartridge.

48. The method of Claim 35, wherein at least one of dispensing, separating, removing, combining, and delivering is automatically re-performed for the biological sample in response to an indeterminate result.

49. A method for processing and detecting nucleic acids from a set of biological samples, comprising:

- combining each biological sample of the set of biological samples with a quantity of magnetic beads to produce a set of nucleic acid-magnetic bead samples;
- transferring substantially all of each nucleic acid-magnetic bead sample of the set of nucleic acid-magnetic bead samples to a corresponding fluidic pathway of a set of fluidic pathways; and
- detecting nucleic acids using a set of detection chambers coupled to the set of fluidic pathways.

50. The method of Claim 49, wherein the method for processing and detecting nucleic acids from a set of biological samples comprises processing and detecting nucleic acids from identical portions of a stock biological sample, such that all biological samples in the set of biological samples are substantially identical in composition.

51. The method of Claim 49, wherein combining each biological sample of the set of biological samples with a quantity of magnetic beads to produce a set of nucleic acid-magnetic bead samples further comprises heating the set of nucleic acid-magnetic bead samples.

52. The method of Claim 49, wherein combining each biological sample of the set of biological samples with a quantity of magnetic beads comprises combining each biological sample of the set of biological samples with a quantity of magnetic beads treated to be at least one of positively charged, magnetic, paramagnetic, and supraparamagnetic.

53. The method of Claim 49, further comprising producing a set of nucleic acid volumes from the set of nucleic acid-magnetic bead samples, prior to detecting nucleic acids using a set of detection chambers.

54. The method of Claim 53, wherein producing a set of nucleic acid volumes from the set of nucleic acid-magnetic bead samples comprises:

- providing a magnetic field spanning a portion of each fluidic pathway in the set of fluidic pathways, thus capturing the set of nucleic acid-magnetic bead samples;
- dispensing a wash solution into each fluidic pathway of the set of fluidic pathways;
- dispensing a release solution into each fluidic pathway of the set of fluidic pathways; and
- heating each fluidic pathway of the set of fluidic pathways to facilitate a pH shift, thus unbinding nucleic acids from magnetic beads to produce the set of nucleic acid volumes.

55. The method of Claim 54, wherein dispensing a wash solution and dispensing a release solution comprises dispensing a wash solution and dispensing a release solution into a fluid port, wherein the fluid port is coupled to each fluidic pathway in the set of fluidic pathways.

56. The method of Claim 55, further comprising coupling the fluid port to an external fluid handling system.

57. The method of Claim 53, further comprising combining each nucleic acid volume of the set of d nucleic acid volumes with a molecular diagnostic reagent of a set of molecular diagnostic reagents prior to detecting nucleic acids using a set of detection chambers.

58. The method of Claim 57, wherein all molecular diagnostic reagents of the set of molecular diagnostic reagents are configured to facilitate identical assays.

59. The method of Claim 50, further comprising producing a set of nucleic acid volumes from the stock biological sample, and combining the set of nucleic acid volumes with a set of molecular diagnostic reagents, to facilitate running multiple assays from the stock biological sample.

60. The method of Claim 53, further comprising aspirating the set of nucleic acid volumes from the set of fluidic pathways, wherein aspirating comprises aspirating the set of nucleic acid volumes from a set of reagent ports, wherein each reagent port of the set of reagent ports is coupled to a corresponding fluidic pathway of the set of fluidic pathways.

61. The method of Claim 60, further comprising transferring each of the set of nucleic acid-reagent mixtures into the corresponding fluidic pathway of the set of fluidic pathways, wherein transferring comprises transferring the set of nucleic acid-reagent mixtures back into the set of reagent ports.

62. The method of Claim 53, further comprising transmitting light through a set of excitation filters toward the set of nucleic acid-reagent mixtures within the set of detection chambers, and receiving light from the set of nucleic acid-reagent mixtures through a set of emission filters.

63. A method for processing and detecting nucleic acids within a fluidic pathway including a set of occlusion positions, comprising:

- occluding the fluidic pathway at a first subset of the set of occlusion positions, thus defining a first truncated fluidic pathway passing through a magnetic field;
- capturing a sample of nucleic acids bound to magnetic beads within the first truncated fluidic pathway, by the magnetic field; and
- occluding the fluidic pathway at a second subset of the set of occlusion positions, thus defining a second truncated fluidic pathway containing the sample of nucleic acids bound to magnetic beads.

64. The method of Claim 63, further comprising:

- delivering a wash solution into the second truncated fluidic pathway through a fluid port to facilitate production of a volume of nucleic acids
- delivering the volume of nucleic acids through a reagent port coupled to the fluidic pathway;
- receiving the volume of nucleic acids combined with a volume of molecular diagnostic reagents to produce a nucleic acid-reagent sample;
- occluding the fluidic pathway at a third subset of the set of occlusion positions, thus defining a third truncated fluidic pathway coupled to a detection chamber; and
- delivering the nucleic acid-reagent sample, through the third truncated fluidic pathway, to the detection chamber.

65. The method of Claim 63, wherein occluding the fluidic pathway comprises occluding the fluidic pathway using a cam card contacting to a set of pins, wherein lateral movement of the cam card vertically displaces a subset of the set of pins.
66. The method of Claim 64, wherein delivering a wash solution comprises delivering a wash solution using a syringe pump.
67. The method of Claim 64, wherein at least one of delivering the volume of nucleic acids and delivering the nucleic acid-reagent sample comprises delivering using a multichannel pipette head.
68. The method of Claim 64, further comprising:
- occluding the fluidic pathway at a fourth subset of the set of occlusion positions, thus defining a fourth truncated fluidic pathway containing the sample of nucleic acids bound to magnetic beads and coupled to the fluid port, and
 - delivering a release solution into the fourth truncated fluidic pathway through the fluid port to facilitate production of the volume of nucleic acids.
69. The method of Claim 64, wherein delivering the nucleic acid-reagent sample to the detection chamber comprises delivering the nucleic acid-reagent sample through the reagent port.

AMENDED CLAIMS**received by the International Bureau on 19 June 2013 (19.06.2013)**

1. A system for processing and detecting nucleic acids, comprising:
 - a capture plate comprising at least one well configured to facilitate a combination of a set of magnetic beads with a biological sample, thus producing a magnetic bead-sample; and
 - a molecular diagnostic module, configured to process at least one magnetic bead-sample obtained from the capture plate, and separate nucleic acids from magnetic beads, wherein the molecular diagnostic module comprises:
 - a cartridge platform comprising a magnet receiving slot,
 - an actuator configured to displace the cartridge platform, and
 - a magnet, wherein an extended configuration of the actuator allows the magnet to pass through the magnet receiving slot to facilitate separation of the at least one nucleic acid volume.
2. The system of Claim 1, wherein the system is not configured to remove a supernatant from the capture plate prior to transfer of at least one magnetic bead-sample from the capture plate to the molecular diagnostic module.
3. The system of Claim 1, wherein the molecular diagnostic module further comprises a cam card contacting a set of pins, wherein an extended configuration of the actuator combined with movement of the cam card vertically displaces a subset of the set of pins through a set of slots of the cartridge platform, to define at least one distinct pathway configured to receive at least one magnetic bead-sample.
4. The system of Claim 1, wherein the molecular diagnostic module is configured receive and align a microfluidic cartridge comprising a set of sample port-reagent port pairs, a fluid port, a set of detection chambers, a waste chamber, an elastomeric layer, and a set of fluidic pathways, wherein each fluidic pathway of the set of fluidic pathways is coupled to a sample port-reagent port pair, the fluid port, and a detection chamber, comprises a segment configured to cross the magnet, and is configured to transfer a waste fluid to the waste chamber, and to be occluded upon deformation of the elastomeric layer.
5. A system for processing and detecting nucleic acids, comprising:
 - a capture plate comprising at least one well containing a set of magnetic beads configured to be combined with a biological sample to produce a magnetic bead-sample;

- an assay strip comprising at least one well containing a molecular diagnostic reagent configured to be combined with a nucleic acid volume to produce a nucleic acid-reagent mixture;
 - a molecular diagnostic module, configured to process the magnetic bead-sample from the capture plate, separate the nucleic acid volume from the magnetic bead-sample, and analyze the nucleic acid-reagent mixture from the assay strip; and
 - a liquid handling system configured to transfer the magnetic bead-sample from the capture plate to the molecular diagnostic module, transfer the nucleic acid volume from the molecular diagnostic module to the assay strip, and transfer the nucleic acid-reagent mixture from the assay strip to the molecular diagnostic module.
6. The system of Claim 1 or 5, wherein the molecular diagnostic module comprises an optical subsystem comprising at least one unit comprising an excitation filter, an emission filter, a photodetector aligned with the emission filter, and a dichroic mirror configured to reflect light from the excitation filter toward the nucleic acid-reagent mixture, and to transmit light from the nucleic acid reagent mixture, through the emission filter, and toward the photodetector.
7. A system for processing and detecting nucleic acids, comprising:
- a molecular diagnostic module, configured to process a set of biological samples combined with magnetic beads and separate a set of nucleic acid volumes from the set of biological samples combined with magnetic beads, wherein the molecular diagnostic module comprises an actuator configured to displace a cartridge, a set of pins, and at least one cam contacting the set of pins, wherein an extension or retraction of the actuator moves the cartridge, and a displacement of a subset of the set of pins defines a set of pathways in the cartridge, each configured to receive a biological sample combined with magnetic beads of the set of biological samples combined with magnetic beads.
8. The system of Claim 7, further comprising:
- a capture plate comprising at least one well containing a set of magnetic beads configured to be combined with a biological sample, a lysing reagent, and a sample process control, wherein the capture plate facilitates production of at least one biological sample combined with magnetic beads;

- an assay strip comprising at least one reagent well containing a molecular diagnostic reagent volume configured to be combined with a nucleic acid volume of the set of nucleic acid volumes to produce at least one nucleic acid-reagent mixture; and
- a liquid handling system configured to transfer at least one biological sample combined with magnetic beads from the capture plate to the molecular diagnostic module, transfer at least one nucleic acid volume from the molecular diagnostic module to the assay strip, and transfer at least one nucleic acid-reagent mixture from the assay strip back to the molecular diagnostic module.

9. The system of Claim 7, wherein the cam comprises a fixed set of hills and valleys, such that a pin of the set of pins is raised when a hill of the cam displaces the pin, and a pin of the set of pins is lowered when a valley of the cam displaces the pin.

10. A method for processing and detecting nucleic acids from a biological sample, with a cartridge including a fluidic pathway coupled to a sample port and a reagent port, wherein the method comprises:

- dispensing the biological sample into the fluidic pathway through the sample port of the cartridge;
- separating a volume of nucleic acids from the biological sample within a first portion of the fluidic pathway;
- removing at least a portion of the volume of nucleic acids from the fluidic pathway through the reagent port or the sample port of the cartridge;
- combining the portion of the volume of nucleic acids with a molecular diagnostic reagent to produce a nucleic acid-reagent mixture; and
- delivering the nucleic acid-reagent mixture through a second portion of the fluidic pathway to a detection chamber.

11. The method of Claim 10, further comprising combining the biological sample with a quantity of magnetic beads, to produce a magnetic bead-sample mixture, prior to dispensing the biological sample into the fluidic pathway through the sample port, and wherein a supernatant is not removed from the magnetic bead-sample mixture prior to dispensing the biological sample into the fluidic pathway.

12. The method of Claim 11, wherein separating a volume of nucleic acids from the biological sample comprises providing a magnetic field at the first portion of the fluidic pathway to capture the magnetic bead-sample within the first portion of the fluidic pathway.
13. The method of Claim 10, further comprising generating a set of data based upon and receiving light from the nucleic acid-reagent mixture through an emission filter, and wherein generating a set of data further comprises detecting a specific nucleic acid sequence from the nucleic acid-reagent mixture within the detection chamber for identifying a specific nucleic acid sequence or nucleic acid sequences.
14. The method of Claim 10, wherein delivering the nucleic acid-reagent mixture through a second portion of the fluidic pathway to a detection chamber comprises delivering the nucleic acid-reagent mixture through a second portion of a fluidic pathway of a second cartridge.
15. The method of Claim 10, wherein at least one of dispensing, separating, removing, combining, and delivering is automatically re-performed for the biological sample in response to an indeterminate result.
16. A method for processing and detecting nucleic acids from a set of biological samples, comprising:
- combining each biological sample of the set of biological samples with a quantity of magnetic beads in a first set of vessels to produce a set of nucleic acid-magnetic bead samples;
 - transferring substantially all of each nucleic acid-magnetic bead sample of the set of nucleic acid-magnetic bead samples from the first set of vessels to a corresponding fluidic pathway of a set of fluidic pathways;
 - producing a set of nucleic acid volumes from the set of nucleic acid-magnetic bead samples wherein producing comprises dispensing a release solution into each fluidic pathway of the set of fluidic pathways; and
 - detecting nucleic acids from the set of nucleic acid volumes using a set of detection chambers coupled to the set of fluidic pathways.
17. The method of Claim 16, wherein the method for processing and detecting nucleic acids from a set of biological samples comprises processing and detecting nucleic acids from identical

portions of a stock biological sample, such that all biological samples in the set of biological samples are substantially identical in composition.

18. The method of Claim 16, further comprising aspirating the set of nucleic acid volumes from the set of fluidic pathways, wherein aspirating comprises aspirating the set of nucleic acid volumes from a set of reagent ports, wherein each reagent port of the set of reagent ports is coupled to a corresponding fluidic pathway of the set of fluidic pathways.

19. A method for processing and detecting nucleic acids within a fluidic pathway including a set of occlusion positions, comprising:

- occluding the fluidic pathway at a first subset of the set of occlusion positions, thus defining a first truncated fluidic pathway passing through a magnetic field;
- capturing a sample of nucleic acids bound to magnetic beads within the first truncated fluidic pathway, by the magnetic field;
- occluding the fluidic pathway at a second subset of the set of occlusion positions, thus defining a second truncated fluidic pathway containing the sample of nucleic acids bound to magnetic beads;
- delivering a release solution into the second truncated fluidic pathway through a fluid port to facilitate production of a volume of nucleic acids; and
- delivering the volume of nucleic acids to a detection chamber.

20. The method of Claim 19, further comprising:

- delivering a wash solution into the second truncated fluidic pathway through a fluid port to facilitate production of a volume of nucleic acids;
- delivering the volume of nucleic acids through a reagent port coupled to the fluidic pathway;
- receiving the volume of nucleic acids combined with a volume of molecular diagnostic reagents to produce a nucleic acid-reagent sample;
- occluding the fluidic pathway at a third subset of the set of occlusion positions, thus defining a third truncated fluidic pathway coupled to a detection chamber;
- delivering the nucleic acid-reagent sample, through the third truncated fluidic pathway, to the detection chamber;

- occluding the fluidic pathway at a fourth subset of the set of occlusion positions, thus defining a fourth truncated fluidic pathway containing the sample of nucleic acids bound to magnetic beads and coupled to the fluid port, and
- delivering a release solution into the fourth truncated fluidic pathway through the fluid port to facilitate production of the volume of nucleic acids.

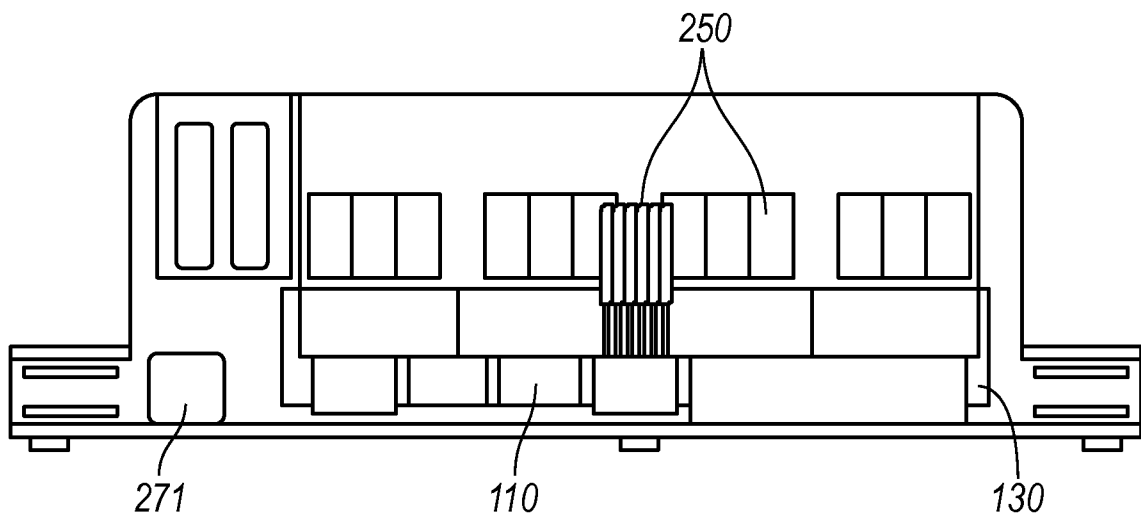
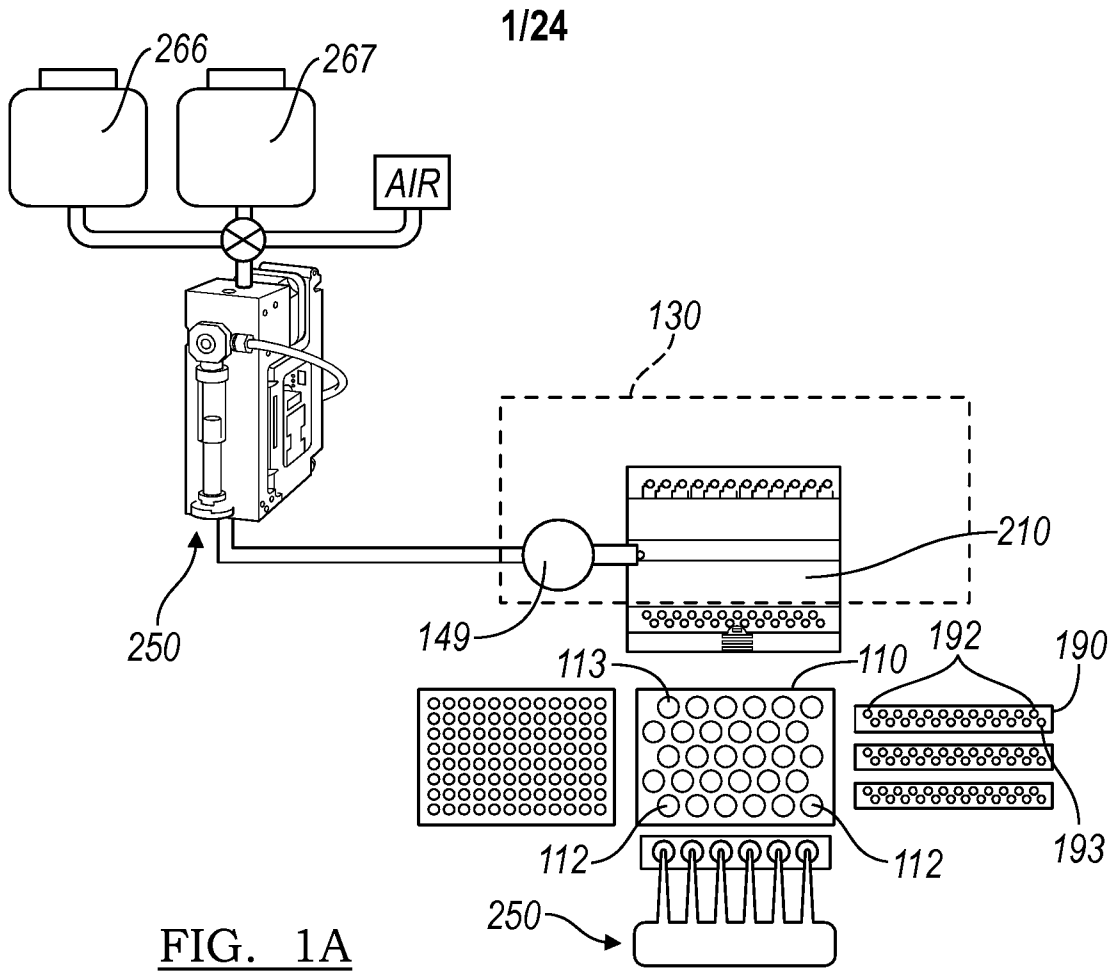

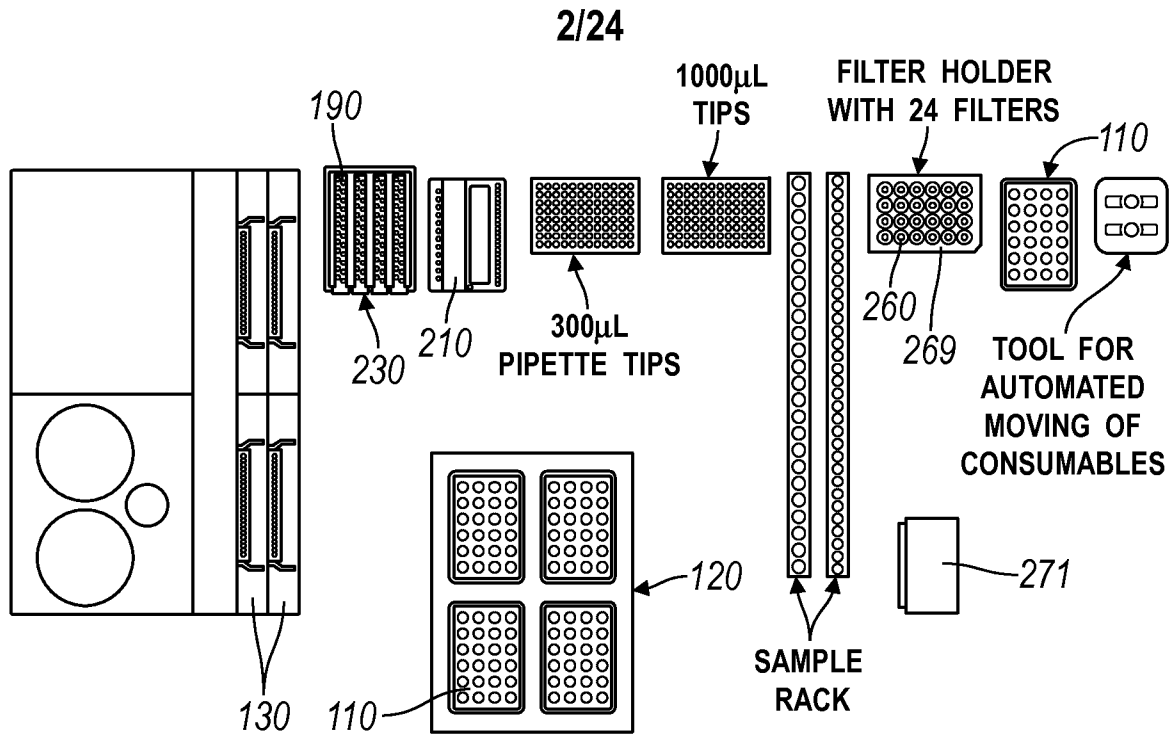

FIG. 2A

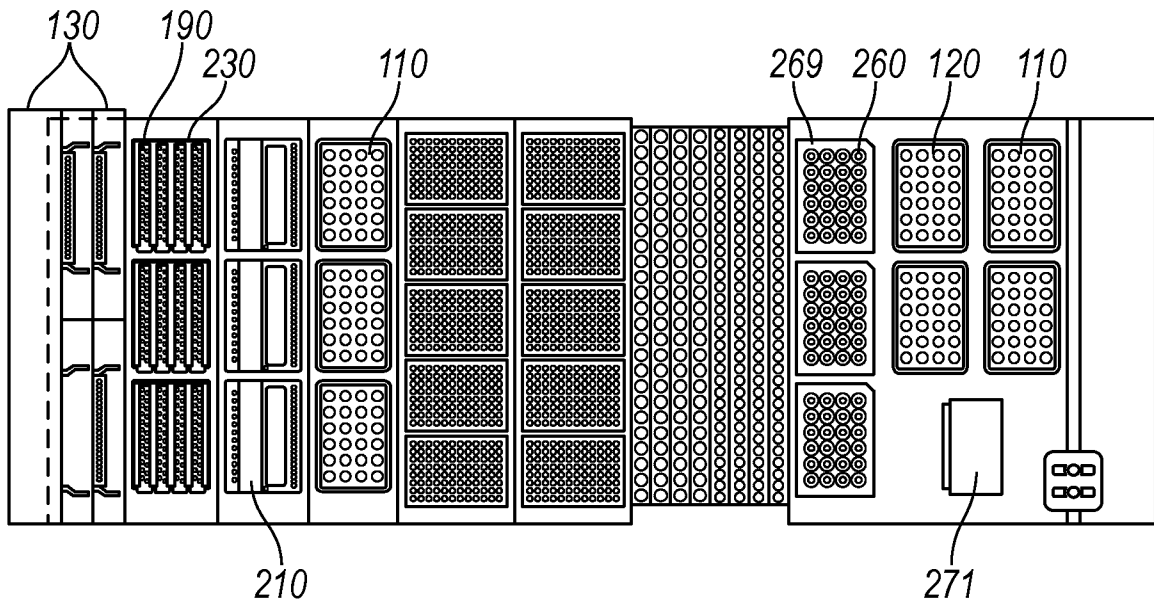

FIG. 2B

3/24

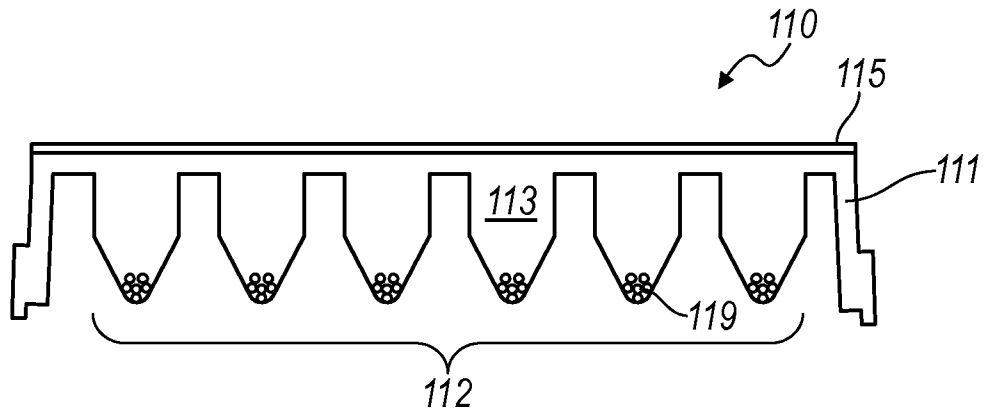

FIG. 3A

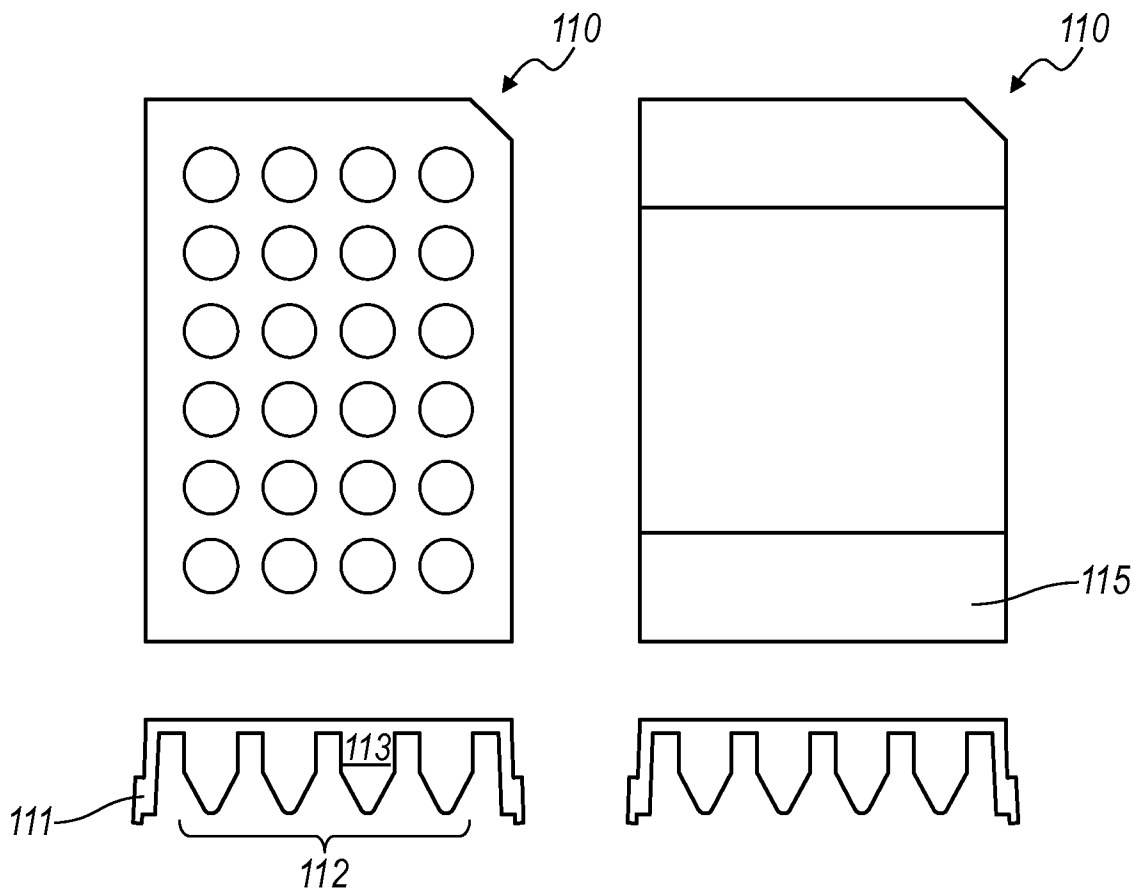
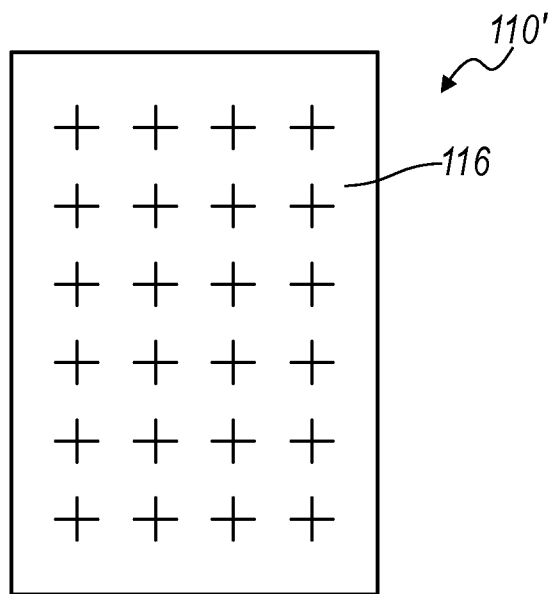
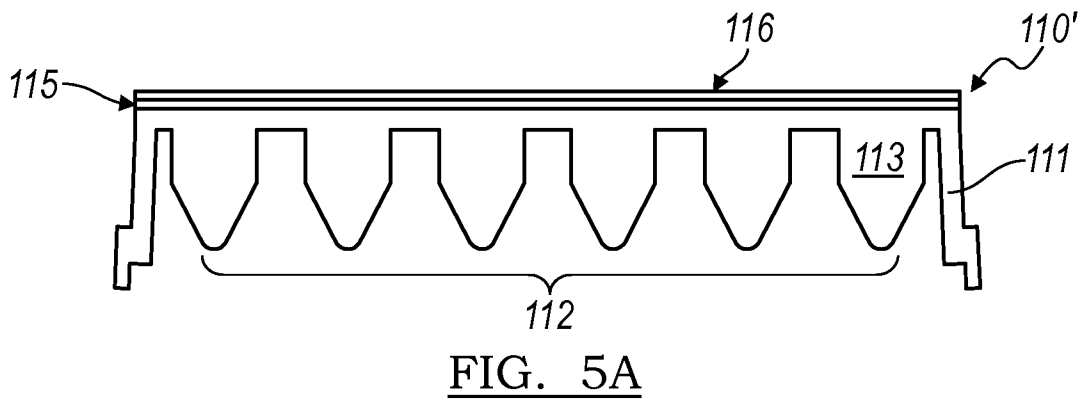
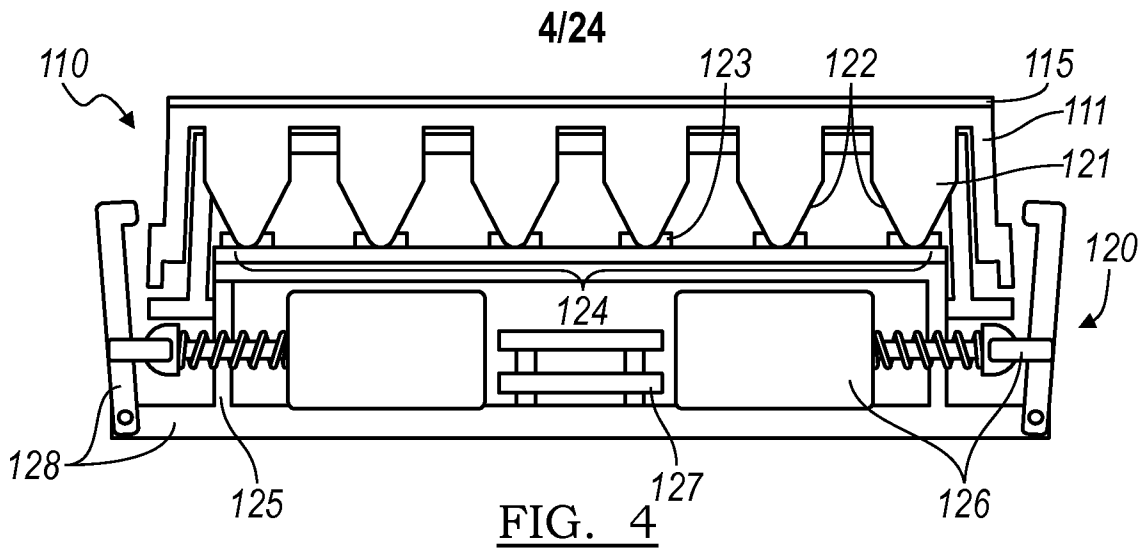
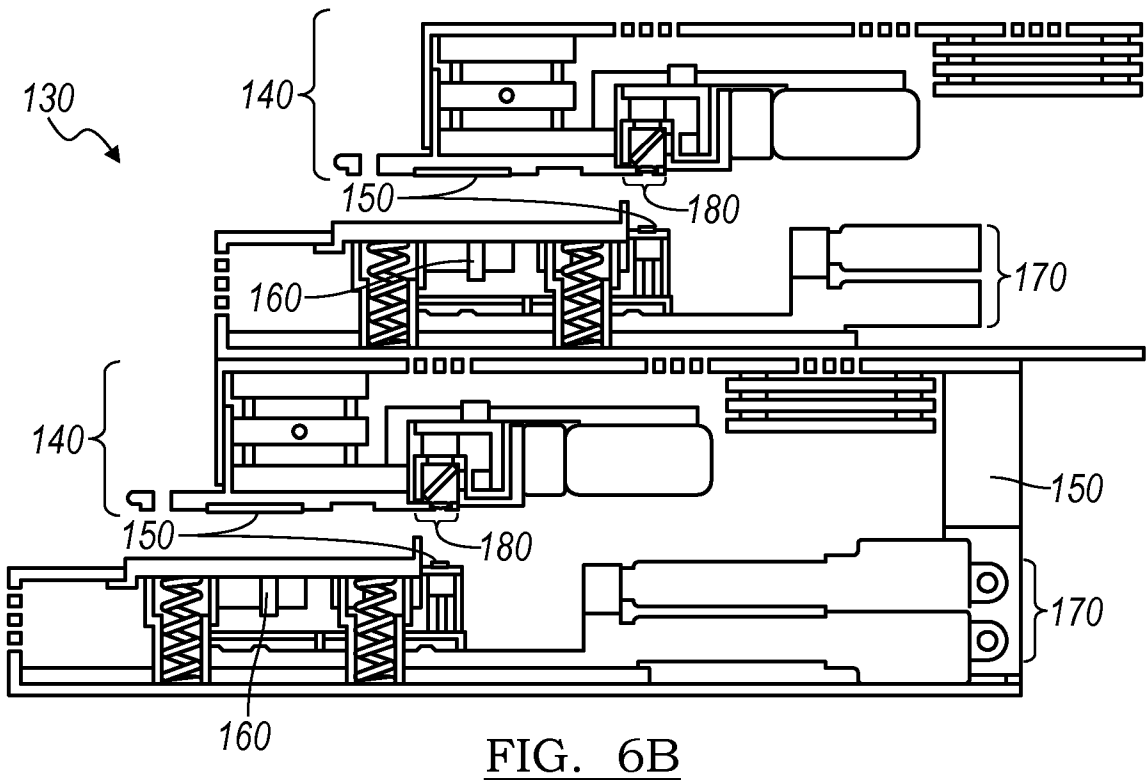
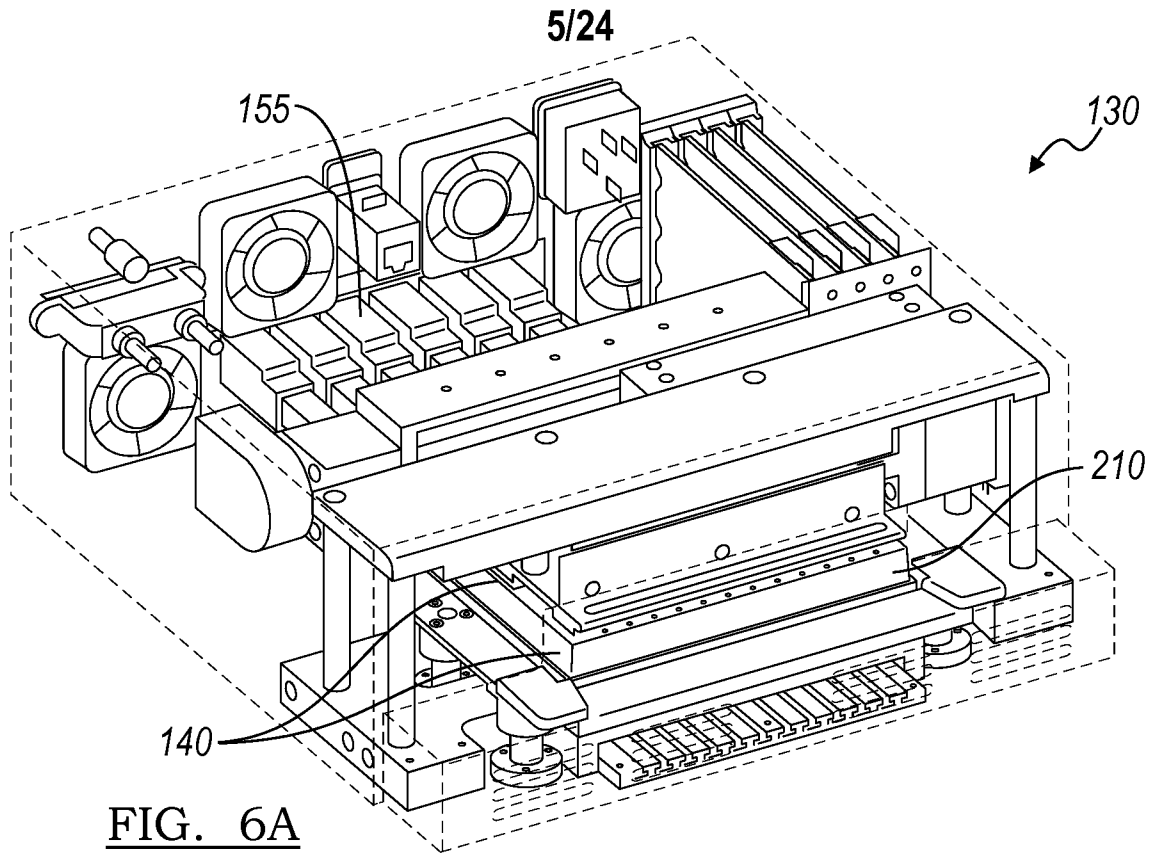

FIG. 3B





6/24

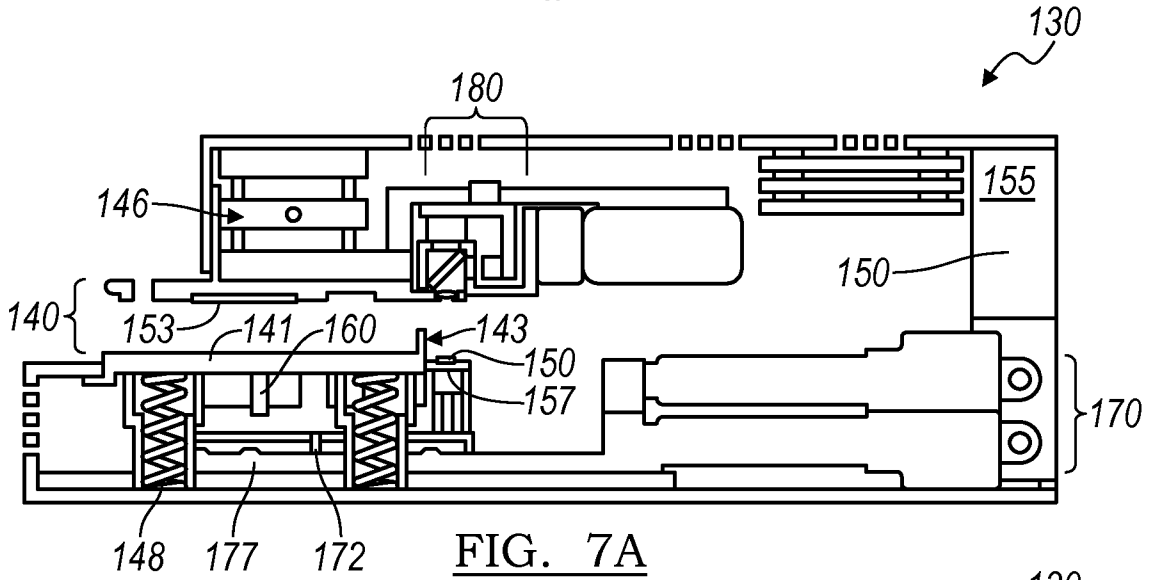

FIG. 7A

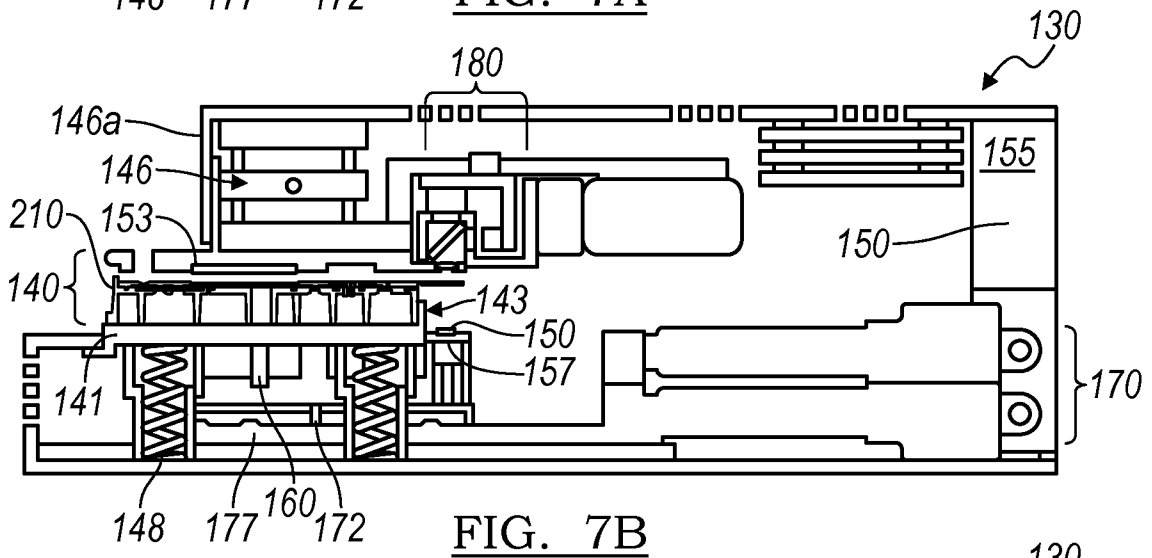

FIG. 7B

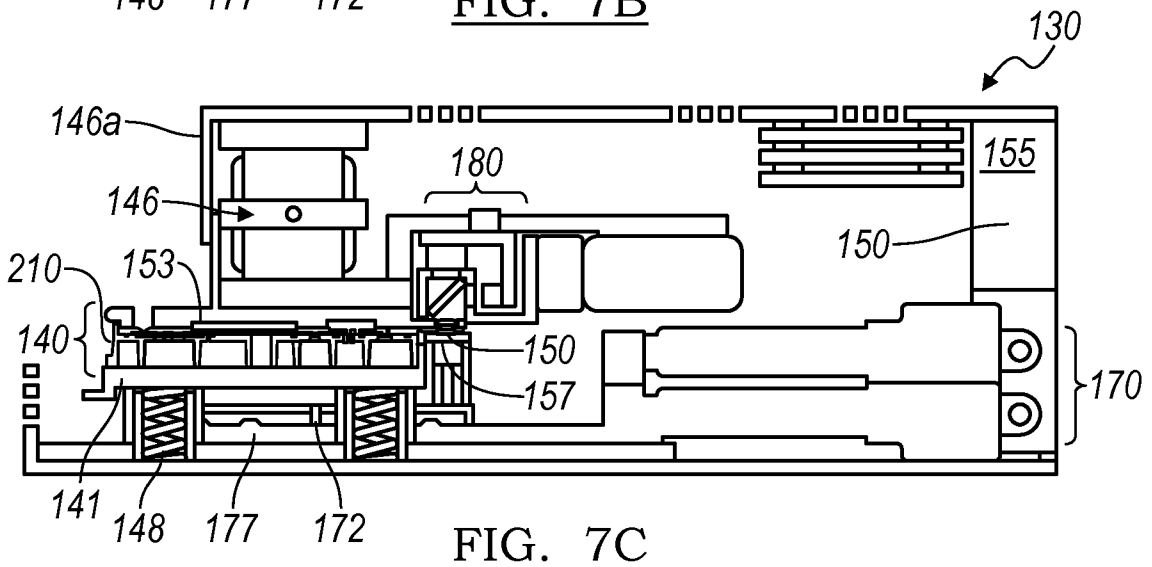

FIG. 7C

7/24

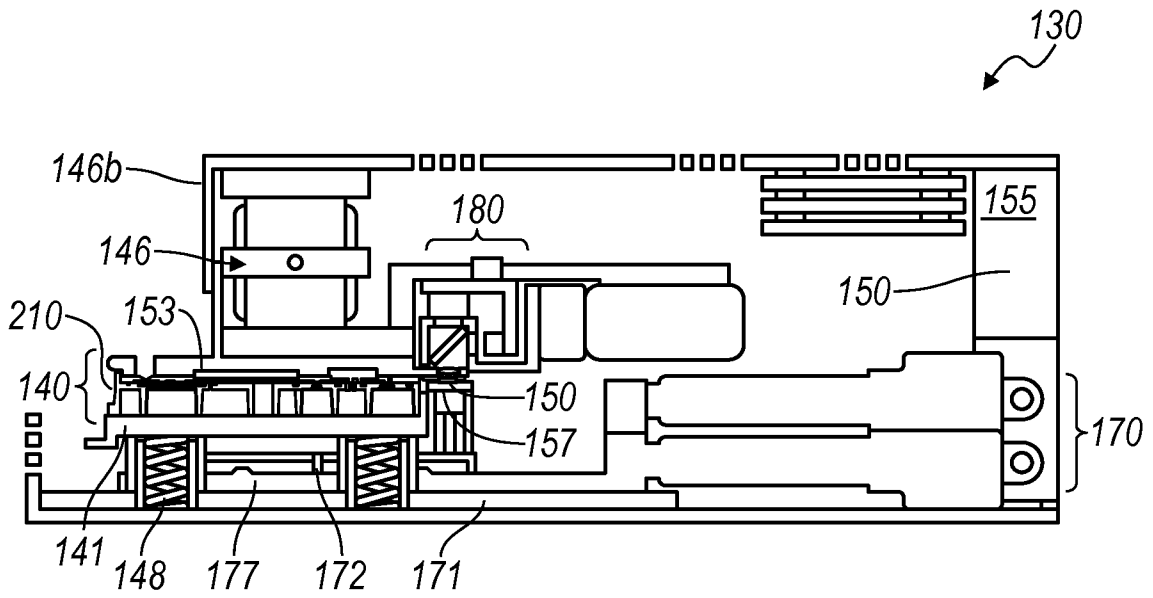

FIG. 7D

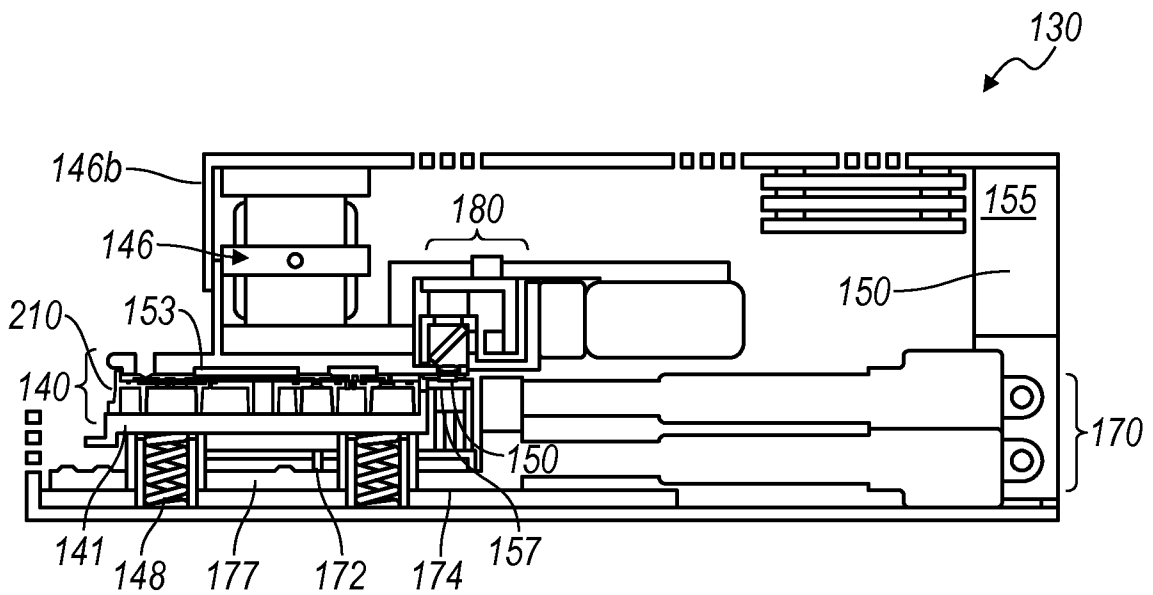

FIG. 7E

8/24

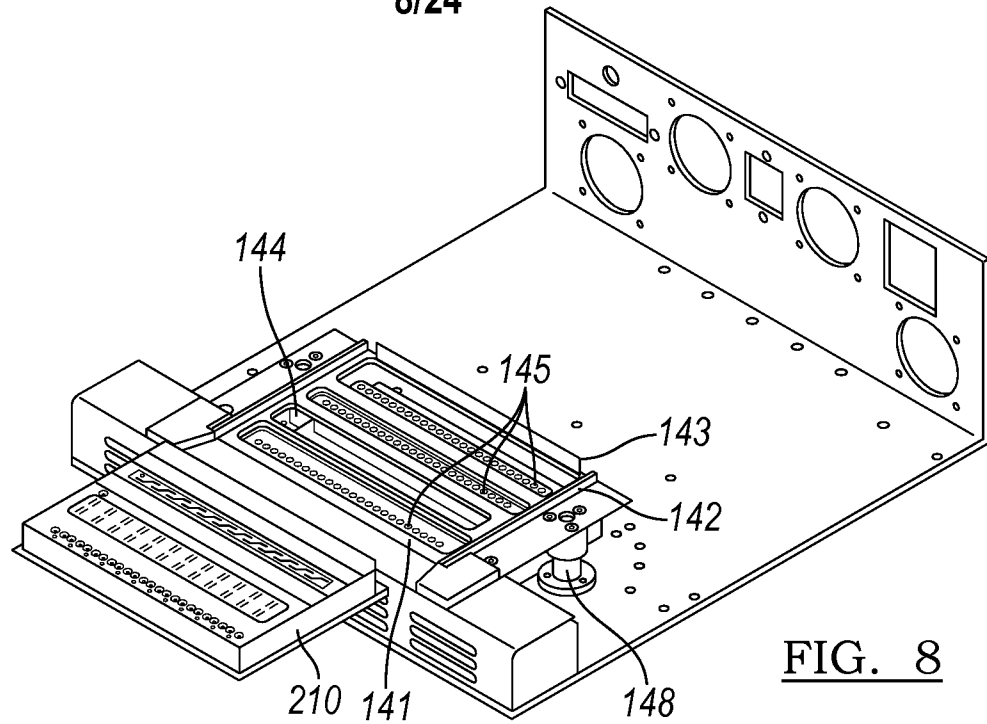

FIG. 8

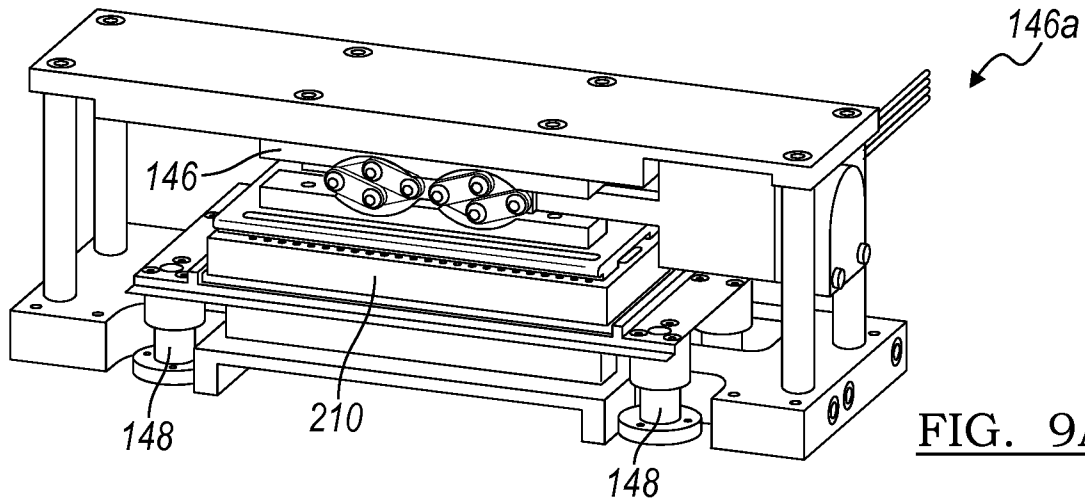

FIG. 9A

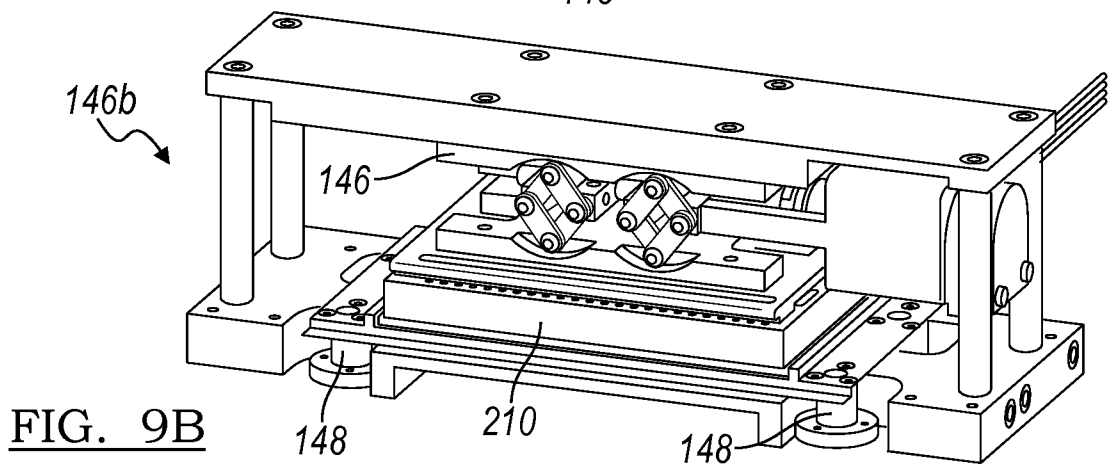
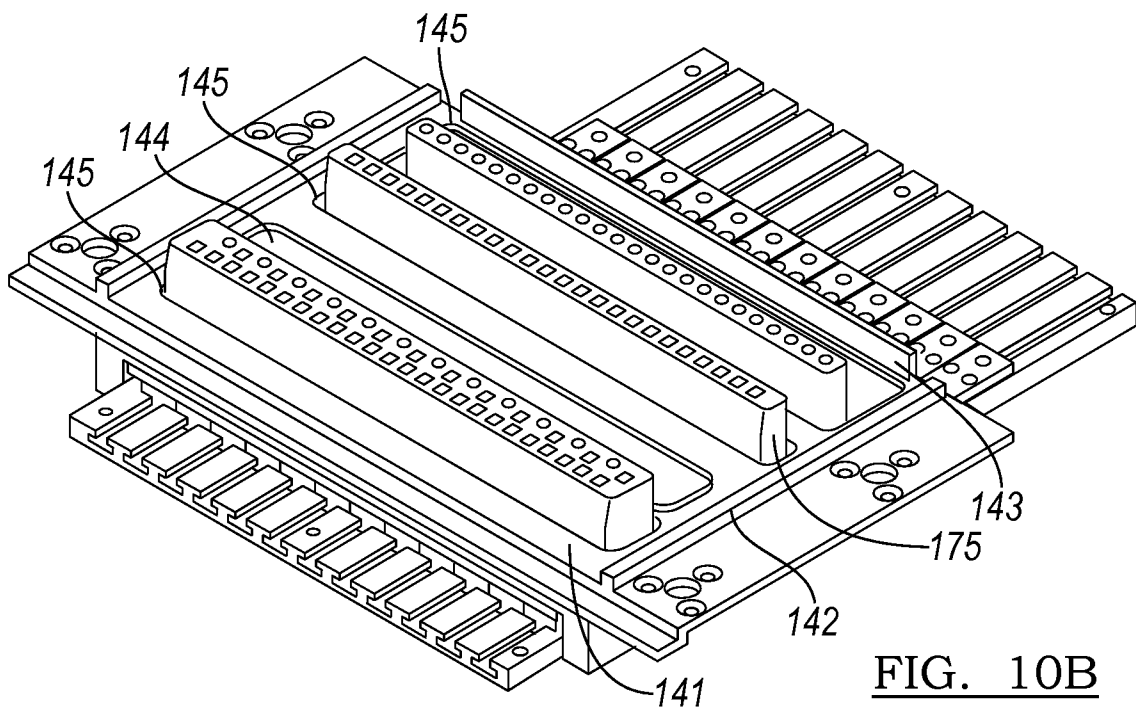
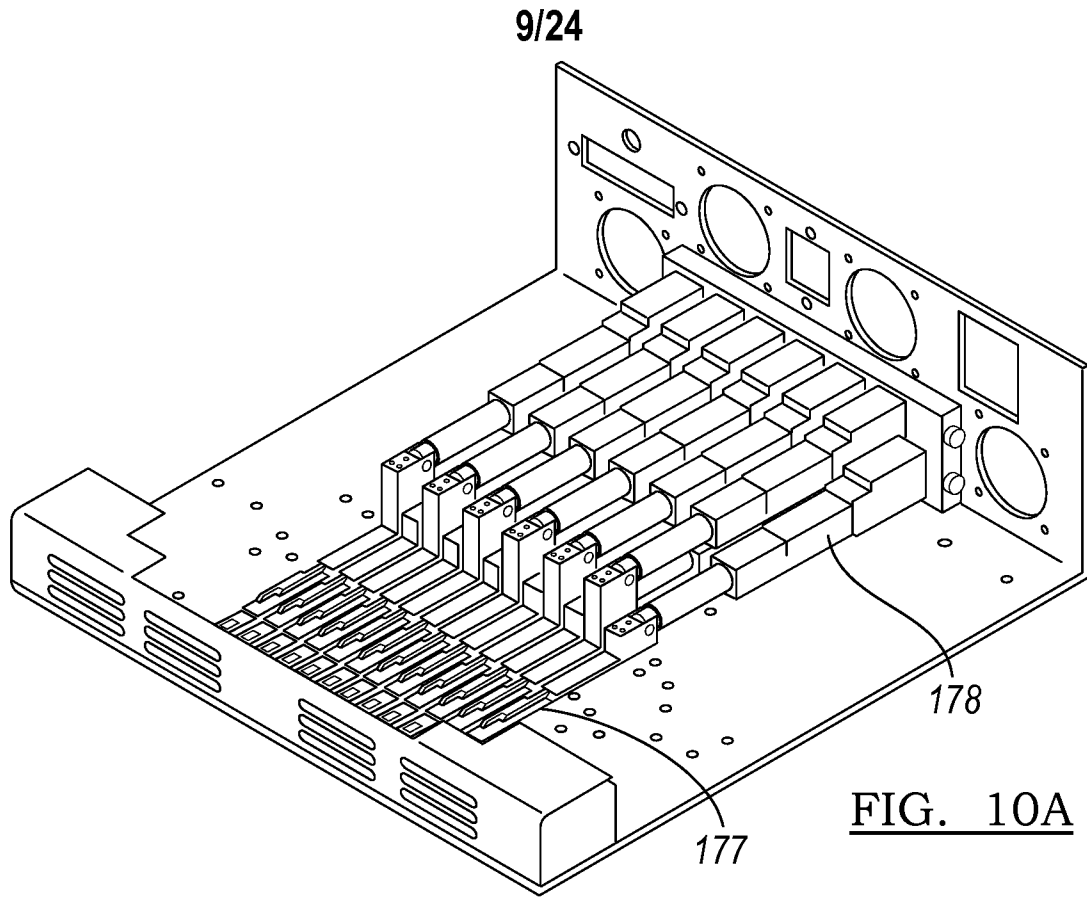

FIG. 9B



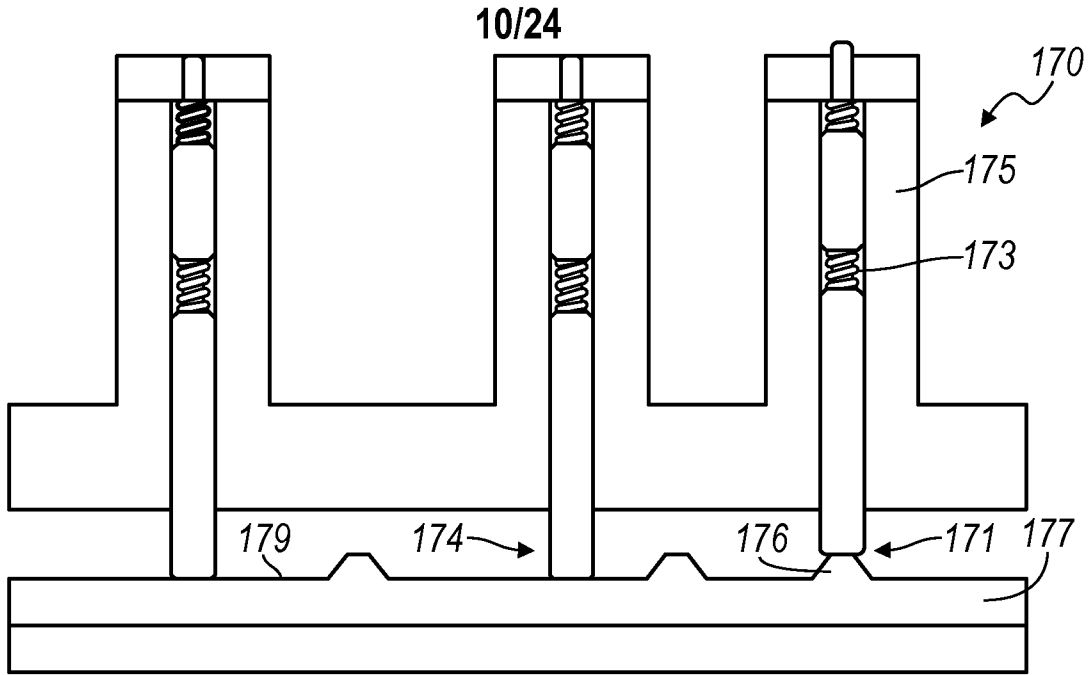

FIG. 11A

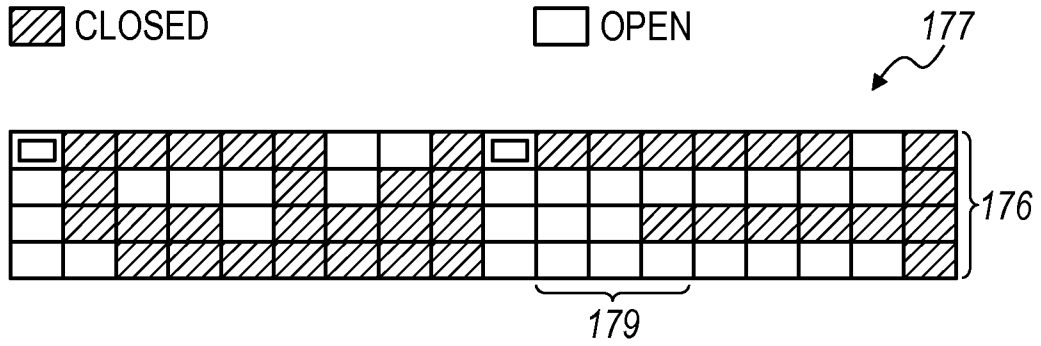

FIG. 11B

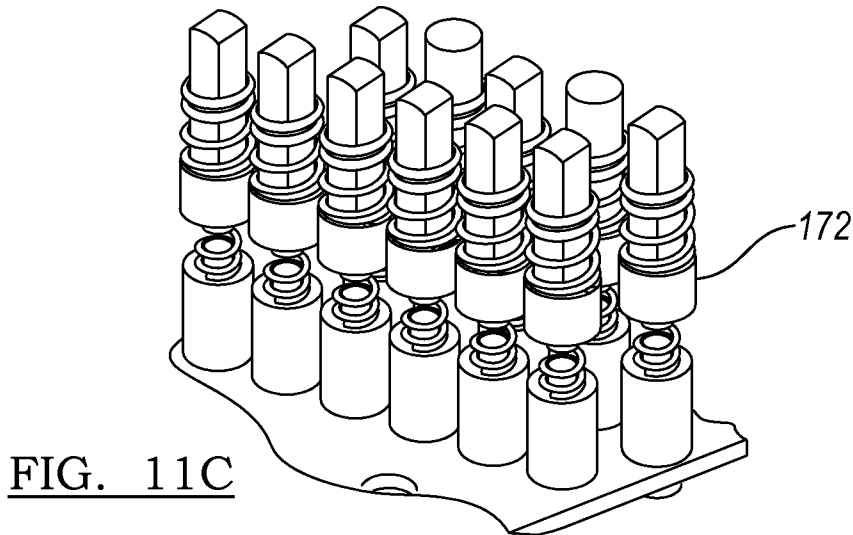

FIG. 11C

11/24

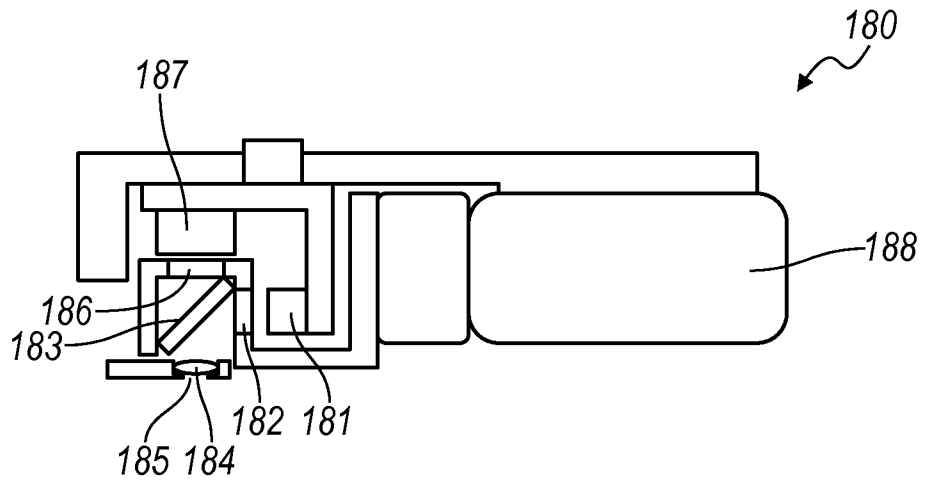

FIG. 12A

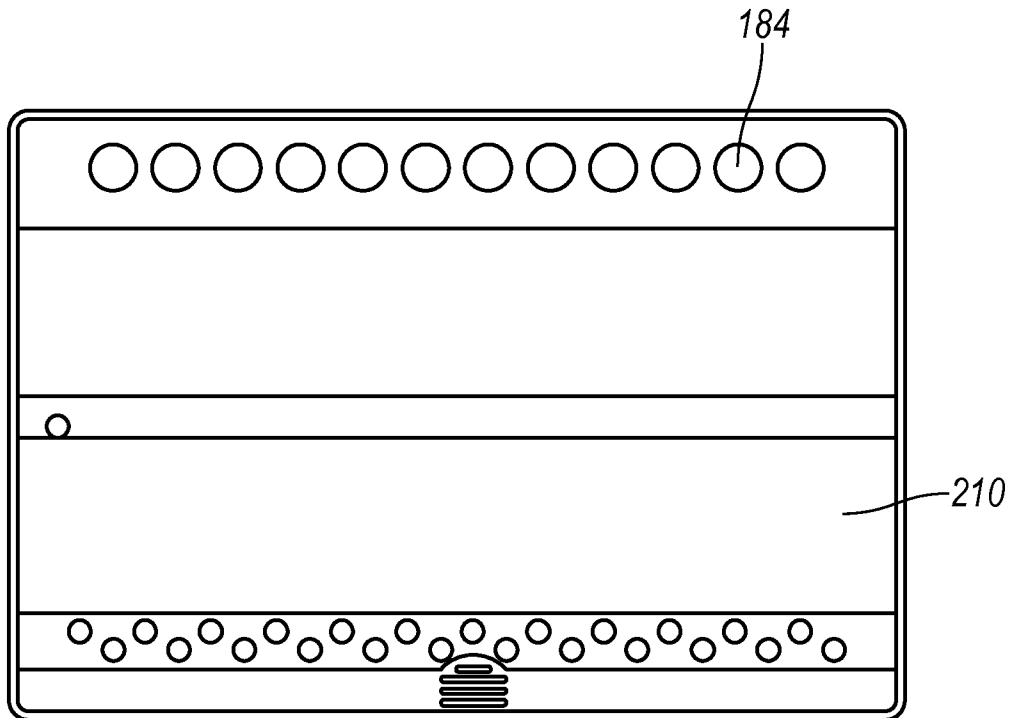

FIG. 12B

12/24

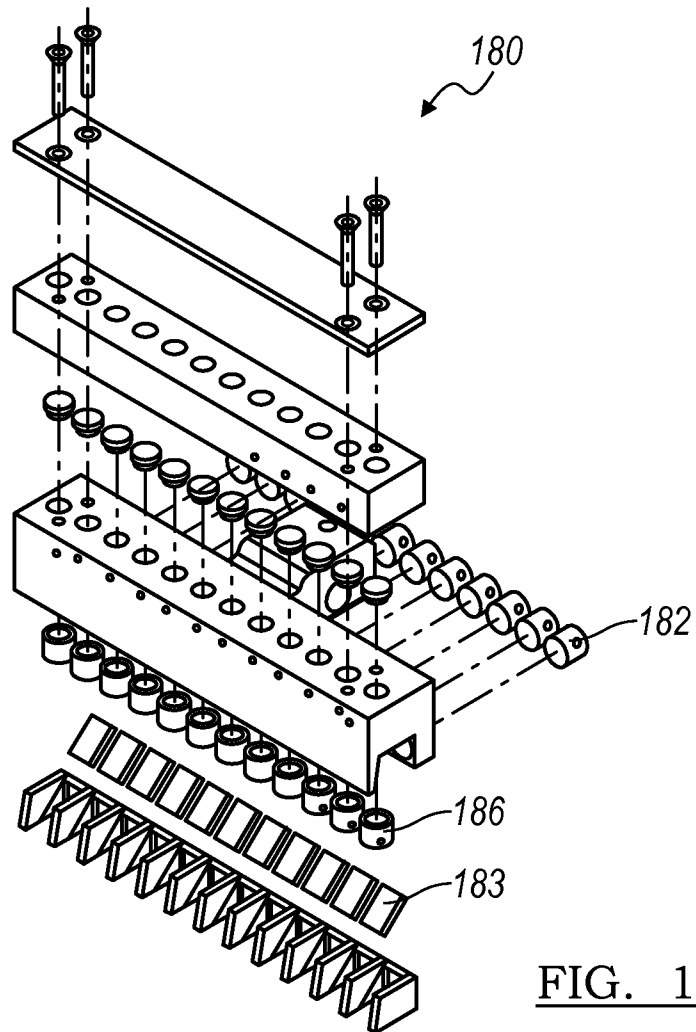

FIG. 12C

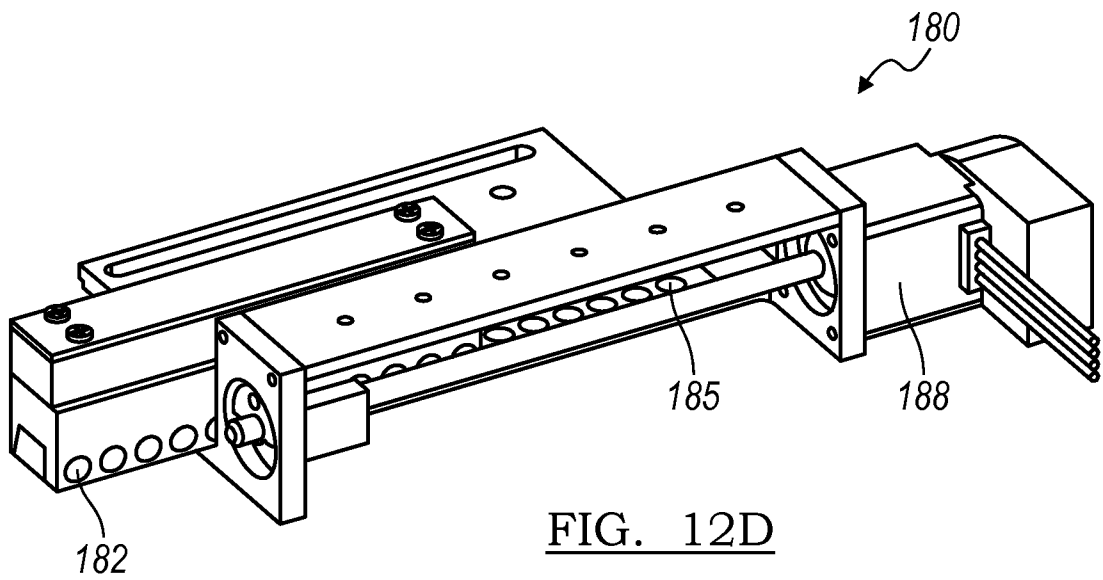

FIG. 12D

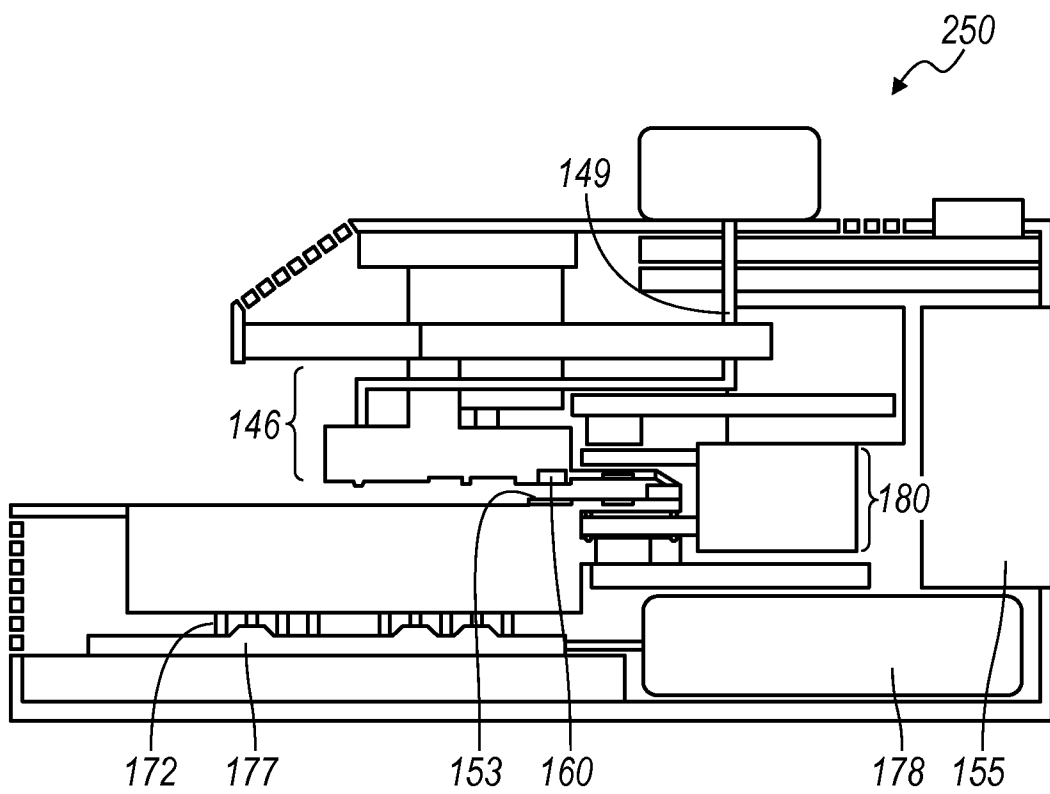

FIG. 13

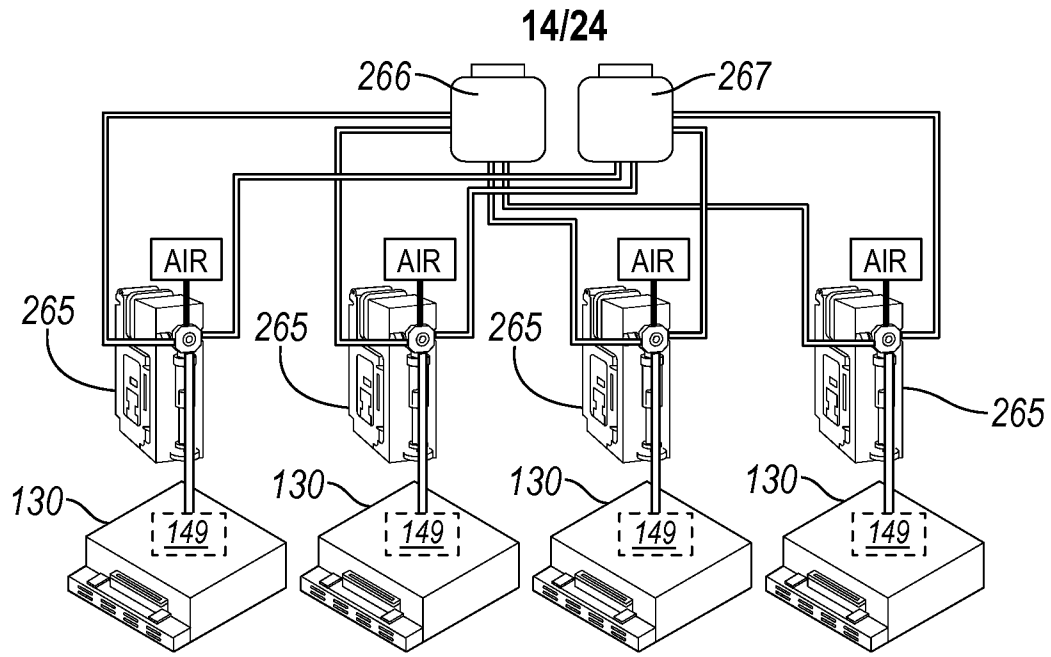

FIG. 14A

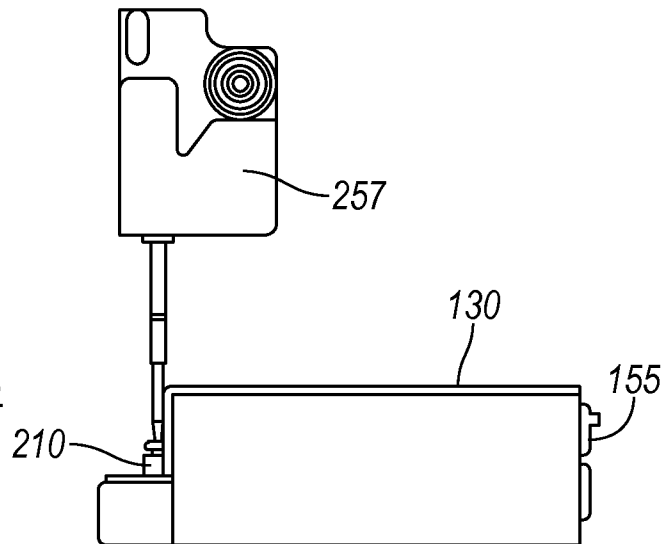

FIG. 14B

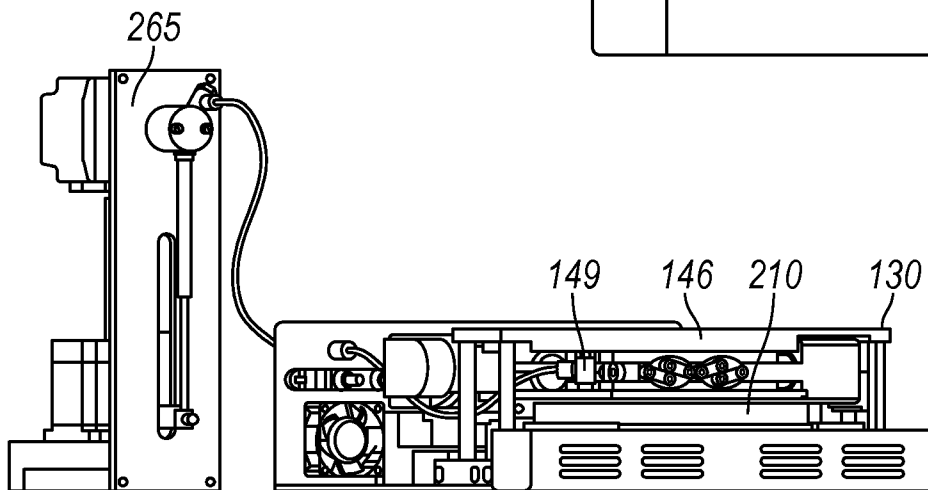

FIG. 14C

15/24

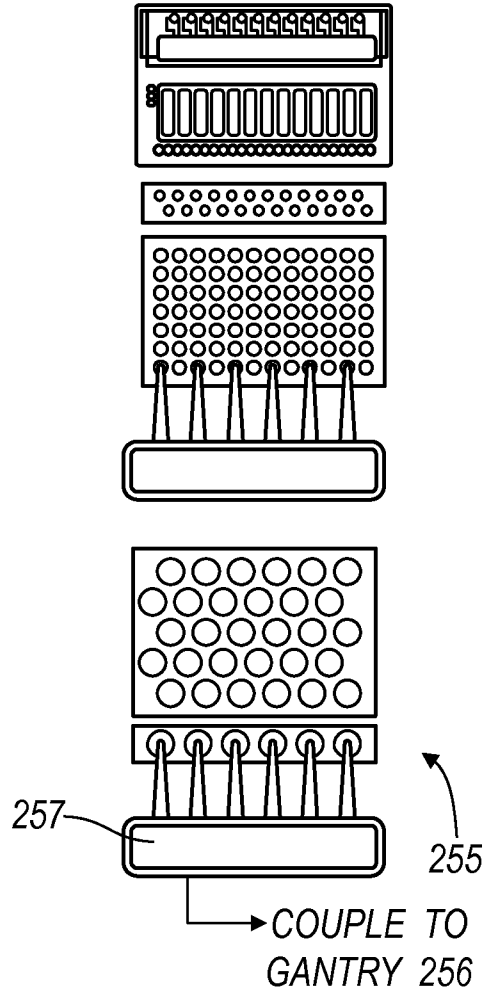
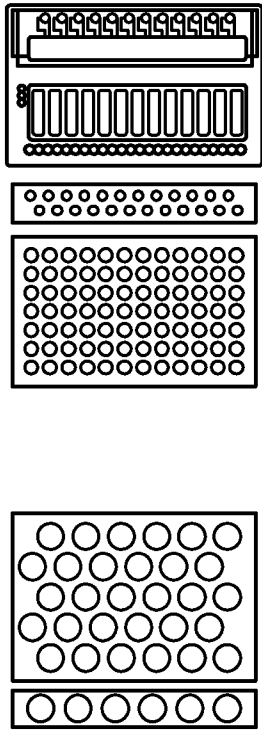

FIG. 15

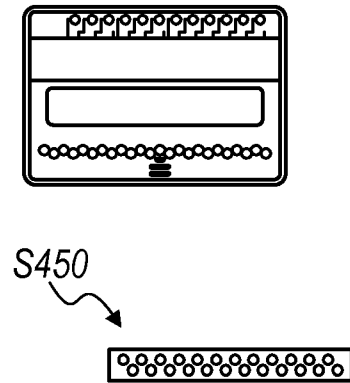
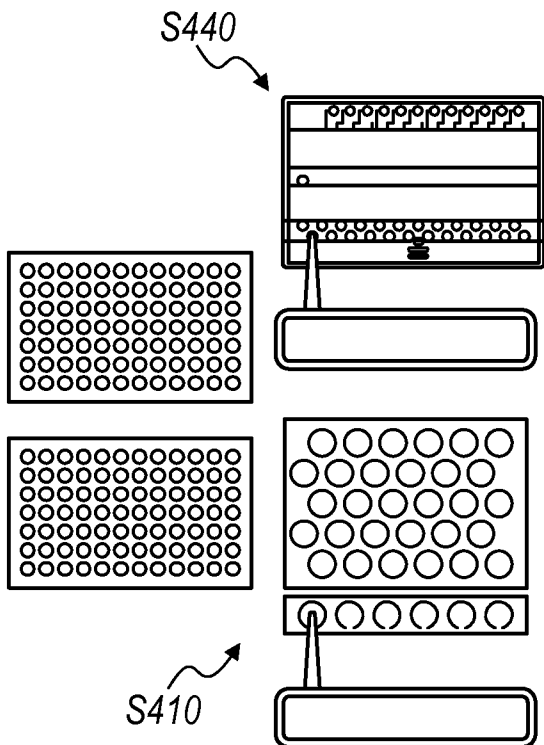

FIG. 16A

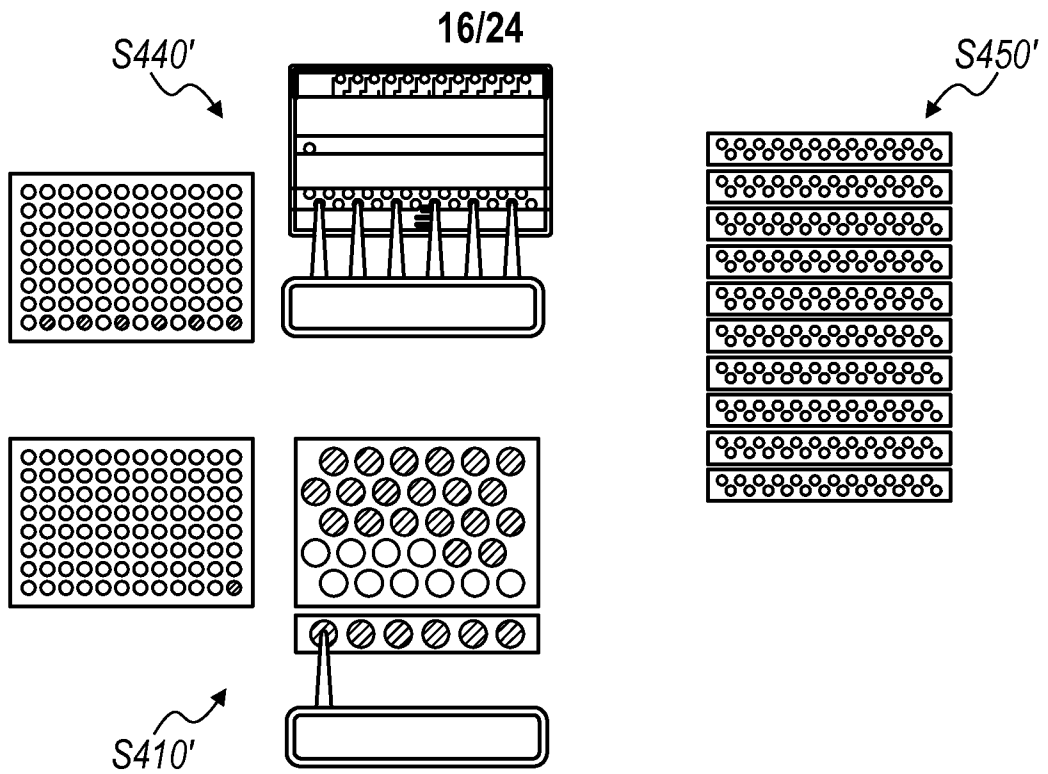

FIG. 16B

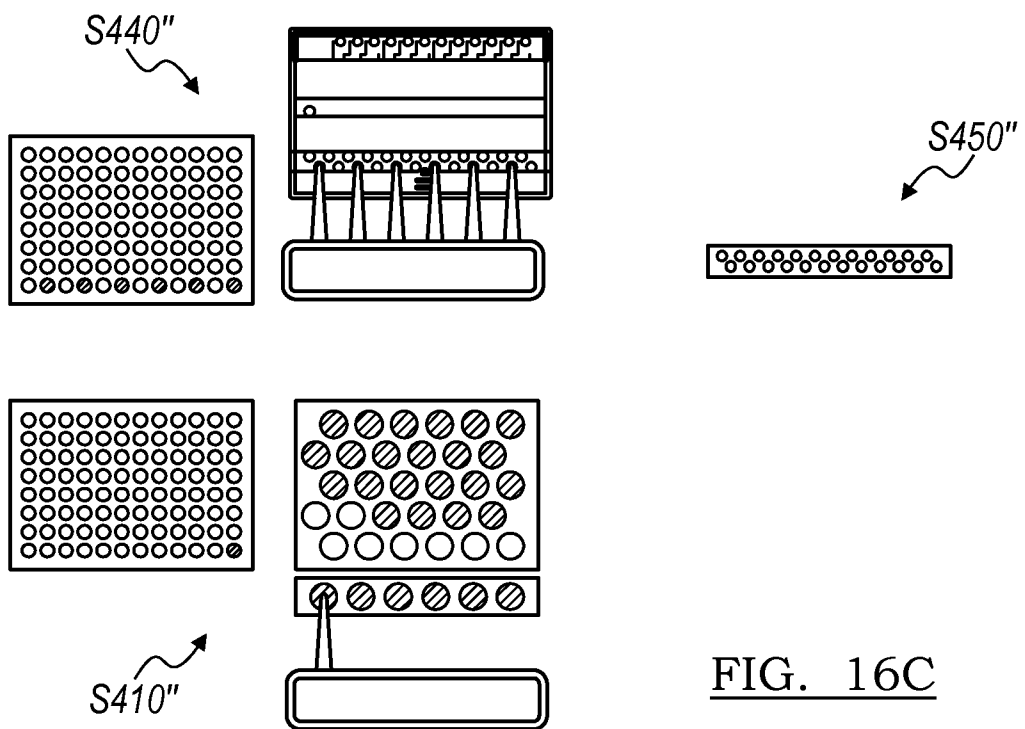

FIG. 16C

17/24

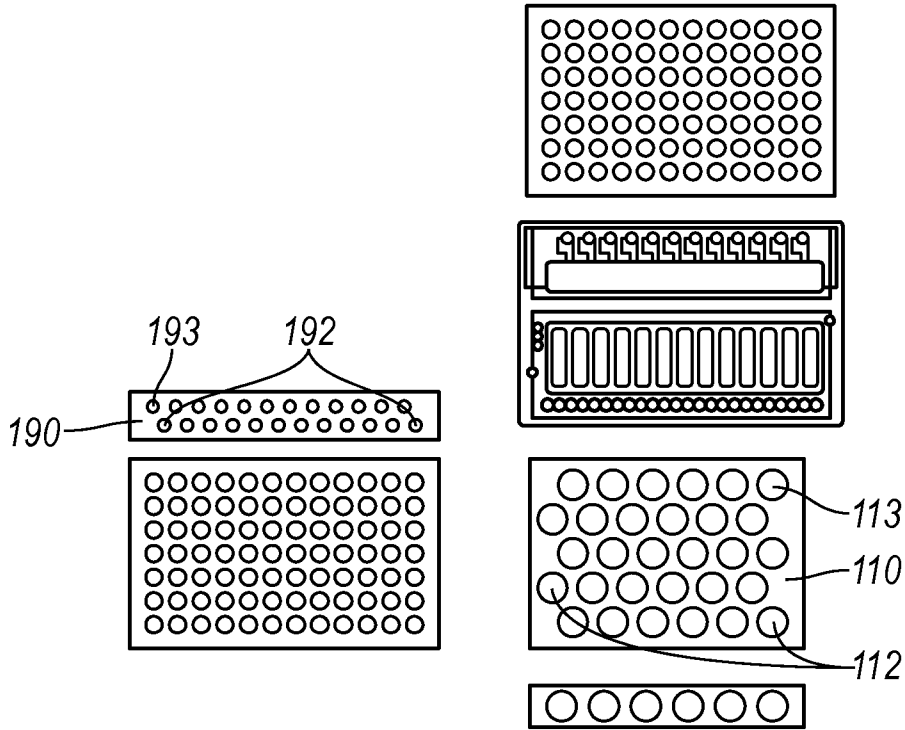

FIG. 17A

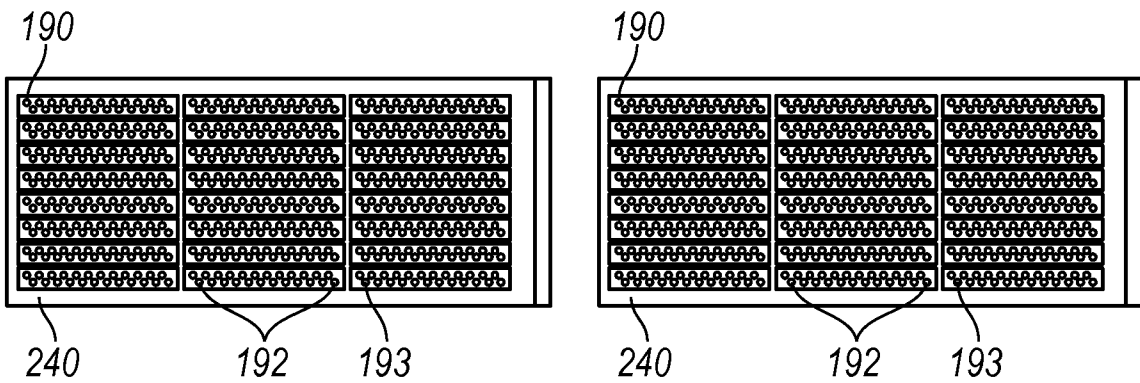

FIG. 17B

18/24

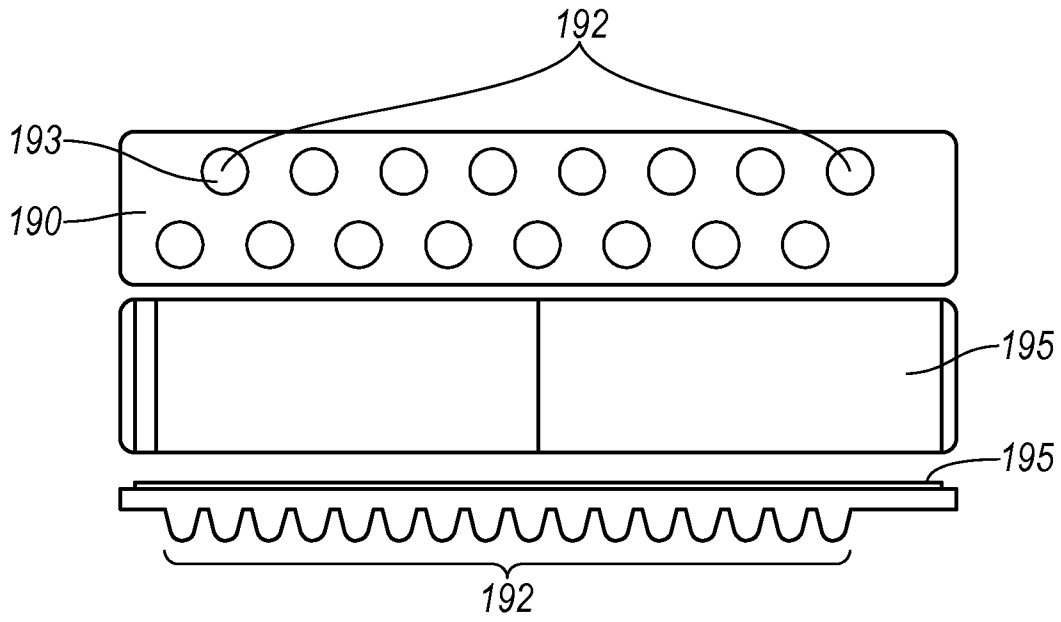

FIG. 18A

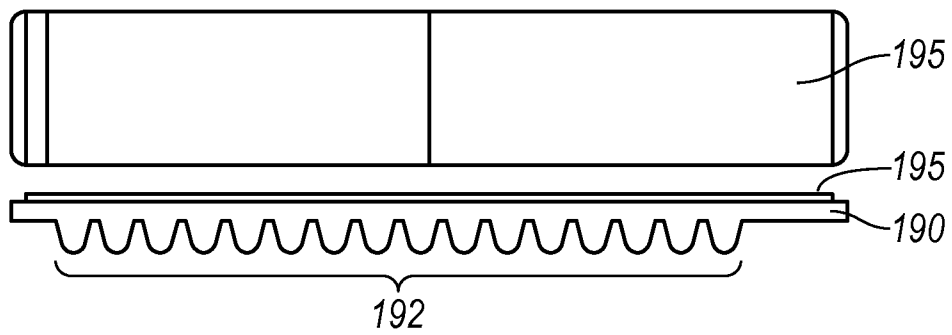

FIG. 18B

19/24

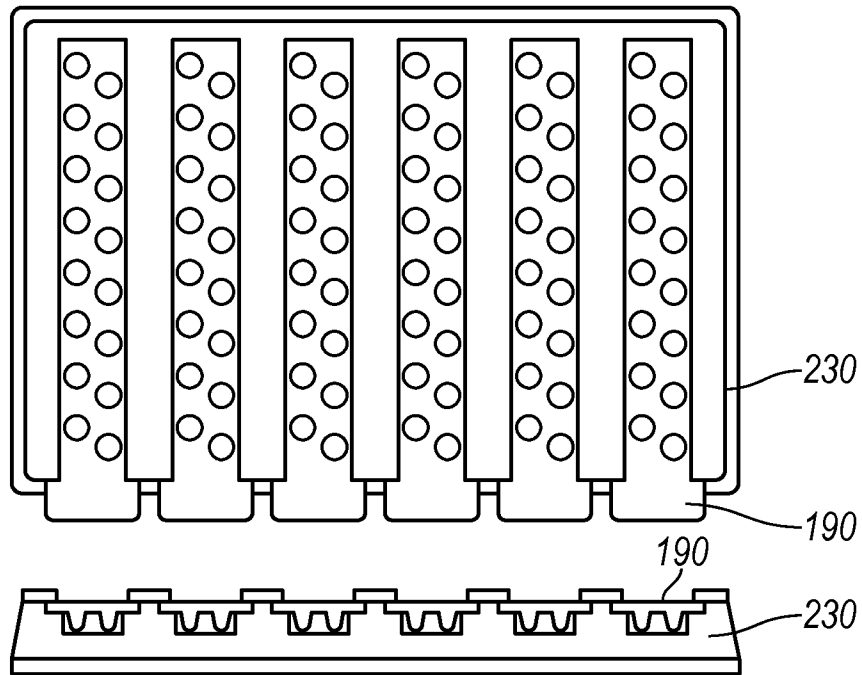

FIG. 19

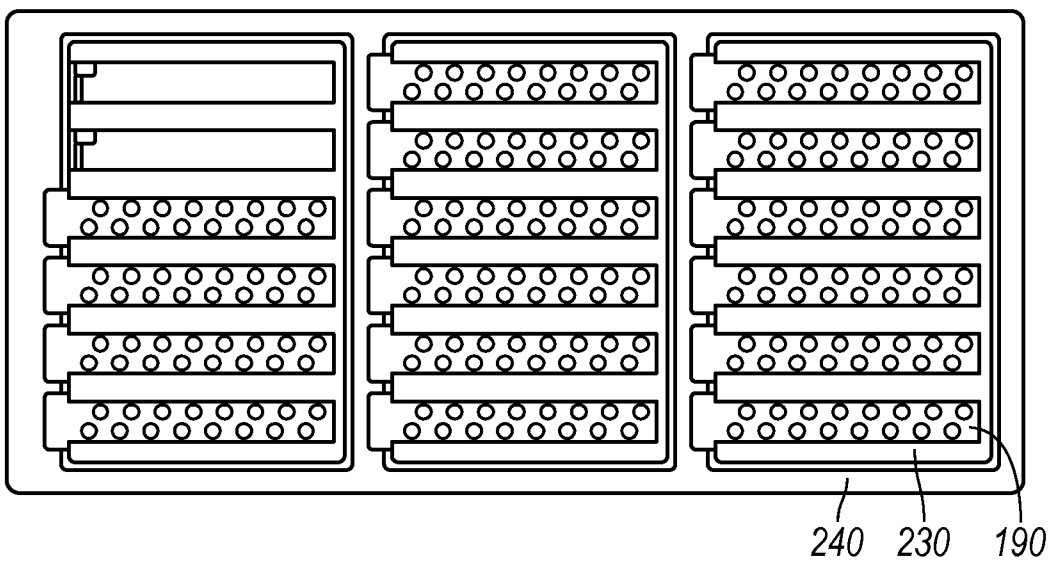

FIG. 20

20/24

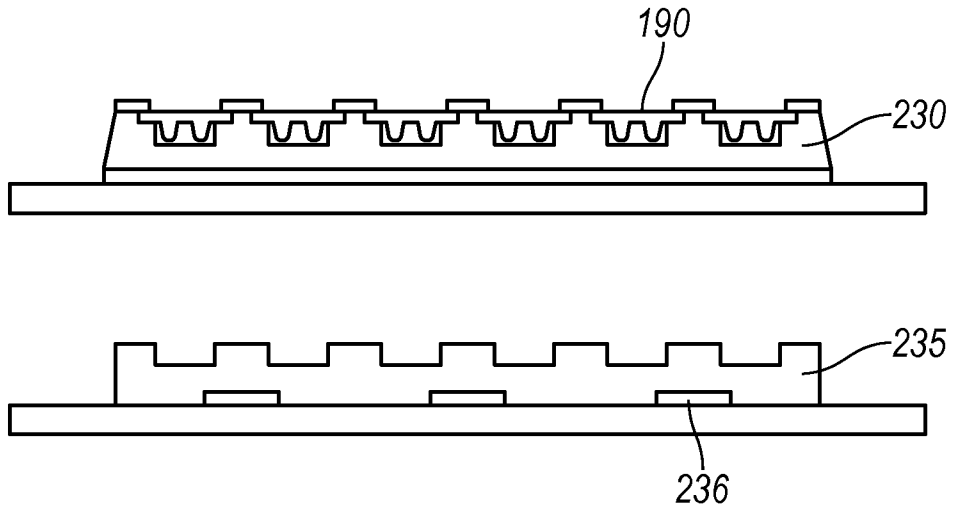

FIG. 21A

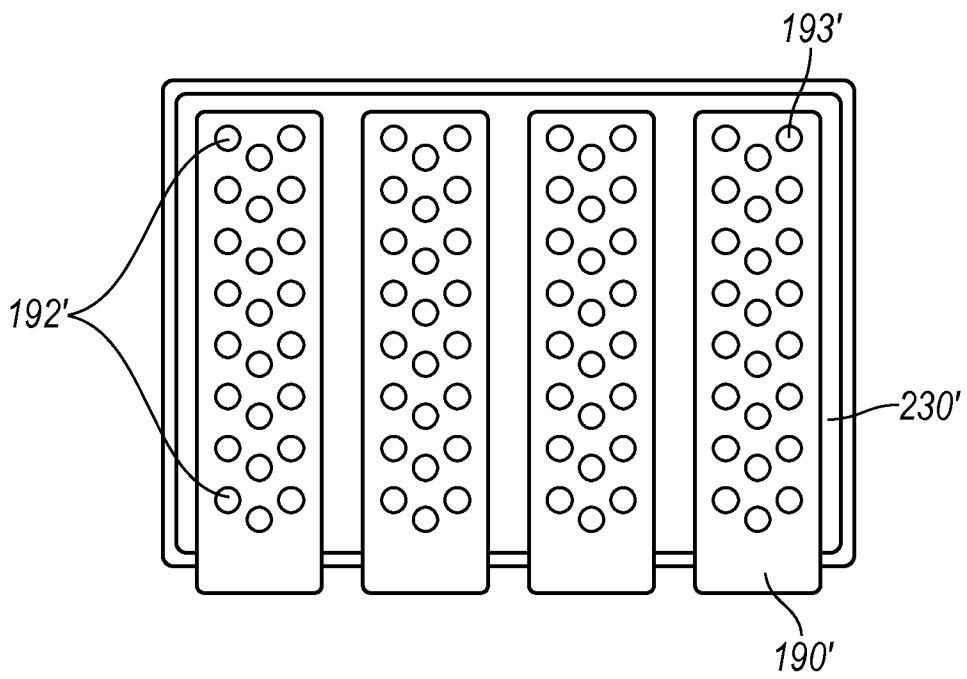

FIG. 21B

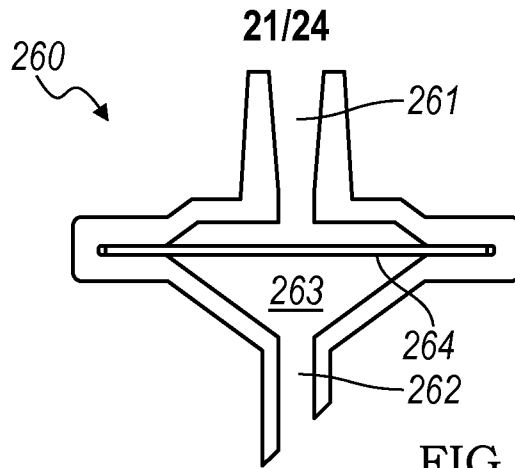

FIG. 22

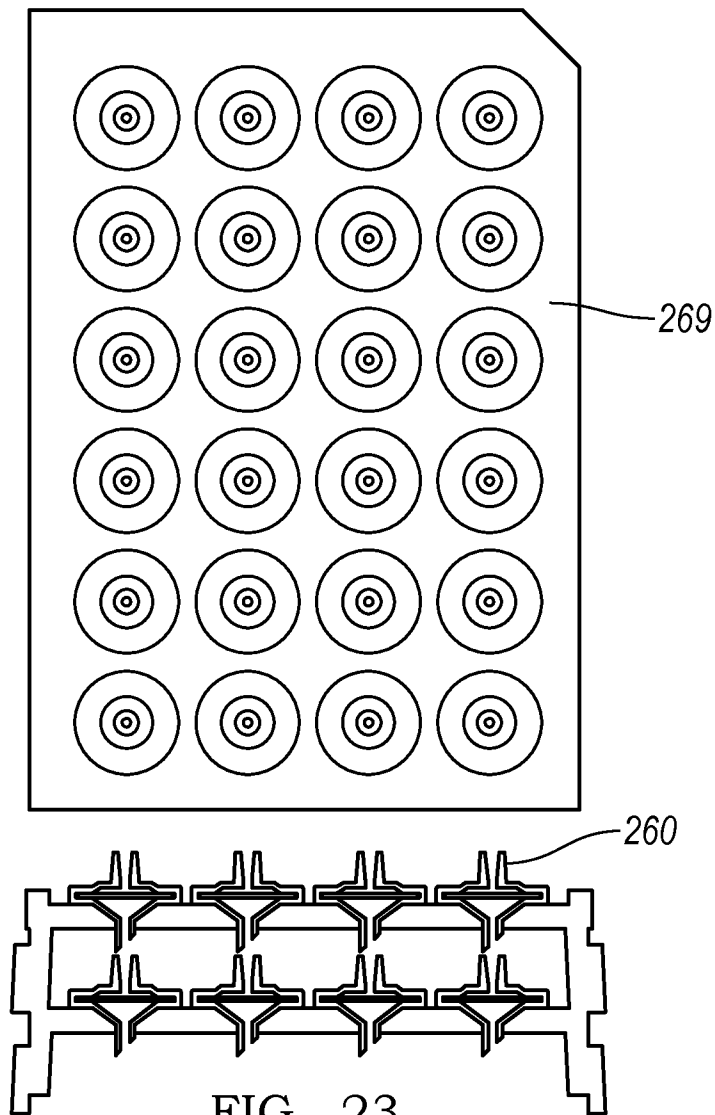

FIG. 23

22/24

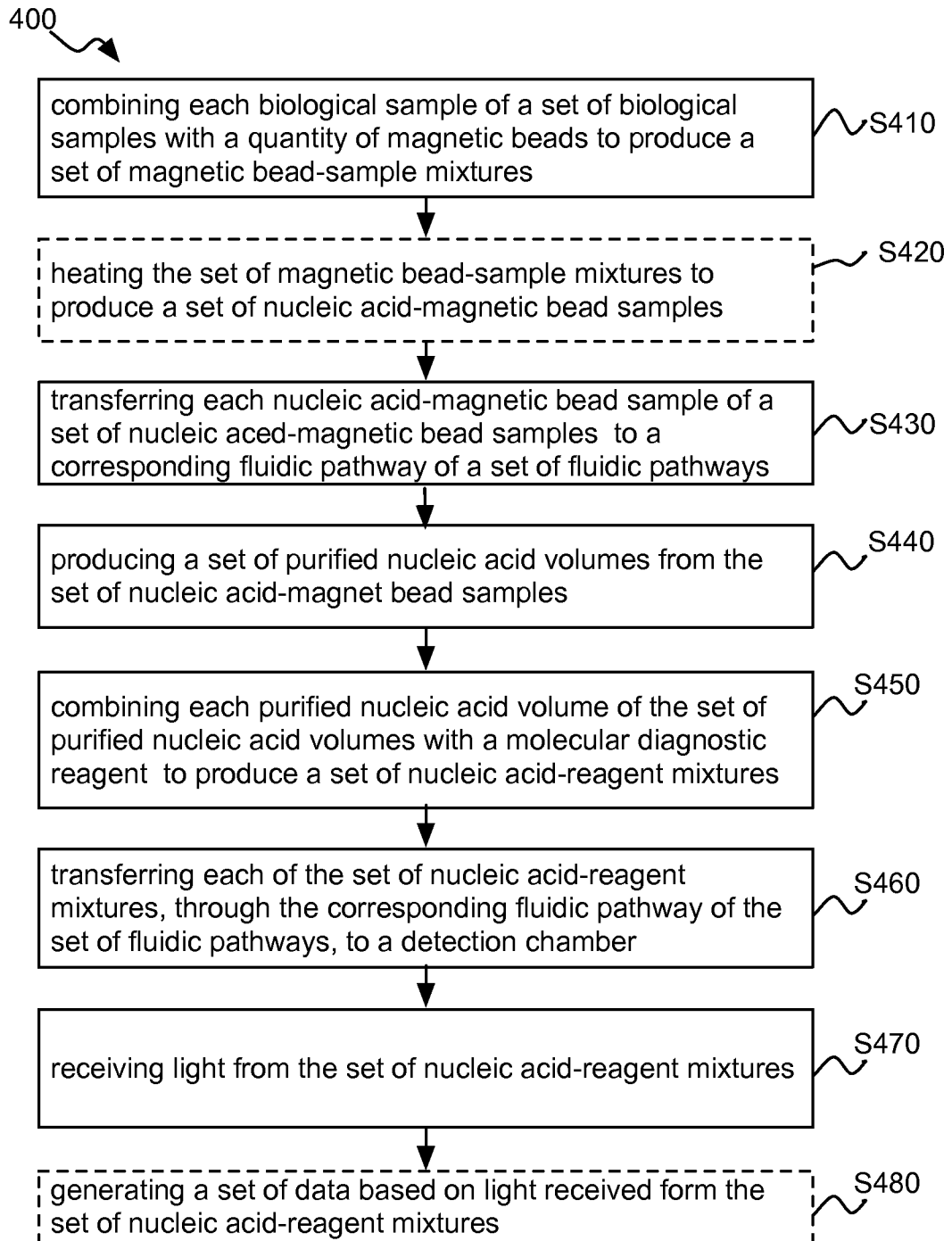

FIG. 24A

23/24

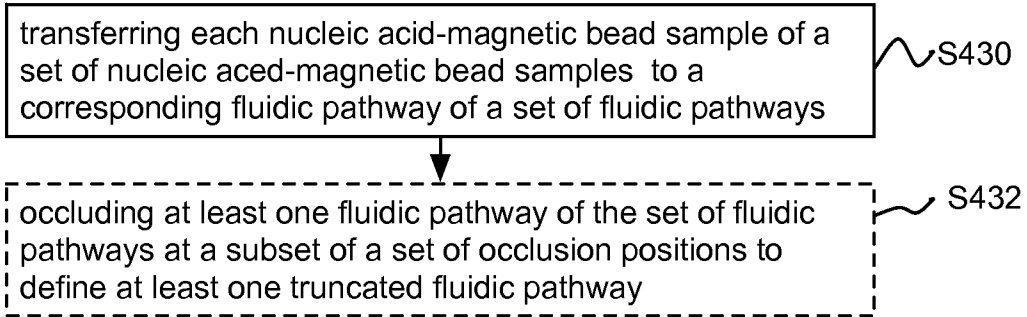

FIG. 24B

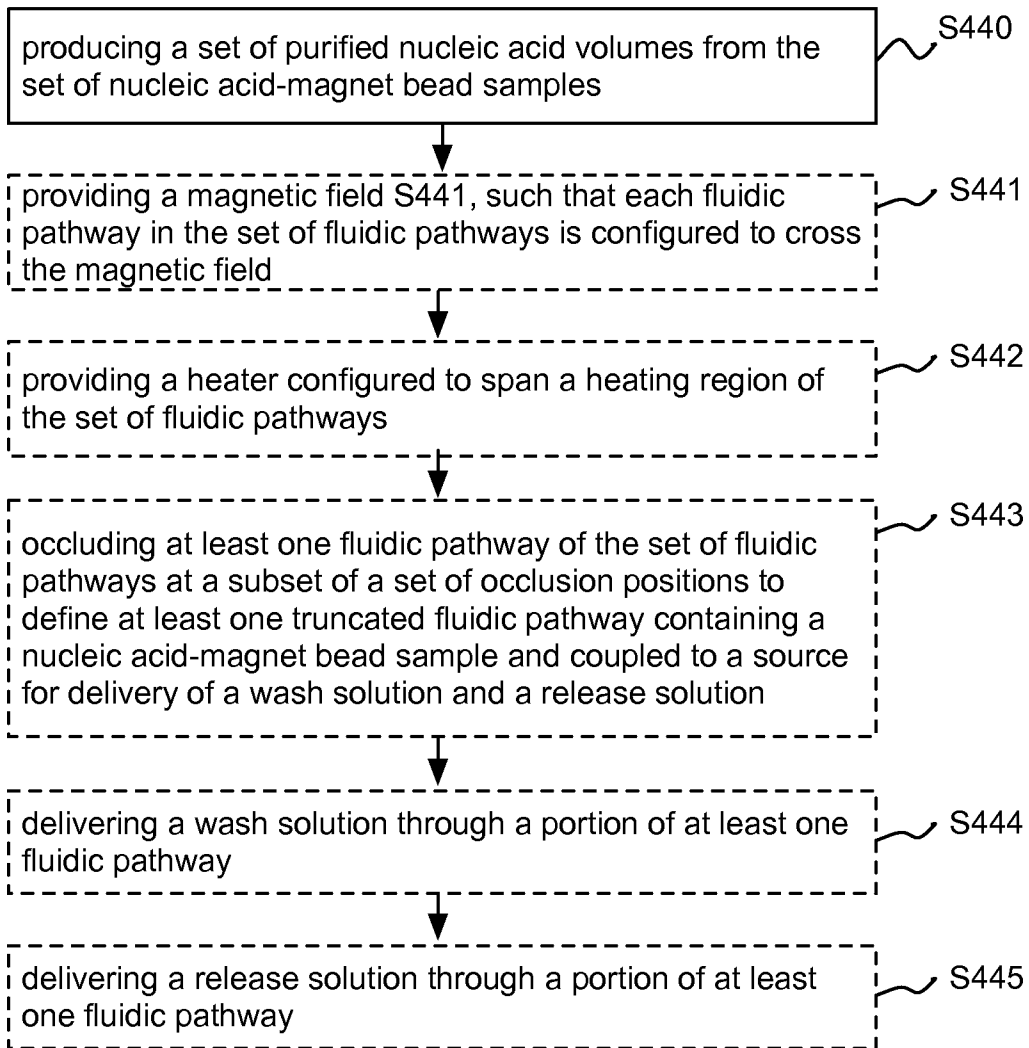
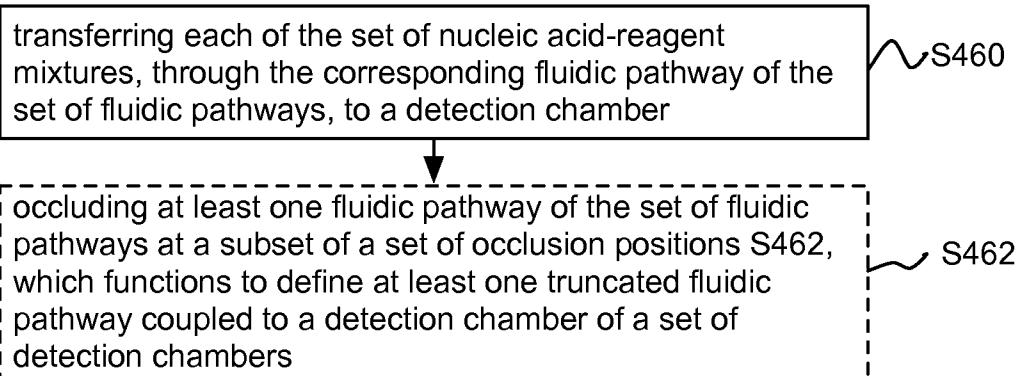

FIG. 24C

24/24

FIG. 24D

INTERNATIONAL SEARCH REPORT

International application No.
PCT/US2013/025918

A. CLASSIFICATION OF SUBJECT MATTER
 IPC(8) - C12Q 1/68 (2013.01)
 USPC - 435/288.7
 According to International Patent Classification (IPC) or to both national classification and IPC

B. FIELDS SEARCHED

Minimum documentation searched (classification system followed by classification symbols)
 IPC(8) - C12M 1/34; C12Q 1/00, 1/68(2013.01)
 USPC - 435/6.1, 6.11, 6.12, 91.1, 91.2, 287.1, 288.7

Documentation searched other than minimum documentation to the extent that such documents are included in the fields searched
 CPC - C12Q 1/68, 1/6806, 1/6844, 1/686 (2013.01)

Electronic data base consulted during the international search (name of data base and, where practicable, search terms used)
 Patbase, Google Patent

C. DOCUMENTS CONSIDERED TO BE RELEVANT

Category*	Citation of document, with indication, where appropriate, of the relevant passages	Relevant to claim No.
X	US 2010/0323919 A1 (CHEN et al) 23 December 2010 (23.12.2010) entire document	49, 50, 52-54, 57-59, 63
Y		51
Y	US 2007/0292941 A1 (HANDIQUE et al) 20 December 2007 (20.12.2007) entire document	51
A	US 2005/0233370 A1 (AMMANN et al) 20 October 2005 (20.10.2005) entire document	1-69
A	US 2010/0075311 A1 (BARRAULT et al) 25 March 2010 (25.03.2010) entire document	1-69

Further documents are listed in the continuation of Box C.

- | | |
|---|--|
| * Special categories of cited documents: | "T" later document published after the international filing date or priority date and not in conflict with the application but cited to understand the principle or theory underlying the invention |
| "A" document defining the general state of the art which is not considered to be of particular relevance | "X" document of particular relevance; the claimed invention cannot be considered novel or cannot be considered to involve an inventive step when the document is taken alone |
| "E" earlier application or patent but published on or after the international filing date | "Y" document of particular relevance; the claimed invention cannot be considered to involve an inventive step when the document is combined with one or more other such documents, such combination being obvious to a person skilled in the art |
| "L" document which may throw doubts on priority claim(s) or which is cited to establish the publication date of another citation or other special reason (as specified) | "&" document member of the same patent family |
| "O" document referring to an oral disclosure, use, exhibition or other means | |
| "P" document published prior to the international filing date but later than the priority date claimed | |

Date of the actual completion of the international search 29 March 2013	Date of mailing of the international search report 19 APR 2013
Name and mailing address of the ISA/US Mail Stop PCT, Attn: ISA/US, Commissioner for Patents P.O. Box 1450, Alexandria, Virginia 22313-1450 Facsimile No. 571-273-3201	Authorized officer: Blaine R. Copenheaver PCT Helpdesk: 571-272-4300 PCT OSP: 571-272-7774