

(19) World Intellectual Property
Organization
International Bureau



(43) International Publication Date
3 November 2005 (03.11.2005)

PCT

(10) International Publication Number
WO 2005/102415 A1

(51) International Patent Classification⁷: **A61M 3/02**,
27/00, 35/00

(21) International Application Number:
PCT/GB2005/001603

(22) International Filing Date: 27 April 2005 (27.04.2005)

(25) Filing Language: English

(26) Publication Language: English

(30) Priority Data:
0409446.2 27 April 2004 (27.04.2004) US

(71) Applicant (for all designated States except US): **SMITH & NEPHEW, PLC** [GB/GB]; 15 Adam Street, London WC2N 6LA (GB).

(72) Inventors; and

(75) Inventors/Applicants (for US only): **BLOTT, Patrick, Lewis** [GB/GB]; 16 Hodsow Fields, Barmby Moor, York

YO24 4ER (GB). **HARTWELL, Edward**, Yerbury [GB/GB]; 3 Haven Garth, Brough, Hull HU15 1EP (GB). **LEE-WEBB, Julian** [GB/GB]; 37 Moor Lane, Copmanthorpe, York YO23 3TJ (GB). **NICOLINI, Derek** [GB/GB]; 38 Castle Rise, South Cave, Brough HU15 2ET (GB).

(74) Agent: **DRAGGETT, Peter, Thornton**; Smith & Nephew, York Science Park, Heslington, York YO10 5DF (GB).

(81) Designated States (unless otherwise indicated, for every kind of national protection available): AE, AG, AL, AM, AT, AU, AZ, BA, BB, BG, BR, BW, BY, BZ, CA, CH, CN, CO, CR, CU, CZ, DE, DK, DM, DZ, EC, EE, EG, ES, FI, GB, GD, GE, GH, GM, HR, HU, ID, IL, IN, IS, JP, KE, KG, KM, KP, KR, KZ, LC, LK, LR, LS, LT, LU, LV, MA, MD, MG, MK, MN, MW, MX, MZ, NA, NI, NO, NZ, OM, PG, PH, PL, PT, RO, RU, SC, SD, SE, SG, SK, SL, SM, SY, TJ, TM, TN, TR, TT, TZ, UA, UG, US, UZ, VC, VN, YU, ZA, ZM, ZW.

[Continued on next page]

(54) Title: DRESSING AND APPARATUS FOR CLEANSING THE WOUNDS

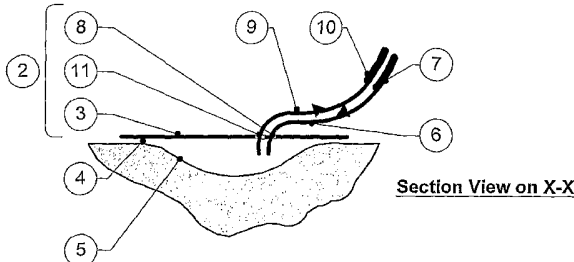
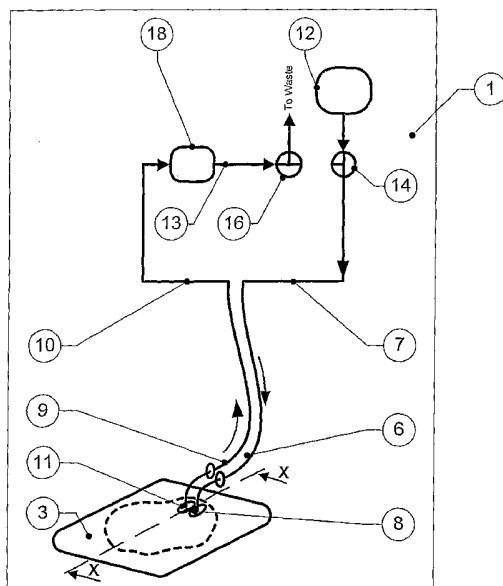

(57) Abstract: A dressing (2) and an apparatus (1) comprising the dressing, for cleansing the wounds (5) in which an irrigant fluid from a reservoir (12) connected to a conformable would dressing and would exudate from the dressing are moved by a device (18) (which may be a single pump or two pumps) for moving fluid through a flow Path (6, 7, 9, 10) which passes through the dressing with a means for providing simultaneous aspiration and irrigation of the wound, to provide a desired balance of fluid at a controlled nominal flow rate that removes materials deleterious to wound healing, while distributing materials that are beneficial in promoting would healing over the would bed.

WO 2005/102415 A1



(84) Designated States (unless otherwise indicated, for every kind of regional protection available): ARIPO (BW, GH, GM, KE, LS, MW, MZ, NA, SD, SL, SZ, TZ, UG, ZM, ZW), Eurasian (AM, AZ, BY, KG, KZ, MD, RU, TJ, TM), European (AT, BE, BG, CH, CY, CZ, DE, DK, EE, ES, FI, FR, GB, GR, HU, IE, IS, IT, LT, LU, MC, NL, PL, PT, RO, SE, SI, SK, TR), OAPI (BF, BJ, CF, CG, CI, CM, GA, GN, GQ, GW, ML, MR, NE, SN, TD, TG).

For two-letter codes and other abbreviations, refer to the "Guidance Notes on Codes and Abbreviations" appearing at the beginning of each regular issue of the PCT Gazette.

Published:

— with international search report

DRESSING AND APPARATUS FOR CLEANSING THE WOUNDS

The present invention relates to apparatus and a medical wound dressing for aspirating, irrigating and/or cleansing wounds, and a method of treating
5 wounds using such apparatus for aspirating, irrigating and/or cleansing wounds.

It relates in particular to such an apparatus, wound dressing and method that can be easily applied to a wide variety of, but in particular chronic,
10 wounds, to cleanse them of materials that are deleterious to wound healing, whilst distributing materials that are beneficial in some therapeutic aspect, in particular to wound healing.

Aspirating and/or irrigating apparatus are known, and tend to be used to
15 remove wound exudate during wound therapy. In known forms of such wound therapy, aspiration and irrigation of the wound take place sequentially.

Each part of the therapy cycle is beneficial in promoting wound healing:
20

Aspiration applies a negative pressure to the wound, which is beneficial in itself in promoting wound healing by removing materials deleterious to wound healing with the wound exudate, reducing bacterial load, combating peri-wound oedema, increasing local blood flow to the wound and
25 encouraging the formation of wound bed granulation tissue.

Irrigation cleanses wounds of materials that are deleterious to wound healing by diluting and moving wound exudate (which is typically relatively little fluid and may be of relatively high viscosity and particulate-filled).
30

Additionally, relatively little of beneficial materials involved in promoting wound healing (such as cytokines, enzymes, growth factors, cell matrix components, biological signalling molecules and other physiologically active components of the exudate) are present in a wound, and are not well
35 distributed in the wound, i.e. they are not necessarily present in parts of the wound bed where they can be potentially of most benefit. These may be distributed by irrigation of the wound and thus aid in promoting wound healing.

The irrigant may additionally contain materials that are potentially or actually beneficial in respect of wound healing, such as nutrients for wound cells to aid proliferation, and gases, such as oxygen. These may be distributed by irrigation of the wound and thus aid in promoting wound healing.

If aspiration and irrigation therapy is applied sequentially to a wound, the two therapies, each of which is beneficial in promoting wound healing, can only be applied intermittently.

Thus, the wound will lose the abovementioned known beneficial effects of aspiration therapy on wound healing, at least in part, while that aspiration is suspended during irrigation.

Additionally, for a given aspirate flow, whilst materials that are potentially or actually deleterious in respect of wound healing are removed from wound exudate, the removal in a given time period of application of the total irrigate and/or aspirate therapy will normally be less effective and/or slower than with continuous application of aspiration.

Even less to be desired, is that while aspiration is not applied to the wound, wound exudate and materials deleterious to wound healing (such as bacteria and debris, and iron II and iron III and for chronic wounds proteases, such as serine proteases) will pool on the wound bed and hinder wound healing, especially in a highly exuding wound. The influx of local oedema will also add to the chronicity of the wound. This is especially the case in chronic wounds.

Depending on the relative volumes of irrigant and wound exudate, the mixed exudate-irrigant fluid and may be of relatively high viscosity and/or particulate-filled. Once it is present and has pooled, it may be more difficult to shift by the application of aspiration in a conventional sequential aspirate – irrigate – dwell cycle than with continuous simultaneous aspiration of the wound, owing to the viscosity and blockage in the system.

35

The wound will also lose the abovementioned beneficial effects of irrigation therapy on wound healing, at least in part, while that irrigation is suspended during aspiration.

- 5 These benefits in promoting wound healing include the movement of materials that are beneficial in promoting wound healing, such as those mentioned above.

10 Additionally, for a given irrigant flow, the cleansing of the wound and the distribution by irrigation of the wound of such beneficial materials in a given time period of application of the total irrigate and/or aspirate therapy when such therapy is in a conventional sequential aspirate – irrigate – dwell cycle will normally be less effective and/or slower than with continuous application of aspiration.

15 Such known forms of aspiration and/or irrigation therapy systems also often create a wound environment that may result in the loss of optimum performance of the body's own tissue healing processes, and slow healing and/or in weak new tissue growth that does not have a strong three-dimensional structure adhering well to and growing from the wound bed.
20 This is a significant disadvantage, in particular in chronic wounds.

The relevant devices tend not to be portable.

- 25 It thus would be desirable to provide a system of aspiration and irrigation therapy for a wound, which can remove wound exudate and materials deleterious to wound healing from contact with the wound bed, whilst simultaneously cleansing it and distributing materials that are
30 beneficial in promoting wound healing across it.

It is an object of the present invention to obviate at least some of the abovementioned disadvantages of known aspiration and/or irrigation therapy systems.

35 It is a yet further object of the present invention

- a) to obviate at least some of the abovementioned disadvantages of known aspiration and/or irrigation systems, and
- b) is portable.

5 Vascular supply to, and aspiration in, tissue underlying and surrounding the wound is often compromised.

It is a further object of the present invention to provide a system of therapy that also promotes vascular supply to tissue underlying and surrounding a
10 wound, promoting wound healing.

Thus, according to a first aspect of the present invention there is provided an apparatus for aspirating, irrigating and/or cleansing wounds, comprising

- 15 a) a fluid flow path, comprising a conformable wound dressing, having a backing layer which is capable of forming a relatively fluid-tight seal or closure over a wound and at least one inlet pipe for connection to a fluid supply tube, which passes through and/or under the wound-facing face, and and at least one outlet pipe for connection to a fluid offtake tube, which
20 passes through and/or under the wound-facing face, the point at which the or each inlet pipe and the or each outlet pipe passes through and/or under the wound-facing face forming a relatively fluid-tight seal or closure over the wound;
- 25 b) a fluid reservoir connected by a fluid supply tube to an inlet pipe via optional means for supply flow regulation;
- c) at least one device for moving fluid through the wound dressing; characterised in that it comprises
- 30 d) means for providing simultaneous aspiration and irrigation of the wound, such that fluid may be supplied to fill the flowpath from the fluid reservoir via the fluid supply tube (optionally via means for supply flow regulation) while fluid is aspirated by a device through the fluid offtake tube (optionally or as necessary via means for aspirate flow regulation).

Where any pipe is described in connection with the apparatus as being connected or for connection to a (mating end of a) tube, e.g. a fluid supply tube or fluid offtake tube, the pipe and the tube may form a single integer in the flow path.

5

The present invention in this aspect provides several advantages.

One is that application of an irrigant to a wound under simultaneous aspiration creates a wound environment that is exposed to the continuous beneficial effects of both aspects of the therapy for wound healing, as opposed to the sequential intermittent application of irrigant flow and aspiration in known aspirating and/or irrigating apparatus. The latter result in less than optimum performance of the body's own tissue healing processes, and slower healing and/or weaker tissue growth that does not have a strong three-dimensional structure adhering well to and growing from the wound bed. This is a significant disadvantage, in particular in chronic wounds.

Thus, the use of the apparatus of this first aspect of the present invention for aspirating, irrigating and/or cleansing wounds retains and enhances the beneficial effects of aspiration in respect of wound healing by continuous and preferably constant aspiration. These include removing materials deleterious to wound healing with the wound exudate, reducing bacterial load, combating peri-wound oedema and encouraging the formation of wound bed granulation tissue.

Preferred embodiments of the apparatus of this first aspect of the present invention for aspirating, irrigating and/or cleansing chronic wounds apply a milder negative pressure than in conventional negative pressure therapy (which is too aggressive for the fragile tissues of many such wounds). This leads to increased patient comfort, and lessens the risk of inflammation of the wound.

35

The removal of wound exudate in a given time period of application of the total irrigate and/or aspirate therapy will normally be more effective and/or faster than with a conventional sequential intermittent aspiration and/or irrigation therapy.

5

Even more desirably, since simultaneous aspiration and irrigation is applied to the wound, wound exudate and materials deleterious to wound healing (such as bacteria and debris, and iron II and iron III and for chronic wounds proteases) will not pool on the wound bed and hinder wound healing, especially in a highly exuding wound. This is especially important in chronic wounds.

10

The resulting mixed exudate-irrigant fluid will usually be of relatively lower viscosity.

15

Because simultaneous aspiration and irrigation of the wound provides continuous removal at a constant relatively high speed, the fluid does not have to be accelerated cyclically from rest, and will be easier to shift than with known forms of aspiration and/or irrigation therapy systems with a conventional sequential aspirate – irrigate – dwell cycle.

20

This will thus exert a greater net effect on the removal of adherent bacteria and debris.

This is especially the case in those embodiments of the apparatus of this first aspect of the present invention for aspirating, irrigating and/or cleansing wounds where there is an inlet manifold (as described in further detail hereinafter) that covers and contacts most of the wound bed with openings that deliver the fluid directly to the wound bed over an extended area.

30

The present form of aspiration and/or irrigation therapy systems also often create a wound environment for better distribution of materials that are beneficial in some therapeutic aspect, in particular to wound healing,

35

that are present in a wound, but may not be well distributed in the wound, e.g. in a highly exuding wound (These include cytokines, enzymes, growth factors, cell matrix components, biological signalling molecules and other physiologically active components of the exudate.), and or
5 materials contained in the irrigant such as nutrients for wound cells to aid proliferation, and gases, such as oxygen.

These may aid wound cell proliferation and new tissue growth that has a strong three-dimensional structure adhering well to and growing from the
10 wound bed. This is a significant advantage, in particular in chronic wounds.

This is especially the case in those embodiments of the apparatus of this first aspect of the present invention for aspirating, irrigating and/or cleansing wounds where there is an inlet manifold as described below.
15 This covers and contacts most of the wound bed with openings that deliver the fluid directly to the wound bed over an extended area.

It will be seen that the balance of fluid between fluid aspirated from the wound and irrigant supplied to the wound from the irrigant reservoir may
20 provide a predetermined steady state concentration equilibrium of materials beneficial in promoting wound healing over the wound bed. Simultaneous aspiration of wound fluid and irrigation at a controlled flow rate aids in the attainment and maintenance of this equilibrium

25 The apparatus for irrigating and/or aspirating wounds of the present invention may be used cyclically and/or with reversal of flow.

Preferably the present apparatus for aspirating, irrigating and/or cleansing wounds is a conventionally automated, programmable system which can
30 cleanse the wound with minimal supervision.

The means for providing simultaneous aspiration and irrigation of the wound often comprises
a (first) device for moving fluid through the wound applied to fluid
35 downstream of and away from the wound dressing, in combination with at least one of

a second device for moving fluid through the wound applied to the irrigant in the fluid supply tube upstream of and towards the wound dressing; means for aspirate flow regulation, connected to a fluid offtake tube, and means for supply flow regulation, connected to a fluid supply tube;

5

The (first) device will apply negative pressure (i.e. below-atmospheric pressure or vacuum) to the wound bed. It may be applied to the aspirate in the fluid offtake tube downstream of and away from the wound dressing.

10 Alternatively or additionally, where appropriate, the aspirate in the fluid offtake tube downstream of the wound dressing may be aspirated into a collection vessel, and the first device may act on fluid such as air from the collection vessel.

15 The (first) device may be a fixed-throughput device, such as a fixed-speed pump, which will usually require a discrete means for aspirate flow regulation, connected to a fluid offtake tube, and/or means for supply flow regulation, connected to a fluid supply tube, in each case, e.g. a regulator, such as a rotary valve.

20

Alternatively, where appropriate the (first) device for moving fluid through the wound may be a variable-throughput device, such as a variable-speed pump, downstream of the wound dressing, thus effectively forming a combination of a (first) device for moving fluid through the wound with
25 means for aspirate flow regulation and/or means for supply flow regulation in a single integer.

The (first) device for moving fluid through the wound will often be a pump of any of the following types, or a piped supply of vacuum, applied to fluid
30 downstream of and away from the wound dressing. In the case of any pump it may be a fixed-speed pump, with (as above) a discrete means for aspirate flow regulation, connected to a fluid offtake tube, and/or means for supply flow regulation, connected to a fluid supply tube, in each case, e.g. a regulator, such as a rotary valve. Alternatively, where appropriate the
35 pump may be a variable-throughput or variable-speed pump.

The following types of pump may be used as the (first) device:

reciprocating pumps, such as piston pumps - where pistons pump fluids through check valves, in particular for positive and/or negative pressure on the wound bed; and

- 5 diaphragm pumps - where pulsations of one or two flexible diaphragms displace liquid with check valves.

and

rotary pumps, such as:

progressing cavity

- 10 pumps - with a cooperating screw rotor and stator, in particular for higher-viscosity and particulate-filled exudate; and

vacuum pumps - with pressure regulators.

- The (first) device may be a diaphragm pump, e.g. preferably a small
15 portable diaphragm pump. This is a preferred type of pump, in order in particular to reduce or eliminate contact of internal surfaces and moving parts of the pump with (chronic) wound exudate, and for ease of cleaning.

- Where the pump is a diaphragm pump, and preferably a small portable
20 diaphragm pump, the one or two flexible diaphragms that displace liquid may each be, for example a polymer film, sheet or membrane, that is connected to means for creating the pulsations. This may be provided in any form that is convenient, inter alia as a piezoelectric transducer, a core of a solenoid or a ferromagnetic integer and coil in which the direction of
25 current flow alternates, a rotary cam and follower, and so on.

- Where any second device is applied to the fluid in the fluid supply tube upstream of and towards the wound dressing, it will usually apply positive pressure (i.e. above-atmospheric pressure) to the wound bed.

30

As with the (first) device, it may be a fixed-throughput device, such as a fixed-speed pump, which will usually require a discrete means for supply flow regulation, connected to a fluid supply tube, e.g. a regulator, such as a rotary valve.

35

Alternatively, where appropriate the second device for moving irrigant fluid to the wound may be a variable-throughput device, such as a variable-speed pump, upstream of the wound dressing, thus effectively forming a combination of a second device for moving fluid through the wound with means for supply flow regulation in a single integer.

The second device for moving fluid through the wound will often be a pump of any of the following types applied to the irrigant in the fluid supply tube upstream of and towards the wound dressing. It may be a fixed-speed pump, with (as above) a discrete means for supply flow regulation, connected to a fluid supply tube, e.g. a regulator, such as a rotary valve. Alternatively, where appropriate the pump may be a variable-throughput or variable-speed pump.

- 15 The following types of pump may be used as the second device:
- reciprocating pumps, such as
 - shuttle pumps - with an oscillating shuttle mechanism to move fluids at rates from 2 to 50 ml per minute
 - and
 - 20 rotary pumps, such as:
 - centrifugal pumps
 - flexible impeller pumps - where elastomeric impeller traps fluid between impeller blades and a moulded housing that sweeps fluid through the pump housing.
 - 25 peristaltic pumps - with peripheral rollers on rotor arms acting on a flexible fluid aspiration tube to urge fluid current flow in the tube in the direction of the rotor.
 - rotary vane pumps - with rotating vaned disk attached to a drive shaft moving fluid without pulsation as it spins. The outlet can be restricted without damaging the pump.
 - 30

The second device may be a peristaltic pump, e.g. preferably a small portable peristaltic pump. This is a preferred type of pump, in order in particular to reduce or eliminate contact of internal surfaces and moving parts of the pump with irrigant, and for ease of cleaning.

Where the pump is a peristaltic pump, this may be e.g. an Instech Model P720 miniature peristaltic pump, with a flow rate: of 0.2 – 180ml/hr and a weight of < 0.5 k. This is potentially useful for home and field hospital use.

- 5 Each such pump of any these types may also suitably be one that is capable of pulsed, continuous, variable and/or automated and/or programmable fluid movement. Less usually and less preferably, each such pump of any these types will be reversible.
- 10 As above, the means for supply flow regulation may be a regulator, such as a rotary valve. This is connected between two parts of a fluid supply tube, such that the desired supply flow regulation is achieved.
- 15 If there are two or more inlet pipes, these may be connected to a single fluid supply tube with a single regulator, or to first, second, etc. fluid supply tubes, respectively having a first regulator, a second regulator, etc., e.g. a valve or other control device for admitting fluids into the wound.
- 20 As above, the means for aspirate flow regulation may be similarly provided in a form in which concomitant aspirate flow regulation is possible. It may be a regulator, such as a valve or other control device, e.g. a rotary valve.
- 25 Multiple offtake tubes may be similarly provided with single or multiple regulators, all for aspiration of fluids from the apparatus, e.g. to a aspirate collection vessel, such as a collection bag.
- 30 If there is no second device for moving fluid through the wound applied to the irrigant in the fluid supply tube upstream of and towards the wound dressing, it is only possible to apply a negative pressure to the wound, by means of the device for moving fluid through the wound applied to the aspirate in the fluid offtake tube downstream of and away from the wound dressing.

Operation may e.g. be carried out at a negative pressure of up to 50%atm., typically at a low negative pressure of up to 20% atm., more usually up to 10% atm. at the wound, as is described hereinafter.

- 5 Examples of suitable and preferred (first) devices include those types of pump that are so described hereinbefore in relation to the first device. This may be a diaphragm pump, e.g. preferably a small portable diaphragm pump. This is a preferred type of pump, in order in particular to reduce or eliminate contact of internal surfaces and moving parts of the pump with
10 (chronic) wound exudate, and for ease of cleaning.

Alternatively, if it is desired to apply a net positive pressure to the wound, the means for providing simultaneous aspiration and irrigation of the wound must comprise not only

- 15 a first device for moving fluid through the wound applied to the aspirate in the fluid offtake tube downstream of and away from the wound dressing, but also
a second device for moving fluid through the wound applied to the irrigant in the fluid supply tube upstream of and towards the wound dressing.

20

Operation may then e.g. be carried out at a positive pressure of up to 50%atm., typically at a low positive pressure of up to 20% atm., more usually up to 10% atm. at the wound, as is described hereinafter.

- 25 Examples of suitable and preferred first devices include those types of pump that are so described hereinbefore in relation to the first device. This may be a diaphragm pump, e.g. preferably a small portable diaphragm pump.

- 30 This is a preferred type of pump, in order in particular to reduce or eliminate contact of internal surfaces and moving parts of the pump with (chronic) wound exudate, and for ease of cleaning.

- Examples of suitable and preferred second devices include those types of
35 pump that are so described hereinbefore in relation to the second device. This may be a peristaltic pump, e.g. a miniature peristaltic pump.

This is a preferred type of pump, in order to eliminate contact of internal surfaces and moving parts of the pump with irrigant in the fluid supply tube upstream of and towards the wound dressing, and for ease of cleaning.

- 5 It is of course equally possible to apply a negative pressure to the wound, by means of such a combination of
a first device for moving fluid through the wound applied to the aspirate in the fluid offtake tube downstream of and away from the wound dressing, and
10 a second device for moving fluid through the wound applied to the irrigant in the fluid supply tube upstream of and towards the wound dressing;
optionally with
means for supply flow regulation, connected to a fluid supply tube;
means for aspirate flow regulation, connected to a fluid offtake tube.

- 15 Indeed, as noted below in this regard, preferred embodiments of the apparatus of this first aspect of the present invention for aspirating, irrigating and/or cleansing chronic wounds that apply a negative pressure include such types of combination of
20 a first device, e.g. a diaphragm pump, e.g. preferably a small portable diaphragm pump, and
a second device, e.g. a peristaltic pump, preferably a miniature peristaltic pump,
as described hereinbefore in relation to the device for moving fluid through
25 the wound.

- As noted above, either of the first device and the second device may be a fixed-throughput device, such as a fixed-speed pump, which will usually require a discrete means for aspirate flow regulation, connected to a fluid
30 offtake tube, and/or means for supply flow regulation, connected to a fluid supply tube, in each case, e.g. a regulator, such as a rotary valve, or
a variable-throughput device, such as a variable-speed pump, downstream of the wound dressing, thus effectively forming a combination of a (first)
device for moving fluid through the wound with means for aspirate flow
35 regulation and/or means for supply flow regulation in a single integer.

The higher end of the ranges of % positive and negative pressure noted above are potentially more suitable for hospital use, where they may only be used safely under professional supervision.

- 5 The lower end is potentially more suitable for home use, where relatively high % positive and negative pressures cannot be used safely without professional supervision, or for field hospital use.

10 In each case, the pressure on the wound may be held constant throughout the desired length of therapy, or may be varied cyclically in a desired positive or negative pressure regime.

15 As noted above, when it is desired to apply a negative pressure to the wound, it is preferred that the means for providing simultaneous aspiration and irrigation of the wound comprise not only
a (first) device for moving fluid through the wound applied to the aspirate in the fluid offtake tube downstream of and away from the wound dressing, but also
a second device for moving fluid through the wound applied to the irrigant in
20 the fluid supply tube upstream of and towards the wound dressing.

25 Accordingly, one embodiment of the apparatus for irrigating, cleansing and/or aspirating wounds of the present invention is characterised in the means for providing simultaneous aspiration and irrigation of the wound comprises
a (first) device for moving fluid through the wound applied to fluid downstream of and away from the wound dressing, and
a second device for moving fluid through the wound applied to the irrigant in the fluid supply tube upstream of and towards the wound dressing, and
30 in combination with at least one of
means for supply flow regulation, connected to a fluid supply tube, and
means for aspirate flow regulation, connected to a fluid offtake tube.

35 As noted above, either of the first device and the second device may be a fixed-throughput device, such as a fixed-speed pump, which will usually require a discrete

means for aspirate flow regulation, connected to a fluid offtake tube, and/or means for supply flow regulation, connected to a fluid supply tube, in each case, e.g. a regulator, such as a rotary valve, or

- 5 a variable-throughput device, such as a variable-speed pump, downstream of the wound dressing, thus effectively forming a combination of a (first) device for moving fluid through the wound with means for aspirate flow regulation and/or means for supply flow regulation in a single integer.
- 10 This combination of
- a) a device for moving fluid through the wound applied to the aspirate in the fluid offtake tube downstream of and away from the wound dressing, and
 - b) a device for moving fluid through the wound applied to the fluid in the
- 15 fluid supply tube upstream of and towards the wound dressing, may be used to apply an overall positive or negative, or even zero pressure to the wound.

- At least one body in the flow path to, over and from the wound bed should
- 20 have sufficient resilience against the pressure to allow any significant compression or decompression of the fluid occur.

- Thus, examples of suitable bodies include those which are or are defined by a film, sheet or membrane, such as inlet or offtake and/or tubes and
- 25 structures such as bags, chambers and pouches, filled with irrigant fluid, and e.g. the backing layer of the wound dressing, made of elastically resilient thermoplastic materials.

- It will be seen that the balance of fluid between aspirated fluid from the
- 30 wound and irrigant supplied to the wound from the fluid reservoir will thus be largely determined by a means for providing simultaneous aspiration and irrigation of the wound which is a system comprising:

- a) means for aspirate flow regulation and/or a device for moving fluid through the wound applied to fluid downstream of and away from the
- 35 wound dressing, and

b) means for supply flow regulation and/or a device for moving fluid through the wound applied to the fluid in the fluid supply tube upstream of and towards the wound dressing.

- 5 As noted above, either of the first device and the second device may be a fixed-throughput device, such as a fixed-speed pump, which will usually require a discrete means for aspirate flow regulation, connected to a fluid offtake tube, and/or means for supply flow regulation, connected to a fluid supply tube, in each case, e.g. a regulator, such as a rotary valve, or
- 10 a variable-throughput device, such as a variable-speed pump, downstream of the wound dressing, thus effectively forming a combination of a (first) device for moving fluid through the wound with means for aspirate flow regulation and/or means for supply flow regulation in a single integer.
- 15 The same means may be used to apply an overall positive or negative, or even neutral pressure to the wound.

The appropriate flow rate through the supply tube will depend on a number of factors, such as

20 the viscosity and consistency of each of the irrigant, exudate and mixed exudate-irrigant fluid, and any changes as the wound heals;

the level of negative pressure on the wound bed,

whether the irrigant in the fluid supply tube upstream of and into the wound dressing is under positive pressure, and the level of such pressure;

25 the level of any pressure drop between the irrigant in the fluid supply tube upstream of the wound dressing and the wound bed, such as across a porous element, e.g. a membrane wound contact layer on the lower surface of an inlet manifold that delivers the fluid directly to the wound bed; means for supply flow regulation; and/or a second device for moving fluid through

30 the wound applied to the fluid in the fluid supply tube upstream of and towards the wound dressing;

the depth and/or capacity of the wound and

the power consumption needed for a given desired fluid volume flow rate of irrigant and/or wound exudate through the wound.

The dressing may comprise an inlet manifold (as described in further detail hereinafter) that covers and contacts most of the wound bed with openings that deliver the fluid directly to the wound bed over an extended area, in the form of one or more inflatable hollow bodies defined by a film sheet or
5 membrane.

The (usually small) positive pressure above atmospheric from the irrigation device when both devices are running together should be sufficient to inflate the manifold.
10

The desired fluid volume flow rate of irrigant and/or wound exudate is preferably that for optimum performance of the wound healing process.

The flow rate will usually be in the range of 1 to 1500 ml/hr, such as 5 to
15 1000 ml/hr, e.g. 15 to 300 ml/hr, such as 35 to 200 ml/hr through the supply tube. The flow rate through the wound may be held constant throughout the desired length of therapy, or may be varied cyclically in a desired flow rate regime.

20 In practice, the offtake rate of flow of total irrigant and/or wound exudate will be of the order of 1 to 2000, e.g. 35 to 300 ml/24 hr/cm², where the cm² refers to the wound area, depending on whether the wound is in a highly exuding state.

25 In practice, the rate of exudate flow is only of the order of up to 75 microlitres / cm²/ hr (where cm² refers to the wound area), and the fluid can be highly mobile or not, depending on the level of proteases present). Exudate levels drop and consistency changes as the wound heals, e.g. to a level for the same wound that equates to 12.5 – 25 microlitres / cm² / hr.
30

It will be seen that the aspirated fluid from the wound will typically contain a preponderance of irrigant from the fluid reservoir over wound exudate.

The necessary adjustments to maintain the desired balance of fluid by
35 means of

a) the means for aspirate flow regulation and/or downstream device, and

b) the means for supply flow regulation and/or upstream device for moving fluid

will be apparent to the skilled person, bearing in mind that as noted above, either of the first device and the second device may be

- 5 a fixed-throughput device, such as a fixed-speed pump, which will usually require a discrete means for aspirate flow regulation, connected to a fluid offtake tube, and/or means for supply flow regulation, connected to a fluid supply tube, in each case, e.g. a regulator, such as a rotary valve, or
- 10 a variable-throughput device, such as a variable-speed pump, downstream of the wound dressing, thus effectively forming a combination of a (first) device for moving fluid through the wound with means for aspirate flow regulation and/or means for supply flow regulation in a single integer.

The type and/or capacity of

- 15 a suitable first device for moving fluid through the wound applied to the aspirate in the fluid offtake tube downstream of and away from the wound dressing and/or

a suitable second device for moving fluid through the wound applied to the irrigant in the fluid supply tube upstream of and towards the wound dressing

20 and/or

will be largely determined by

- a) the appropriate or desired fluid volume flow rate of irrigant and/or wound exudate from the wound, and
- b) whether it is appropriate or desired to apply a positive or negative
- 25 pressure to the wound bed, and the level of such pressure to the wound bed

for optimum performance of the wound healing process, and by factors such as portability, power consumption and isolation from contamination.

- 30 As noted above, when it is desired to apply a negative pressure to the wound with the apparatus of this first aspect of the present invention for aspirating, irrigating and/or cleansing wounds to provide simultaneous aspiration and irrigation of the wound, the means for providing simultaneous aspiration and irrigation of the wound may comprise

- 35 a single device for moving fluid through the wound applied to the aspirate in the fluid offtake tube downstream of and away from the wound dressing or

in combination with at least one of means for supply flow regulation, connected to a fluid supply tube, and means for aspirate flow regulation, connected to a fluid offtake tube.

- 5 As noted above, the device may be a fixed-throughput device, such as a fixed-speed pump, which will usually require a discrete means for aspirate flow regulation, connected to a fluid offtake tube, e.g. a regulator, such as a rotary valve, or a variable-throughput device, such as a variable-speed pump, downstream of the wound dressing, thus effectively forming a combination of a device for moving fluid through the wound with means for aspirate flow regulation in a single integer.

15 The operation of a typical apparatus of this type for simultaneous aspiration and irrigation of a wound at a low negative pressure of up to 20% atm., more usually up to 10% atm. at the wound, with one pump will now be described.

20 Before starting the apparatus of this first aspect of the present invention for aspirating, irrigating and/or cleansing wounds, the backing layer of the wound dressing is applied over the wound and conformed to the shape of the bodily part in which the wound is to form a relatively fluid-tight seal or closure.

25 The means for supply flow regulation, connected to a fluid supply tube, such as a regulator, such as a rotary valve, is usually closed, and the means for aspirate flow regulation (if any), connected to a fluid offtake tube, is opened.

30 The aspiration pump is started and run to give a negative pressure of up to 50% atm., more usually up to 20% atm., e.g. up to 10% atm. to be applied applies a vacuum to the interior of the dressing and the wound.

The means for fluid supply regulation is opened and is then adjusted, and/or where the aspiration pump is a variable-speed pump, downstream of the wound dressing, that is adjusted, to maintain the desired balance of fluid at a controlled nominal flow rate and to maintain the desired negative
5 pressure in the interior of the wound dressing.

The apparatus is then run for the desired length of therapy and with the desired negative pressure regime.

10 After this period, the aspiration pump is stopped.

The operation of a typical apparatus for simultaneous aspiration and irrigation of a wound at a low negative pressure of up to 20% atm., more
15 usually up to 10% atm. at the wound, with two pumps will now be described.

The necessary changes where the mode of operation is at a net positive pressure of e.g. up to 15% atm., more usually up to 10% atm. at the wound
20 will be apparent to the skilled person.

Such a typical apparatus for simultaneous aspiration and irrigation of a wound at a low negative pressure of up to 20% atm., more usually up to
25 10% atm. at the wound comprises means for providing simultaneous aspiration and irrigation of the wound which is a combination of

- a) a first device for moving fluid through the wound applied to the aspirate in the fluid offtake tube downstream of and away from the wound dressing, with optional means for aspirate flow regulation, connected to a fluid offtake tube: and
- 30 b) a second device for moving fluid through the wound applied to the irrigant in the fluid supply tube upstream of and towards the wound dressing, with optional means for supply flow regulation, connected to a fluid supply tube.

35 As noted above, either device may be

- a fixed-throughput device, such as a fixed-speed pump, which will usually require a discrete means for aspirate flow regulation, connected to a fluid offtake tube, e.g. a regulator, such as a rotary valve, or for irrigant flow regulation, connected to a fluid supply tube, either e.g. a regulator, such as
- 5 a rotary valve, or
a variable-throughput device, such as a variable-speed pump, thus effectively forming a combination of a device for moving fluid through the wound with means for flow regulation in a single integer.
- 10 Before starting the apparatus of this first aspect of the present invention for aspirating, irrigating and/or cleansing wounds, the backing layer of the wound dressing is applied over the wound and conformed to the shape of the bodily part in which the wound is to form a relatively fluid-tight seal or closure.
- 15 Any means for supply flow regulation, connected to a fluid supply tube, such as a regulator, such as a rotary valve, is usually closed, and any means for aspirate flow regulation, connected to a fluid offtake tube, is opened.
- 20 The aspiration pump is started and run to apply a negative pressure of up to 50% atm., more usually up to 20% atm., e.g. up to 10% atm., to the interior of the dressing and the wound.
- 25 The irrigation pump is then started, so that both pumps are running together, and any means for supply flow regulation is opened.
- The irrigation pump flow rate and any means for fluid supply regulation are then adjusted and/or where the aspiration pump and/or the irrigation pump
- 30 is a variable-speed pump, either or both is/are is adjusted, to maintain the desired balance of fluid at a controlled nominal flow rate and to maintain the desired negative pressure in the interior of the wound dressing.
- The apparatus is then run for the desired length of therapy and with the
- 35 desired pressure regime.

After this period, the irrigation pump is stopped, shortly followed by the aspiration pump.

- 5 In all embodiments of the apparatus of this first aspect of the present invention for aspirating, irrigating and/or cleansing wounds, a particular advantage is the tendency of the wound dressing to conform to the shape of the bodily part to which it is applied.
- 10 The wound dressing comprises a backing layer with a wound-facing face which is capable of forming a relatively fluid-tight seal or closure over a wound and
at least one inlet pipe for connection to a fluid supply tube or tube, which passes through and/or under the wound-facing face, and
15 and at least one outlet pipe for connection to a fluid offtake tube, which passes through and/or under the wound-facing face,
the point at which the or each inlet pipe and the or each outlet pipe passes through and/or under the wound-facing face forming a relatively fluid-tight seal or closure.
- 20 The term 'relatively fluid-tight seal or closure' is used herein to indicate one which is fluid- and microbe-impermeable and permits a positive or negative pressure of up to 50% atm., more usually up to 20% atm., e.g. up to 10% atm. to be applied to the wound. The term 'fluid' is used herein to include
25 gels, e.g. thick exudate, liquids, e.g. water, and gases, such as air, nitrogen, etc.
- The shape of the backing layer that is applied may be any that is appropriate to aspirating, irrigating and/or cleansing the wound across the
30 area of the wound.
- Examples of such include a substantially flat film, sheet or membrane, or a bag, chamber, pouch or other structure of the backing layer, e.g. of polymer film, which can contain the fluid.

The backing layer may be a film, sheet or membrane, often with a (generally uniform) thickness of up to 100 micron, preferably up to 50 micron, more preferably up to 25 micron, and of 10 micron minimum thickness.

5

Its largest cross-dimension may be up to 500 mm (for example for large torso wounds), up to 100 mm (for example for axillary and inguinal wounds), and up to 200 mm for limb wounds (for example for chronic wounds, such as venous leg ulcers and diabetic foot ulcers).

10

Desirably the dressing is resiliently deformable, since this may result in increased patient comfort, and lessen the risk of inflammation of a wound.

Suitable materials for it include synthetic polymeric materials that do not absorb aqueous fluids, such as polyolefins, such as polyethylene e.g. high-density polyethylene, polypropylene, copolymers thereof, for example with vinyl acetate and polyvinyl alcohol, and mixtures thereof; polysiloxanes; polyesters, such as polycarbonates; polyamides, e.g. 6-6 and 6 - 10, and hydrophobic polyurethanes.

20

They may be hydrophilic, and thus also include hydrophilic polyurethanes.

They also include thermoplastic elastomers and elastomer blends, for example copolymers, such as ethyl vinyl acetate, optionally or as necessary blended with high-impact polystyrene.

25

They further include elastomeric polyurethane, particularly polyurethane formed by solution casting.

Preferred materials for the present wound dressing include thermoplastic elastomers and curable systems.

30

The backing layer is capable of forming a relatively fluid-tight seal or closure over the wound and/or around the inlet and outlet pipe(s).

35

However, in particular around the periphery of the wound dressing, outside the relatively fluid-tight seal, it is preferably of a material that has a high moisture vapour permeability, to prevent maceration of the skin around the wound. It may also be a switchable material that has a higher moisture vapour permeability when in contact with liquids, e.g. water, blood or wound exudate. This may, e.g. be a material that is used in Smith & Nephew's Allewyn™, IV3000™ and OpSite™ dressings.

The periphery of the wound-facing face of the backing layer may bear an adhesive film, for example, to attach it to the skin around the wound.

This may, e.g. be a pressure-sensitive adhesive, if that is sufficient to hold the wound dressing in place in a fluid-tight seal around the periphery of the wound-facing face of the wound dressing.

Alternatively or additionally, where appropriate a light switchable adhesive could be used to secure the dressing in place to prevent leakage. (A light switchable adhesive is one the adhesion of which is reduced by photocuring. Its use can be beneficial in reducing the trauma of removal of the dressing.)

Thus, the backing layer may have a flange or lip extending around the proximal face of the backing layer, of a transparent or translucent material (for which it will be understood that materials that are listed above are amongst those that are suitable).

This bears a film of a light switchable adhesive to secure the dressing in place to prevent leakage on its proximal face, and a layer of opaque material on its distal face.

To remove the dressing and not cause excessive trauma in removal of the dressing, the layer of opaque material on the distal face of the flange or lip extending around the proximal wound is removed prior to application of radiation of an appropriate wavelength to the flange or lip.

35

If the periphery of the wound dressing, outside the relatively fluid-tight seal, that bears an adhesive film to attach it to the skin around the wound, is of a material that has a high moisture vapour permeability or is a switchable material, then the adhesive film, if continuous, should also have a high or switchable moisture vapour permeability, e.g. be an adhesive such as used in Smith & Nephew's Allevyn™, IV3000™ and OpSite™ dressings.

Where a vacuum is applied to hold the wound dressing in place in a fluid-tight seal around the periphery of the wound-facing face of the wound dressing, the wound dressing may be provided with a silicone flange or lip to seal the dressing around the wound. This removes the need for adhesives and associated trauma to the patient's skin.

Where the interior of, and the flow of irrigant and/or wound exudate to and through, the dressing is under any significant positive pressure, which will tend to act at peripheral points to lift and remove the dressing off the skin around the wound.

In such use of the apparatus, it may thus be necessary to provide means for forming and maintaining such a seal or closure over the wound against such positive pressure on the wound, to act at peripheral points for this purpose.

Examples of such means include light switchable adhesives, as above, to secure the dressing in place to prevent leakage.

Since the adhesion of a light switchable adhesive is reduced by photocuring, thereby reducing the trauma of removal of the dressing, a film of a more aggressive adhesive may be used, e.g. on a flange, as above.

Examples of suitable fluid adhesives for use in more extreme conditions where trauma to the patient's skin is tolerable include ones that consist essentially of cyanoacrylate and like tissue adhesives, applied around the edges of the wound and/or the proximal face of the backing layer of the wound dressing, e.g. on a flange or lip.

Further suitable examples of such means include adhesive (e.g. with pressure-sensitive adhesive) and non-adhesive, and elastic and non-elastic straps, bands, loops, strips, ties, bandages, e.g. compression bandages, sheets, covers, sleeves, jackets, sheathes, wraps, stockings and hose, e.g. elastic tubular hose or elastic tubular stockings that are a compressive fit over a limb wound to apply suitable pressure to it when the therapy is applied in this way; and inflatable cuffs, sleeves, jackets, trousers, sheathes, wraps, stockings and hose that are a compressive fit over a limb wound to apply suitable pressure to it when the therapy is applied in this way.

Such means may each be laid out over the wound dressing to extend beyond the periphery of the backing layer of the wound dressing, and as appropriate will be adhered or otherwise secured to the skin around the wound and/or itself and as appropriate will apply compression (e.g. with elastic bandages, stockings) to a degree that is sufficient to hold the wound dressing in place in a fluid-tight seal around the periphery of the wound,

Such means may each be integral with the other components of the dressing, in particular the backing layer.

Alternatively, it may be permanently attached or releasably attached to the dressing, in particular the backing layer, with an adhesive film, for example, or these components may be a Velcro™, push snap or twist-lock fit with each other.

The means and the dressing may be separate structures, permanently unattached to each other.

In a more suitable layout for higher positive pressures on the wound, a stiff flange or lip extends around the periphery of the proximal face of the backing layer of the wound dressing as hereinbefore defined.

The flange or lip is concave on its proximal face to define a peripheral channel or conduit.

It has a suction outlet that passes through the flange or lip to communicate with the channel or conduit and may be connected to a device for applying a vacuum, such as a pump or a piped supply of vacuum.

- 5 The backing layer may be integral with or attached, for example by heat-sealing, to the flange or lip extending around its proximal face.
To form the relatively fluid-tight seal or closure over a wound that is needed and to prevent passage of irrigant and/or exudate under the periphery of the wound-facing face of the wound dressing, in use of the apparatus, the
10 dressing is set on the skin around the wound.

The device then applies a vacuum to the interior of the flange or lip, thus forming and maintaining a seal or closure acting at peripheral points around the wound against the positive pressure on the wound.

- 15 With all the foregoing means of attachment, and means for forming and maintaining a seal or closure over the wound, against positive or negative pressure on the wound at peripheral points around the wound, the wound dressing sealing periphery is preferably of a generally round shape, such as
20 an ellipse, and in particular circular.

- To form the relatively fluid-tight seal or closure over a wound and around the inlet pipe(s) and outlet pipe(s) at the point at which they pass through and/or under the wound-facing face, the backing layer may be integral with
25 these other components.

The components may alternatively just be a push, snap or twist-lock fit with each other, or adhered or heat-sealed together.

- 30 The or each inlet pipe or outlet pipe may be in the form of an aperture, such as a funnel, hole, opening, orifice, luer, slot or port for connection as a female member respectively to a mating end of
a fluid tube and/or fluid supply tube (optionally or as necessary via means for forming a tube, pipe or hose, or nozzle, hole, opening, orifice, luer, slot
35 or port for connection as a male member respectively to a mating end of

a fluid tube and/or fluid supply tube (optionally or as necessary via means for supply flow regulation) or
a fluid offtake tube.

- 5 Where the components are integral they will usually be made of the same material (for which it will be understood that materials that are listed above are amongst those that are suitable).

10 Where, alternatively, they are a push, snap or twist-lock fit, they may be of the same material or of different materials. In either case, materials that are listed above are amongst those that are suitable for all the components.

15 The or each pipe will generally pass through, rather than under the backing layer. In such case, the backing layer may often have a rigid and/or resiliently inflexible or stiff area to resist any substantial play between the or each pipe and the or each mating tube, or deformation under pressure in any direction.

20 It may often be stiffened, reinforced or otherwise strengthened by a boss projecting distally (outwardly from the wound) around each relevant tube, pipe or hose, or nozzle, hole, opening, orifice, luer, slot or port for connection to a mating end of a fluid tube and/or fluid supply tube or fluid offtake tube.

25 Alternatively or additionally, where appropriate the backing layer may have a stiff flange or lip extending around the proximal face of the backing layer to stiffen, reinforce or otherwise strengthen the backing layer.

30 The wound dressing may not comprise any integer under the backing layer in the wound in use.

35 However, this may not provide a system to distribute irrigant over a sufficient functional surface area to irrigate the wound at a practical rate to be suitable for use, in particular in chronic wound aspiration and irrigation, with relatively high concentrations of materials that are deleterious to wound healing.

It may be advantageous to provide a system where wound irrigant may be distributed more evenly, or pass in a more convoluted path under the dressing over the wound bed.

5

Accordingly, one form of the dressing is provided with a 'tree' form of pipes, tubes or tubules that radiate from an inlet manifold to the wound bed to end in apertures and deliver the aspirating fluid directly to the wound bed via the apertures. Similarly, there is an outlet manifold from which tubules radiate and run to the wound bed to end in openings and collect the fluid directly from the wound bed.

10

The pipes, etc. may radiate regularly or irregularly through the wound in use, respectively from the inlet or outlet manifold, although regularly may be preferred. A more suitable layout for deeper wounds is one in which the pipes, etc. radiate hemispherically and concentrically, to the wound bed.

15

For shallower wounds, examples of suitable forms of such layout of the pipes, etc. include ones in which the pipes, etc. radiate in a flattened hemiellipsoid and concentrically, to the wound bed.

20

Other suitable forms of layout of the pipes, etc. include one which have pipes, tubes or tubules extending from the inlet pipe(s) and/or outlet pipe(s) at the point at which they pass through and/or under the wound-facing face of the backing layer to run over the wound bed. These may have a blind bore with perforations, apertures, holes, openings, orifices, slits or slots along the pipes, etc.

25

These pipes, etc. then effectively form an inlet pipe manifold that delivers the aspirating fluid directly to the wound bed or outlet pipe or collects the fluid directly from the wound respectively.

30

It does so via the holes, openings, orifices, slits or slots in the tubes, pipes, tubules, etc. over most of the wound bed under the backing layer.

35

It may be desirable that the tubes, pipes or tubules are resiliently flexible, e.g. elastomeric, and preferably soft, structures with good conformability in the wound and the interior of the wound dressing.

- 5 When the therapy is applied in this way, the layout of the tubes, pipes, tubules, etc. may depend on the depth and/or capacity of the wound.

Thus, for shallower wounds, examples of suitable forms of such layout of the tubes, pipes, tubules, etc. include ones that consist essentially of one or more of the tubes, etc in a spiral.

10

A more suitable layout for deeper wounds when the therapy is applied in this way may be one which comprises one or more of the tubes, etc in a helix or spiral helix.

- 15 Other suitable layouts for shallower wounds include one which have blind-bore, perforated inlet pipe or outlet pipe manifolds that aspirate fluid in the wound when the dressing is in use.

20 One or both of these may be such a form, the other may be, e.g. one or more straight blind-bore, perforated radial tubes, pipes or nozzles.

A preferred form of inlet pipe (or less usually) outlet pipe manifold that delivers the aspirating fluid directly to the wound bed or collects the fluid directly from the wound respectively is one that comprise one or more
25 conformable hollow bodies defined by a film, sheet or membrane, such as a bag, chamber, pouch or other structure, filled with the irrigant (or less usually) aspirate from the wound, passing through perforations, apertures, holes, openings, orifices, slits or slots in the film, sheet or membrane defining the hollow body or hollow bodies.

30

These may be of small cross-dimension, so that they may then effectively form microperforations, microapertures or pores in a permeable integer, for example the polymer film, sheet or membrane.

35

This type of manifold for irrigation (more usually) provides the highest uniformity in the flow distribution of irrigant over the wound at a practical rate to be suitable for use, in particular in chronic wound aspiration and irrigation, and hence to provide a system where materials that are beneficial in promoting wound healing, such as growth factors, cell matrix components, and other physiologically active components of the exudate from a wound, are distributed more evenly under the dressing over the wound bed.

10 This type of manifold for irrigation (more usually) is noted below with regard to wound fillers under the backing layer, since it is a resiliently flexible, e.g. elastomeric, and soft, structure with good conformability to wound shape. It is urged by its own resilience against the backing layer to apply gentle pressure on the wound bed, and is therefore also capable of acting as a wound filler. The film, sheet or membrane, often has a (generally uniform) thickness similar to that of films or sheets used in conventional wound dressing backing layers.

Another suitable layout is one in which
20 an inlet pipe and/or outlet pipe manifold that delivers the aspirating fluid directly to the wound bed or collects the fluid directly from the wound respectively
via inlet and/or outlet tubes, pipes or tubules,
and the inlet manifold and/or outlet manifold is formed by slots in layers permanently attached to each other in a stack, and
25 the inlet and/or outlet tubes, pipes or tubules are formed by apertures through layers permanently attached to each other in a stack. (In Figure 10a there is shown an exploded isometric view of such a stack, which is non-limiting.)

30

As also mentioned herein, the backing layer that is applied may be any that is appropriate to the present system of therapy and permits a positive or negative pressure of up to 50% atm., more usually up to 25% atm. to be applied to the wound.

35

It is thus often a microbe-impermeable film, sheet or membrane, which is substantially flat, depending on any pressure differential on it, and often with a (generally uniform) thickness similar to such films or sheets used in conventional wound dressings, i.e. up to 100 micron, preferably up to 50
5 micron, more preferably up to 25 micron, and of 10 micron minimum thickness.

The backing layer may often have a rigid and/or resiliently inflexible or stiff area to resist any substantial play between other components that are not
10 mutually integral, and may be stiffened, reinforced or otherwise strengthened, e.g. by a projecting boss.

Such a form of dressing would not be very conformable to the wound bed, and may effectively form a chamber, hollow or cavity defined by a backing
15 layer and the wound bed under the backing layer.

It may be desirable that the interior of the wound dressing conform to the wound bed, even for a wound in a highly exuding state. Accordingly, one form of the dressing is provided with a wound filler under the backing layer.
20

This is favourably a resiliently flexible, e.g. elastomeric, and preferably soft, structure with good conformability to wound shape.

It is urged by its own resilience against the backing layer to apply gentle
25 pressure on the wound bed.

The wound filler may be integral with the other components of the dressing, in particular the backing layer.

30 Alternatively, it may be permanently attached to them/it, with an adhesive film, for example, or by heat-sealing, e.g. to a flange or lip extending from the proximal face, so as not to disrupt the relatively fluid-tight seal or closure over the wound that is needed.

Less usually, the wound filler is releasably attached to the backing layer, with an adhesive film, for example, or these components may be a push, snap or twist-lock fit with each other.

- 5 The wound filler and the backing layer may be separate structures, permanently unattached to each other.

10 The wound filler may be or comprise a solid integer, favourably a resiliently flexible, e.g. elastomeric, and preferably soft, structure with good conformability to wound shape.

Examples of suitable forms of such wound fillers are foams formed of a suitable material, e.g. a resilient thermoplastic.

15 Preferred materials for the present wound dressing include reticulated filtration polyurethane foams with small apertures or pores.

20 Alternatively or additionally, it may be in the form of, or comprise one or more conformable hollow bodies defined by a film, sheet or membrane, such as a bag, chamber, pouch or other structure, filled with a fluid or solid that urges it to the wound shape.

The film, sheet or membrane, often has a (generally uniform) thickness similar to that of films or sheets used in conventional wound dressing backing layers.

25

That is, up to 100 micron, preferably up to 50 micron, more preferably up to 25 micron, and of 10 micron minimum thickness, and is often resiliently flexible, e.g. elastomeric, and preferably soft.

30 Such a filler is often integral with the other components of the dressing, in particular the backing layer, or permanently attached to them/it, with an adhesive film, for example, or by heat-sealing, e.g. to a flange

35

Examples of suitable fluids contained in the hollow body or bodies defined by a film, sheet or membrane include gases, such as air, nitrogen and argon, more usually air, at a small positive pressure above atmospheric; and liquids, such as water, saline.

5

Examples also include gels, such as silicone gels, e.g. CaviCare™ gel, or preferably cellulosic gels, for example hydrophilic cross-linked cellulosic gels, such as Intrasite™ cross-linked materials.

10 Examples also include aerosol foams, where the gaseous phase of the aerosol system is air or an inert gas, such as nitrogen or argon, more usually air, at a small positive pressure above atmospheric; and solid particulates, such as plastics crumbs.

15 Of course, if the backing layer is a sufficiently conformable and/or e.g. an upwardly dished sheet, the backing layer may lie under the wound filler, rather than vice versa.

20 In this type of layout, in order for the wound filler to urge the wound dressing towards the wound bed, it will usually have to be firmly adhered or otherwise releasably attached to the skin around the wound. This is especially the case in those embodiments where the wound filler and the backing layer are separate structures, permanently unattached to each other.

25

In such a layout for deeper wounds when the therapy is applied in this way, the means for such attachment may also form and maintain a seal or closure over the wound.

30 Where the filler is over the backing layer, and the fluid inlet pipe(s) and outlet pipe(s) pass through the wound-facing face of the backing layer, they may run through or around the wound filler over the backing layer.

35

One form of the dressing is provided with a wound filler under the backing layer that is or comprises a resiliently flexible, e.g. elastomeric, and preferably soft, hollow body defined by a film, sheet or membrane, such as a bag, chamber, pouch or other structure.

5

It has apertures, holes, openings, orifices, slits or slots, or tubes, pipes, tubules or nozzles. It communicates with at least one inlet or outlet pipe through at least one aperture, hole, opening, orifice, slit or slot.

10 The fluid contained in the hollow body may then be the aspirating fluid in the apparatus.

The hollow body or each of the hollow bodies then effectively forms an inlet pipe or outlet pipe manifold that delivers the aspirating fluid directly to the wound bed or collects the fluid directly from the wound respectively via the holes, openings, orifices, slits or slots, or the tubes, pipes or hoses, etc. in the film, sheet or membrane.

20 When the therapy is applied in this way, the type of the filler may also be largely determined by the depth and/or capacity of the wound.

Thus, for shallower wounds, examples of suitable wound fillers as a component of a wound dressing include ones that consist essentially of one or more conformable hollow bodies defining an inlet pipe and/or outlet pipe manifold that delivers the aspirating fluid directly to the wound bed or collects the fluid directly from the wound.

30 A more suitable wound filler for deeper wounds when the therapy is applied in this way may be one which comprises one or more conformable hollow bodies defined by, for example a polymer film, sheet or membrane, that at least partly surround(s) a solid integer. This may provide a system with better rigidity for convenient handling.

35 The wound filler under the backing layer may effectively form an inlet pipe or outlet pipe manifold,

If not, in order for aspiration and/or irrigation of the wound bed to occur, it is appropriate for one or more bores, channels, conduits, passages, pipes, tubes, tubules and/or spaces, etc. to run from the point at which the fluid inlet pipe(s) and outlet pipe(s) pass through and/or under the wound-facing
5 face of the backing layer through or around the wound filler under the backing layer.

Less usually, the wound filler is an open-cell foam with pores that may form such bores, channels, conduits, passages and/or spaces through the
10 wound filler under the backing layer.

Where the filler is or comprises one or more conformable hollow bodies defined by, for example a polymer film, sheet or membrane, it may be provided with means for admitting fluids to the wound bed under the wound
15 dressing.

These may be in the form of pipes, tubes, tubules or nozzles running from the point at which the fluid inlet pipe(s) and outlet pipe(s) pass through and/or under the wound-facing face of the backing layer through or around
20 the wound filler under the backing layer.

All of the suitable layouts for shallower wounds that comprise blind-bore, perforated inlet pipe or outlet pipe manifolds that aspirate fluid in the wound when the dressing is in use, that are described hereinbefore, may be used
25 under a wound filler under the backing layer.

In brief, suitable layouts include ones where one or both manifolds are annular or toroidal (regular, e.g. elliptical or circular or irregular), optionally with blind-bore, perforated radial tubes, pipes or nozzles, branching from
30 the annulus or torus; and/or
in a meandering, tortuous, winding, zigzag, serpentine or boustrophedonic (i.e. in the manner of a ploughed furrow) pattern, or
defined by slots in and apertures through layers attached to each other in a
stack.

35

The inlet and/or outlet tubes, the fluid tube and the fluid supply tube, etc. may be of conventional type, e.g. of elliptical or circular cross-section, and may suitably have a uniform cylindrical bore, channel, conduit or passage throughout their length, and suitably the largest cross-dimension of the bore
5 may be up to 10 mm for large torso wounds, and up to 2 mm for limb wounds.

The tube walls should suitably thick enough to withstand any positive or negative pressure on them. However, the prime purpose of such tubes is
10 to convey fluid irrigant and exudate through the length of the apparatus flow path, rather than to act as pressure vessels.

The tube walls may suitably be at least 25 micron thick.

15 The bore or any perforations, apertures, holes, openings, orifices, slits or slots along the pipes, etc. or in the hollow body or each of the hollow bodies may be of small cross-dimension.

They may then effectively form a macroscopic and/or microscopic filter for
20 particulates including cell debris and micro-organisms, whilst allowing proteins and nutrients to pass through.

Such tubes, pipes or hoses, etc. through and/or around the filler, whether the latter is a solid integer and/or one or more resiliently flexible or
25 conformable hollow bodies, are described in further detail hereinbefore in connection with the inlet pipe(s) and outlet pipe(s).

The whole length of the apparatus for aspirating, irrigating and/or cleansing wounds should be microbe-impermeable once the wound dressing is over
30 the wound in use.

It is desirable that the wound dressing and the interior of the apparatus for aspirating, irrigating and/or cleansing wounds of the present invention is
sterile.

35

The fluid may be sterilised in the fluid reservoir and/or the rest of the system in which the fluid moves by ultraviolet, gamma or electron beam irradiation.

- 5 This way, in particular reduces or eliminates contact of internal surfaces and the fluid with any sterilising agent.

Examples of other methods of sterilisation of the fluid also include e.g. the use of

- 10 ultrafiltration through microapertures or micropores, e.g. of 0.22 to 0.45 micron maximum cross-dimension, to be selectively impermeable to microbes; and
fluid antiseptics, such as solutions of chemicals, such as chlorhexidine and povidone iodine; metal ion sources, such as silver salts, e.g. silver nitrate;
15 and hydrogen peroxide;
although the latter involve contact of internal surfaces and the fluid with the sterilising agent.

- 20 It may be desirable that the interior of the wound dressing, the rest of the system in which the fluid moves, and/or the wound bed, even for a wound in a highly exuding state, are kept sterile after the fluid is sterilised in the fluid reservoir, or that at least naturally occurring microbial growth is inhibited.

- 25 Thus, materials that are potentially or actually beneficial in this respect may be added to the irrigant initially, and as desired the amount is increased by continuing addition.

- 30 Examples of such materials include antibacterial agents (some of which are listed above), and antifungal agents.

Amongst those that are suitable are, for example triclosan, iodine, metronidazole, cetrimide, chlorhexidine acetate, sodium undecylenate, chlorhexidine and iodine.

Buffering agents, such as potassium dihydrogen phosphate/ disodium hydrogen phosphate. may be added to adjust the pH, as may local analgesics/anaesthetics, such as lidocaine/lignocaine hydrochloride, xylocaine (adrenoline, lidocaine) and/or anti-inflammatories, to reduce wound pain or inflammation or pain associated with the dressing.

In order to combat the deposition of materials in the flow path from the irrigant, a repellent coating may be used at any point or on any integer in the path in direct contact with the fluid, e.g. on the means for providing simultaneous aspiration and irrigation of the wound or any desired tube or pipe.

Examples of coating materials for surfaces over which the aspirating fluid passes include

anticoagulants, such as heparin, and high surface tension materials, such as PTFE, and polyamides, which are useful for growth factors, enzymes and other proteins and derivatives.

The apparatus of the invention for aspirating, irrigating and/or cleansing wounds is provided with means for admitting fluids directly or indirectly to the wound under the wound dressing in the form of a fluid supply tube to a fluid reservoir.

The fluid reservoir may be of any conventional type, e.g. a tube, bag (such as a bag typically used for blood or blood products, e.g. plasma, or for infusion feeds, e.g. of nutrients), chamber, pouch or other structure, e.g. of polymer film, which can contain the irrigant fluid.

The reservoir may be made of a film, sheet or membrane, often with a (generally uniform) thickness similar to that of films or sheets used in conventional wound dressing backing layers, i.e. up to 100 micron, preferably up to 50 micron, more preferably up to 25 micron, and of 10 micron minimum thickness, and is often a resiliently flexible, e.g. elastomeric, and preferably soft, hollow body.

In all embodiments of the apparatus the type and material of the tubes throughout the apparatus of the invention for aspirating, irrigating and/or cleansing wounds and the fluid reservoir will be largely determined by their function.

5

To be suitable for use, in particular on chronic timescales, the material should be non-toxic and biocompatible, inert to any active components, as appropriate of the irrigant from the fluid reservoir and/or wound exudate in the apparatus flow path, and, in any use of a two-phase system aspiration and irrigation unit, of the dialysate that moves into the aspirating fluid in the apparatus.

10

When in contact with irrigant fluid, it should not allow any significant amounts of extractables to diffuse freely out of it in use of the apparatus.

15

It should be sterilisable by ultraviolet, gamma or electron beam irradiation and/or with fluid antiseptics, such as solutions of chemicals, fluid- and microbe-impermeable once in use, and flexible.

20

Examples of suitable materials for the fluid reservoir include synthetic polymeric materials, such as polyolefins, such as polyethylene, e.g. high-density polyethylene and polypropylene.

25

Suitable materials for the present purpose also include copolymers thereof, for example with vinyl acetate and mixtures thereof. Suitable materials for the present purpose further include medical grade poly(vinyl chloride).

30

Notwithstanding such polymeric materials, the fluid reservoir will often have a stiff area to resist any substantial play between it and components that are not mutually integral, such as the fluid supply tube towards the wound dressing, and may be stiffened, reinforced or otherwise strengthened, e.g. by a projecting boss.

35

Materials deleterious to wound healing that are removed include oxidants, such as free radicals, e.g. peroxide and superoxide;

iron II and iron III;
all involved in oxidative stress on the wound bed;
proteases, such as serine proteases, e.g. elastase and thrombin; cysteine
proteases; matrix metalloproteases, e.g. collagenase; and carboxyl (acid)
5 proteases;
endotoxins, such as lipopolysaccharides;
autoinducer signalling molecules, such as homoserine lactone derivatives,
e.g. oxo-alkyl derivatives;
inhibitors of angiogenesis such as thrombospondin-1 (TSP-1), plasminogen
10 activator inhibitor, or angiostatin (plasminogen fragment);
pro-inflammatory cytokines such as tumour necrosis factor alpha (TNF α)
and interleukin 1 beta (IL-1 β),
oxidants, such as free radicals, e.g. , e.g. peroxide and superoxide; and
metal ions, e.g. iron II and iron III, all involved in oxidative stress on the
15 wound bed.

It is believed that aspirating wound fluid aids in removal from of the
materials deleterious to wound healing from wound exudate and/or irrigant,
whilst distributing materials that are beneficial in promoting wound healing
20 in contact with the wound.

A steady state concentration equilibrium of materials beneficial in promoting
wound healing may be set up between in the irrigant and/or wound
exudate.

25 Aspirating wound fluid aids in the quicker attainment of this equilibrium

Materials beneficial to wound healing that are distributed include cytokines,
enzymes, growth factors, cell matrix components, biological signalling
30 molecules and other physiologically active components of the exudate.
and/or

materials in the irrigant that are potentially or actually beneficial in respect
of wound healing, such as nutrients for wound cells to aid proliferation,
gases, such as oxygen.

35

The conduits through which respectively the irrigant and/or wound exudate passes to and from the wound dressing and

- i) may have means for modular disconnection and withdrawal of the dressing,
- 5 ii) providing an immediate fluid-tight seal or closure over the ends of the conduits and the cooperating tubes in the rest of the apparatus of the invention so exposed,
to prevent continuing passage of irrigant and/or exudate.

- 10 The outlet from the means for aspirate flow regulation and/or tubes may be collected and monitored and used to diagnose the status of the wound and/or its exudate.

Any aspirate collection vessel may be of any conventional type, e.g. a tube,
15 bag (such as a bag typically used as an ostomy bag), chamber, pouch or other structure, e.g. of polymer film, which can contain the irrigant fluid that has been bled off. In all embodiments of the apparatus, the type and material of the aspirate collection vessel will be largely determined by its function.

20 To be suitable for use, the material need only be fluid-impermeable once in use, and flexible.

Examples of suitable materials for the fluid reservoir include synthetic
25 polymeric materials, such as polyolefins, such as poly (vinylidene chloride).

Suitable materials for the present purpose also include polyethylene, e.g. high-density polyethylene, polypropylene, copolymers thereof, for example with vinyl acetate and mixtures thereof.

30 In a second aspect of the present invention there is provided a conformable wound dressing, characterised in that it comprises a backing layer with a wound-facing face which is capable of forming a relatively fluid-tight seal or closure over a wound and has
35 at least one inlet pipe for connection to a fluid supply tube, which passes through and/or under the wound-facing face, and

at least one outlet pipe for connection to a fluid offtake tube, which passes through and/or under the wound-facing face, the point at which the or each inlet pipe and the or each outlet pipe passes through and/or under the wound-facing face forming a relatively fluid-tight seal or closure over the wound.

The dressing is advantageously provided for use in a bacteria-proof pouch.

Examples of suitable forms of such wound dressings are as described by way of example hereinbefore.

In a third aspect of the present invention there is provided a method of treating wounds to promote wound healing using the apparatus for aspirating, irrigating and/or cleansing wounds of the present invention.

The present invention will now be described by way of example only with reference to the accompanying drawings in which:

Figure 1 is a schematic view of an apparatus for aspirating, irrigating and/or cleansing a wound according to the first aspect of the present invention that has

a single device for moving fluid through the wound applied to the aspirate in the fluid offtake tube downstream of and away from the wound dressing, in combination with means for supply flow regulation, connected to a fluid supply tube, and means for aspirate flow regulation, connected to a fluid offtake tube.

Figure 2 is a schematic view of another apparatus for aspirating, irrigating and/or cleansing a wound according to the first aspect of the present invention that has

a first device for moving fluid through the wound applied to the aspirate in the fluid offtake tube downstream of and away from the wound dressing, with means for aspirate flow regulation, connected to a fluid offtake tube; and a second device for moving fluid through the wound applied to the irrigant in the fluid supply tube upstream of and towards the wound dressing.

Figures 3 to 7 are cross-sectional views of conformable wound dressings, of the second aspect of the present invention for aspirating and/or irrigating wounds.

5 In these, Figures 3a to 6a are cross-sectional plan views of the wound dressings, and Figures 3b to 6b are cross-sectional side views of the wound dressings.

10 Figures 8 to 10 are various views of inlet and outlet manifold layouts for the wound dressings of the second aspect of the present invention for respectively delivering fluid to, and collecting fluid from, the wound.

15 Figures 11A to D are variants of a two-pump system with essentially identical, and identically numbered, components as in Figure 2, except that there is a pump bypass loop, except in Figure 11C.

20 a filter downstream of the aspirate collection vessel, and a bleed regulator, such as a rotary valve, connected to the fluid offtake tube or to the wound space, for the regulation of the positive or negative pressure applied to the wound.

25 Figures 12A to C are variants of a two-pump system with essentially identical, and identically numbered, components as in Figures 11, except that they have various means for varying the regulation of the positive or negative pressure applied to the wound.

30 Figures 13 to 26 are cross-sectional views of conformable wound dressings, of the second aspect of the present invention for aspirating and/or irrigating wounds.

35 Figure 27a is a plan view and Figure 27b a cross-sectional view of a further conformable wound dressings of the second aspect of the present invention for aspirating and/or irrigating wounds.

Figures 28A and B are variants of a two-pump system with essentially identical, and identically numbered, components as in Figures 11.

5 However, they have alternative means for handling the aspirate flow to the aspirate collection vessel under negative or positive pressure to the wound in simultaneous aspiration and irrigation of the wound, including in Figure 27B a third device for moving fluid into a waste bag.

10 Figure 29 is a single-pump system essentially with the omission from the apparatus of Figures 11 of the second device for moving irrigant fluid into the wound dressing.

15 Referring to Figure 1, the apparatus (1) for aspirating, irrigating and/or cleansing wounds comprises
a conformable wound dressing (2), having
a backing layer (3) which is capable of forming a relatively fluid-tight seal or closure (4) over a wound (5) and
one inlet pipe (6) for connection to a fluid supply tube (7), which passes
20 through the wound-facing face of the backing layer (5) at (8), and
one outlet pipe (9) for connection to a fluid offtake tube (10), which passes through the wound-facing face at (11),
the points (8), (11) at which the inlet pipe and the outlet pipe passes through and/or under the wound-facing face forming a relatively fluid-tight
25 seal or closure over the wound;
the inlet pipe being connected via means for supply flow regulation, here a valve (14), by the fluid supply tube (7) to a fluid reservoir (12), and
the outlet pipe (9) being connected via means for aspirate flow regulation, here a valve (16) and a fluid offtake tube (10) to waste, e.g. to a collection
30 bag (not shown);
a device for moving fluid through the wound (17), here a diaphragm pump (18), e.g. preferably a small portable diaphragm pump, acting on the fluid aspiration tube (13) to apply a low negative pressure on the wound; and
the valve (14) in the fluid supply tube (7), the valve (16) in the fluid offtake tube (10), and the diaphragm pump (18), providing means for providing
35 simultaneous aspiration and irrigation of the wound (5),

such that fluid may be supplied to fill the flowpath from the fluid reservoir via the fluid supply tube (via the means for supply flow regulation) and moved by the device through the flow path.

- 5 The operation of the apparatus is as described hereinbefore.

Referring to Figure 2, the apparatus (21) is a variant two-pump system with essentially identical, and identically numbered, components as in Figure 1,
10 except that

there is no means for supply flow regulation in the fluid supply tube (7) from the fluid reservoir (12), and

there is

a first device for moving fluid through the wound (5), here a diaphragm
15 pump (18A), e.g. preferably a small portable diaphragm pump, acting on the fluid aspiration tube (13) downstream of and away from the wound dressing to apply a low negative pressure on the wound; with
means for negative pressure regulation, here a valve (16) connected to the vacuum tube (13) and a vacuum vessel (aspirate collection jar) (19); and
20 a second device for moving fluid through the wound (5), here a peristaltic pump (18B), e.g. preferably a small portable diaphragm pump, applied to the irrigant in the fluid supply tube (7) upstream of and towards the wound dressing,

the first device (18A) and second device (18B), and the valve (16) in the
25 vacuum tube (13), and the diaphragm pump (18), providing means for providing simultaneous aspiration and irrigation of the wound (5), such that fluid may be supplied to fill the flowpath from the fluid reservoir via the fluid supply tube (via the means for supply flow regulation) and moved by the devices through the flow path.

30

The operation of the apparatus is as described hereinbefore

Referring to Figures 3 to 6, each dressing (41) is in the form of a
35 conformable body defined by a microbe-impermeable film backing layer (72) with a uniform thickness of 25 micron.

It has a wound-facing face (43), which is capable of forming a relatively fluid-tight seal or closure over a wound.

5 The backing layer (72) extends in use on a wound over the skin around the wound.

10 On the proximal face of the backing layer (43) on the overlap (44), it bears an adhesive film (45), to attach it to the skin sufficiently to hold the wound dressing in place in a fluid-tight seal around the periphery of the wound-facing face (43) of the wound dressing.

15 There is one inlet pipe (76) for connection to a fluid supply tube (not shown), which passes through and/or under the wound-facing face (43), and one outlet pipe (77) for connection to a fluid offtake tube (not shown), which passes through and/or under the wound-facing face (43),

20 Referring to Figures 3a and 3b, one form of the dressing is provided with a wound filler (48) under a circular backing layer (42).

This comprises a generally frustoconical, toroidal conformable hollow body, defined by a membrane (49) which is filled with a fluid, here air or nitrogen, that urges it to the wound shape.

25 The filler (48) may be permanently attached to the backing layer with an adhesive film (not shown) or by heat-sealing.

30 The inlet pipe (46) and outlet pipe (47) are mounted centrally in the backing layer (42) above the central tunnel (50) of the toroidal hollow body (48) and each passes through the backing layer (42).

35 Each extends in pipes (51) and (52) respectively through the tunnel (50) of the toroidal hollow body (48) and then radially in diametrically opposite directions under the body (48).

This form of the dressing is a more suitable layout for deeper wounds.

Referring to Figures 4a and 4b, a more suitable form for shallower wounds is shown.

5 This comprises a circular backing layer (42) and a circular upwardly dished first membrane (61) with apertures (62) that is permanently attached to the backing layer (42) by heat-sealing to form a circular pouch (63).

10 The pouch (63) communicates with the inlet pipe (46) through a hole (64), and thus effectively forms an inlet pipe manifold that delivers the aspirating fluid directly to the wound when the dressing is in use.

15 An annular second membrane (65) with openings (66) is permanently attached to the backing layer (42) by heat-sealing to form an annular chamber (67) with the layer (42).

The chamber (67) communicates with the outlet pipe (47) through an orifice (68), and thus effectively forms an outlet pipe manifold that collects the fluid directly from the wound when the dressing is in use.

20 Referring to Figures 5a and 5b, a variant of the dressing of Figures 4a and 4b that is a more suitable form for deeper wounds is shown.

25 This comprises a circular backing layer (42) and a filler (69), in the form of an inverted frustoconical, solid integer, here a resilient elastomeric foam, formed of a thermoplastic, or preferably a cross-linked plastics foam.

It may be permanently attached to the backing layer (42), with an adhesive film (not shown) or by heat-sealing.

30 A circular upwardly dished sheet (70) lies under and conforms to, but is a separate structure, permanently unattached to, the backing layer (42) and the solid integer (69).

A circular upwardly dished first membrane (71) with apertures (72) is permanently attached to the sheet (70) by heat-sealing to form a circular pouch (73) with the sheet (70).

- 5 The pouch (73) communicates with the inlet pipe (46) through a hole (74), and thus effectively forms an inlet pipe manifold that delivers the aspirating fluid directly to the wound when the dressing is in use.

10 An annular second membrane (75) with openings (76) is permanently attached to the sheet (70) by heat-sealing to form an annular chamber (77) with the sheet (70).

15 The chamber (77) communicates with the outlet pipe (47) through an orifice (78), and thus effectively forms an outlet pipe manifold that collects the fluid directly from the wound when the dressing is in use.

20 Alternatively, where appropriate the dressing may be provided in a form in which the circular upwardly dished sheet (70) functions as the backing layer and the solid filler (69) sits on the sheet (70) as the backing layer, rather than under it. The filler (69) is held in place with an adhesive film or tape, instead of the backing layer (42).

25 Referring to Figures 6a and 6b, a dressing that is a more suitable form for deeper wounds is shown.

This comprises a circular backing layer (42) and a filler (79), in the form of an inverted generally hemispherical integer, permanently attached to the backing layer with an adhesive film (not shown) or by heat-sealing.

30 Here it is a resilient elastomeric foam or a hollow body filled with a fluid, here a gel that urges it to the wound shape.

The inlet pipe (46) and outlet pipe (47) are mounted peripherally in the backing layer (42).

35

A circular upwardly dished sheet (80) lies under and conforms to, but is a separate structure, permanently unattached to, the backing layer (42) and the filler (79).

5 A circular upwardly dished bilaminate membrane (81) has a closed channel (82) between its laminar components, with perforations (83) along its length on the outer surface (84) of the dish formed by the membrane (81) and
10 an opening (85) at the outer end of its spiral helix, through which the channel (82) communicates with the inlet pipe (46), and thus effectively forms an inlet pipe manifold that delivers the aspirating fluid directly to the wound when the dressing is in use.

15 The membrane (81) also has apertures (86) between and along the length of the turns of the channel (82).

The inner surface (87) of the dish formed by the membrane (81) is permanently attached at its innermost points (88) with an adhesive film (not shown) or by heat-sealing to the sheet (80). This defines a mating closed
20 spirohelical conduit (89).

At the outermost end of its spiral helix, the conduit (89) communicates through an opening (90) with the outlet pipe (47) and is thus effectively an outlet manifold to collect the fluid directly from the wound via the apertures
25 (86).

Referring to Figures 7a and 7b, one form of the dressing is provided with a circular backing layer (42).

30 A first (larger) inverted hemispherical membrane (92) is permanently attached centrally to the layer (42) by heat-sealing to form a hemispherical chamber (94) with the layer (42).

A second (smaller) concentric hemispherical membrane (93) within the first is permanently attached to the layer (42) by heat-sealing to form a hemispherical pouch (95).

- 5 The pouch (95) communicates with the inlet pipe (46) and is thus effectively an inlet manifold, from which pipes (97) radiate hemispherically and run to the wound bed to end in apertures (98). The pipes (97) deliver the aspirating fluid directly to the wound bed via the apertures (98).
- 10 The chamber (94) communicates with the outlet pipe (47) and is thus effectively an outlet manifold from which tubules (99) radiate hemispherically and run to the wound bed to end in openings (100). The tubules (99) collect the fluid directly from the wound via the openings (100).

15

Referring to Figures 8a to 8d, one form of the dressing is provided with a square backing layer (42) and

first tube (101) extending from the inlet pipe (46), and
second tube (102) extending from the outlet pipe (47)

- 20 at the points at which they pass through the backing layer, to run over the wound bed.

These pipes (101), (102) have a blind bore with orifices (103), (104) along the pipes (101), (102).

25

These pipes (101), (102) respectively form an inlet pipe or outlet pipe manifold that delivers the aspirating fluid directly to the wound bed or collects the fluid directly from the wound respectively via the orifices.

30

In Figures 8a and 8d, one layout of each of the pipes (101), (102) as inlet pipe and outlet pipe manifolds is a spiral.

- 35 In Figure 8b, the layout is a variant of that of Figures 8a and 8b, with the layout of the inlet manifold (101) being a full or partial torus, and the outlet manifold (102) being a radial pipe.

Referring to Figure 8c, there is shown another suitable layout in which the inlet manifold (101) and the outlet manifold (102) run alongside each other over the wound bed in a boustrophedic pattern, i.e. in the manner of ploughed furrows.

5

Referring to Figures 9a to 9d, there are shown other suitable layouts for deeper wounds, which are the same as shown in Figures 8a to 8d. The square backing layer (42) however has a wound filler (110) under, and may be permanently attached to, the backing layer (42), with an adhesive film (not shown) or by heat-sealing, which is an inverted hemispherical solid integer, here a resilient elastomeric foam, formed of a thermoplastic, preferably a cross-linked plastics foam.

10 Under the latter is a circular upwardly dished sheet (111) which conforms to, but is a separate structure, permanently unattached to, the solid filler (110). Through the sheet (111) pass the inlet pipe (46) and the outlet pipe (47), to run over the wound bed. These pipes (101), (102) again have a blind bore with orifices (103), (104) along the pipes (101), (102).

20

Alternatively (as in Figures 5a and 5b), where appropriate the dressing may be provided in a form in which the circular upwardly dished sheet (111) functions as the backing layer and the solid filler (110) sits on the sheet (42) as the backing layer, rather than under it. The filler (110) is held in place with an adhesive film or tape, instead of the backing layer (42).

25

In Figures 10a to 10c, inlet and outlet manifolds for the wound dressings for respectively delivering fluid to, and collecting fluid from, the wound, are formed by slots in and apertures through layers permanently attached to each other in a stack.

30

35

Thus, in Figure 10a there is shown an exploded isometric view of an inlet manifold and outlet manifold stack (120) of five square coterminous thermoplastic polymer layers, being first to fifth layers (121) to (125), each attached with an adhesive film (not shown) or by heat-sealing to the adjacent layer in the stack (120).

The topmost (first) layer (121) (which is the most distal in the dressing in use) is a blank square capping layer.

10 The next (second) layer (122), shown in Figure 10b out of the manifold stack (120), is a square layer, with an inlet manifold slot (126) through it. The slot (126) runs to one edge (127) of the layer (122) for connection to a mating end of a fluid inlet tube ((not shown), and spreads into four adjacent branches (128) in a parallel array with spaces therebetween.

15

The next (third) layer (123) is another square layer, with inlet manifold apertures (129) through the layer (123) in an array such that the apertures (129) are in register with the inlet manifold slot (126) through the second layer (122) (shown in Figure 10b).

20

The next (fourth) layer (124), shown in Figure 10c out of the manifold stack (120), is another square layer, with inlet manifold apertures (130) through the layer (124) in an array such that the apertures (130) are in register with the apertures (129) through the third layer (123).

25 It also has an outlet manifold slot (131) through it.

The slot (131) runs to one edge (132) of the layer (124) on the opposite side of the manifold stack (120) from the edge (127) of the layer (122), for connection to a mating end of a fluid outlet tube (not shown).

30

It spreads into three adjacent branches (133) in a parallel array in the spaces between the apertures (130) in the layer (124) and in register with the spaces between the apertures (129) in the layer (122).

35

The final (fifth) layer (125) is another square layer, with inlet manifold apertures (134) through the layer (125) in an array such that the apertures (134) are in register with the inlet manifold apertures (130) through the fourth layer (124) (in turn in register with the apertures (129) through the third layer (123). It also has outlet manifold apertures (135) in the layer (125) in an array such that the apertures (135) are in register with the outlet manifold slot (131) in the fourth layer (124).

It will be seen that, when the layers (121) to (125) are attached together to form the stack (120), the topmost (first) layer (121), the inlet manifold slot (126) through the second layer (122), and the third layer (123) cooperate to form an inlet manifold in the second layer (122), which is in use is connected to a mating end of a fluid inlet tube (not shown).

The inlet manifold slot (126) through the second layer (122), and the inlet manifold apertures (129), (130) and (134) through the layers (123), (124) and (125), all being mutually in register, cooperate to form inlet manifold conduits through the third to fifth layers (123), (124) and (125) between the inlet manifold in the second layer (122) and the proximal face (136) of the stack (120).

The third layer (121), the outlet manifold slot (131) through the fourth layer (124), and the fifth layer (125) cooperate to form an outlet manifold in the fourth layer (124), which is in use is connected to a mating end of a fluid outlet tube (not shown).

The outlet manifold slot (131) through the fourth layer (124), and the outlet manifold apertures (135) through the fifth layer (125), being mutually in register, cooperate to form outlet manifold conduits through the fifth layer (125) between the outlet manifold in the fourth layer (124) and the proximal face (136) of the stack (120).

Referring to Figure 11A, the apparatus (21) is a variant two-pump system with essentially identical, and identically numbered, components as in Figure 2.

Thus, there is

a means for supply flow regulation, here a valve (14) in the fluid supply tube (7) from the fluid reservoir (12), and

5 a first device for moving fluid through the wound (5), here a fixed-speed diaphragm pump (18A), e.g. preferably a small portable diaphragm pump, acting not on the fluid aspiration tube (13), but on an air aspiration tube (113) downstream of and away from an aspirate collection vessel (19) to apply a low negative pressure on the wound through the aspirate collection vessel (19); with

10 a second device for moving fluid through the wound (5), here a fixed-speed peristaltic pump (18B), e.g. preferably a small portable peristaltic pump, applied to the irrigant in the fluid supply tube (7) upstream of and towards the wound dressing,

15 the first device (18A) and second device (18B), and the valve (14) in the fluid supply tube (7), providing means for providing simultaneous aspiration and irrigation of the wound (5), such that fluid may be supplied to fill the flowpath from the fluid reservoir via the fluid supply tube (via the means for supply flow regulation) and moved by the devices through the flow path.

20 There is no means for aspirate flow regulation, e.g. a valve connected to the fluid offtake tube (10).

Since first device (18A) and second device (18B) are fixed-speed, the valve (14) in the fluid supply tube (7) provides the sole means for varying the irrigant flow rate and the low negative pressure on the wound.

25 The following extra features are present :

30 The second device, the fixed-speed peristaltic pump (18B), is provided with means for avoiding over-pressure, in the form of a bypass loop with a non-return valve (115). The loop runs from the fluid supply tube (7) downstream of the pump (18B) to a point in the fluid supply tube (7) upstream of the pump (18B).

A pressure monitor (116) connected to the fluid offtake tube (10) has a feedback connection to a bleed regulator, here a motorised rotary valve (117) on a bleed tube (118) running to and centrally penetrating the top of the aspirate collection vessel (19). This provides means for holding the low
5 negative pressure on the wound at a steady level.

A filter (119) downstream of the aspirate collection vessel (19) prevents passage of gas- (often air-) borne particulates, including liquids and micro-organisms, from the irrigant and/or exudate that passes into the aspirate
10 collection vessel (19) into the first device (18A), whilst allowing the carrier gas to pass through the air aspiration tube (113) downstream of it to the first device (18A). The operation of the apparatus is as described hereinbefore

15 Referring to Figure 11B, this shows an alternative layout of the essentially identical, and identically numbered, components in Figure 11A downstream of point A in Figure 11A. The bleed tube (118) runs to the air aspiration tube (113) downstream of the filter (119), rather than into the aspirate
20 collection vessel (19). This provides means for holding the low negative pressure on the wound at a steady level. The operation of the apparatus is as described hereinbefore

25 Referring to Figure 11C, this shows an alternative layout of the essentially identical, and identically numbered, components in Figure 11A upstream of point B in Figure 11A. The second device (18B) is a variable-speed pump, and the valve (14) in the fluid supply tube (7) is omitted. The second device (18B) is the sole means for varying the irrigant flow rate and the low
30 negative pressure on the wound. The operation of the apparatus is as described hereinbefore

35 Referring to Figure 11D, this shows an alternative layout of the essentially identical, and identically numbered, components in Figure 11A downstream of point B in Figure 11A.

The pressure monitor (116) is connected to a monitor offtake tube (120) and has a feedback connection to the bleed regulator, motorised rotary valve (117) on a bleed tube (118) running to the monitor offtake tube (120). This provides means for holding the low negative pressure on the wound at a steady level. The operation of the apparatus is as described hereinbefore

Referring to Figure 12A, this shows another alternative layout of the essentially identical, and identically numbered, components in Figure 11A downstream of point B in Figure 11A.

The pressure monitor (116) is connected to a monitor offtake tube (120) and has a feedback connection to a means for aspirate flow regulation, here a motorised valve (16) in the air aspiration tube (113) downstream of the filter (119).

This provides means for aspirate flow regulation and for holding the low negative pressure on the wound at a steady level. The operation of the apparatus is as described hereinbefore

Referring to Figure 12B, this shows another alternative layout of the essentially identical, and identically numbered, components in Figure 12A downstream of point B in Figure 11A. The pressure monitor (116) is connected to a monitor offtake tube (120) and has a feedback connection to a means for aspirate flow regulation, here a motorised valve (16), in the fluid offtake tube (10) upstream of the aspirate collection vessel (19).

This provides means for aspirate flow regulation and for holding the low negative pressure on the wound at a steady level. The operation of the apparatus is as described hereinbefore

Referring to Figure 12C, this shows another alternative layout of the essentially identical, and identically numbered, components in Figure 12A downstream of point B in Figure 11A.

The pressure monitor (116) is connected to a monitor offtake tube (120) and has a feedback connection to a variable-speed first device (18A), here a variable-speed pump, downstream of the filter (119), and the valve (16) in the fluid offtake tube (10) is omitted.

5

This provides means for aspirate flow regulation and for holding the low negative pressure on the wound at a steady level. The operation of the apparatus is as described hereinbefore.

10

Referring to Figures 13 to 15, these forms of the dressing are provided with a wound filler (348) under a circular backing layer (342).

15 This comprises respectively a generally downwardly domed or toroidal, or oblately spheroidal conformable hollow body, defined by a membrane (349) which is filled with a fluid, here air or nitrogen, that urges it to the wound shape.

20 The filler (348) is permanently attached to the backing layer via a boss (351), which is e.g. heat-sealed to the backing layer (342).

25 An inflation inlet pipe (350), inlet pipe (346) and outlet pipe (347) are mounted centrally in the boss (351) in the backing layer (342) above the hollow body (348). The inflation inlet pipe (350) communicates with the interior of the hollow body (348), to permit inflation of the body (348). The inlet pipe (346) extends in a pipe (352) effectively through the hollow body (348). The outlet pipe (347) extends radially immediately under the backing layer (342).

30 In Figure 13, the pipe (352) communicates with an inlet manifold (353), formed by a membrane (361) with apertures (362) that is permanently attached to the filler (348) by heat-sealing.

35 It is filled with foam (363) formed of a suitable material, e.g. a resilient thermoplastic. Preferred materials include reticulated filtration polyurethane foams with small apertures or pores.

In Figure 14, the outlet pipe (347) communicates with a layer of foam (364) formed of a suitable material, e.g. a resilient thermoplastic. Again, preferred materials include reticulated filtration polyurethane foams with small apertures or pores.

5

In all of Figures 13, 14 and 15, in use, the pipe (346) ends in one or more openings that deliver the irrigant fluid directly from the wound bed over an extended area.

10 Similarly, the outlet pipe (347) effectively collects the fluid radially from the wound periphery when the dressing is in use.

Referring to Figure 16, the dressing is also provided with a wound filler (348) under a circular backing layer (342).

15

This also comprises a generally toroidal conformable hollow body, defined by a membrane (349) which is filled with a fluid, here air or nitrogen, that urges it to the wound shape.

20

The filler (348) may be permanently attached to the backing layer (342) via a first boss (351) and a layer of foam (364) formed of a suitable material, e.g. a resilient thermoplastic. Again, preferred materials include reticulated filtration polyurethane foams with small apertures or pores.

25

The first boss (351) and foam layer (364) are respectively heat-sealed to the backing layer (342) and the boss (351).

An inflation inlet pipe (350), inlet pipe (346) and outlet pipe (347) are mounted centrally in the first boss (351) in the backing layer (342) above the toroidal hollow body (348).

30

The inflation inlet pipe (350), inlet pipe (346) and outlet pipe (347) respectively each extend in a pipe (353), (354) and (355) through a central tunnel (356) in the hollow body (348) to a second boss (357) attached to the toroidal hollow body (348).

35

The pipe (353) communicates with the interior of the hollow body (348), to permit inflation of the body (348).

5 The pipe (354) extends radially through the second boss (357) to communicate with an inlet manifold (352), formed by a membrane (361).

10 This is permanently attached to the filler (348) by heat-sealing in the form of a reticulated honeycomb with openings (362) that deliver the irrigant fluid directly to the wound bed over an extended area.

The pipe (355) collects the fluid flowing radially from the wound centre when the dressing is in use.

15 This form of the dressing is a more suitable layout for deeper wounds

In Figure 17, the dressing is similar to that of Figure 16, except that the toroidal conformable hollow body, defined by a membrane (349), is filled with a fluid, here a solid particulates, such as plastics crumbs or beads, rather than a gas, such as air or an inert gas, such as nitrogen or argon.
20 The inflation inlet pipe (350) and pipe (353) are omitted from the central tunnel (356).

25 Examples of contents for the body (348) also include gels, such as silicone gels or preferably cellulosic gels, for example hydrophilic cross-linked cellulosic gels, such as Intrasite™ cross-linked materials. Examples also include aerosol foams, and set aerosol foams, e.g. CaviCare™ foam.

30 Referring to Figures 18 and 19, another form for deeper wounds is shown. This comprises a circular backing layer (342) and a lobed chamber (363) in the form of a deeply indented disc much like a multiple Maltese cross or a stylised rose.

This is defined by an upper impervious membrane (361) and a lower porous film (362) with apertures (364) that deliver the irrigant fluid directly from the wound bed over an extended area.

- 5 A number of configurations of the chamber (363) are shown, all of which are able to conform well to the wound bed by the arms closing in and possibly overlapping in insertion into the wound.

10 In a particular design of the chamber (363), shown lowermost, one of the arms extended and provided with an inlet port at the end of the extended arm. This provides the opportunity for coupling and decoupling the irrigant supply remote from the dressing and the wound in use.

15 An inlet pipe (346) and outlet pipe (347) are mounted centrally in a boss (351) in the backing layer (342) above the chamber (363). The inlet pipe (346) is permanently attached to, and communicate with the interior of, the chamber (363), which thus effectively forms an inlet manifold. The space above the chamber (363) is filled with a loose gauze packing (364).

20 In Figure 18, the outlet pipe (347) collects the fluid from the interior of the dressing from just under the wound-facing face (343) of the backing layer (342).

25 A variant of the dressing of Figure 18 is shown in Figure 19. The outlet pipe (347) is mounted to open at the lowest point of the space above the chamber (363) into a piece of foam (374).

30 In Figure 20, the dressing is similar to that of Figure 13, except that the inlet pipe (352) communicates with an inlet manifold (353).

The latter is formed by a membrane (361) with apertures (362), over the upper surface of the generally downwardly domed wound hollow filler (348), rather than through it.

In Figure 21, the dressing is similar to that of Figure 14, with the addition of an inlet manifold (353), formed by a membrane (361) with apertures (362), over the lower surface of the generally downwardly domed annular wound hollow filler.

5

In Figure 22, the generally downwardly domed annular wound hollow filler is omitted.

10

Referring to Figure 23, another form for deeper wounds is shown. An inlet pipe (346) and outlet pipe (347) are mounted centrally in a boss (351) in the backing layer (342) above a sealed-off foam filler (348).

15 The inlet pipe (346) is permanently attached to and passes through the filler (348) to the wound bed. The outlet pipe (347) is attached to and communicates with the interior of, a chamber (363) defined by a porous foam attached to the upper periphery of the filler (348). The chamber (363) thus effectively forms an outlet manifold.

20

In Figure 24, the foam filler (348) is only partially sealed-off. The inlet pipe (346) is permanently attached to and passes through the filler (348) to the wound bed. The outlet pipe (347) is attached to and communicates with the interior of the foam of the filler (348). Fluid passes into an annular gap (349) near the upper periphery of the filler (348) into the foam, which thus effectively forms an outlet manifold.

25

30 Figures 25 and 26 show dressings in which the inlet pipe (346) and outlet pipe (347) pass through the backing layer (342).

In Figure 25, they communicate with the interior of a porous bag filler (348) defined by a porous film (369) and filled with elastically resilient plastics bead or crumb.

35

In Figure 26, they communicate with the wound space just below a foam filler (348). The foam (348) may CaviCare™ foam, injected and formed in situ around the pipes (346) and (347).

5

Referring to Figure 27, another form for deeper wounds is shown. This comprises a circular, or more usually square or rectangular backing layer (342) and a chamber (363) in the form of a deeply indented disc much like a multiple Maltese cross or a stylised rose.

10

This is defined by an upper impervious membrane (361) and a lower porous film (362) with apertures (364) that deliver the irrigant fluid directly to the wound bed over an extended area, and thus effectively forms an inlet manifold. Three configurations of the chamber (363) are shown in Figure 27b, all of which are able to conform well to the wound bed by the arms closing in and possibly overlapping in insertion into the wound.

15

The space above the chamber (363) is filled with a wound filler (348) under the backing layer (342). This comprises an oblately spheroidal conformable hollow body, defined by a membrane (349) that is filled with a fluid, here air or nitrogen, that urges it to the wound shape.

20

A moulded hat-shaped boss (351) is mounted centrally on the upper impervious membrane (361) of the chamber (363). It has three internal channels, conduits or passages through it (not shown), each with entry and exit apertures. The filler (348) is attached to the membrane (361) of the chamber (363) by adhesive, heat welding or a mechanical fixator, such as a cooperating pin and socket.

25

An inflation inlet pipe (350), inlet pipe (346) and outlet pipe (347) pass under the edge of the proximal face of the backing layer (342) of the dressing.

30

It extend radially immediately under the filler (348) and over the membrane (361) of the chamber (363) to each mate with an entry aperture in the boss (351).

35

An exit to the internal channel, conduit or passage through it that receives the inflation inlet pipe (350) communicates with the interior of the hollow filler (348), to permit inflation.

5

An exit to the internal channel, conduit or passage that receives the inlet pipe (346) communicates with the interior of the chamber (363) to deliver the irrigant fluid via the chamber (363) to the wound bed over an extended area.

10

Similarly, an exit to the internal channel, conduit or passage that receives the outlet pipe (347) communicates with the space above the chamber (363) and under the wound filler (348), and collects flow of irrigant and/or wound exudate radially from the wound periphery.

15

Referring to Figure 28A, this shows another alternative layout of the essentially identical, and identically numbered, components in Figure 12C downstream of point B in Figure 12A, and alternative means for handling the aspirate flow to the aspirate collection vessel under negative or positive pressure to the wound. The pressure monitor (116) is connected to a monitor offtake tube (120) and has a feedback connection to a variable-speed first device (18A), here a variable-speed pump, upstream of the aspirate collection vessel (19), and the filter (119) and the air aspiration tube (113) are omitted. This provides means for aspirate flow regulation and for holding the low negative pressure on the wound at a steady level. The operation of the apparatus is as described hereinbefore.

20

25

Referring to Figure 28B, this shows another alternative layout of the essentially identical, and identically numbered, components in Figure 12C downstream of point B in Figure 11A, and alternative means for handling the aspirate flow to the aspirate collection vessel under negative or positive pressure to the wound. The pressure monitor (116) is omitted, as is the feedback connection to a variable-speed first device (18A), here a variable-speed pump, downstream of the aspirate collection vessel (19) and the filter (119).

30

35

A third device (18C), here a fixed-speed pump, provides means for moving fluid from the aspirate collection vessel (19) into a waste bag (12C). The operation of the apparatus is as described hereinbefore.

5

Referring to Figure 29, this shows an alternative layout of the essentially identical, and identically numbered, components in Figure 11A upstream of point A in Figure 11A.

10 It is a single-pump system essentially with the omission from the apparatus of Figure 11A of the second device for moving irrigant fluid into the wound dressing. The operation of the apparatus is as described hereinbefore.

15 The use of the apparatus of the present invention will now be described by way of example only in the following Example:

Example 1 - Removal of wound proteins and derivatives with a two-pump apparatus.

20

In this example, a gelatine sheet laid in a cavity wound model represents wound proteins and derivatives to be removed by the two-pump apparatus. The dressing is essentially identical with that in Figure 18, i.e. it comprises a circular backing layer and a lobed chamber in the form of a deeply
25 indented disc much like a multiple Maltese cross or a stylised rose, defined by an upper impervious membrane and a lower porous film with apertures that deliver the irrigant fluid directly from the wound bed over an extended area.

30 A two-pump system was set up essentially as in Figure 2, with an irrigant dispensing bottle – 1000ml Schott Duran, connected to a peristaltic pump (Masterflex) for irrigant delivery, and associated power supply and supply tube,
a diaphragm vacuum pump (Schwarz) for aspiration, and associated power
35 supply and offtake tube, connected to a vacuum vessel (aspirate collection jar) – Nalgene 150ml polystyrene

each pump being connected to

a dressing consisting of the following elements:

- 5 i) a wound contacting element, comprising a lobed bag with low porosity 'leaky' membrane wound contact layer on the lower surface, impermeable film on the top, and a foam spacer between the two layers to allow free flow of irrigant solution.
- ii) a space filling element, comprising a reticulated, open-cell foam (black reticulated foam, Foam Techniques) 30mm thick, 60mm diameter
- 10 iii) an occlusive adhesive coated polyurethane backing layer top film (Smith & Nephew Medical) with acrylic pressure sensitive adhesive
- iv) two tubes passing under the occlusive top film, and sealed to prevent leakage of gas or liquid:
 - 15 a. one tube centrally penetrating the top film of the wound-contacting element to deliver irrigant into the chamber formed by this film and the porous element;
 - b. the other tube of approximately equal length to remove aspirate with the opening positioned just above the top film of the wound contacting element.

20 Preparation of gelatine sheet:

A 20% aqueous solution of gelatine was prepared by weighing gelatine into a glass jar and making it up to the required weight with deionised water. The jar was placed in an oven (Heraeus), at set temperature 85°C. After 60 minutes the jar was removed from the oven and shaken, to encourage mixing. Petri dishes were partially filled with 10g quantities of the gelatine solution and placed in a fridge (LEC, set temperature: 4°C) to set for at least 1 hour. Final thickness of the gelatine slab was ~5mm. Petri dishes containing the gelatine slabs were removed from the fridge at least 2 hours before use.

30 Preparation of test equipment and materials

Irrigant solution (deionised water) and the Perspex wound model were pre-conditioned in an oven (Gallenkamp) at set temperature 37°C, for at least 4 hours before use.

35 For each test, a freshly prepared gelatine slab was removed from a Petri dish and weighed.

The Perspex wound model was then removed from the oven and the gelatine slab placed at the bottom of the cavity. Application of the dressing to the wound model was as follows:

- 5 - the wound contacting element was carefully placed over the gelatine slab
- the foam filler was placed on top of this with the irrigant and aspirate tubes running centrally to the top of the cavity (the foam filler was slit to the centre to facilitate this).
- 10 - the side entry port, pre-threaded onto the tubes, was adhesively bonded to the upper surface of the wound model block using an acrylic pressure sensitive adhesive
- the top adhesive coated film was applied over all of the elements and pressed down to give a seal on all sides, and especially around the tube entry/exit point

15

Application of the dressing to the wound model was the same for all tests performed. All tubing used was the same for each experiment (e.g. material, diameter, length).

Simultaneous Irrigation & Aspiration

20 A schematic diagram of the system used in the experiment is shown below. For the experiment most of the apparatus (not including the pumps, power supply, and connecting tubing to and from the pumps) was placed in an oven (Gallenkamp, set temperature: 37°C), on the same shelf.

25 Before starting the irrigation pump a vacuum was drawn on the system to check that the dressing and tube connections were substantially airtight (the pumping system was controlled to give a pressure at the vacuum vessel of approximately -75mmHg before opening the system up to include the dressing).

30 Once system integrity had been confirmed, the irrigation pump was started (nominal flow rate: 50ml/hr), i.e. both pumps running together. Timing of the experiment was started when the advancing water front within the irrigant tube was observed to have reached the top of the dressing.

35 After 60 minutes, the irrigation pump was stopped, shortly followed by the vacuum (aspiration) pump.

Aspirate liquid collected in the vacuum jar was decanted into a glass jar. The vacuum jar was rinsed with ~100ml of deionised water and this added to the same glass jar.

- 5 The aspirate solution was placed in an oven (Heraeus, set temperature: 130°C) and dried to constant weight.

Sequential Irrigation & Aspiration

The experimental set up was as for the simultaneous irrigation/aspiration experiment.

10

Before starting the experiment a vacuum was pulled on the system to check that the dressing and tube connections were substantially airtight. The pumping system was controlled to give a pressure at the vacuum vessel of approximately -75mmHg before opening the system up to include the dressing. Once system integrity had been confirmed, the irrigation pump

15

was started (nominal rate: 186ml/hr) and run until the advancing water front in the irrigant tube was observed to have reached the top of the dressing. The pump was temporarily stopped at this point whilst the vacuum line was sealed (using a tube clamp) and the vacuum pump stopped.

20

Timing of the experiment was from the point the irrigation pump was restarted. The pump was run until 50ml of irrigant had entered the wound model (just over 16 minutes at the rate of 186ml/hr). At this point the irrigant pump was stopped.

25

It was observed that during the filling phase of sequential filling and flushing, air trapped in the model wound cavity caused the top film of the dressing to inflate substantially, to a point approaching failure.

30

After a further ~44 minutes (60 minutes from the start of the experiment) the vacuum pump was started and the tube clamp on the aspirate line removed. The wound model was aspirated for 5 minutes. Towards the end of this period a small leak was introduced into the top film of the dressing to maximise the amount of fluid drawn from the wound model (it was observed

35

that as the pressure differential between the wound model cavity and the vacuum jar reduced to zero, the flow of aspirate also tended to slow.

Introducing a small leak re-established the pressure differential and the flow of aspirate out of the cavity).

Results

5

Simultaneous Irrigation & Aspiration			
Reference number	Aspirate recovered (g)	Recovery of gelatine (%)	Concentration of gelatine in aspirated fluid (%w/w)
1	48.81	79.33	3.27
2	45.64	72.30	3.18
3	48.84	68.05	2.76
Mean	47.76	73.22	3.07

Sequential Irrigation & Aspiration Cycle			
Reference number	Aspirate recovered (g)	Recovery of gelatine (%)	Concentration of gelatine in aspirated fluid (%w/w)
1	32.08	19.59	1.23
2	34.09	18.35	1.07
3	33.90	10.77	0.64
Mean	33.36	16.24	0.98

Conclusions

- 10 Simultaneously irrigating and aspirating the wound model removed more of the gelatine placed at the base of the wound model cavity than sequentially filling and emptying the cavity, even though the amount of liquid entering the wound and the duration of the experiment were the same in both cases.
- 15 Simultaneously irrigating and aspirating also removed more fluid from the model wound.

Example 2. The combination of simultaneous fluid flow (irrigation) and aspiration (under reduced pressure) on wound bed fibroblasts compared with the exposure of wound bed fibroblasts to repeated fill-empty cycles of fluid flow and aspiration.

5 An apparatus of the present invention was constructed essentially as in Figure 30, which is an apparatus where an irrigant is delivered continually to the wound bed and the resultant wound exudate/fluid mixture is at the same time continually aspirated from the wound. Alternative systems are known where the wound is subjected to repeated iteration of a cycle of fluid
10 delivery followed by a period of aspiration under reduced pressure.

The apparatus comprised a surrogate wound chamber (Minucells perfusion chamber) in which normal diploid human fibroblasts were cultured on 13 mm diameter (Thermanox polymer) cover slips retained in a two part
15 support (Minucells Minusheets). Tissues present in the healing wound that must survive and proliferate were represented by the cells within the chamber. Nutrient medium (DMEM with 10% FCS with 1% Buffer All) to simulate an irrigant fluid/wound exudate mixture, was pumped from a reservoir into the lower aspect of the chamber where it bathed the
20 fibroblasts and was removed from the upper aspect of the chamber and returned to a second reservoir. The wound chamber was maintained at less than atmospheric pressure by means of a vacuum pump in line with the circuit.

25 The pumps for the circuit were peristaltic pumps acting on silicone (or equivalent) elastic tubing. The circuit was exposed to a vacuum of no more than 10% atmospheric pressure, 950 mbar and atmospheric pressure varied up to a maximum value of 1044 mbar.. The internal diameter of the tubing was 1.0 mm. A total volume for the circuit including the chamber
30 and the reservoir of between 50 and 220 ml was used. The flow rates used were at a number of values between 0.1 ml min^{-1} and $2.0 \text{ ml}^{-1} \text{ min}^{-1}$.

An experiment was conducted that simulated conditions that are not
35 uncommon for healing wounds whereby a fluid was delivered to the wound bed and the application of a vacuum was used to remove the mixture of fluid and exudate to a waste reservoir.

An air bleed fluid control valve was additionally positioned in the circuit so that on opening the air bleed occurred for a time and closed the fluid flow, the simulated irrigant fluid/wound exudate mixture was evacuated from the chamber and the fibroblasts were maintained under a negative pressure
5 relative to the atmosphere. This represents an empty / fill system.

Results and Conclusions

The following results were obtained for a circuit comprising a wound
10 chamber as above containing a total volume of nutrient media (154 ml) pumped at a flow rate of 0.2 ml min^{-1} and where vacuum was set at 950 mbar and where atmospheric pressure varied up to a maximum value of 1044 mbar. The wound chamber and media were held at 37°C for 25 hours. In one set of wound chambers continuous flow was maintained. In
15 a second set of chambers 6 cycles of empty/ fill were performed with each fill or empty phase lasting 1 hour.

In controls where empty/fill system with 6 x cycles of 1 hour empty/ 1 hour
20 fill over a total of 25 hours, the survival and growth of the fibroblasts is inhibited.

However, when the nutrient medium flow in the first circuit is delivered
continually to the Minucells chamber and the resultant nutrient medium is at the same time continually aspirated from the Minucells chamber under
25 vacuum was set at 950 mbar and where atmospheric pressure varied up to a maximum value of 1044 mbar, the fibroblasts survive and proliferate to a greater extent during a 25 hour period than the control empty/fill circuits

Conditions	Mean relative level of cell activity* after 25 hours.
Baseline cell activity prior to introduction to wound chamber	100%
Fill empty 6 cycles	93%
Continuous flow	143%

*Cell activity measured with a WST (Tetrazolium based mitochondrial dehydrogenase activity assay). Data normalised to fibroblasts seeded onto coverslips with normal nutrient media baseline activity

- 5 The combination of continuous fluid flow at 0.2 ml min^{-1} and waste fluid removal under vacuum of no more than 10% atmospheric pressure, 950 mbar and atmospheric pressure varied up to a maximum value of 1044 mbar, enhances the cell response necessary for wound healing more than the fill empty fill pattern under vacuum.

10

Claims:

1. an apparatus for aspirating, irrigating and/or cleansing wounds, comprising
- 5 a) a fluid flow path, comprising a conformable wound dressing, having a backing layer which is capable of forming a relatively fluid-tight seal or closure over a wound and at least one inlet pipe for connection to a fluid supply tube, which passes through and/or under the wound-facing face, and
- 10 and at least one outlet pipe for connection to a fluid offtake tube, which passes through and/or under the wound-facing face, the point at which the or each inlet pipe and the or each outlet pipe passes through and/or under the wound-facing face forming a relatively fluid-tight seal or closure over the wound;
- 15 b) a fluid reservoir connected by a fluid supply tube to an inlet pipe via optional means for supply flow regulation;
- c) at least one device for moving fluid through the wound dressing; characterised in that it comprises
- 20 d) means for providing simultaneous aspiration and irrigation of the wound,
- such that fluid may be supplied to fill the flowpath from the fluid reservoir via the fluid supply tube (optionally via means for supply flow regulation) while fluid is aspirated by a device through the fluid offtake tube (optionally or as necessary via means for aspirate flow regulation).

25

2. An apparatus according to claim 1, characterised in that the means for providing simultaneous aspiration and irrigation of the wound comprises a first device for moving fluid through the wound applied to fluid downstream of and away from the wound dressing, in combination with
5 at least one of
a second device for moving fluid through the wound applied to the irrigant in the fluid supply tube upstream of and towards the wound dressing;
means for aspirate flow regulation, connected to a fluid offtake tube,
10 and
means for supply flow regulation, connected to a fluid supply tube;
3. An apparatus according to claim 1, characterised in that the aspirate in the fluid offtake tube downstream of the wound dressing is aspirated
15 into a collection vessel, and the first device acts on fluid from the collection vessel.
4. An apparatus according to claim 2, characterised in that the first device and/or second device is a fixed throughput device, and the means for providing simultaneous aspiration and irrigation of the wound also
20 comprises at least one of
means for supply flow regulation, connected to a fluid supply tube, and
means for aspirate flow regulation, connected to a fluid offtake tube.
- 25 5. An apparatus according to claim 2, characterised in that the first device and/or second device is a variable-throughput device, and the means for providing simultaneous aspiration and irrigation of the wound does not comprise other means for aspirate flow regulation, connected to a fluid offtake tube and/or other means for supply flow regulation,
30 connected to a fluid supply tube.
6. An apparatus according to claim 1, characterised in that the means for providing simultaneous aspiration and irrigation of the wound comprises
35 means for providing simultaneous aspiration and irrigation of the wound comprises

5 a first device for moving fluid through the wound applied to fluid downstream of and away from the wound dressing, and a second device for moving fluid through the wound applied to the irrigant in the fluid supply tube upstream of and towards the wound dressing.

10 7. An apparatus according to claim 8, characterised in that the first device and/or second device is a fixed throughput device, and the means for providing simultaneous aspiration and irrigation of the wound also comprises at least one of means for supply flow regulation, connected to a fluid supply tube, and means for aspirate flow regulation, connected to a fluid offtake tube.

15 8. An apparatus according to claim 8, characterised in that the first device and/or second device is a variable-throughput device, and the means for providing simultaneous aspiration and irrigation of the wound does not comprise other means for aspirate flow regulation, connected to a fluid offtake tube and/or other means for supply flow regulation, connected to a fluid supply tube.

20 9. A conformable wound dressing for use in an apparatus according to claim 1, characterised in that it comprises a backing layer with a wound-facing face which is capable of forming a relatively fluid-tight seal or closure over a wound and has
25 at least one inlet pipe for connection to a fluid supply tube, which passes through and/or under the wound-facing face, and at least one outlet pipe for connection to a fluid offtake tube, which passes through and/or under the wound-facing face,
30 the point at which the or each inlet pipe and the or each outlet pipe passes through and/or under the wound-facing face forming a relatively fluid-tight seal or closure over the wound.

10. A method of treating wounds to promote wound healing using the apparatus according to claim 1.

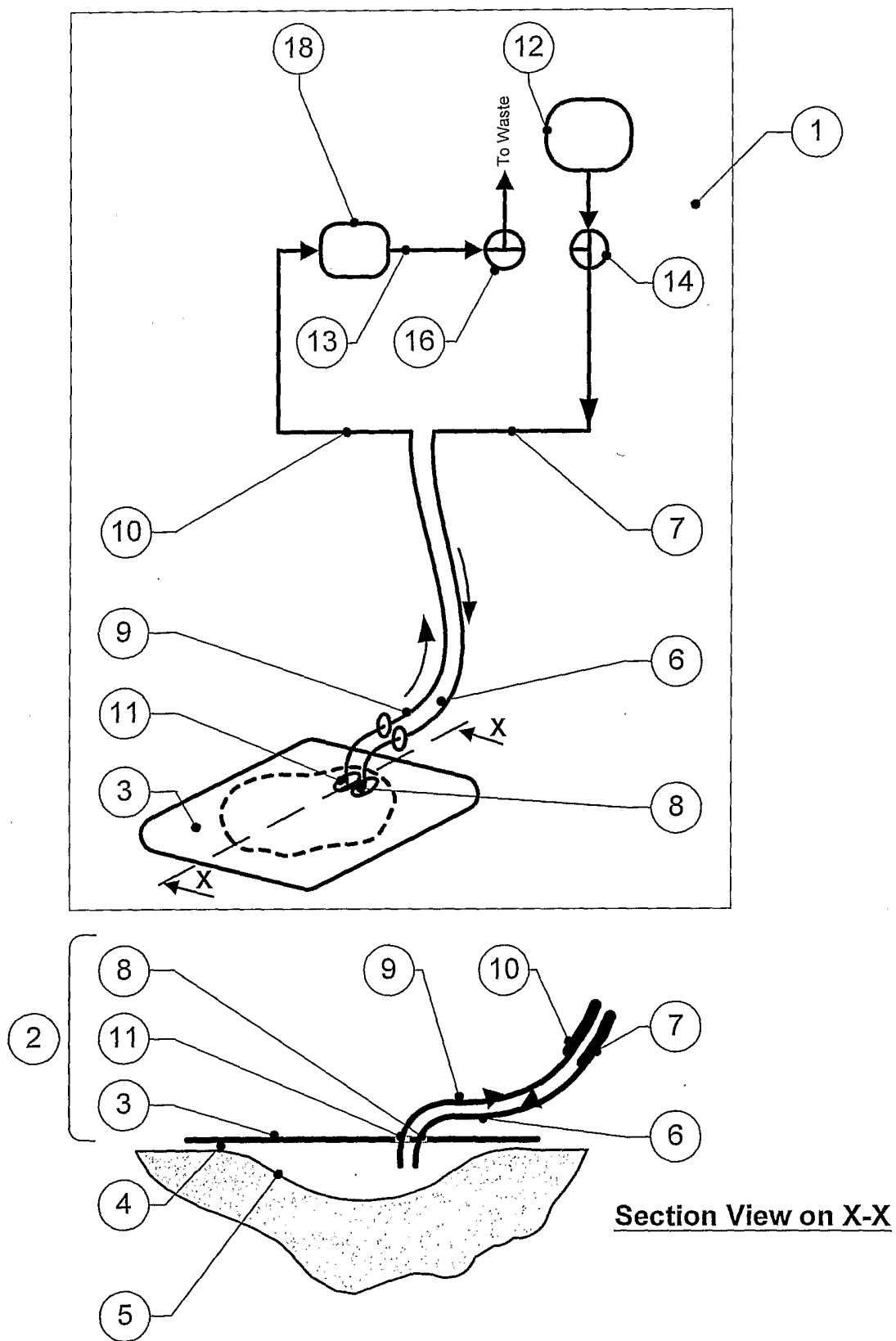

Figure 1

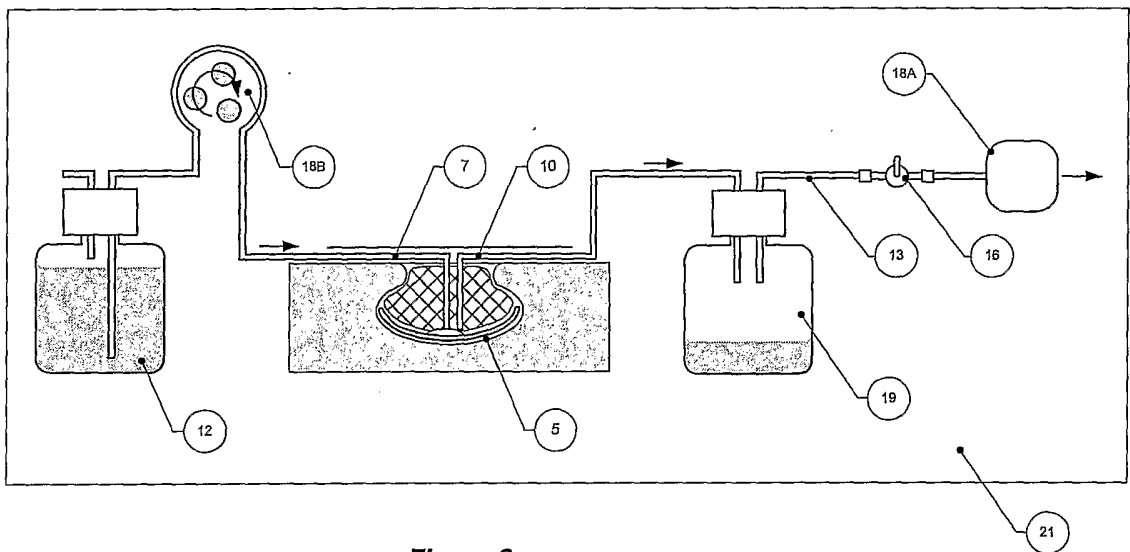

Figure 2

5

10

15

20

25

30

5

PAGE INTENTIONALLY LEFT BLANK

10

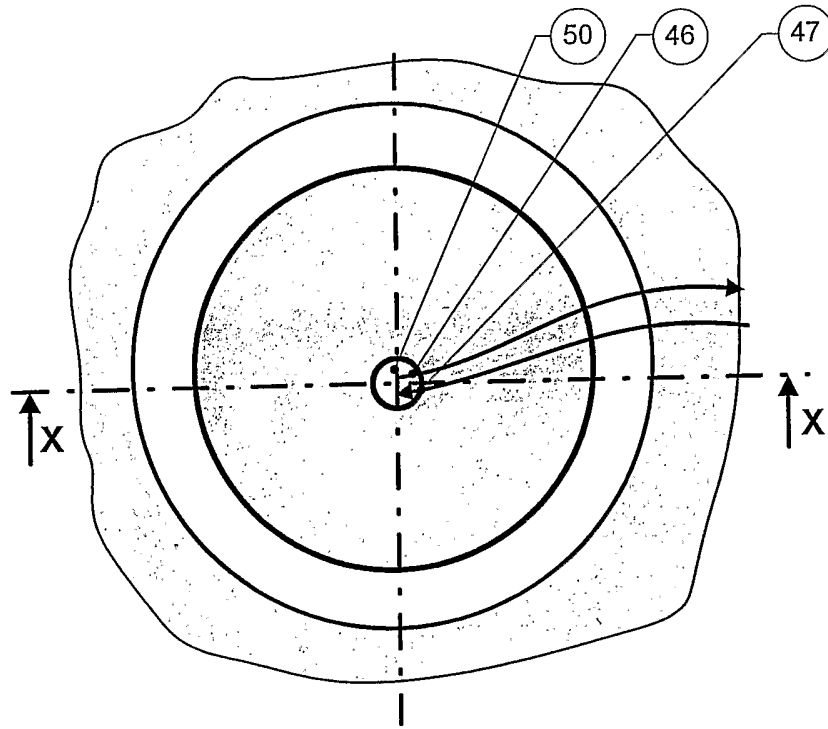

Figure 3a

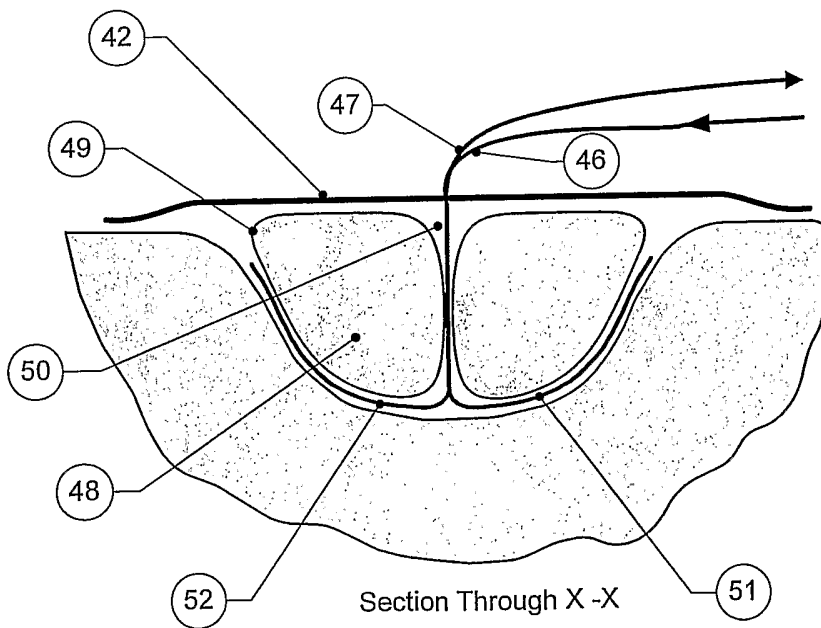

Figure 3b

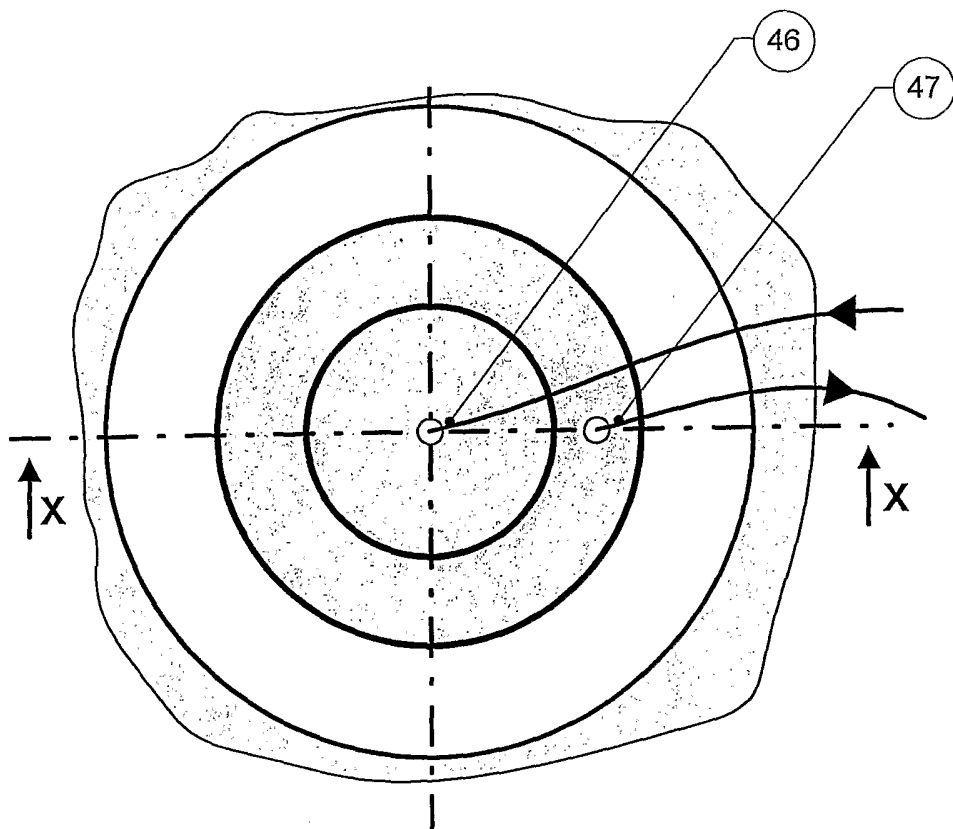

Figure 4a

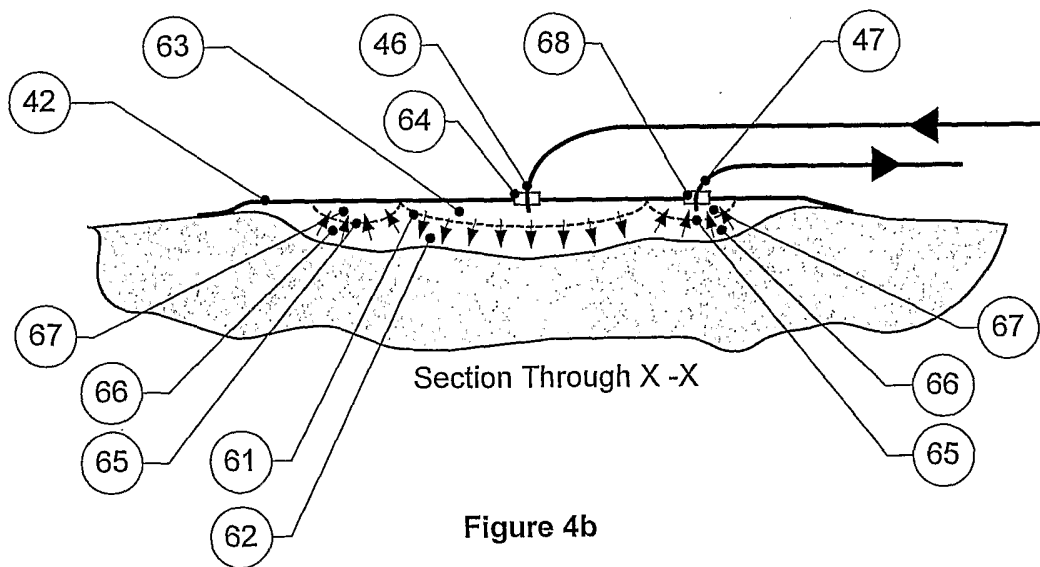

Figure 4b

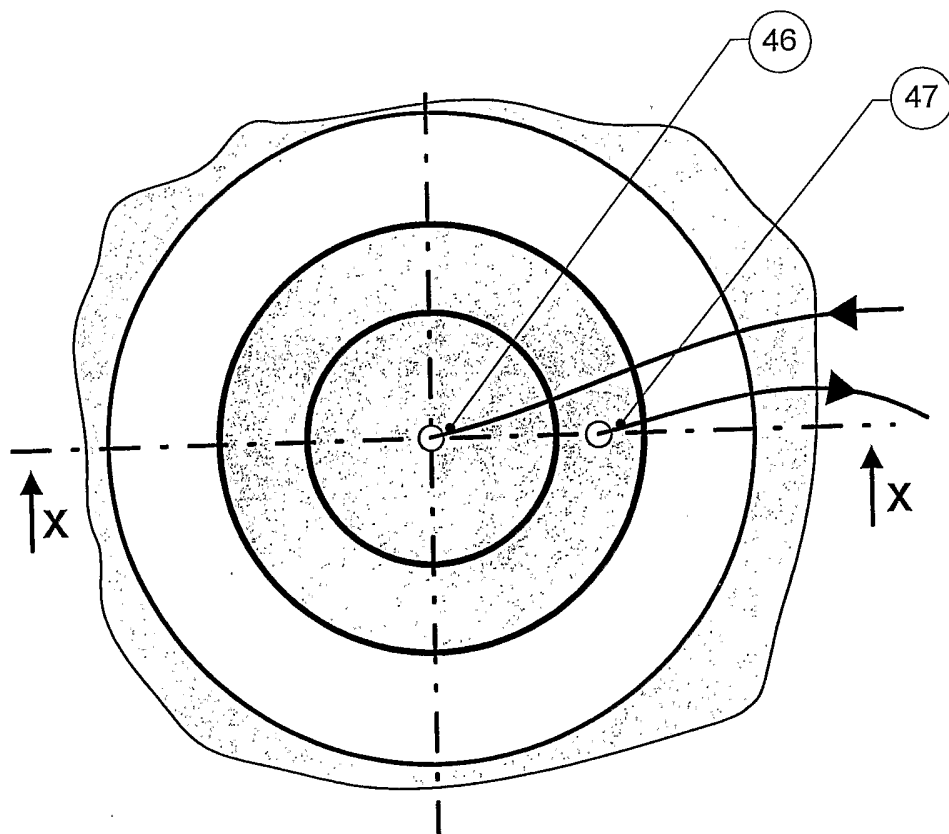
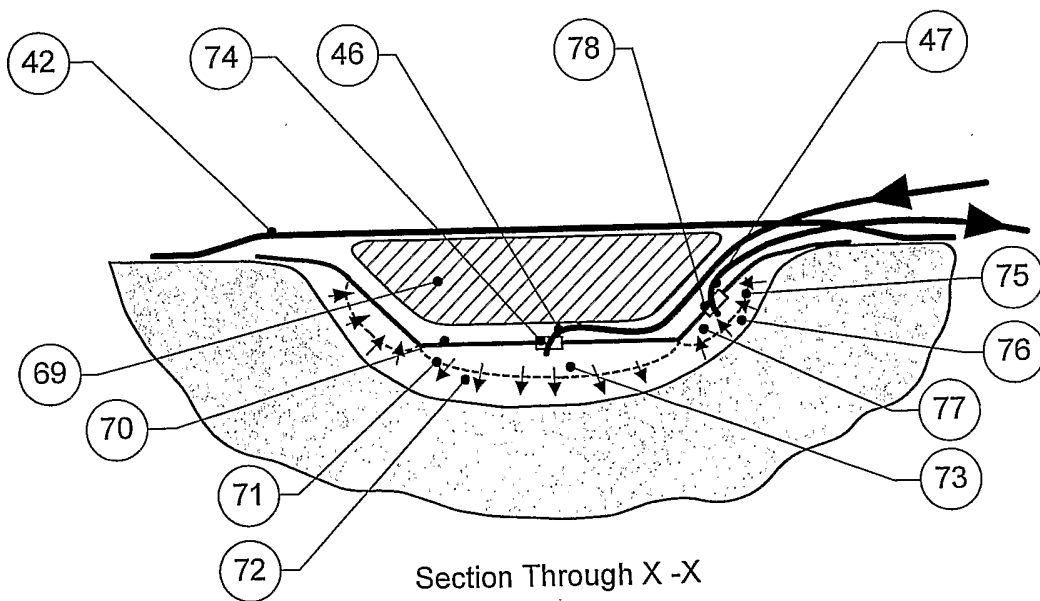

Figure 5a



Section Through X-X

Figure 5b

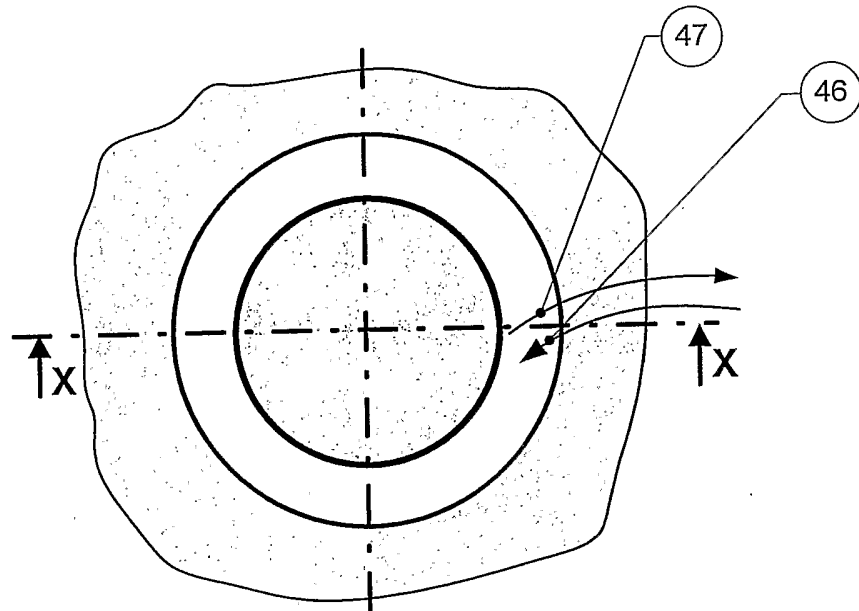

Figure 6a

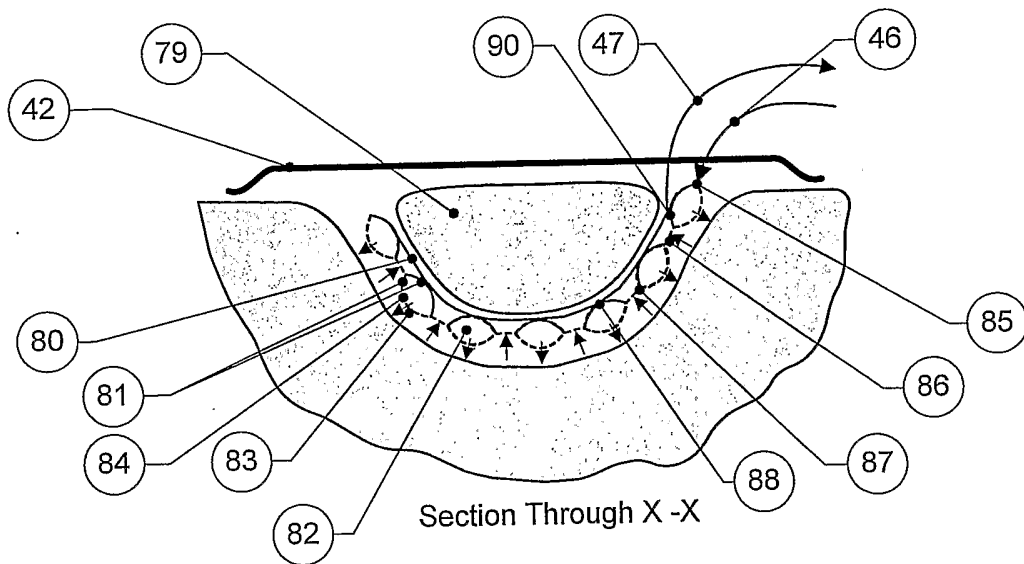

Figure 6b

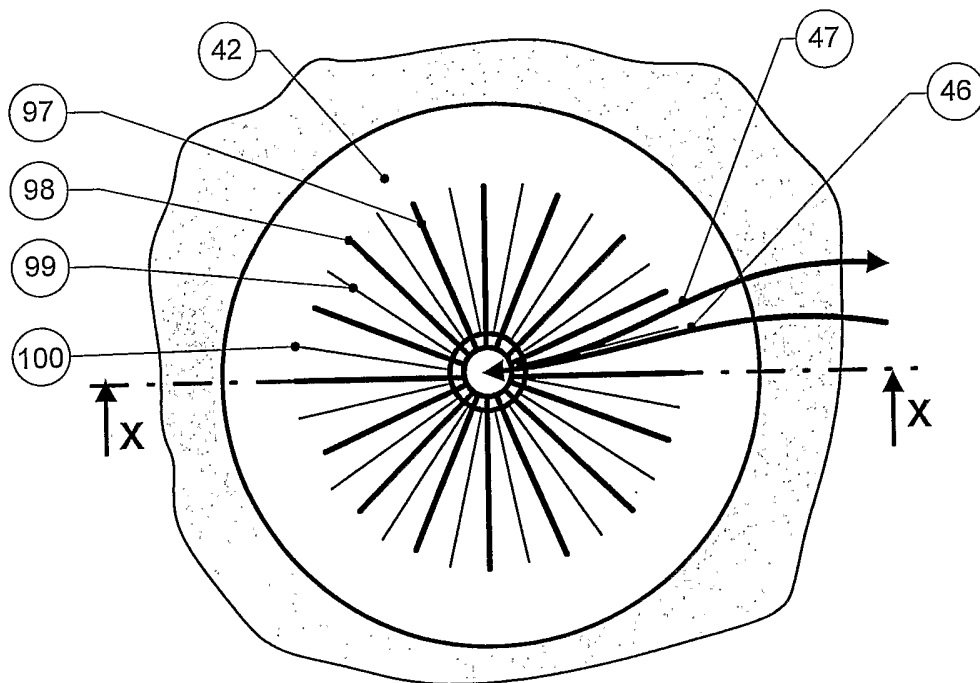
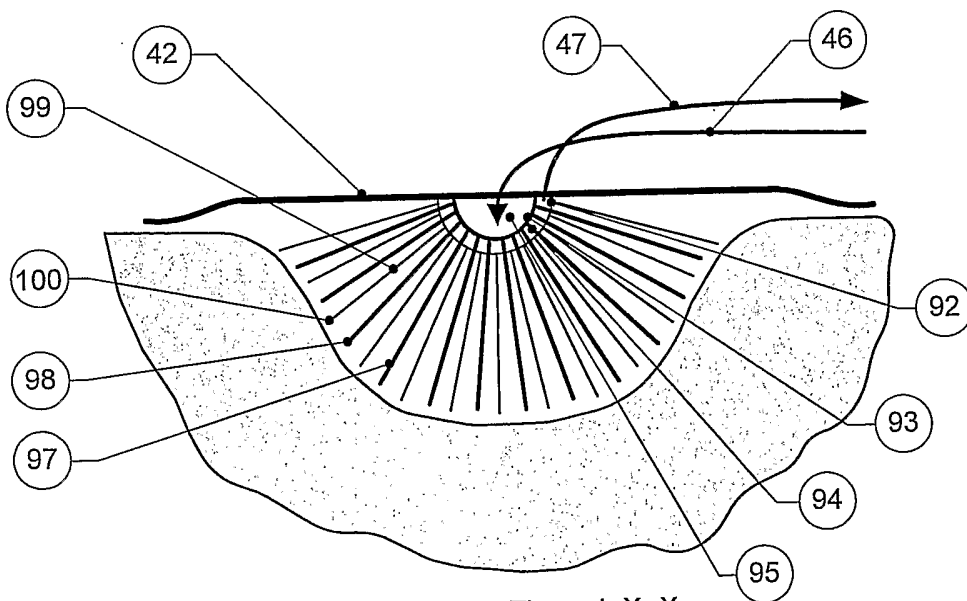

Figure 7a



Section Through X -X

Figure 7b

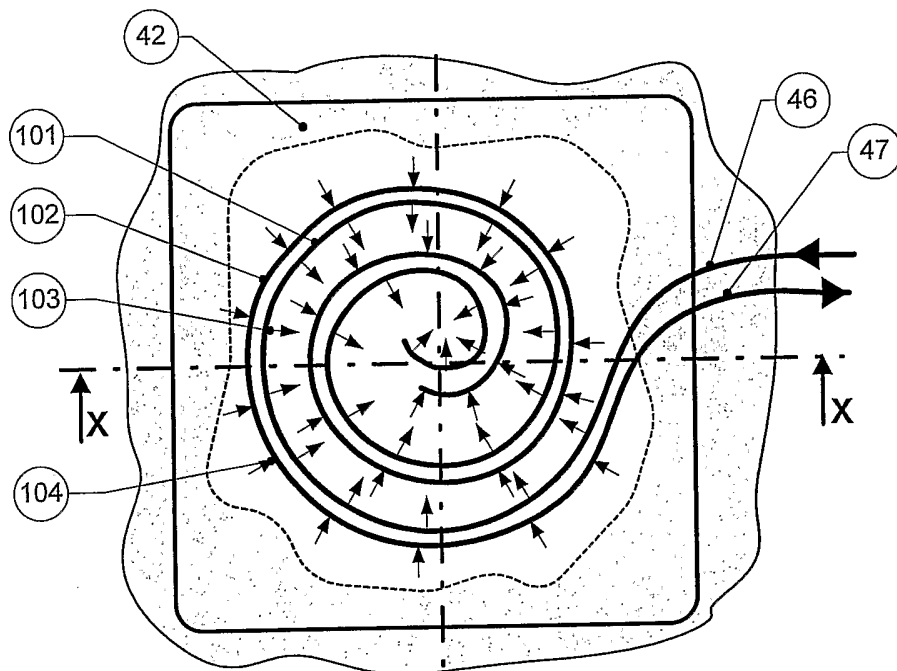

Figure 8a

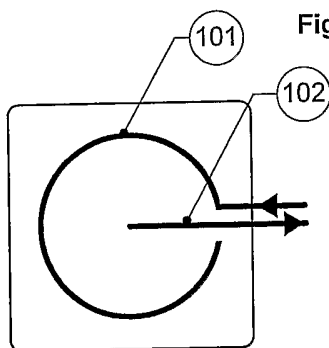

Figure 8b

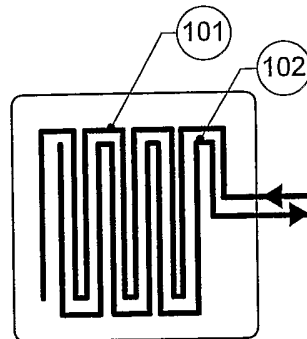
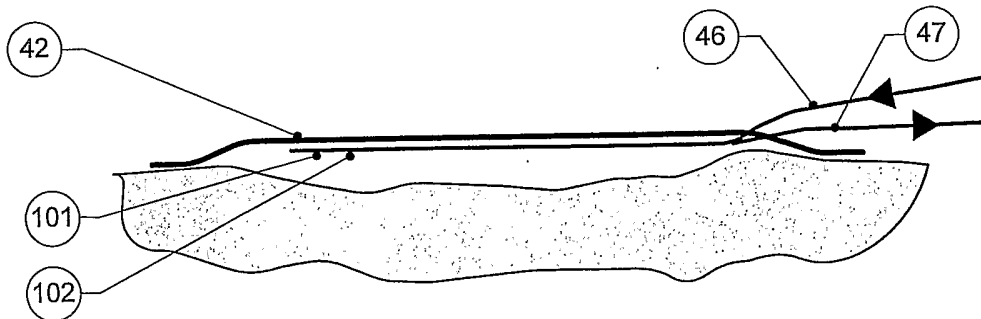

Figure 8c



Section Through X -X

Figure 8d

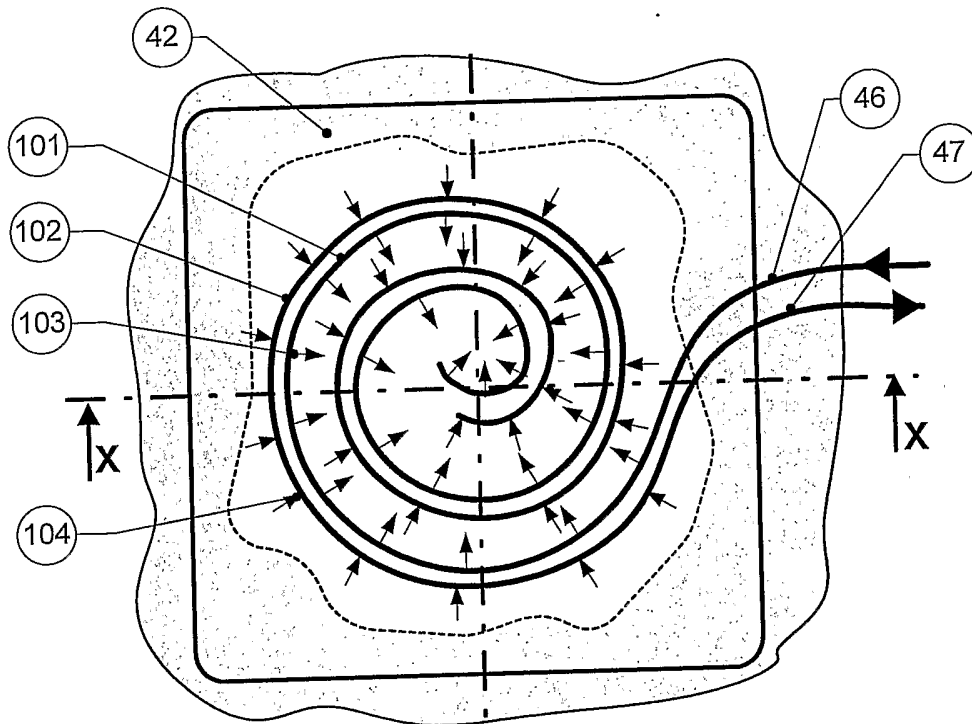
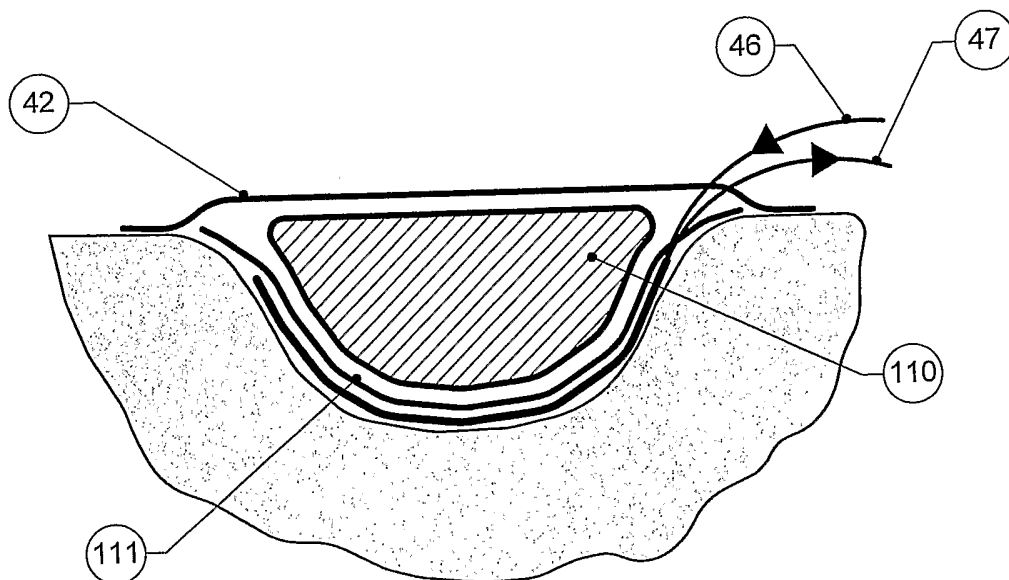

Figure 9a



Section Through X -X

Figure 9b

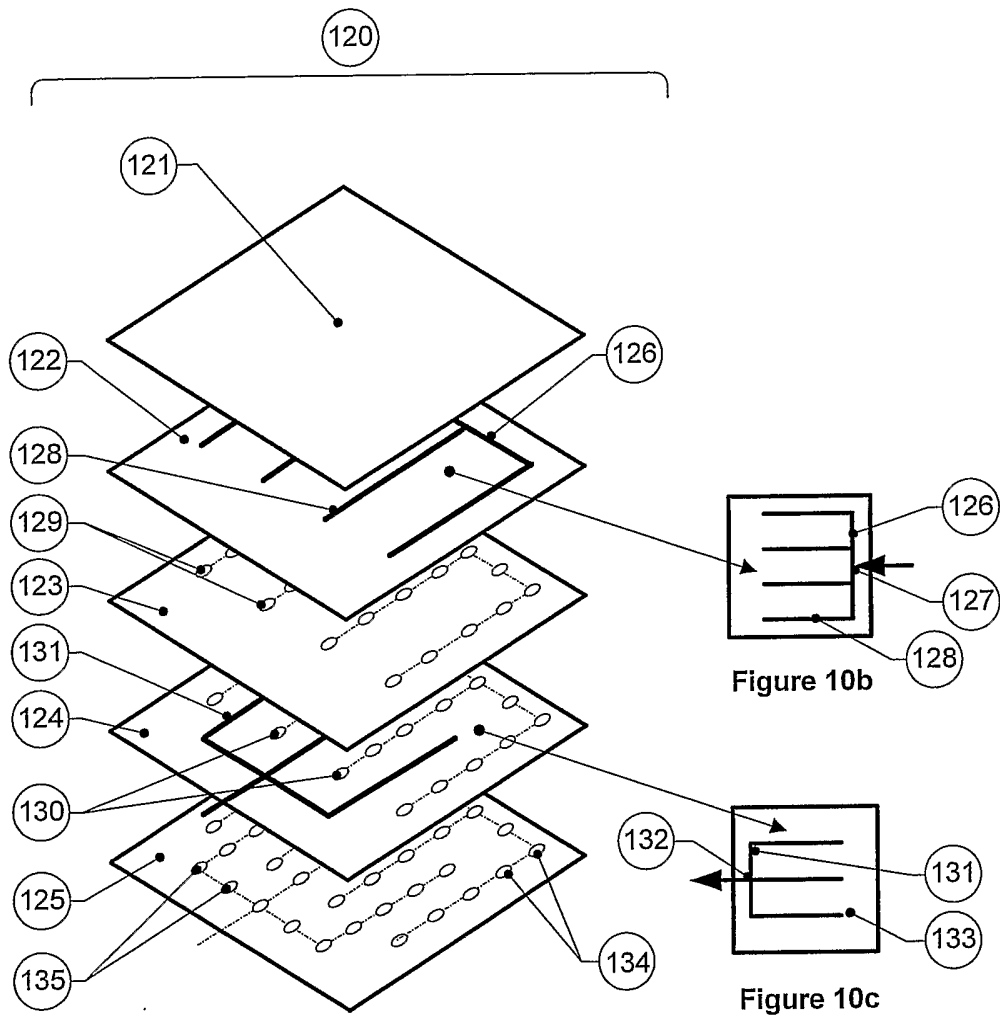

Figure 10a

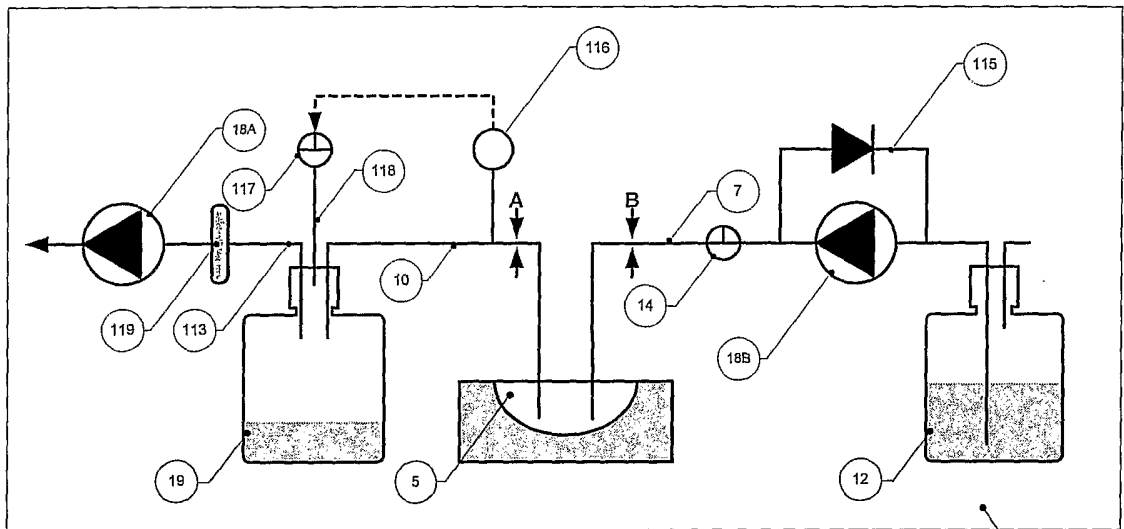

Figure 11a

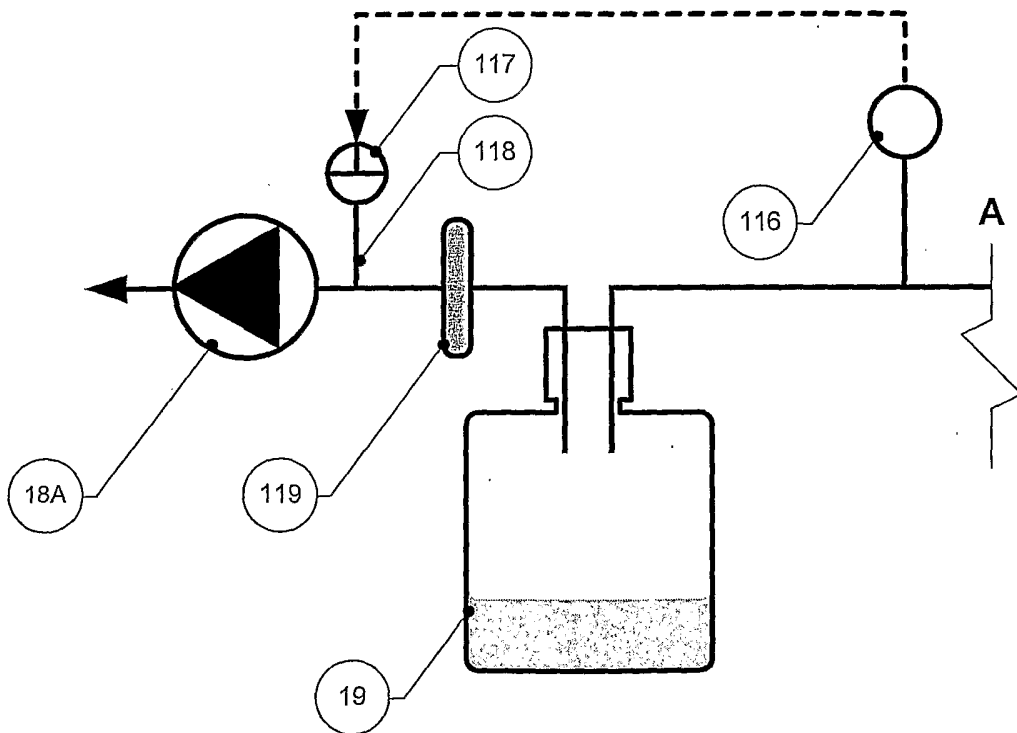

Figure 11b

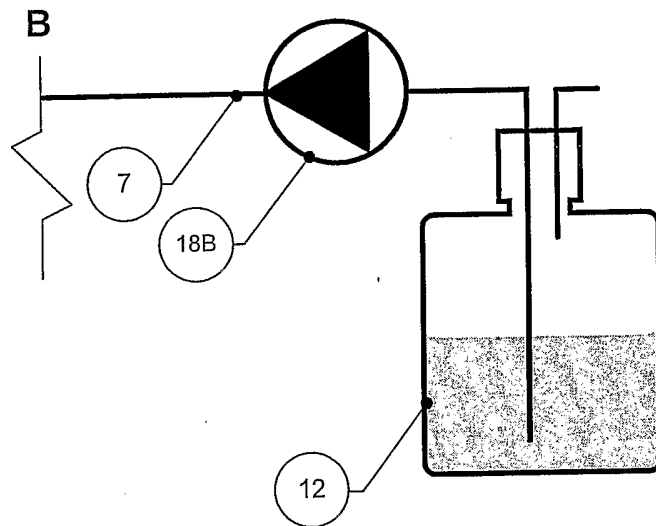

Figure 11c

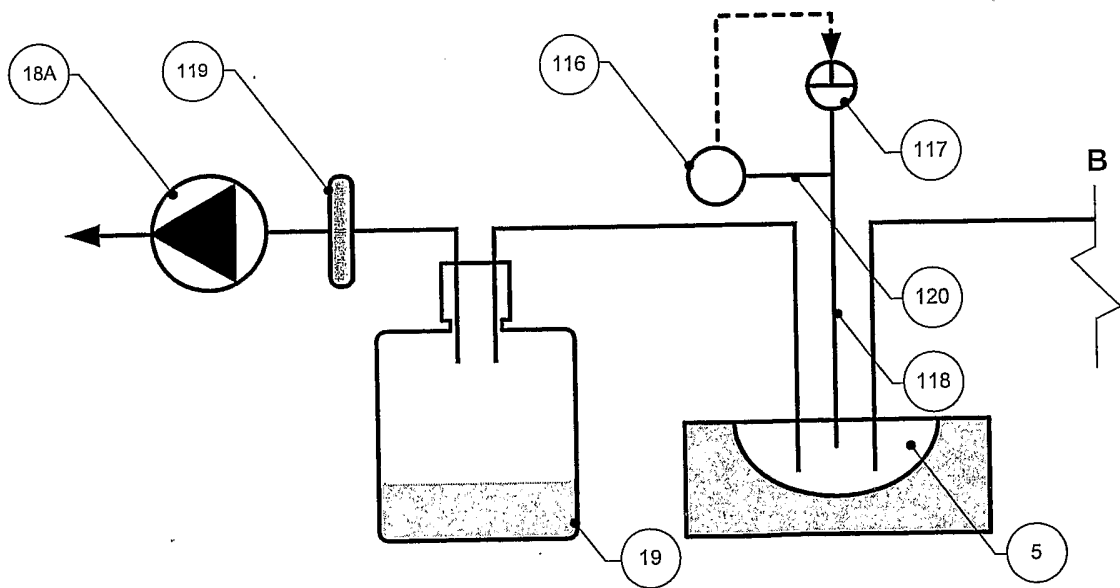

Figure 11d

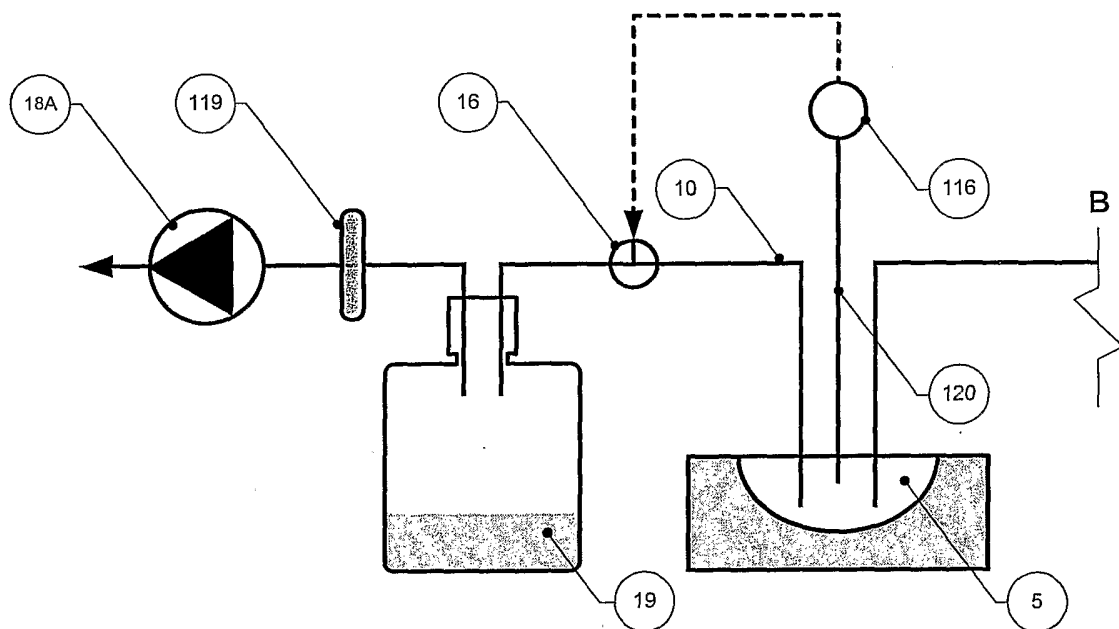

Figure 12a

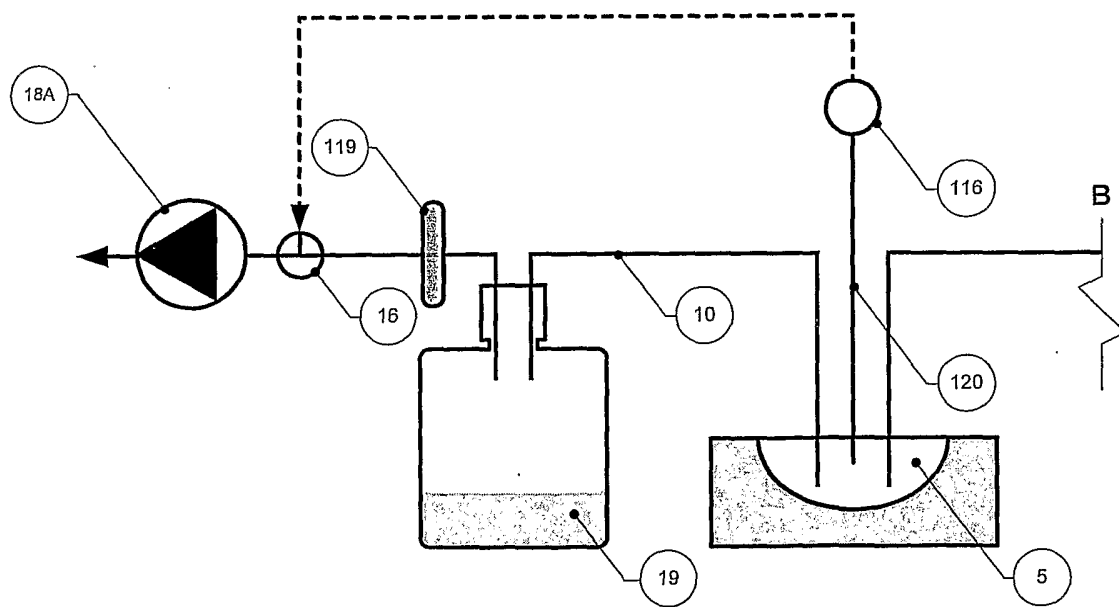

Figure 12b

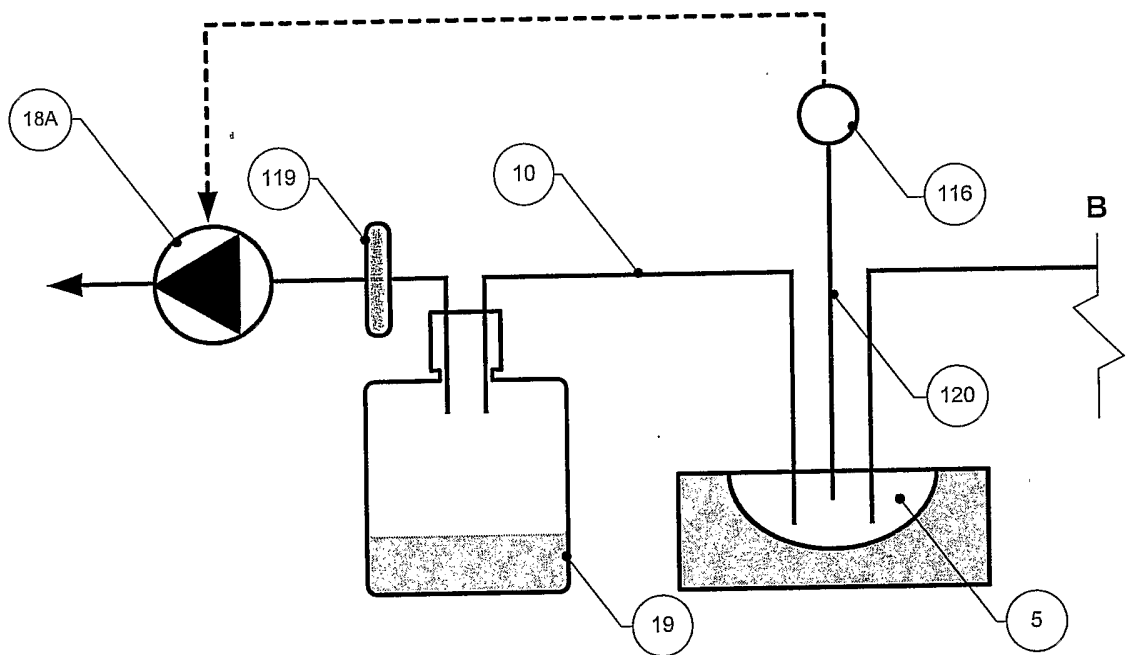

Figure 12c

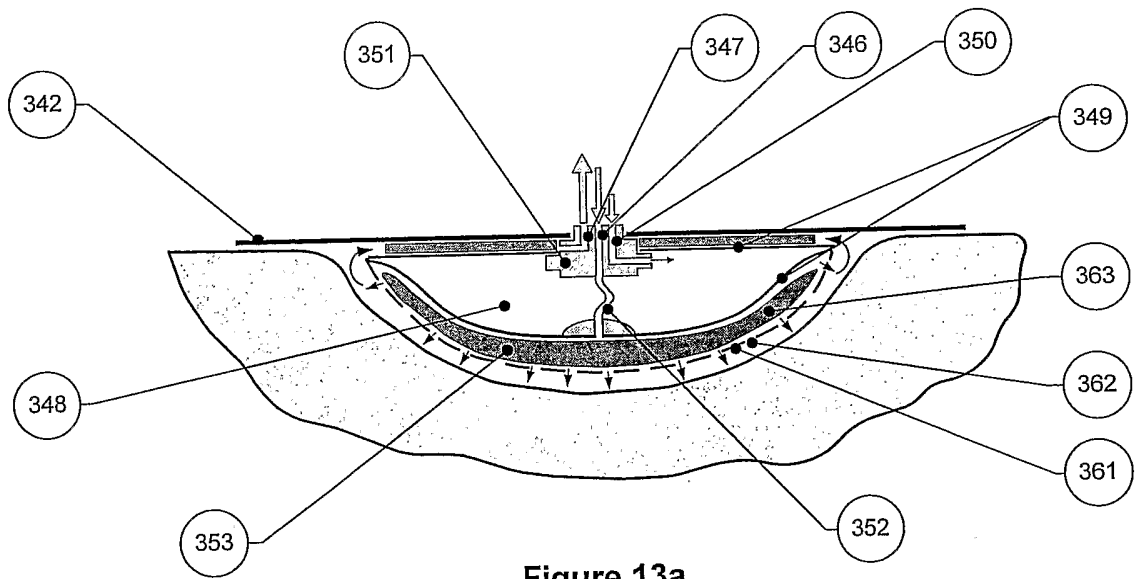

Figure 13a

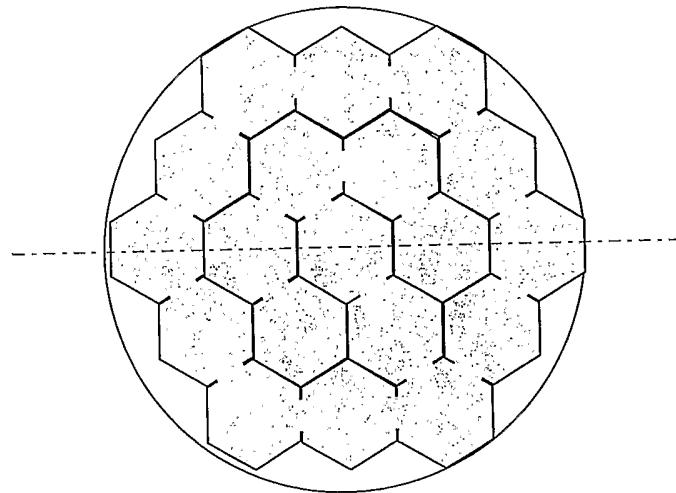

Figure 13b

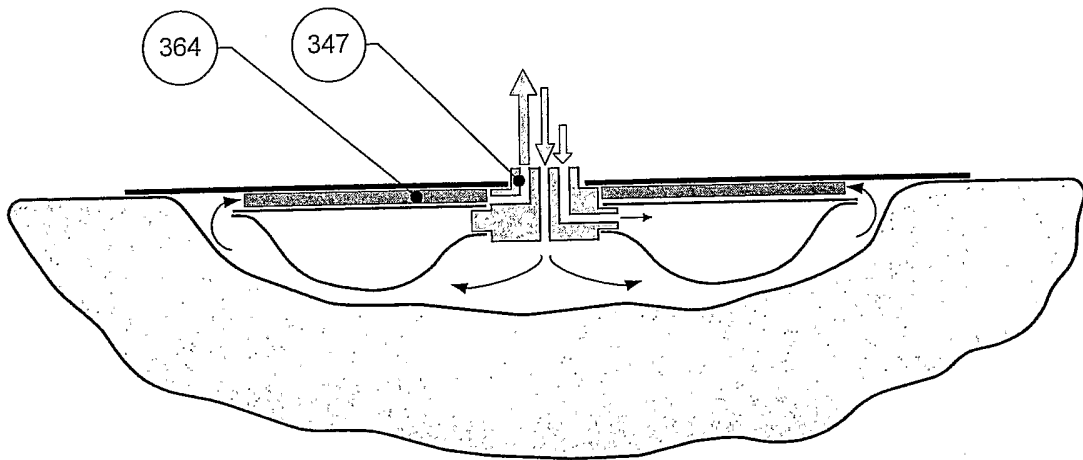

Figure 14

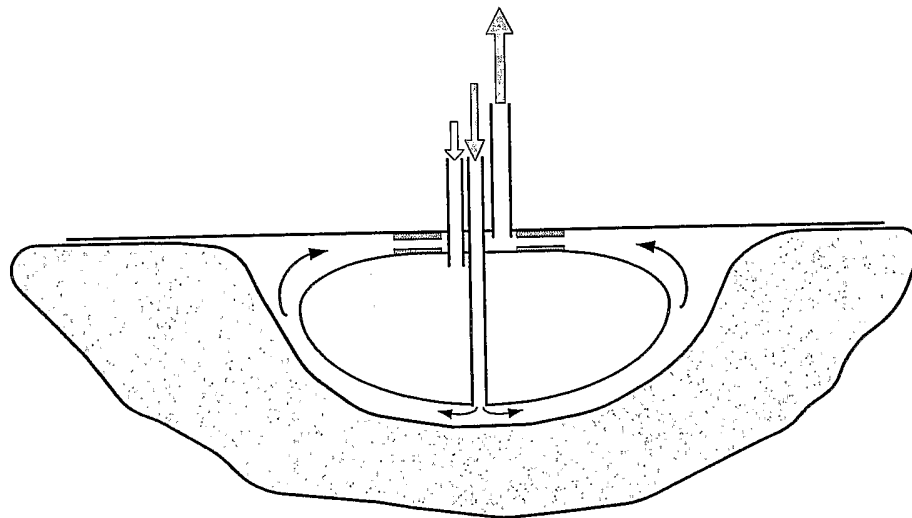
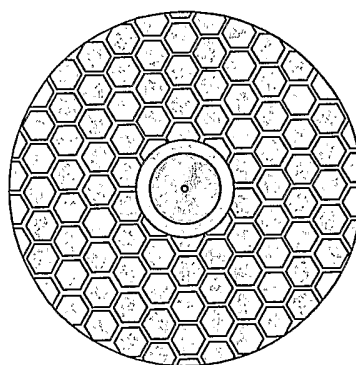
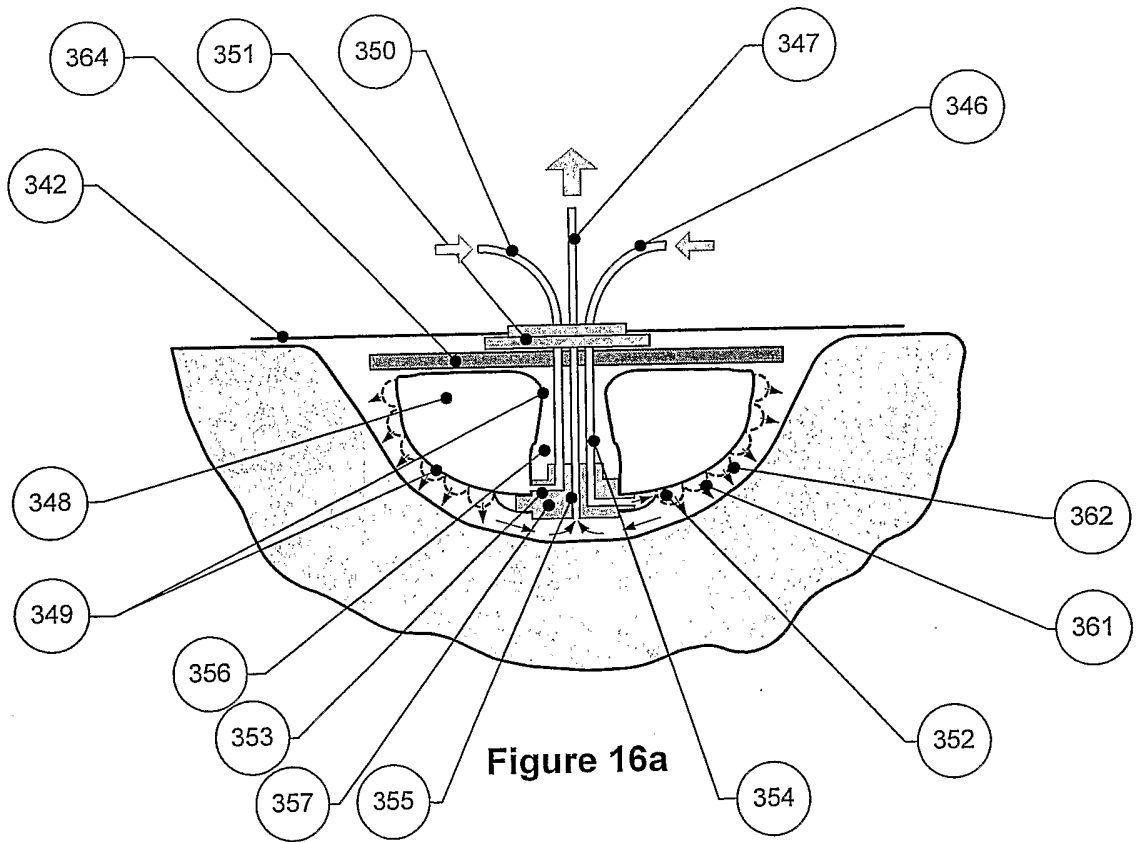

Figure 15



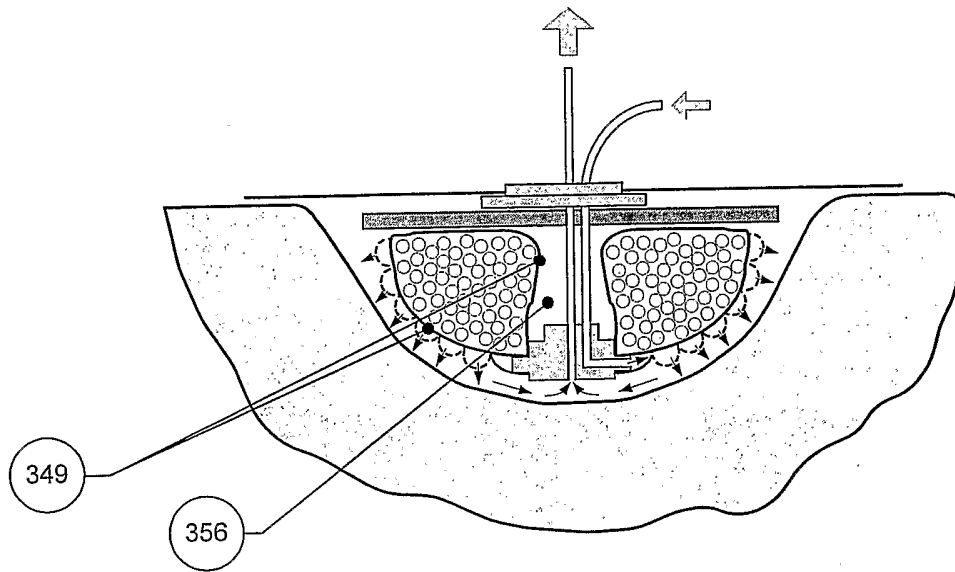

Figure 17

5

10

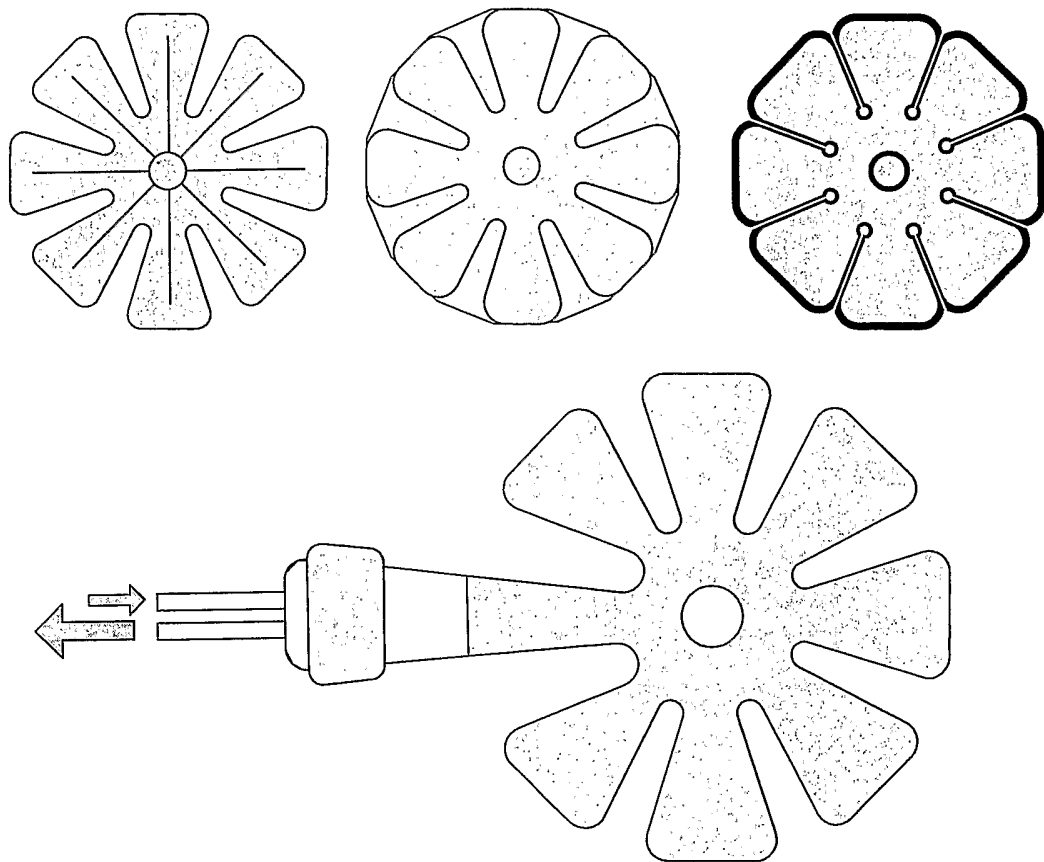
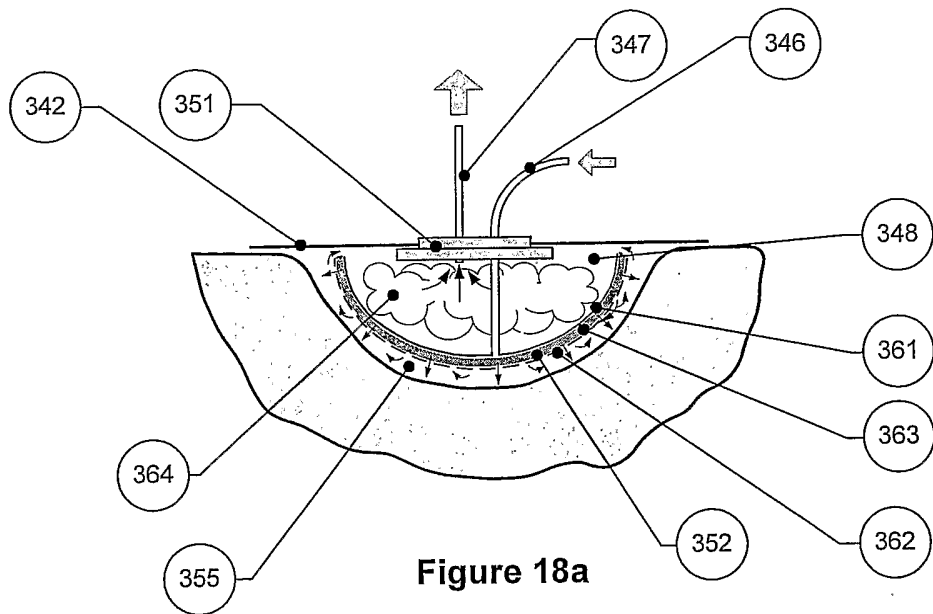

Figure 18b

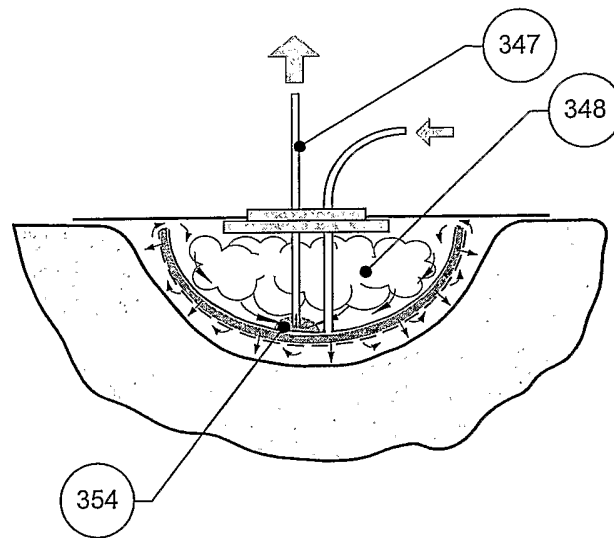

Figure 19

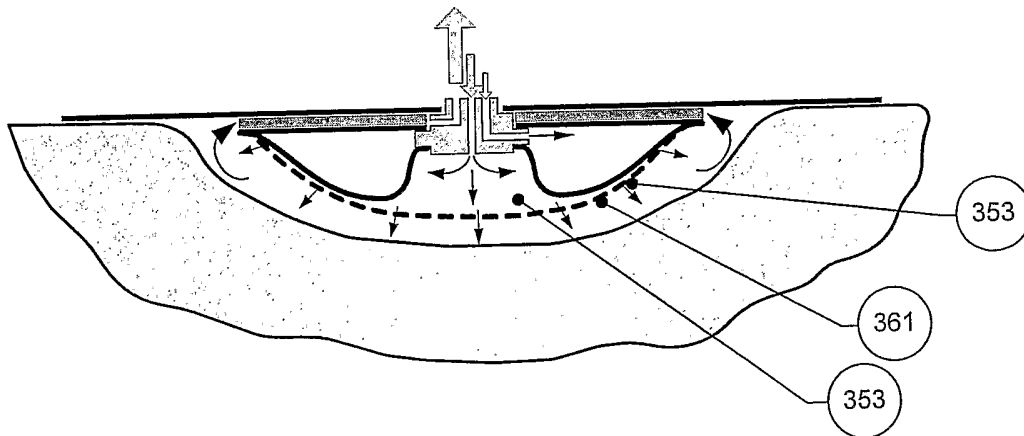

Figure 21

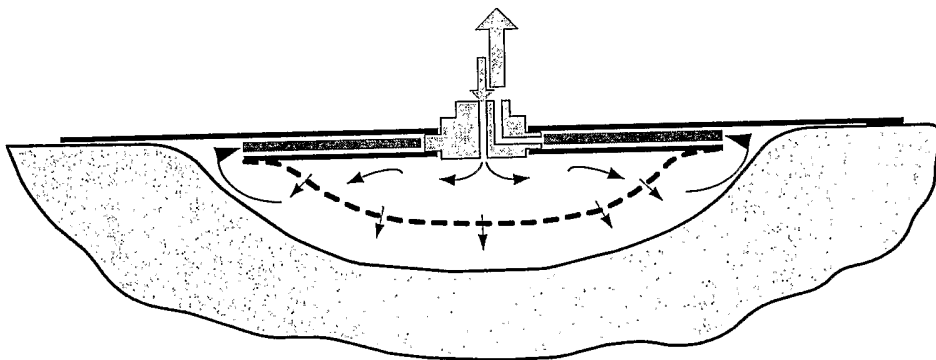

Figure 22

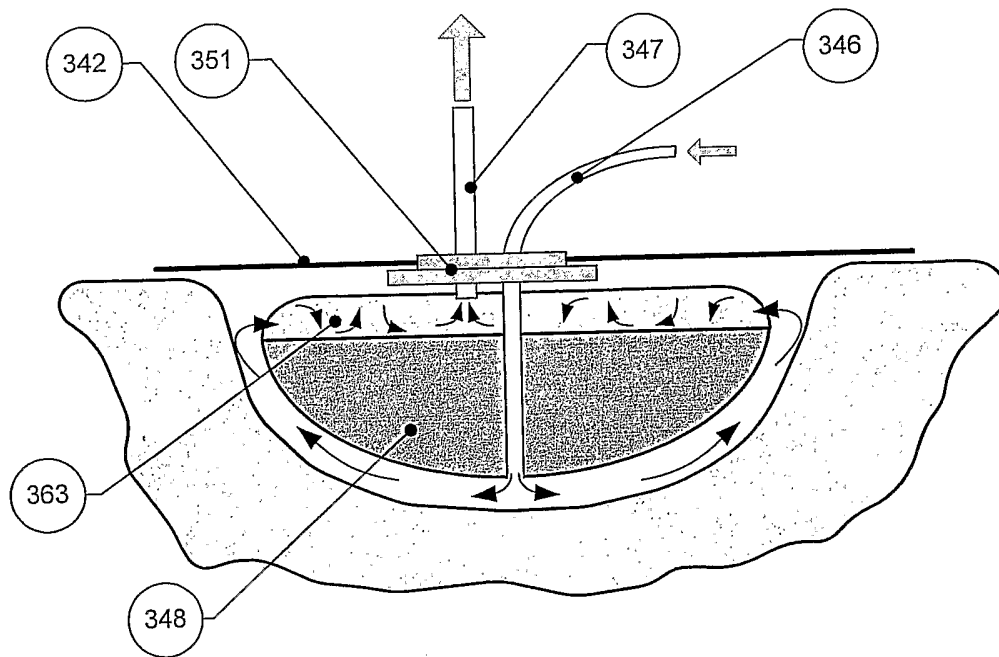

Figure 23

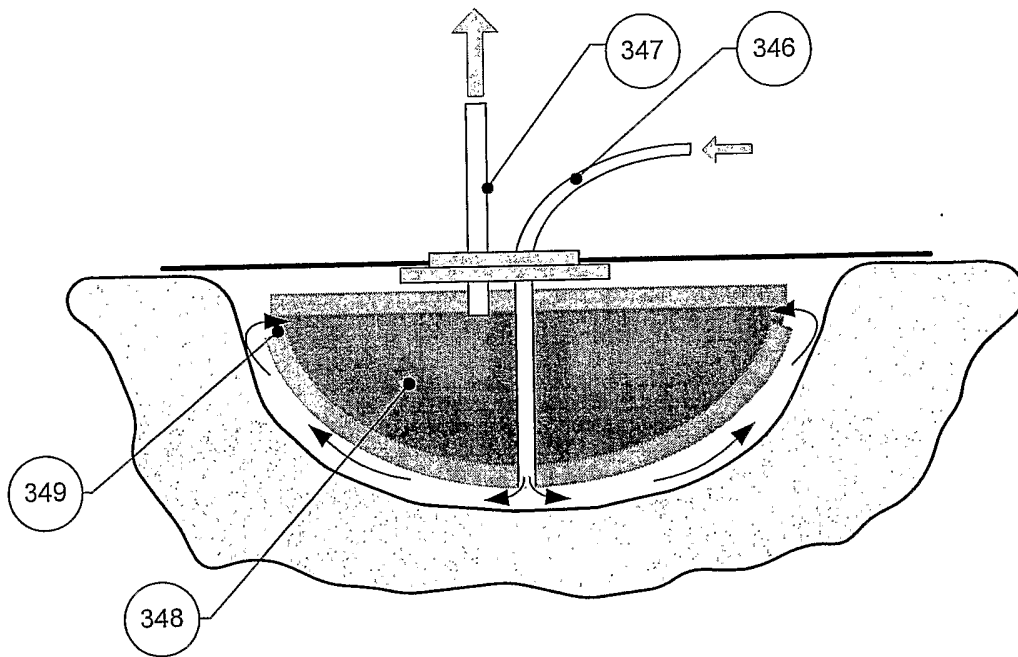

Figure 24

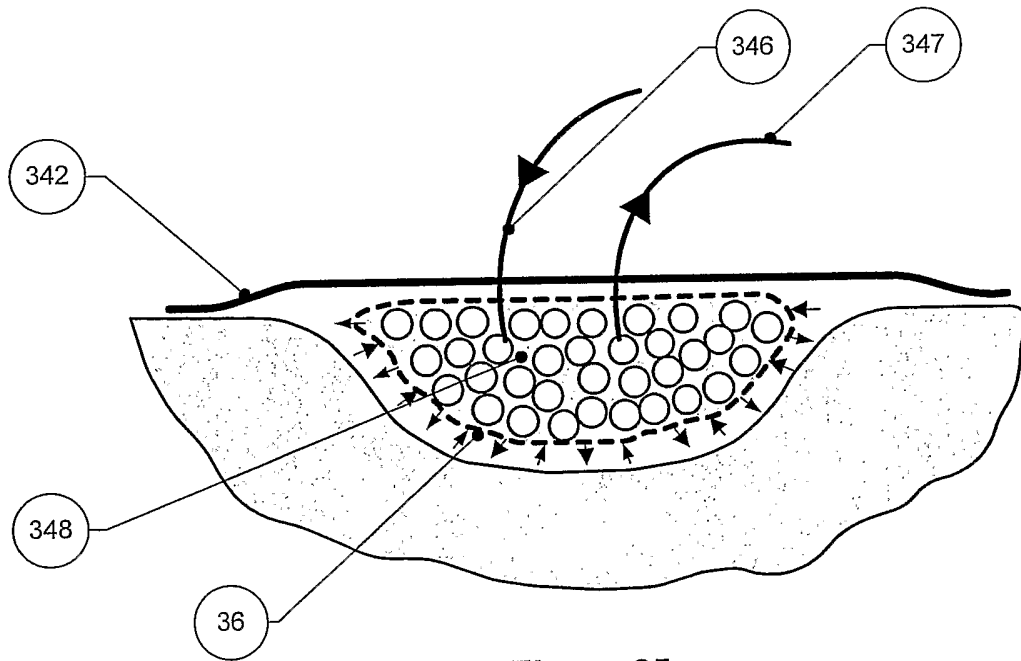

Figure 25

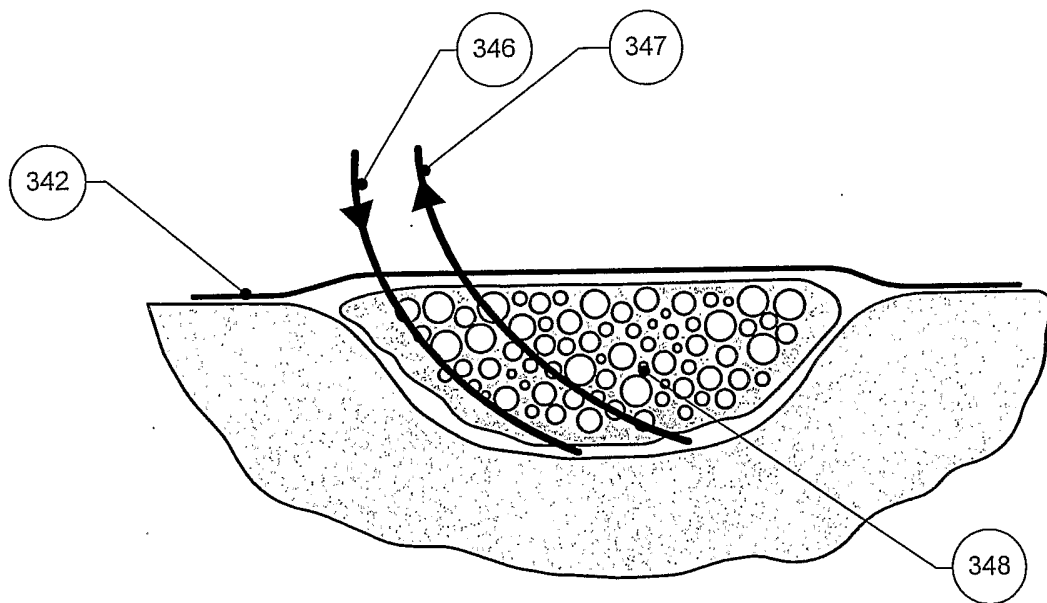

Figure 26

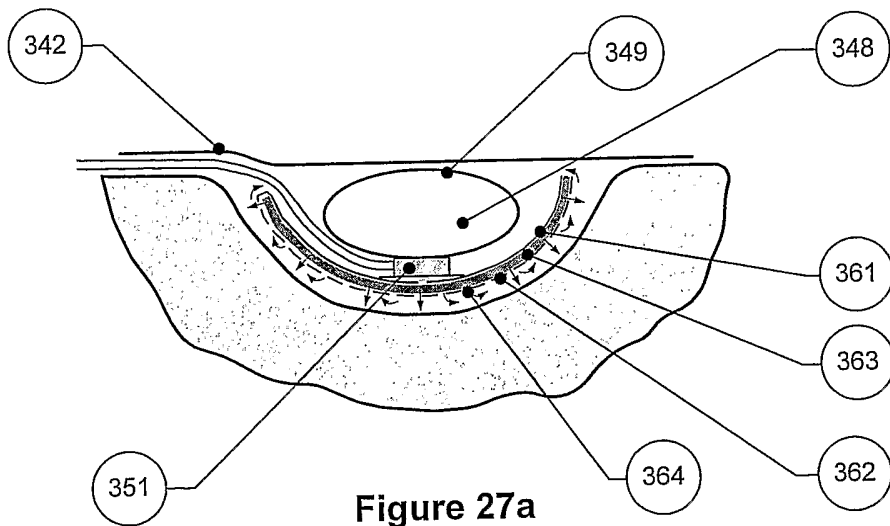

Figure 27a

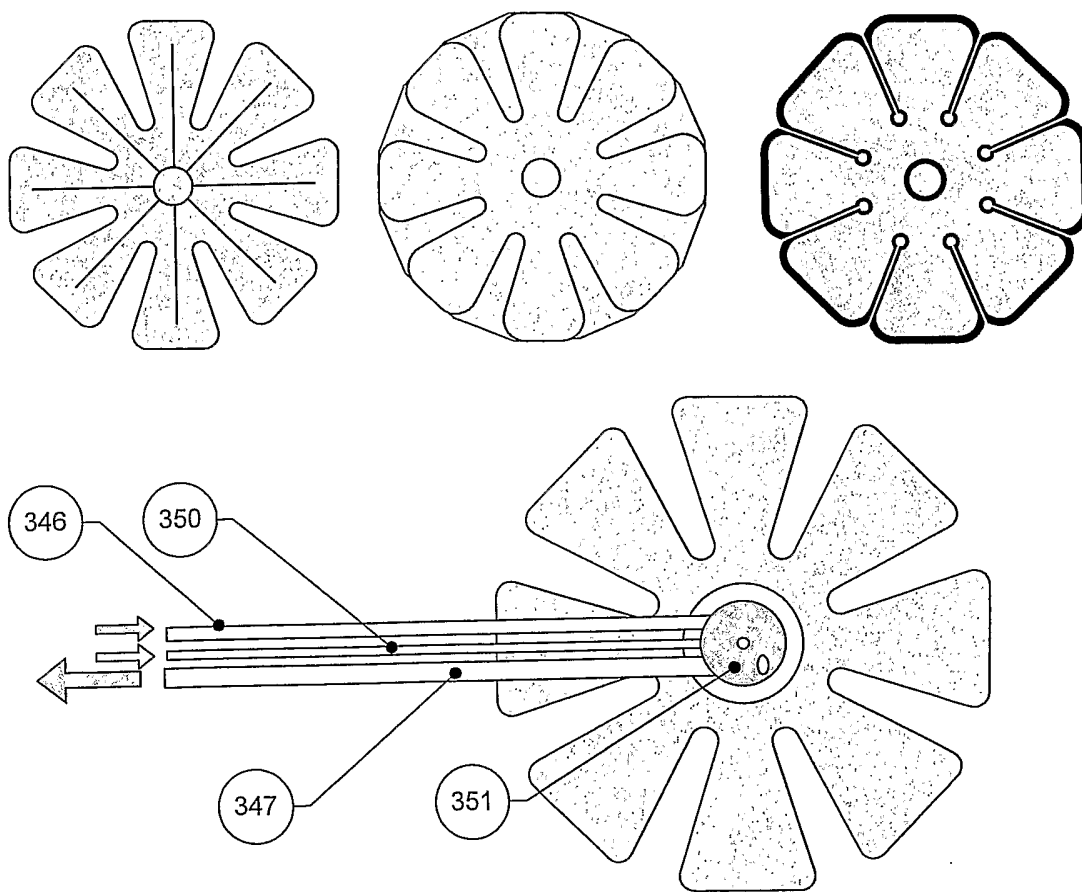

Figure 27b

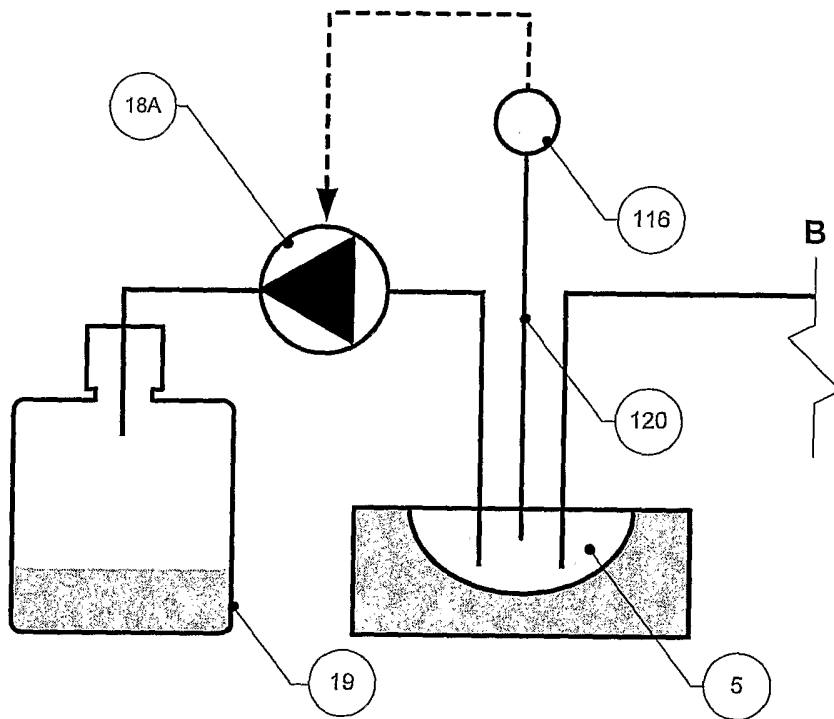

Figure 28a

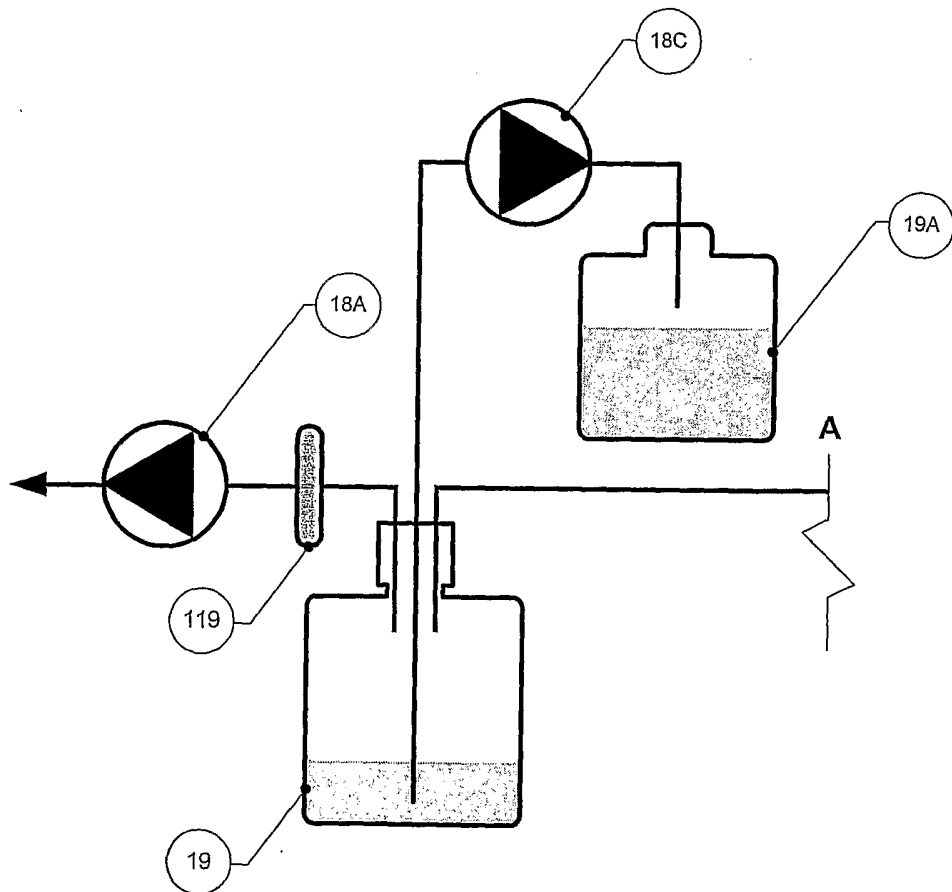

Figure 28b

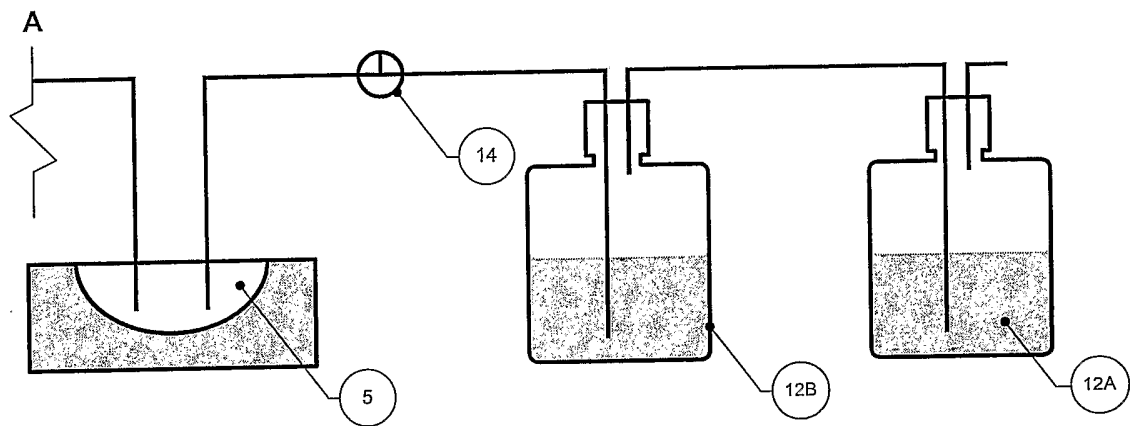

Figure 29

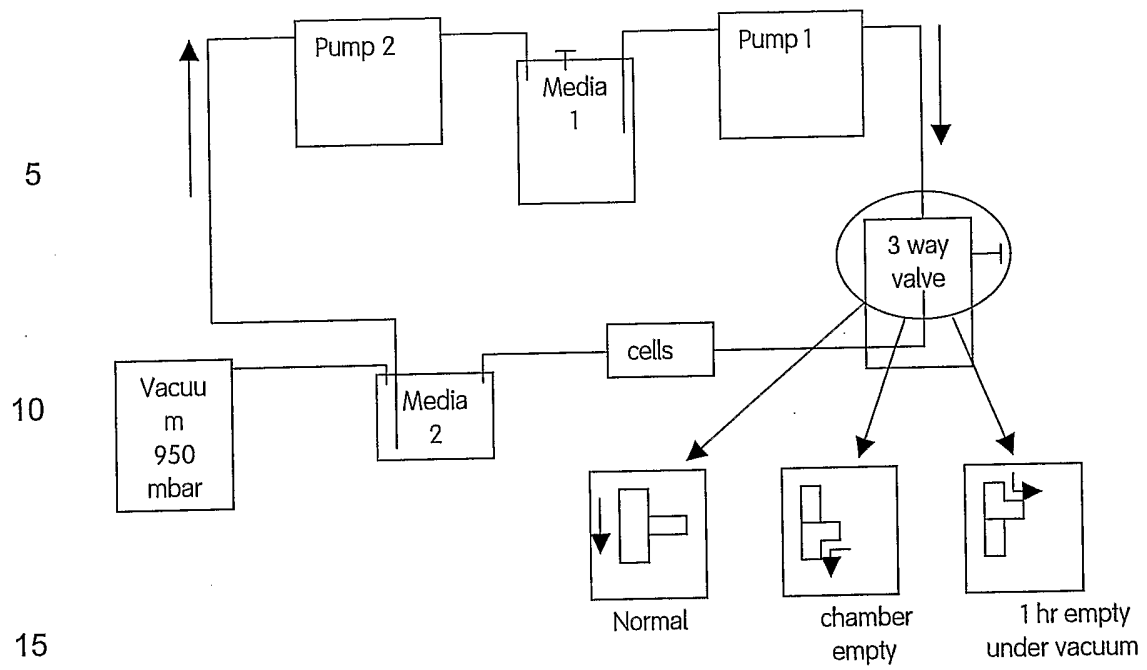

Figure 30

INTERNATIONAL SEARCH REPORT

International Application No
PCT/GB2005/001603

A. CLASSIFICATION OF SUBJECT MATTER IPC 7 A61M3/02 A61M27/00 A61M35/00		
According to International Patent Classification (IPC) or to both national classification and IPC		
B. FIELDS SEARCHED Minimum documentation searched (classification system followed by classification symbols) IPC 7 A61M		
Documentation searched other than minimum documentation to the extent that such documents are included in the fields searched		
Electronic data base consulted during the international search (name of data base and, where practical, search terms used) EPO-Internal		
C. DOCUMENTS CONSIDERED TO BE RELEVANT		
Category °	Citation of document, with indication, where appropriate, of the relevant passages	Relevant to claim No.
X	US 2002/161346 A1 (LOCKWOOD JEFFREY S ET AL) 31 October 2002 (2002-10-31) the whole document -----	1-9
X	DE 39 35 818 A1 (NEHER, WOLFGANG, DR., 7750 KONSTANZ, DE) 2 May 1991 (1991-05-02) the whole document -----	1,9
X	US 2003/021775 A1 (FREEMAN AMIHAY) 30 January 2003 (2003-01-30) the whole document -----	1-9
X	US 6 458 109 B1 (HENLEY ALAN WAYNE ET AL) 1 October 2002 (2002-10-01) column 2, line 16 - column 3, line 30; claims 32,35,39,41; figures 1,9,21,30,31 ----- -/--	9
<input checked="" type="checkbox"/> Further documents are listed in the continuation of box C. <input checked="" type="checkbox"/> Patent family members are listed in annex.		
° Special categories of cited documents :		
"A" document defining the general state of the art which is not considered to be of particular relevance "E" earlier document but published on or after the international filing date "L" document which may throw doubts on priority claim(s) or which is cited to establish the publication date of another citation or other special reason (as specified) "O" document referring to an oral disclosure, use, exhibition or other means "P" document published prior to the international filing date but later than the priority date claimed	"T" later document published after the international filing date or priority date and not in conflict with the application but cited to understand the principle or theory underlying the invention "X" document of particular relevance; the claimed invention cannot be considered novel or cannot be considered to involve an inventive step when the document is taken alone "Y" document of particular relevance; the claimed invention cannot be considered to involve an inventive step when the document is combined with one or more other such documents, such combination being obvious to a person skilled in the art. "&" document member of the same patent family	
Date of the actual completion of the international search <p style="text-align: center; font-weight: bold;">8 July 2005</p>	Date of mailing of the international search report <p style="text-align: center; font-weight: bold;">27/07/2005</p>	
Name and mailing address of the ISA European Patent Office, P.B. 5818 Patentlaan 2 NL - 2280 HV Rijswijk Tel. (+31-70) 340-2040, Tx. 31 651 epo nl, Fax: (+31-70) 340-3016	Authorized officer <p style="text-align: center; font-weight: bold;">Borowski, A</p>	

INTERNATIONAL SEARCH REPORT

International Application No
PCT/GB2005/001603

C.(Continuation) DOCUMENTS CONSIDERED TO BE RELEVANT		
Category °	Citation of document, with indication, where appropriate, of the relevant passages	Relevant to claim No.
X	GB 1 549 756 A (EVERETT W; WESTABY S) 8 August 1979 (1979-08-08) the whole document -----	9
X	DE 40 12 232 A1 (GROSS, FRANZ JOSEF, 5419 LINKENBACH, DE) 17 October 1991 (1991-10-17) the whole document -----	9
X	EP 0 355 186 A (E.R. SQUIBB & SONS, INC) 28 February 1990 (1990-02-28) the whole document -----	9

INTERNATIONAL SEARCH REPORT

International application No.
PCT/GB2005/001603

Box II Observations where certain claims were found unsearchable (Continuation of item 2 of first sheet)

This International Search Report has not been established in respect of certain claims under Article 17(2)(a) for the following reasons:

1. Claims Nos.: 10
because they relate to subject matter not required to be searched by this Authority, namely:
Rule 39.1(iv) PCT - Method for treatment of the human or animal body by therapy: a method of treating wounds to promote wound healing.

2. Claims Nos.:
because they relate to parts of the International Application that do not comply with the prescribed requirements to such an extent that no meaningful International Search can be carried out, specifically:

3. Claims Nos.:
because they are dependent claims and are not drafted in accordance with the second and third sentences of Rule 6.4(a).

Box III Observations where unity of invention is lacking (Continuation of item 3 of first sheet)

This International Searching Authority found multiple inventions in this international application, as follows:

1. As all required additional search fees were timely paid by the applicant, this International Search Report covers all searchable claims.

2. As all searchable claims could be searched without effort justifying an additional fee, this Authority did not invite payment of any additional fee.

3. As only some of the required additional search fees were timely paid by the applicant, this International Search Report covers only those claims for which fees were paid, specifically claims Nos.:

4. No required additional search fees were timely paid by the applicant. Consequently, this International Search Report is restricted to the invention first mentioned in the claims; it is covered by claims Nos.:

Remark on Protest

- The additional search fees were accompanied by the applicant's protest.
- No protest accompanied the payment of additional search fees.

INTERNATIONAL SEARCH REPORT

International Application No
PCT/GB2005/001603

Patent document cited in search report		Publication date	Patent family member(s)	Publication date
US 2002161346	A1	31-10-2002	US 2002082567 A1	27-06-2002
			US 2002065494 A1	30-05-2002
			AU 2002346521 A1	10-06-2003
			CA 2467837 A1	05-06-2003
			EP 1448261 A1	25-08-2004
			WO 03045492 A1	05-06-2003
			US 2005131327 A1	16-06-2005
			AU 1786902 A	11-06-2002
			CA 2430313 A1	06-06-2002
			EP 1339366 A2	03-09-2003
			WO 0243634 A2	06-06-2002
			US 2004064111 A1	01-04-2004
DE 3935818	A1	02-05-1991	DE 4111122 A1	29-04-1993
US 2003021775	A1	30-01-2003	EP 1443988 A1	11-08-2004
			WO 03011369 A1	13-02-2003
			US 2004186421 A1	23-09-2004
US 6458109	B1	01-10-2002	AT 288775 T	15-02-2005
			AU 757347 B2	20-02-2003
			AU 5255599 A	28-02-2000
			CA 2338443 A1	17-02-2000
			DE 69923689 D1	17-03-2005
			DE 69923689 T2	07-07-2005
			EP 1100574 A1	23-05-2001
			HU 0103545 A2	28-02-2002
			JP 2002524109 T	06-08-2002
			NO 20010485 A	29-01-2001
			PL 364754 A1	13-12-2004
			WO 0007653 A1	17-02-2000
GB 1549756	A	08-08-1979	CA 1127488 A1	13-07-1982
			DE 2809828 A1	21-09-1978
			DE 7806873 U1	06-07-1978
			FR 2382900 A1	06-10-1978
			JP 1338799 C	29-09-1986
			JP 53113188 A	03-10-1978
			JP 61001148 B	14-01-1986
DE 4012232	A1	17-10-1991	NONE	
EP 0355186	A	28-02-1990	US 4778446 A	18-10-1988
			EP 0355186 A1	28-02-1990