



(19) **United States**
(12) **Patent Application Publication**
Pastrick et al.

(10) **Pub. No.: US 2008/0219019 A1**
(43) **Pub. Date: Sep. 11, 2008**

(54) **VEHICLE EXTERIOR MIRROR SYSTEM WITH SIGNAL LIGHT**

(75) Inventors: **Todd W. Pastrick**, Spring Lake, MI (US); **Michiel P. van de Ven**, Zeeland, MI (US); **Peter J. Whitehead**, Grand Rapids, MI (US); **Rick Mousseau**, Holland, MI (US); **Niall R. Lynam**, Holland, MI (US)

Correspondence Address:
VAN DYKE, GARDNER, LINN & BURKHART, LLP
SUITE 207, 2851 CHARLEVOIX DRIVE, S.E.
GRAND RAPIDS, MI 49546 (US)

(73) Assignee: **DONNELLY CORPORATION**, Holland, MI (US)

(21) Appl. No.: **12/122,005**

(22) Filed: **May 16, 2008**

Related U.S. Application Data

(60) Division of application No. 11/649,143, filed on Jan. 3, 2007, now Pat. No. 7,377,675, which is a continuation of application No. 10/407,555, filed on Apr. 4, 2003, now Pat. No. 7,168,830, which is a division of application No. 09/690,048, filed on Oct. 16, 2000, now Pat. No. 6,568,839, which is a division of application No. 09/102,414, filed on Jun. 22, 1998, now Pat. No. 6,176,602, which is a continuation-in-part of application No. 08/934,490, filed on Sep. 19, 1997, now Pat. No.

5,863,116, which is a continuation of application No. 08/607,285, filed on Feb. 26, 1996, now Pat. No. 5,669,705, which is a continuation of application No. 08/333,412, filed on Nov. 2, 1994, now Pat. No. 5,497,305, which is a continuation of application No. 08/011,947, filed on Feb. 1, 1993, now Pat. No. 5,371,659, said application No. 09/102,414 is a continuation-in-part of application No. 08/687,628, filed on Jul. 26, 1996, now Pat. No. 5,823,654, which is a continuation-in-part of application No. 08/607,284, filed on Feb. 26, 1996, now Pat. No. 5,669,704, which is a continuation of application No. 08/426,591, filed on Apr. 21, 1995, now Pat. No. 5,497,306, which is a continuation-in-part of application No. 08/333,412, filed on Nov. 2, 1994, now Pat. No. 5,497,305, which is a continuation of application No. 08/011,947, filed on Feb. 1, 1993, now Pat. No. 5,371,659.

Publication Classification

(51) **Int. Cl.**
B60Q 1/26 (2006.01)
B60Q 1/24 (2006.01)
(52) **U.S. Cl.** **362/494; 362/540**

(57) **ABSTRACT**

An exterior mirror assembly for a vehicle includes a signal light or security light that provides illumination at a side of the vehicle. The exterior mirror assembly includes a housing with a reflective element, and may include a positioning device for adjusting the position of the reflective element in the housing. The signal light includes a light source and may be adapted to project light from a non-folding portion or support member of the mirror housing.

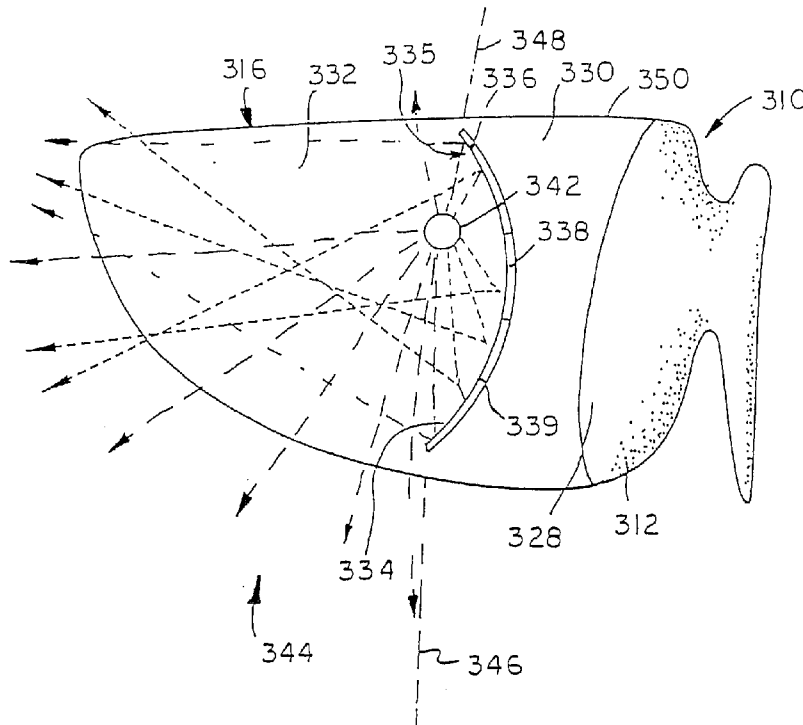

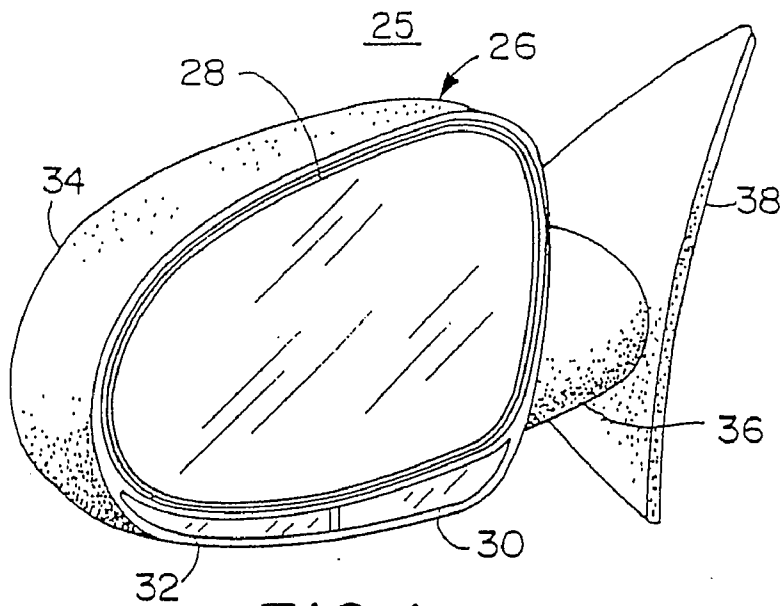

FIG. 1

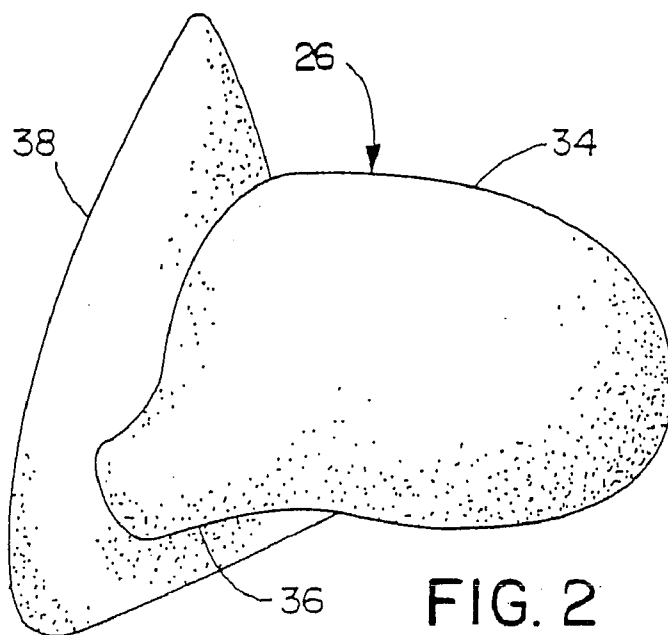

FIG. 2

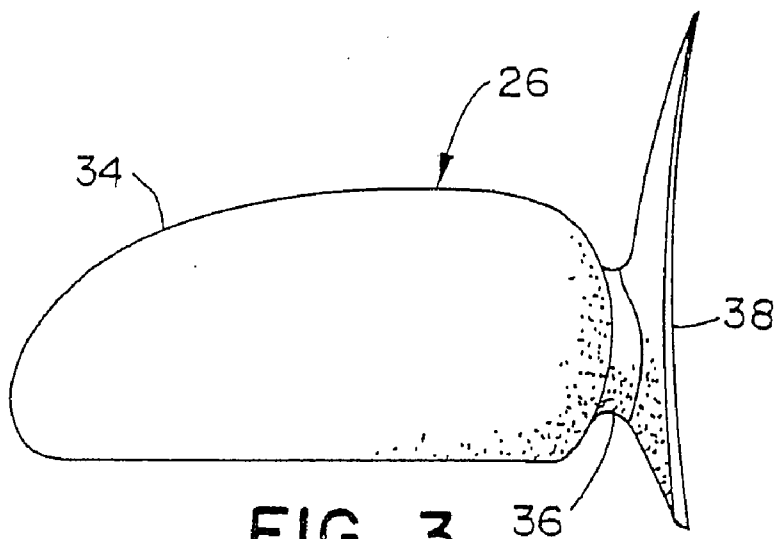

FIG. 3

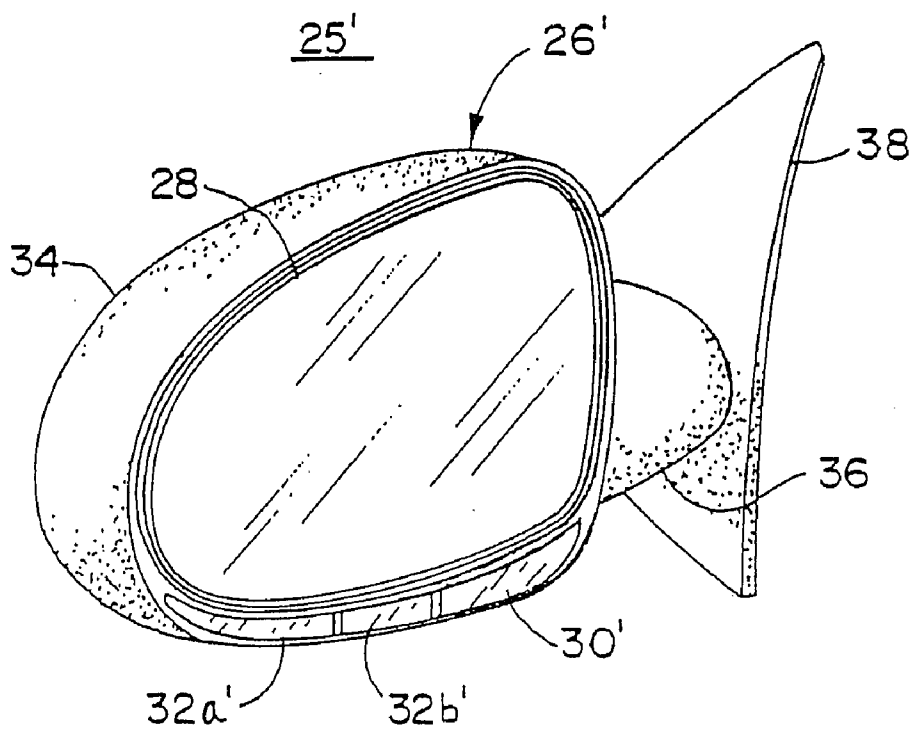

FIG. 4

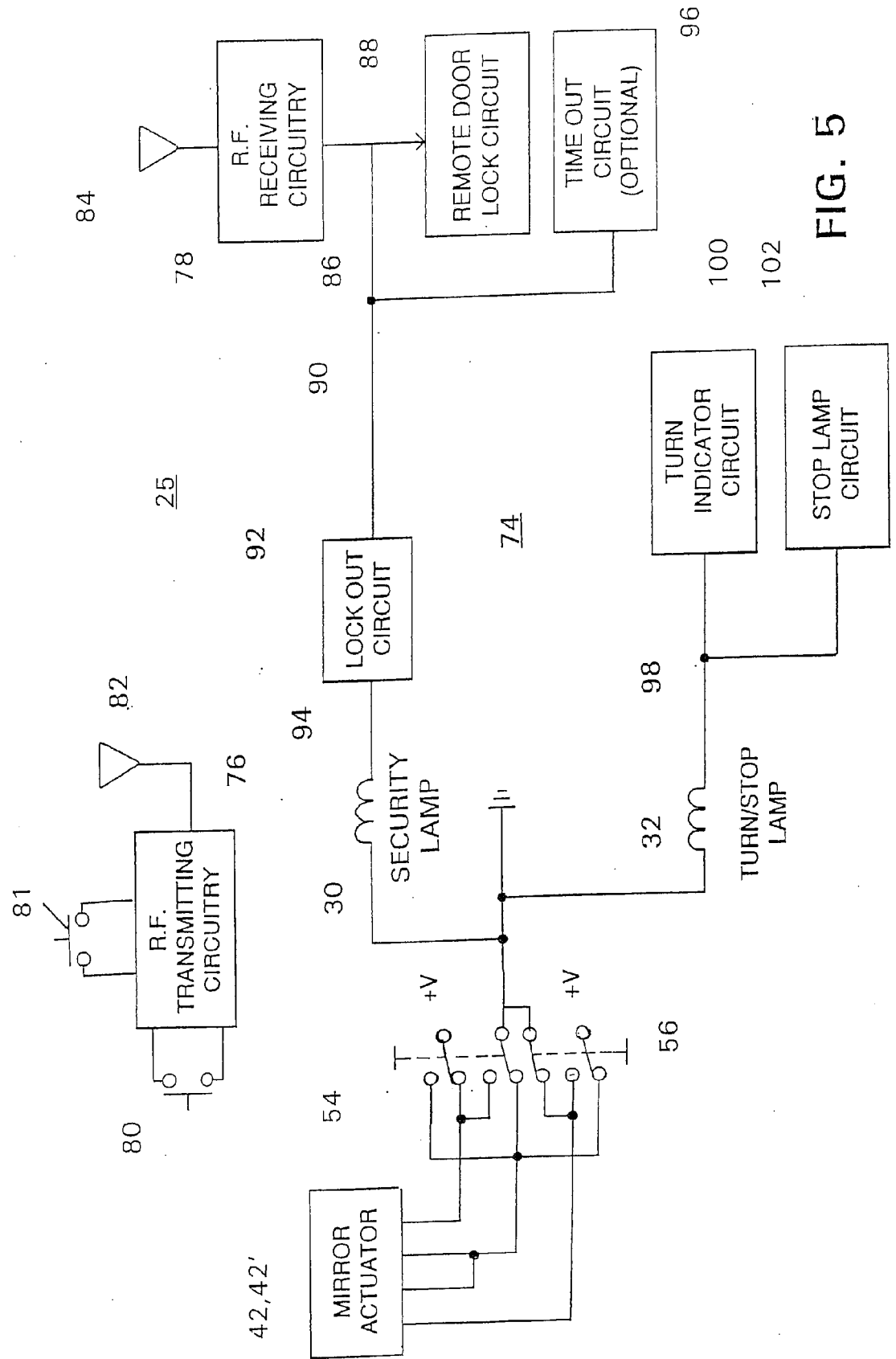

FIG. 5

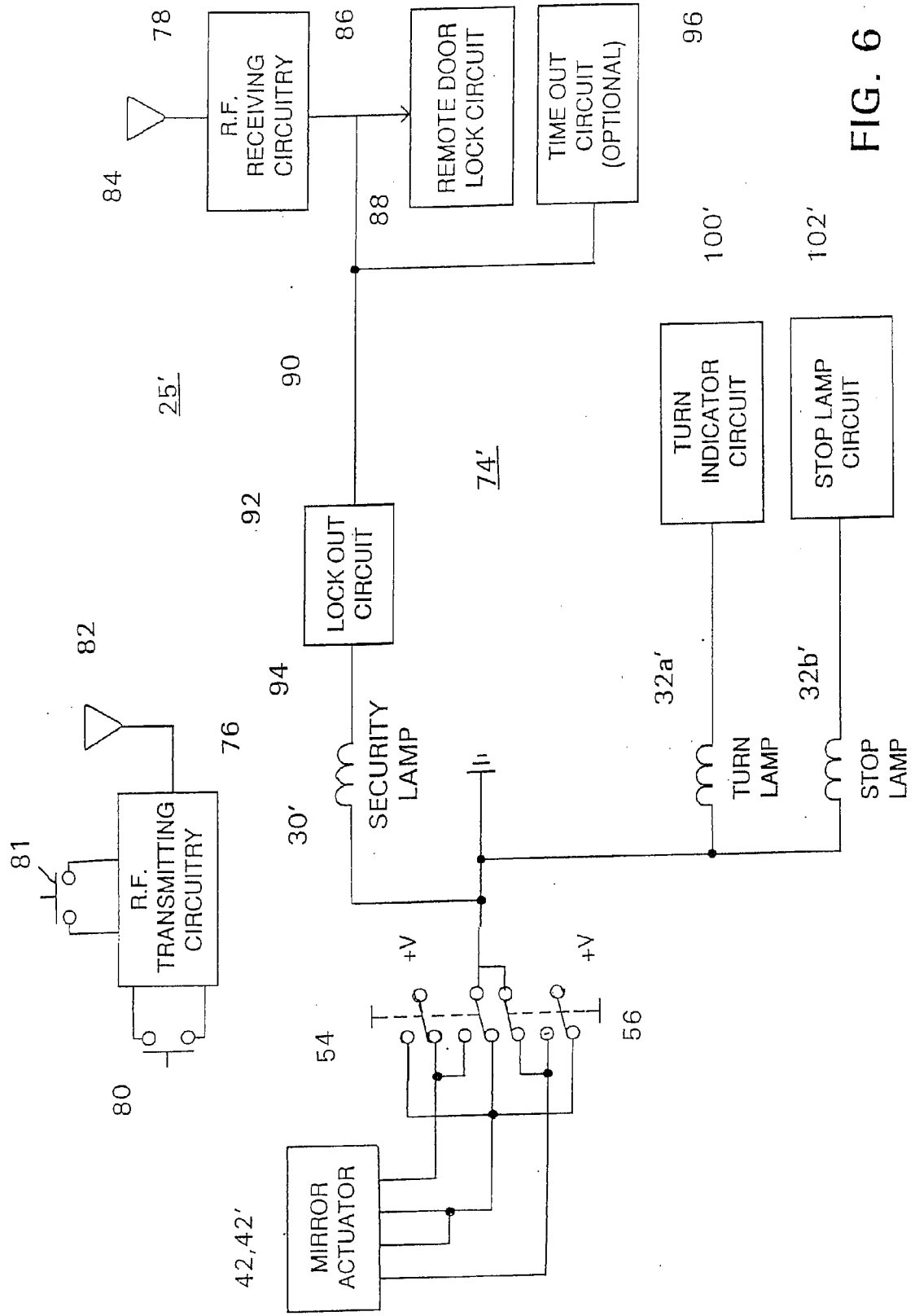

FIG. 6

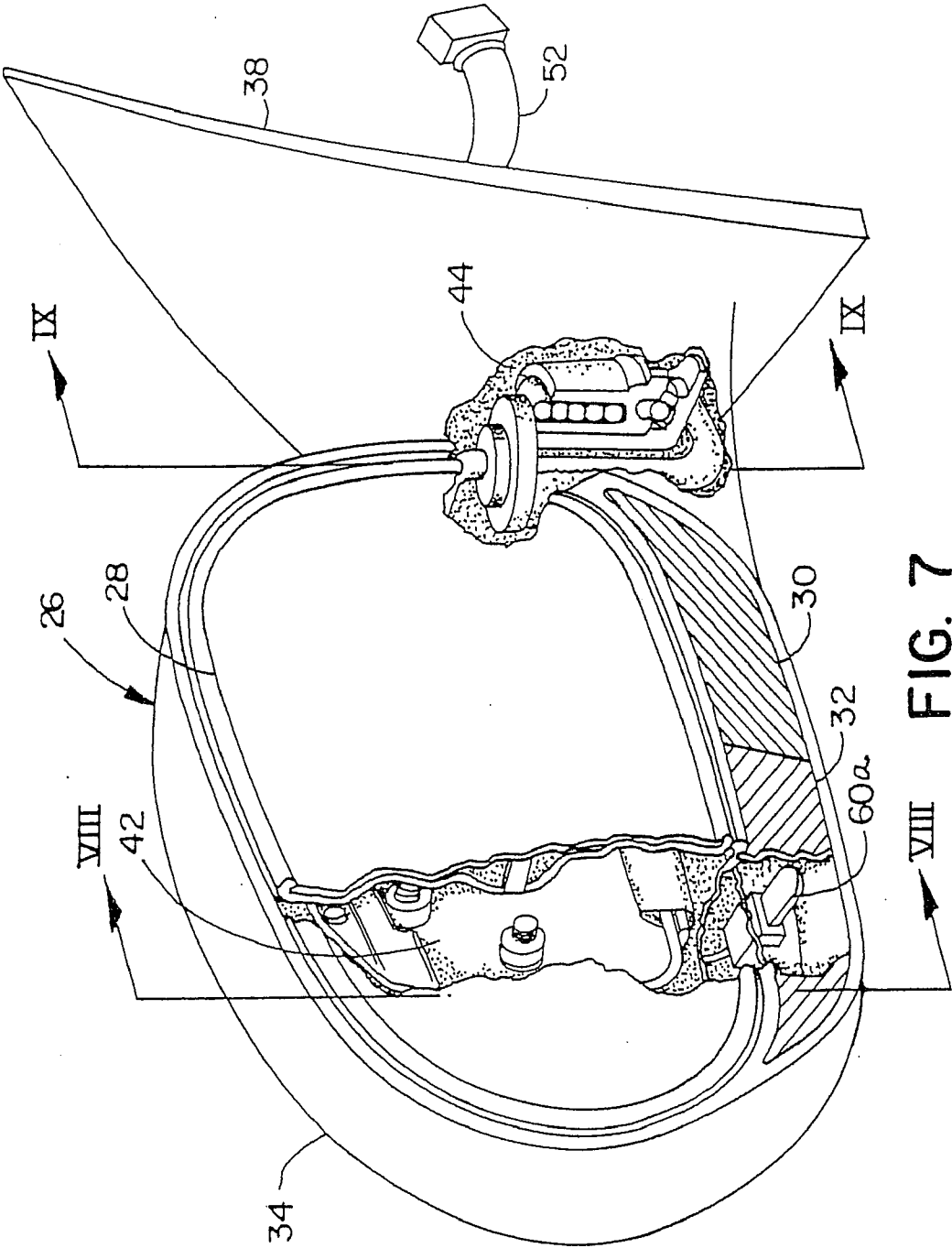

FIG. 7

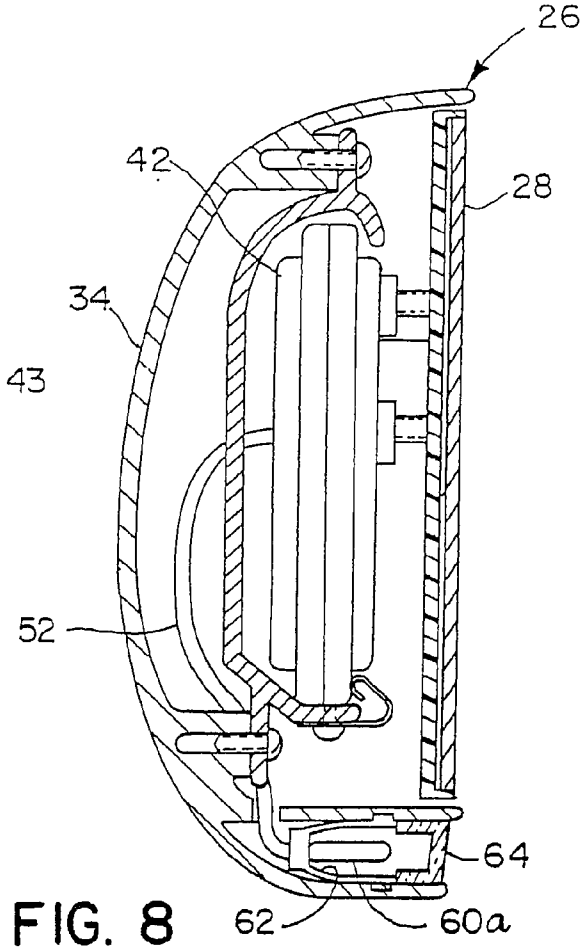

FIG. 8

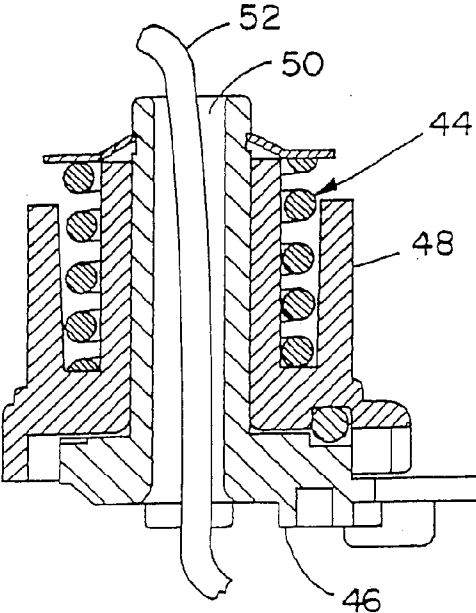

FIG. 9

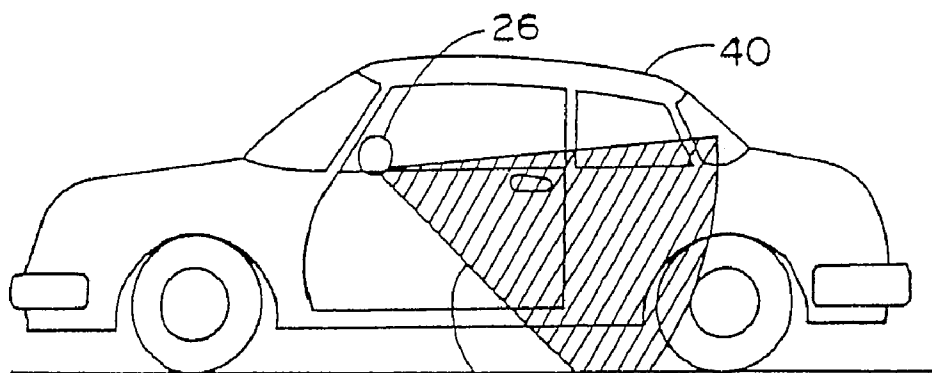

FIG. 10

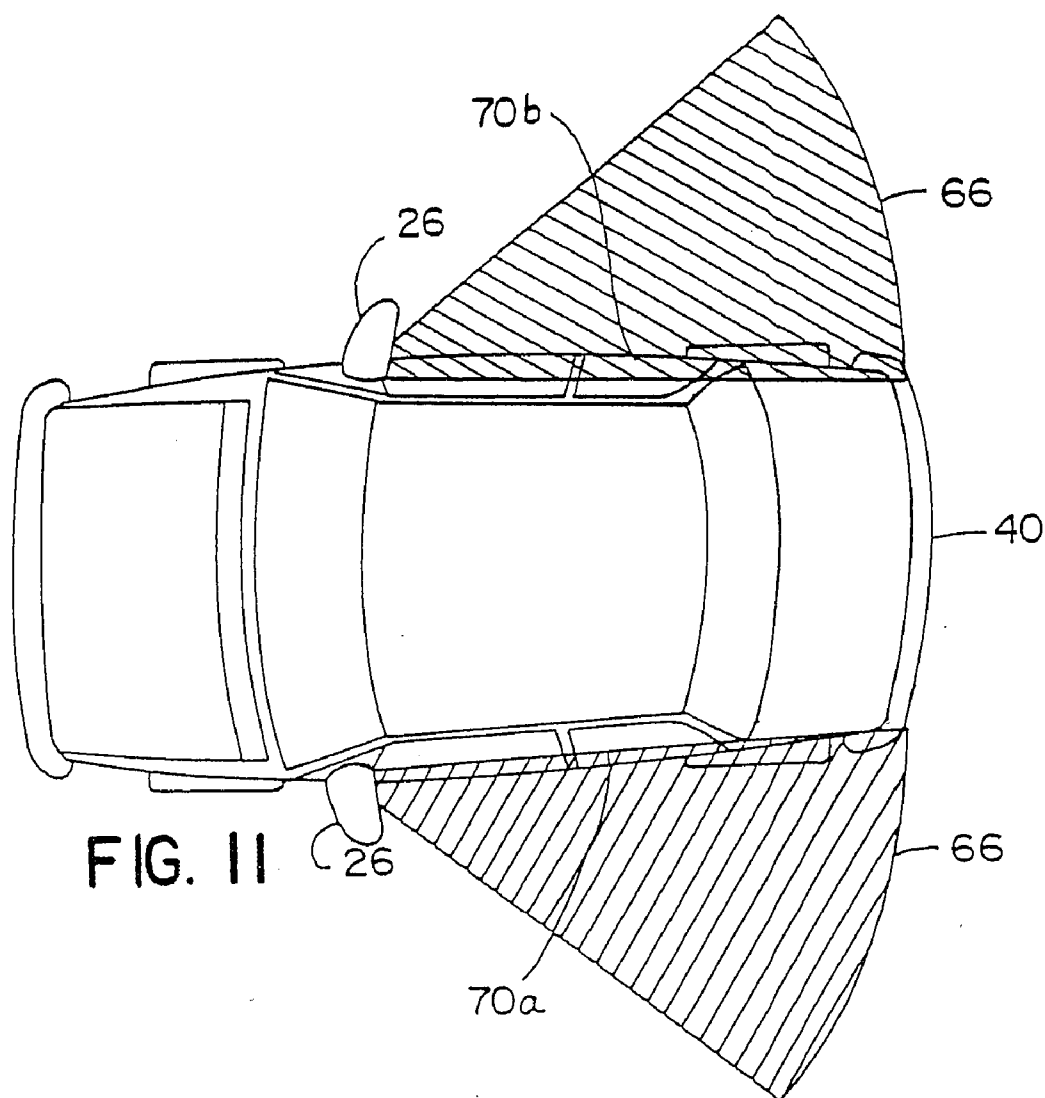

FIG. 11

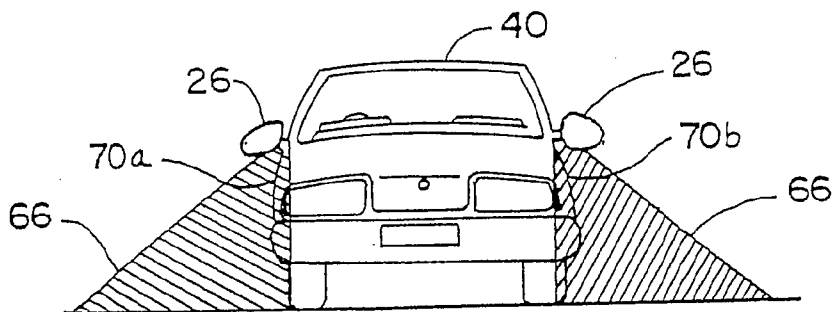

FIG. 12

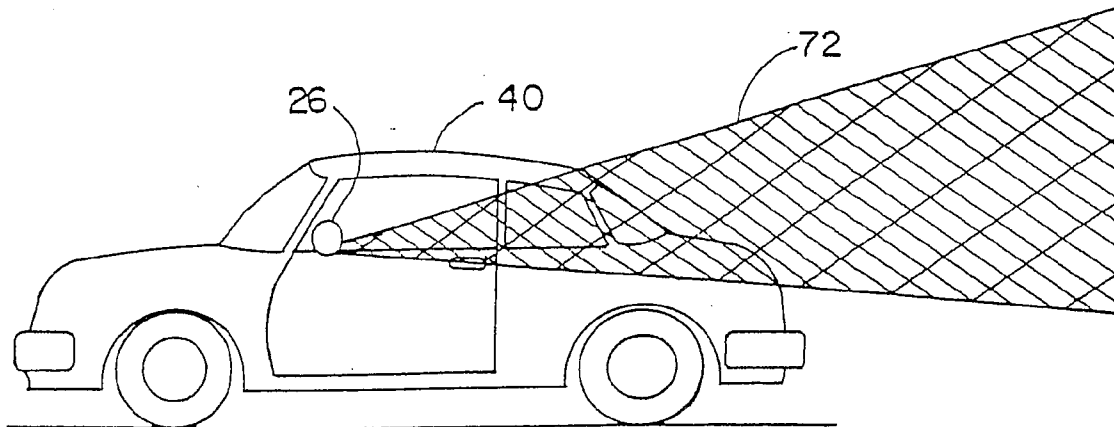
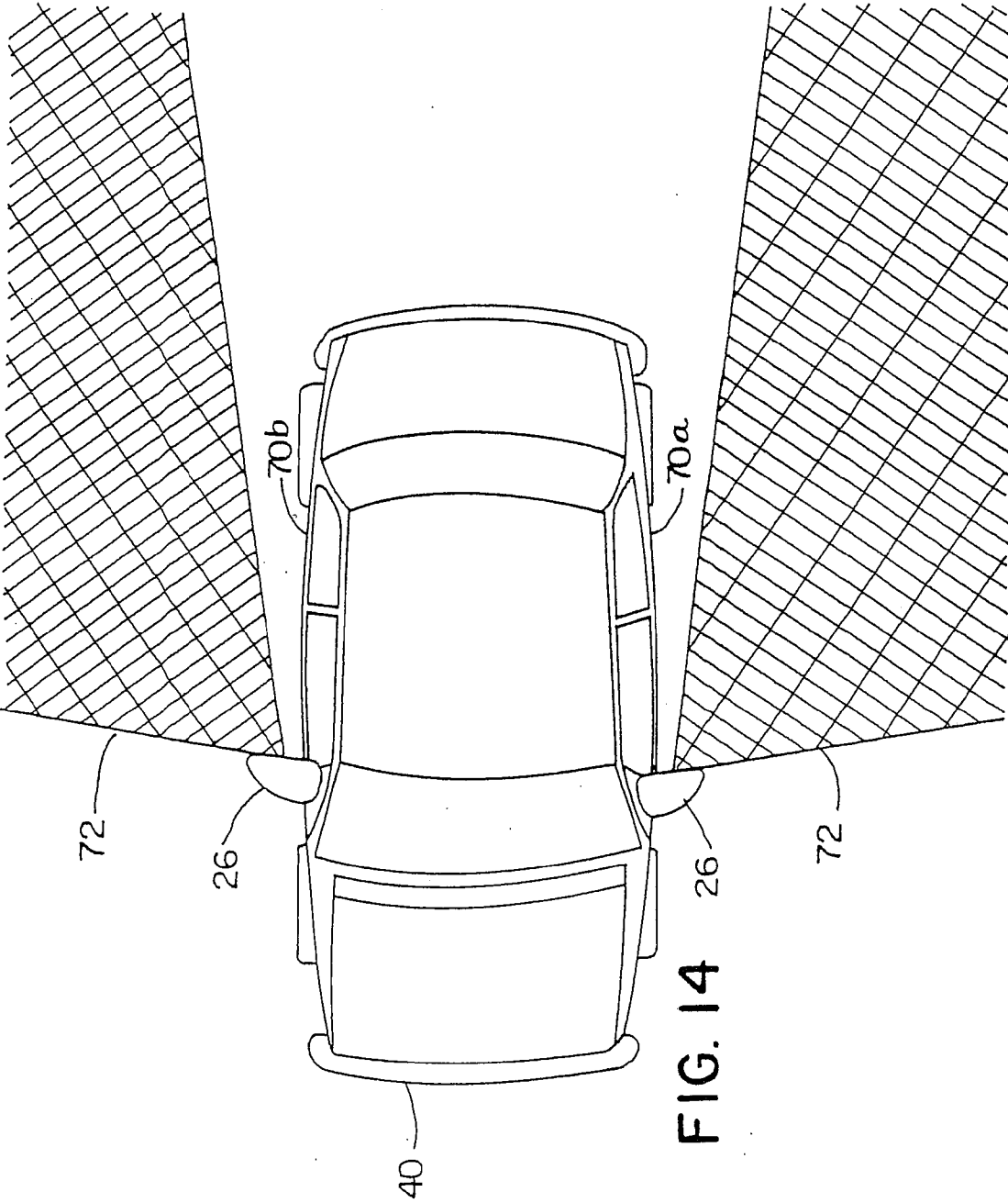

FIG. 13



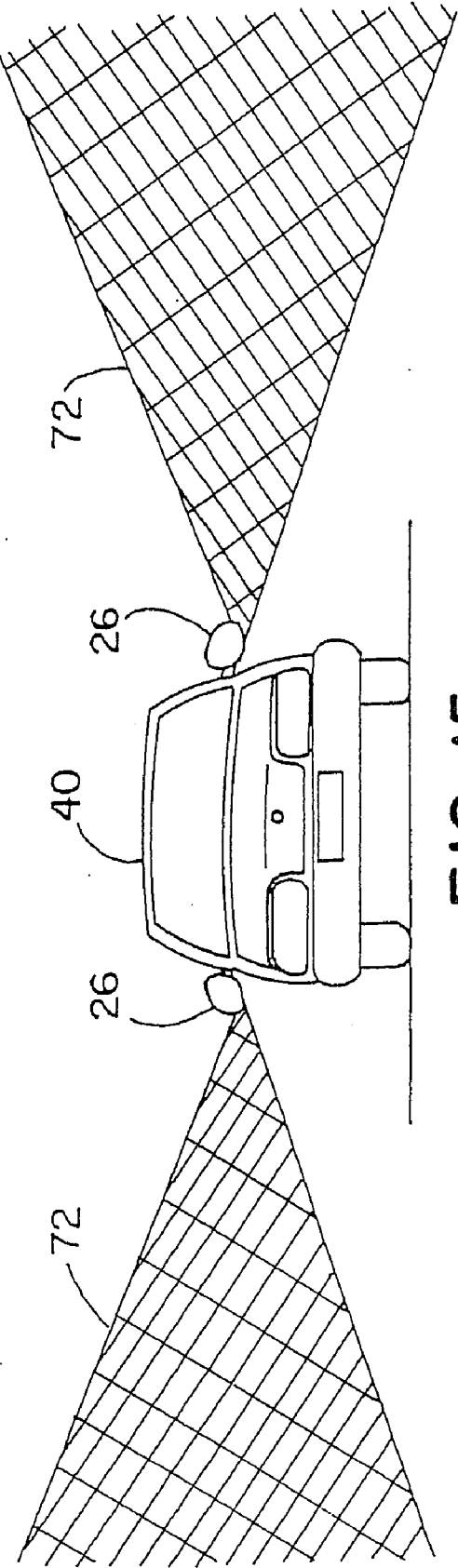

FIG. 15

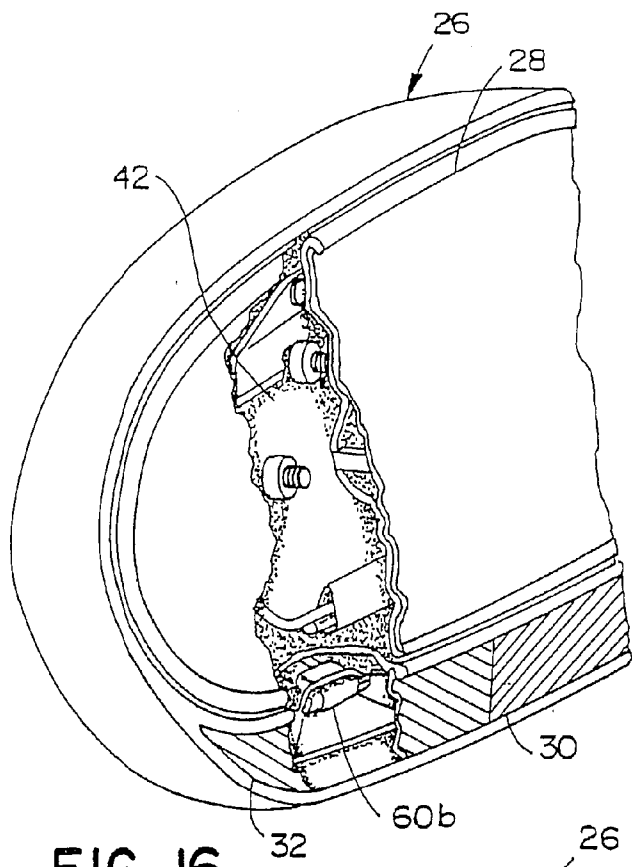

FIG. 16

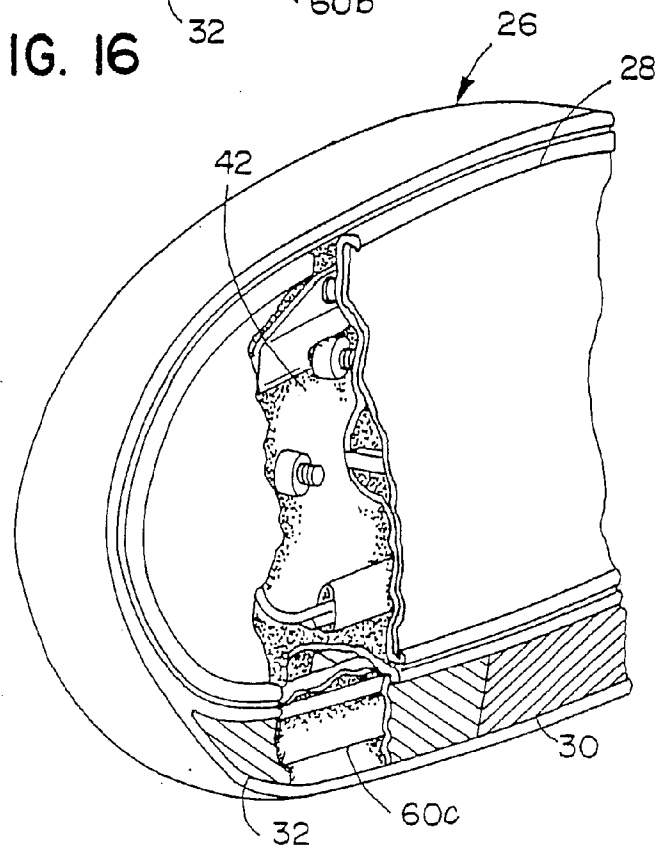

FIG. 17

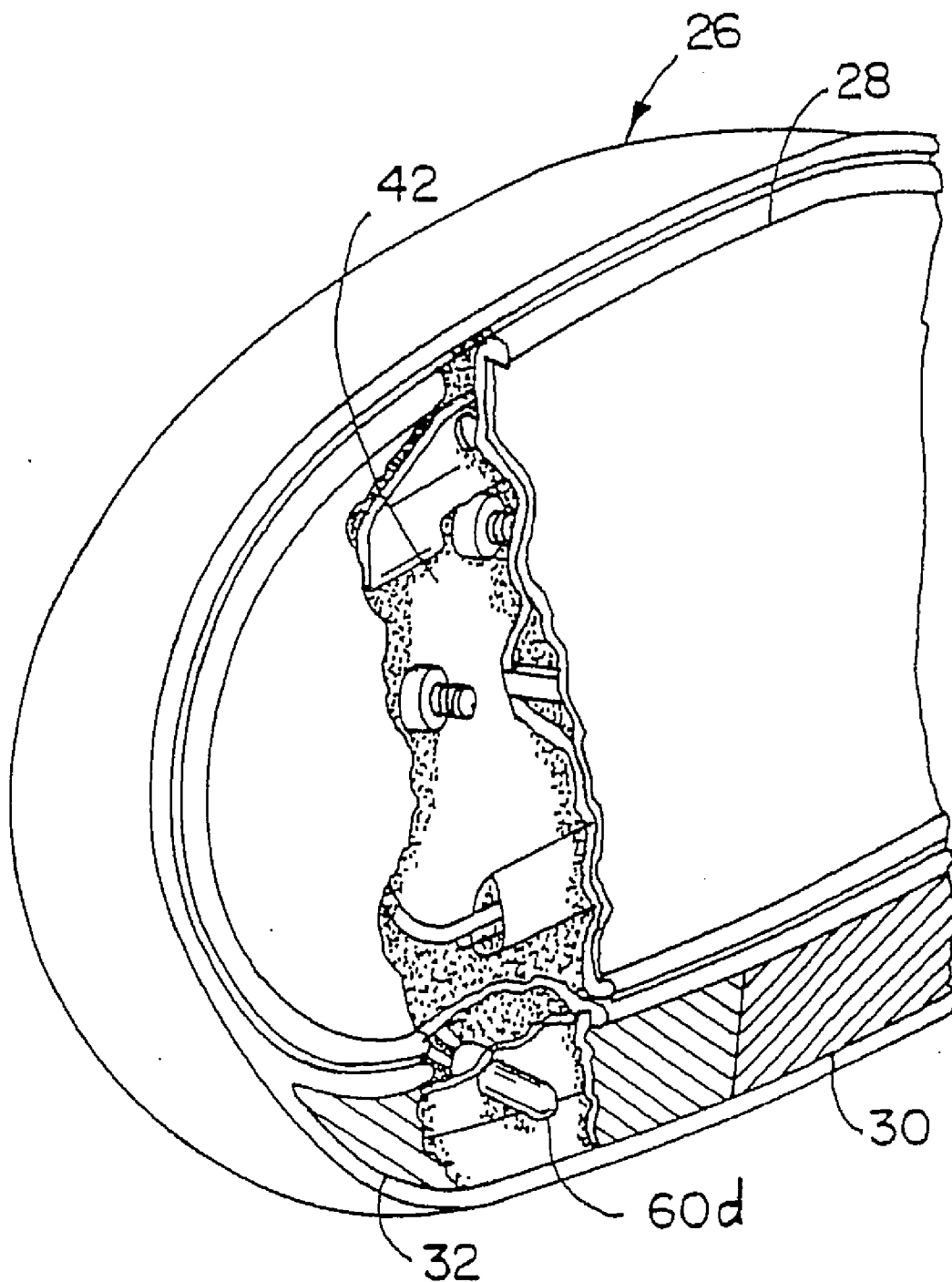

FIG. 18

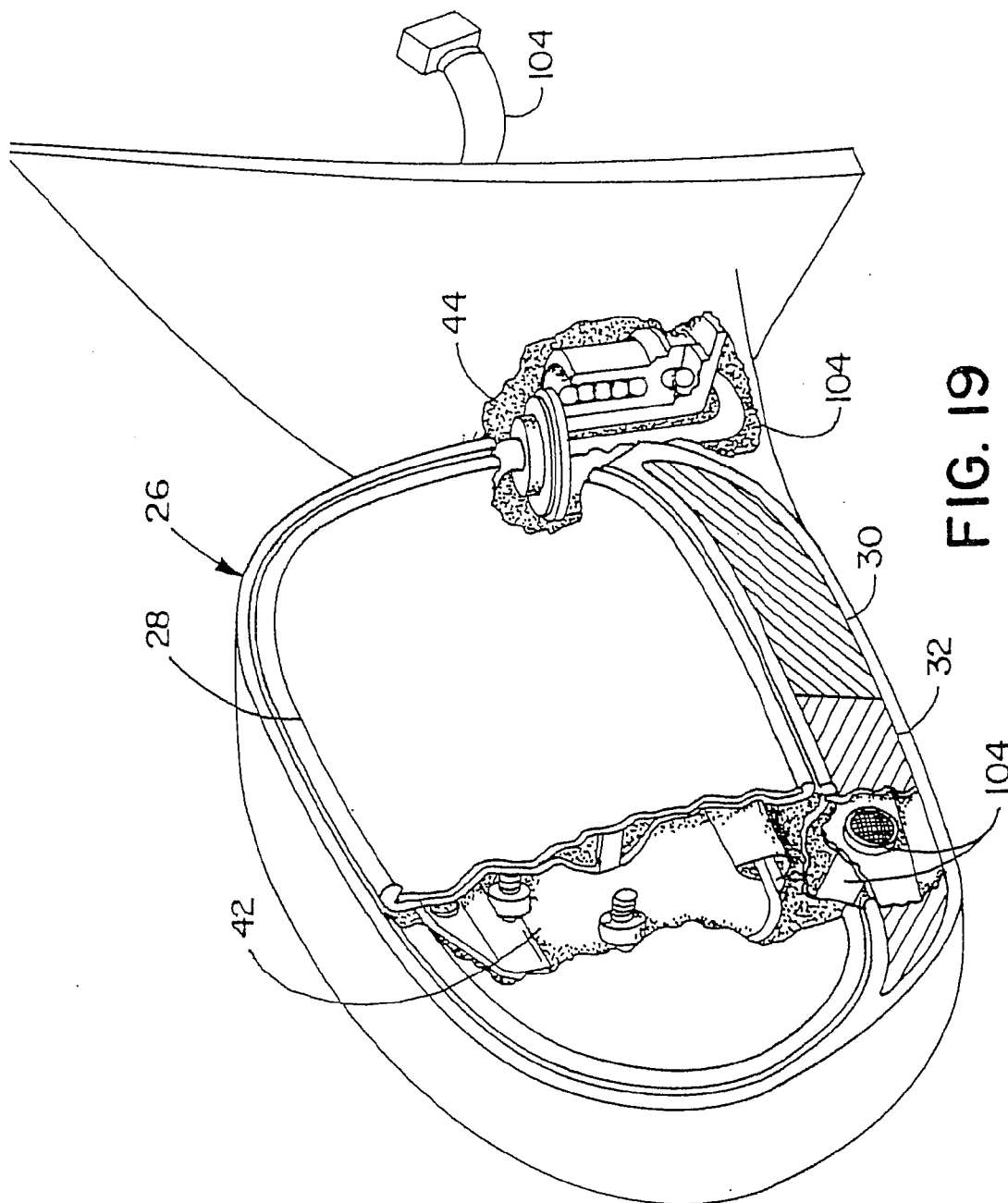

FIG. 19

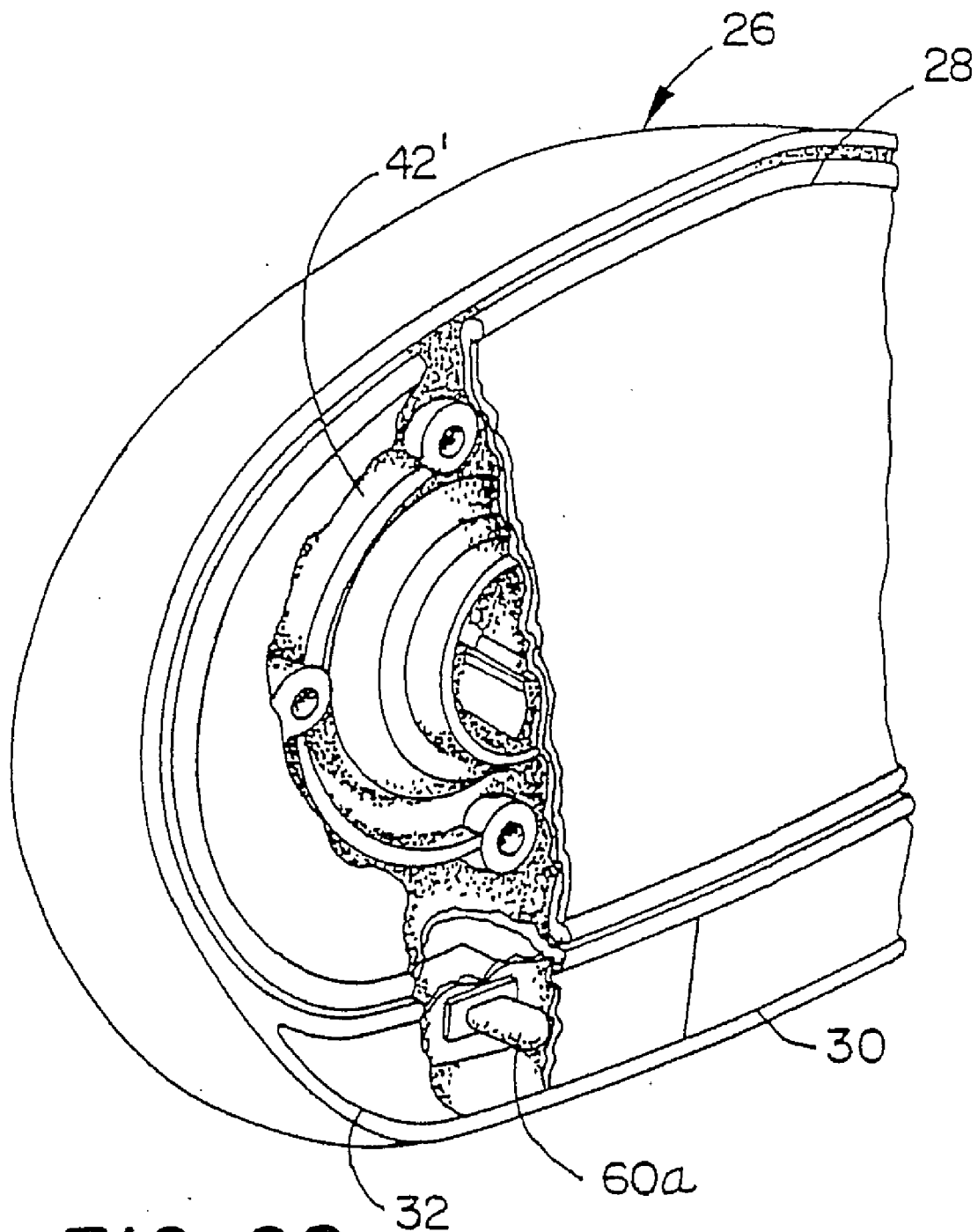
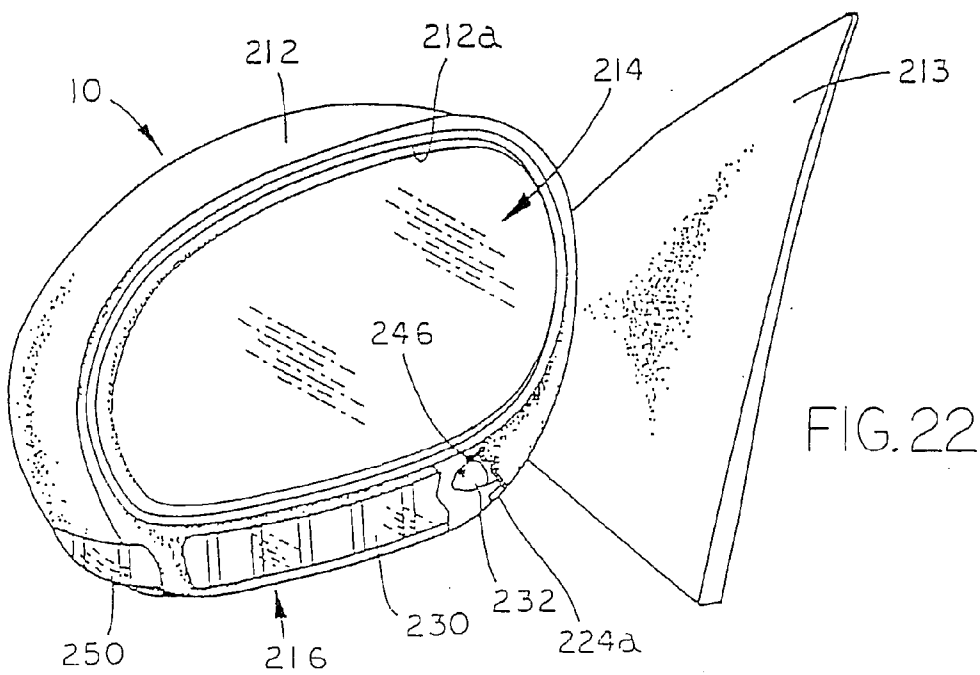
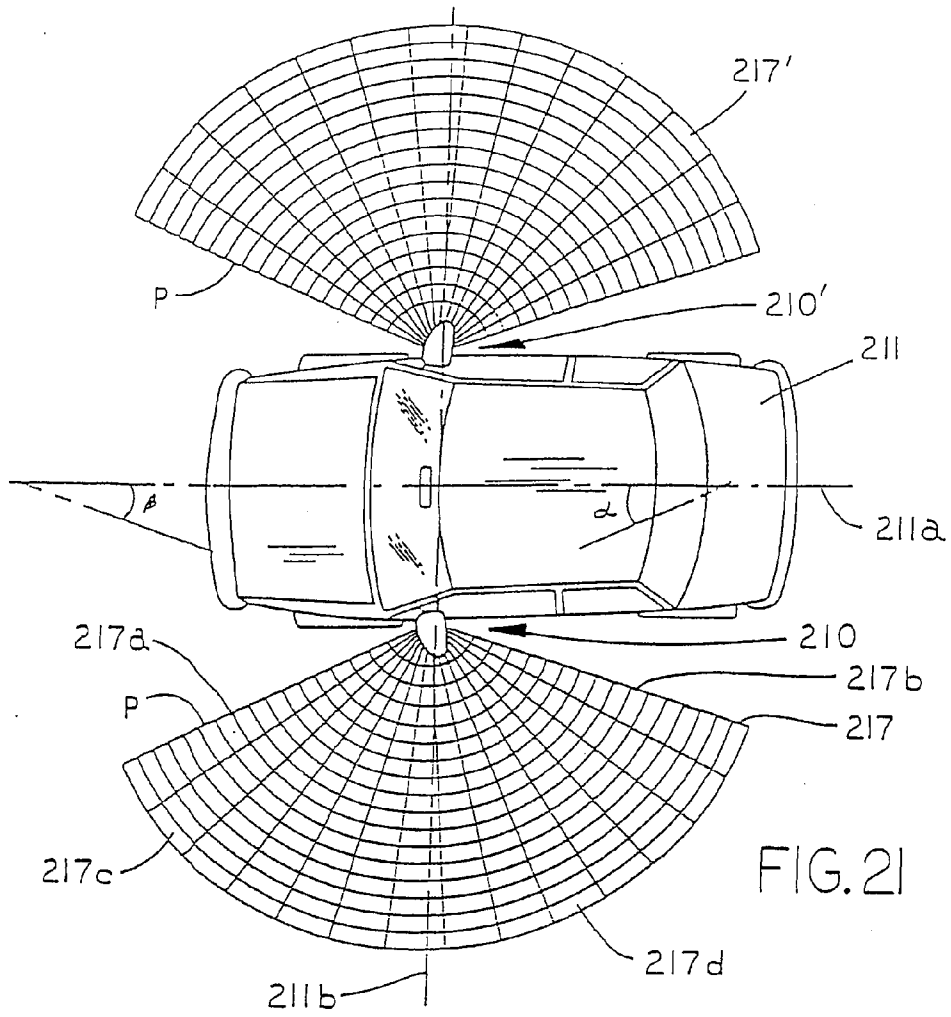
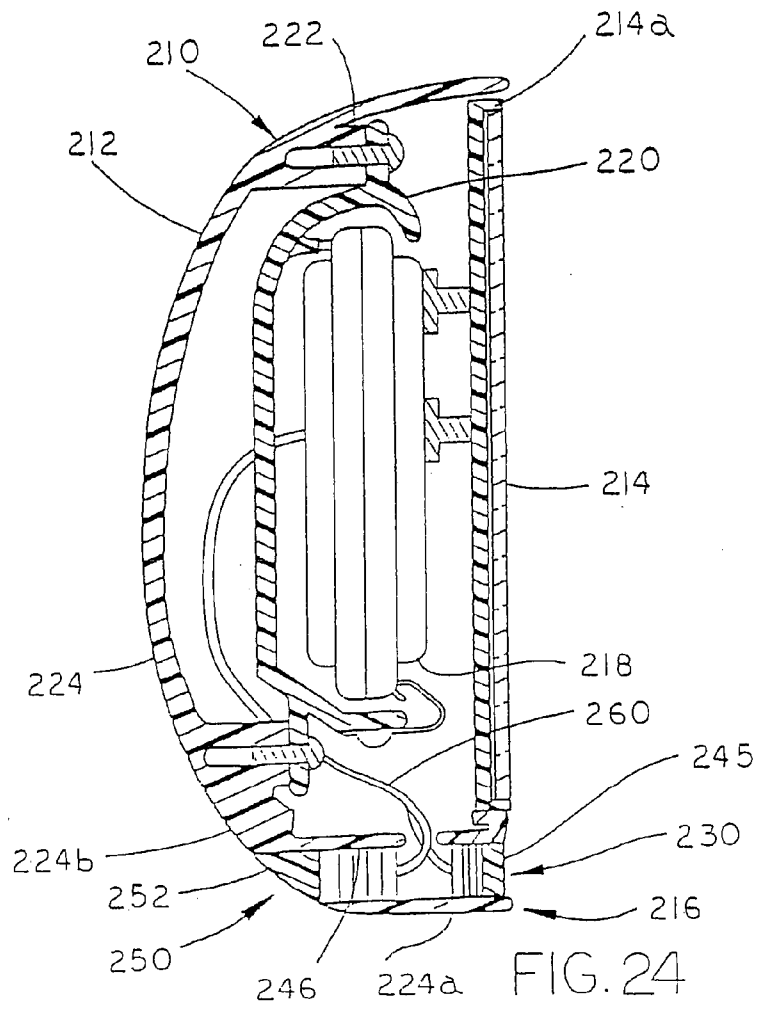
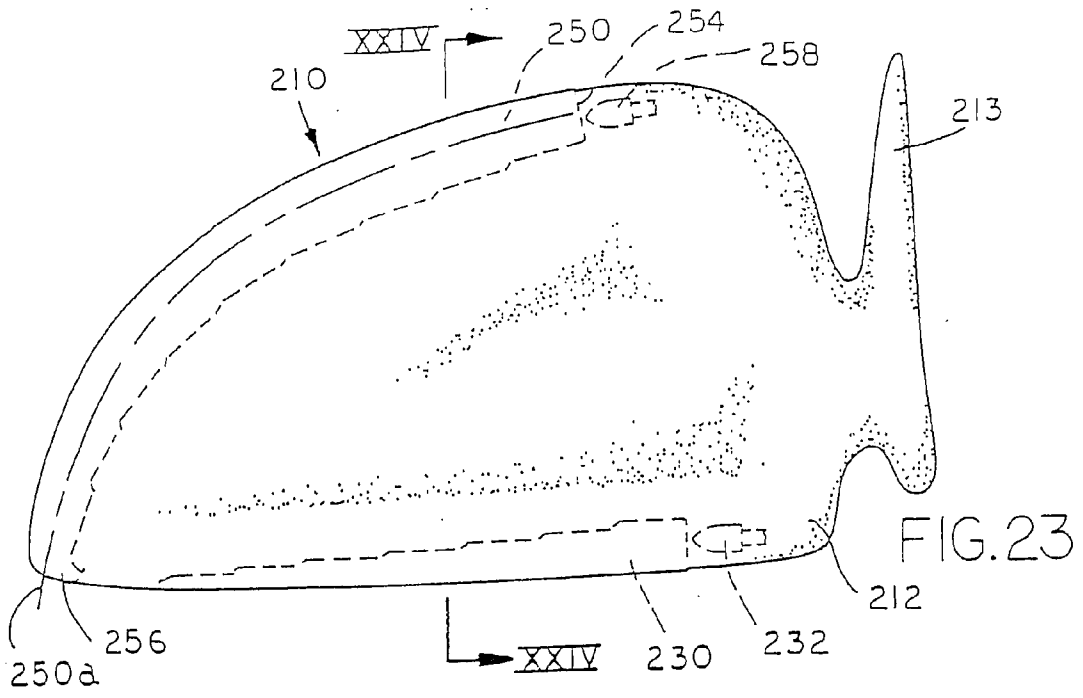
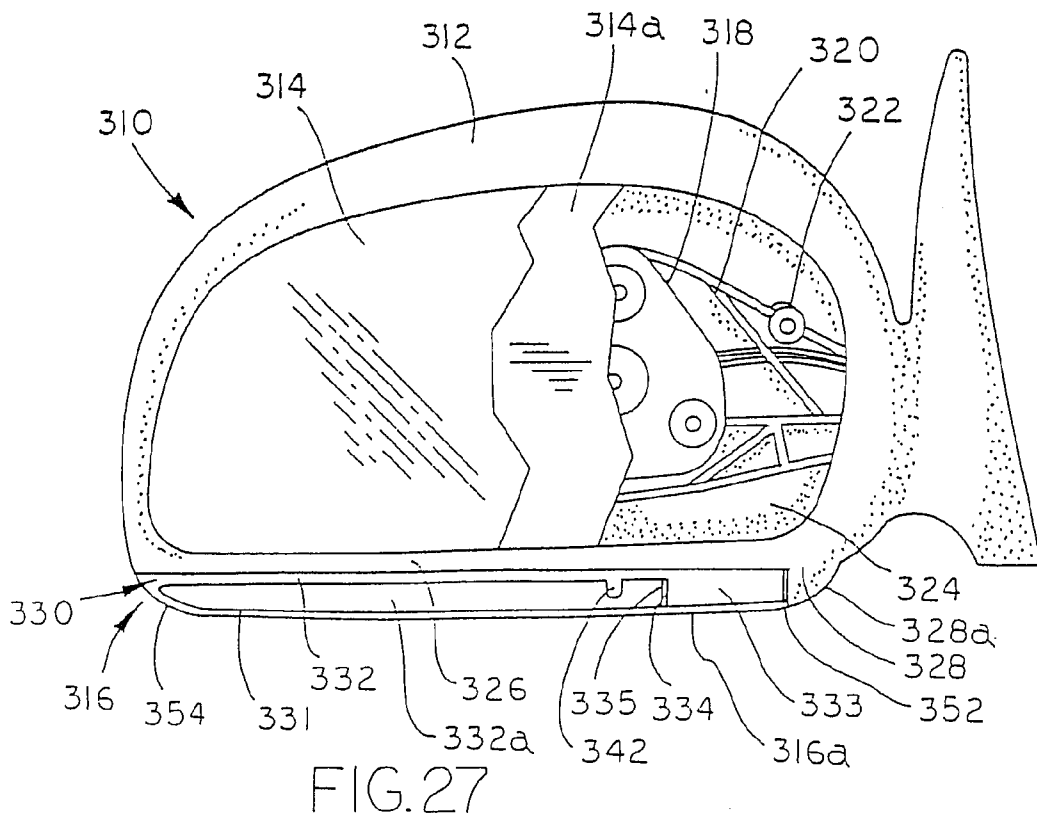
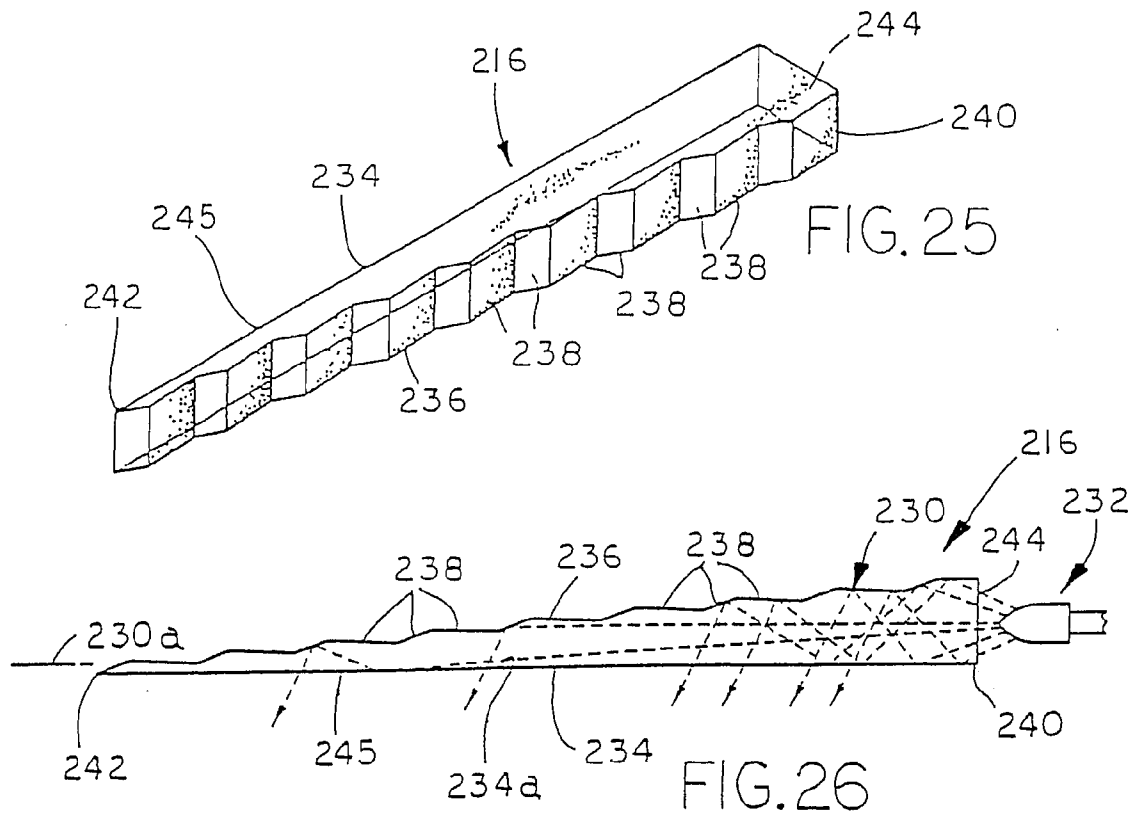

FIG. 20







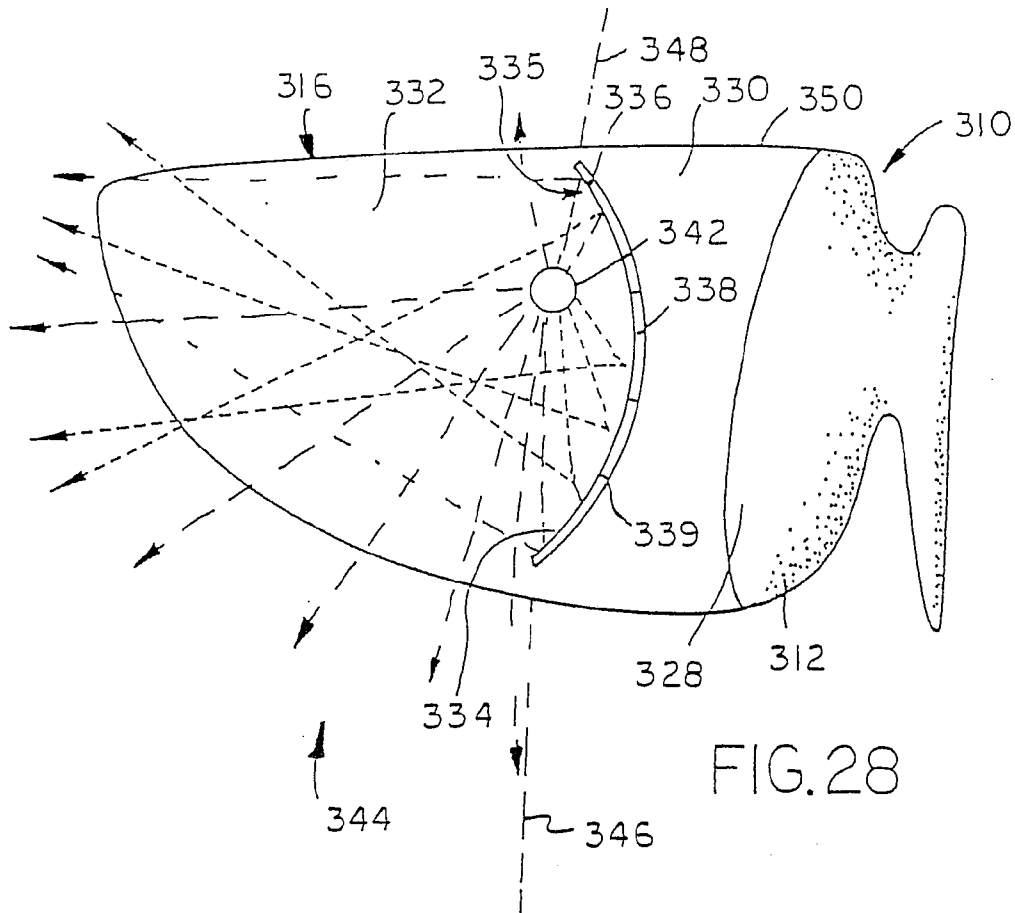

FIG. 28

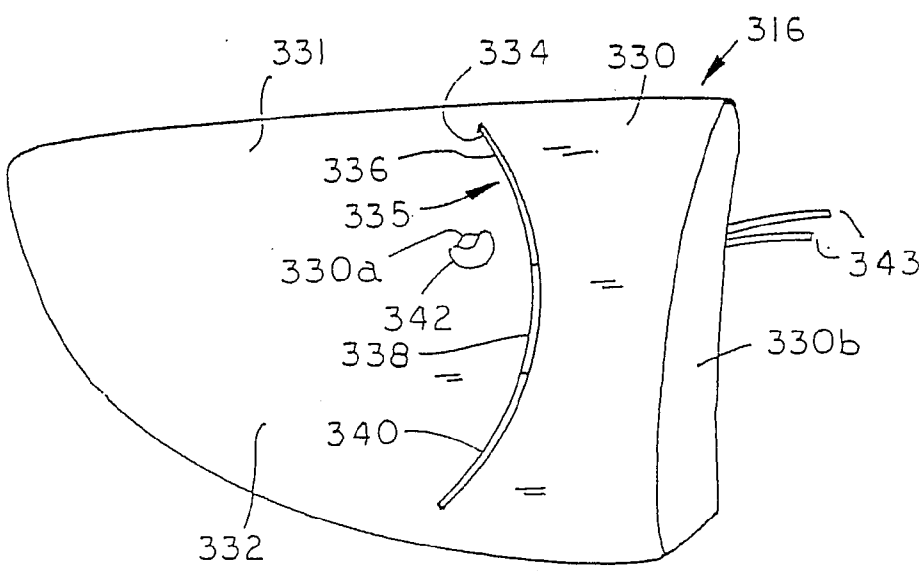
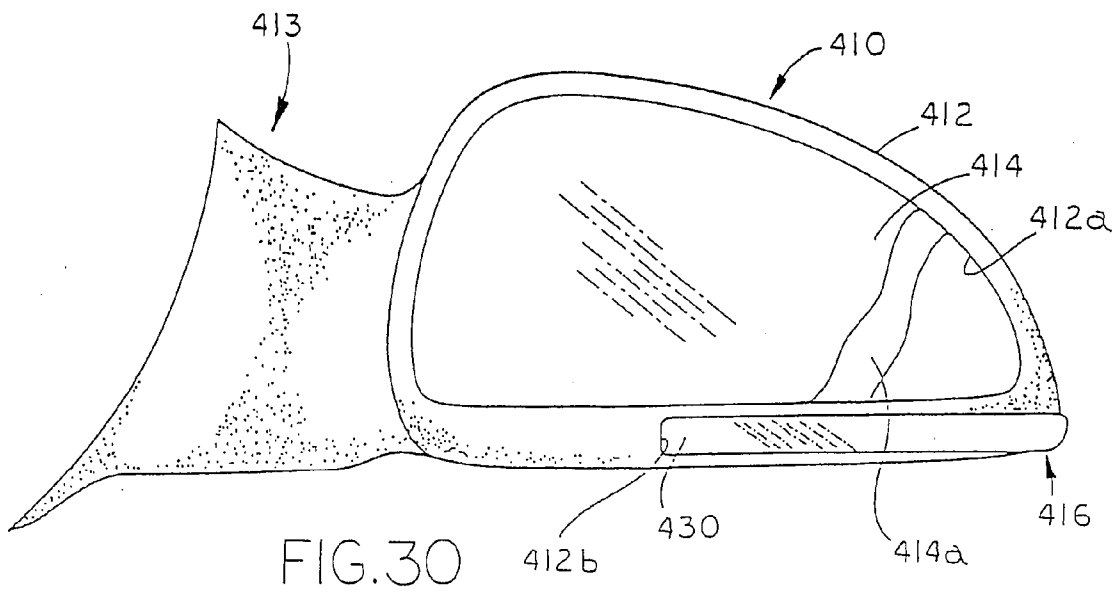
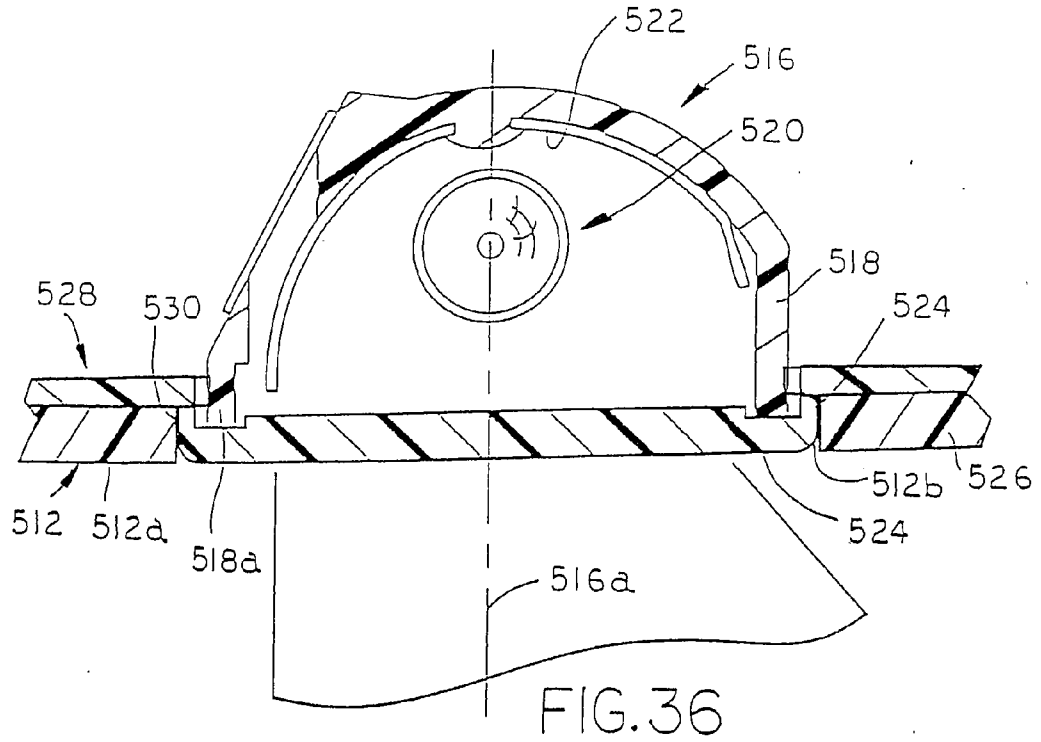
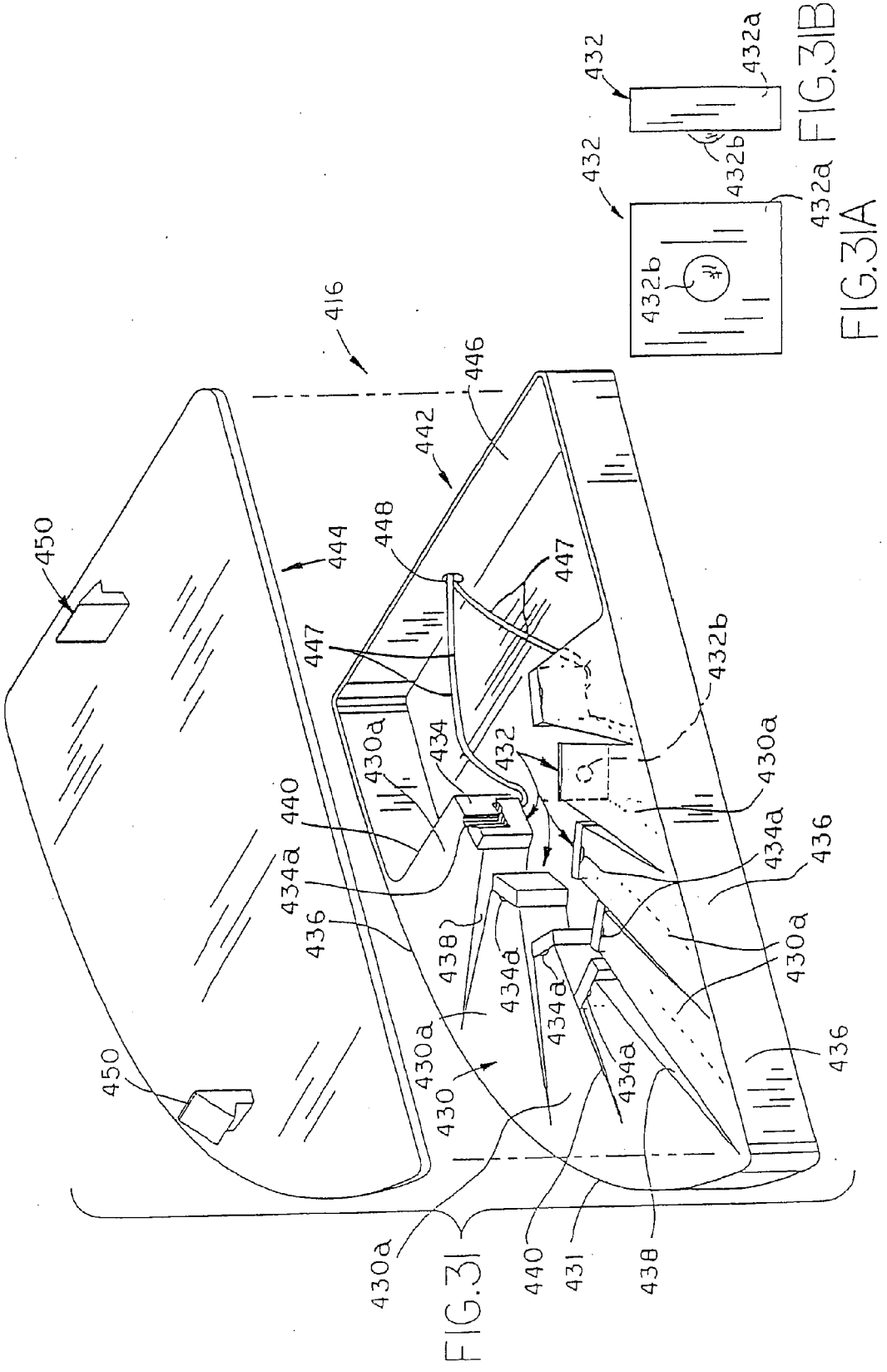

FIG. 29





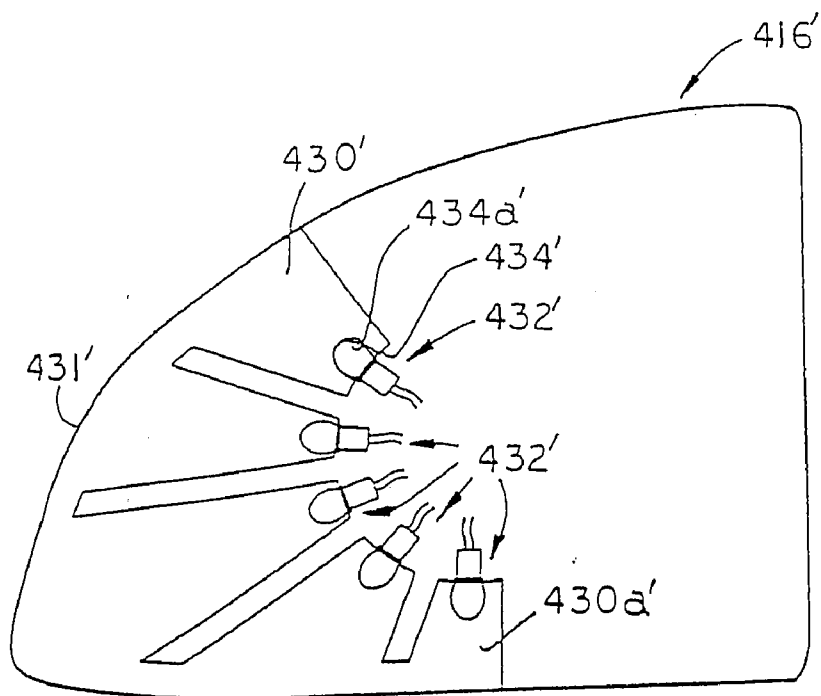

FIG. 32A

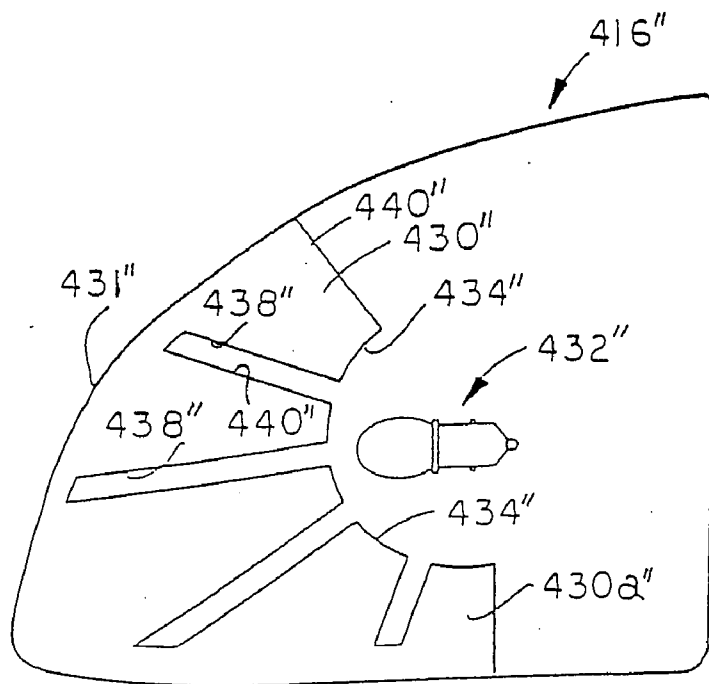
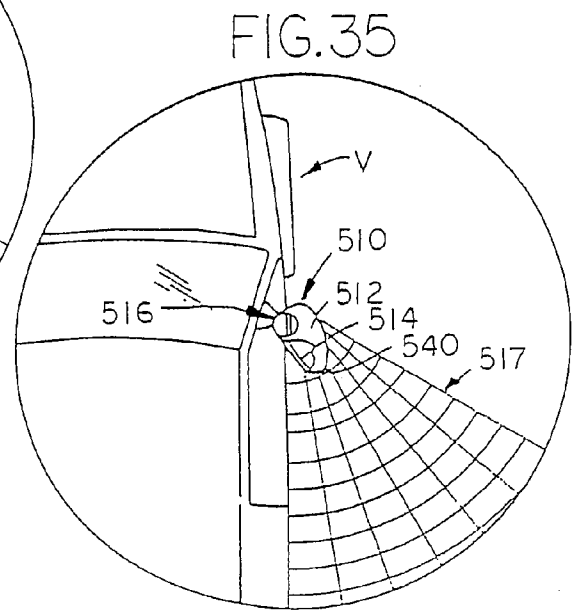
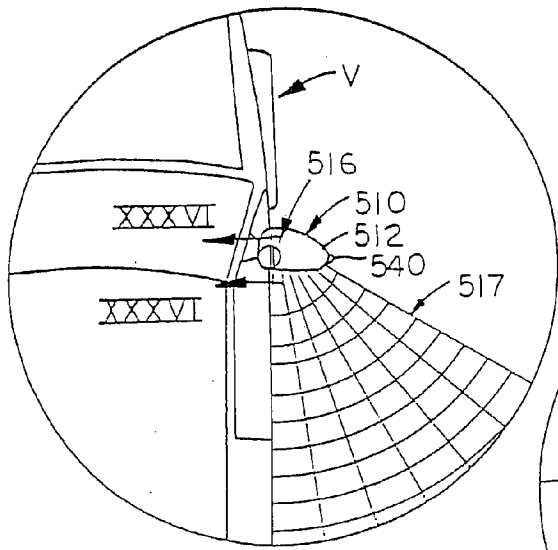
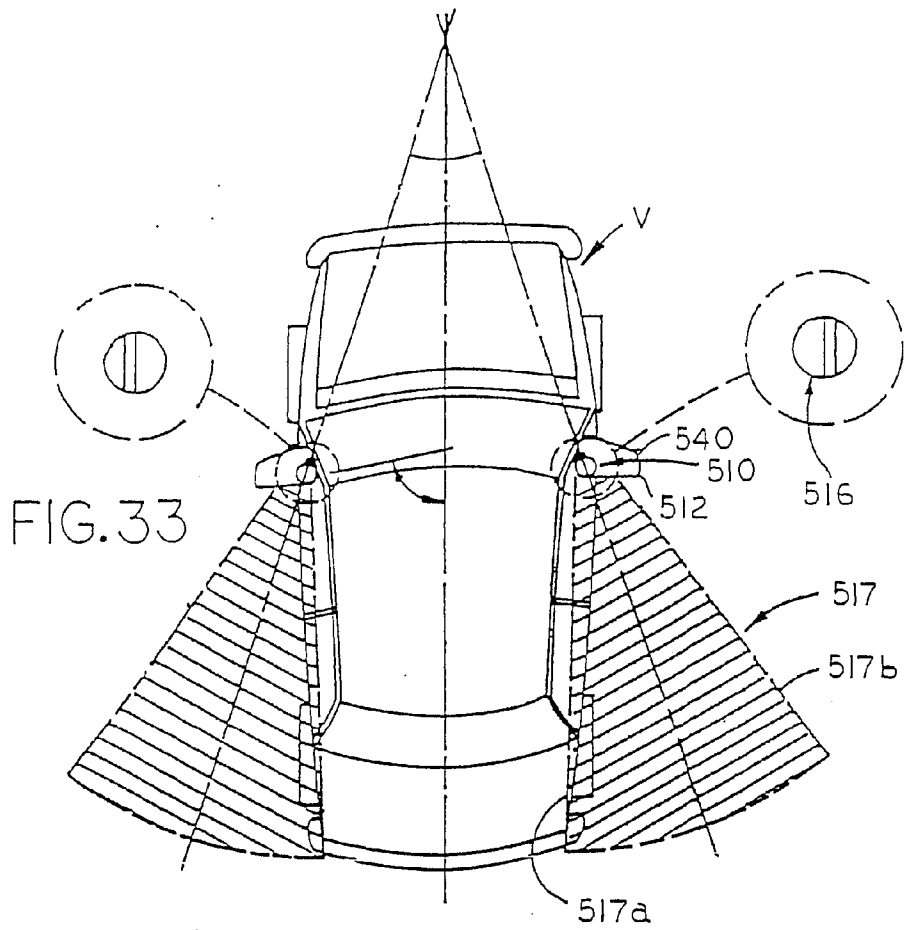
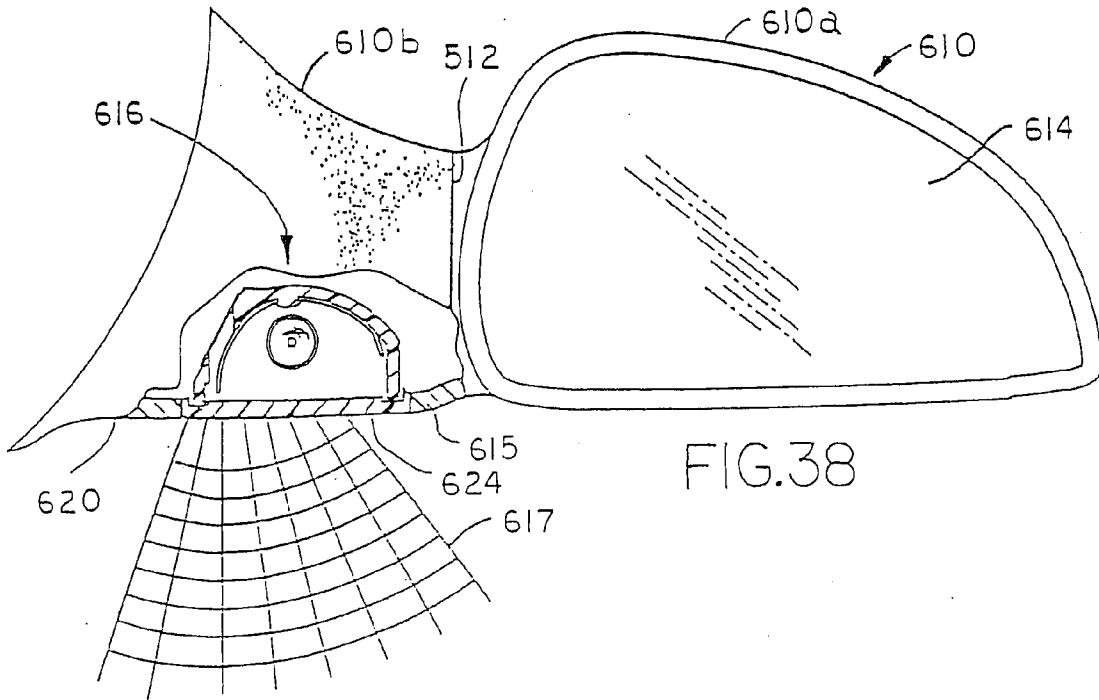
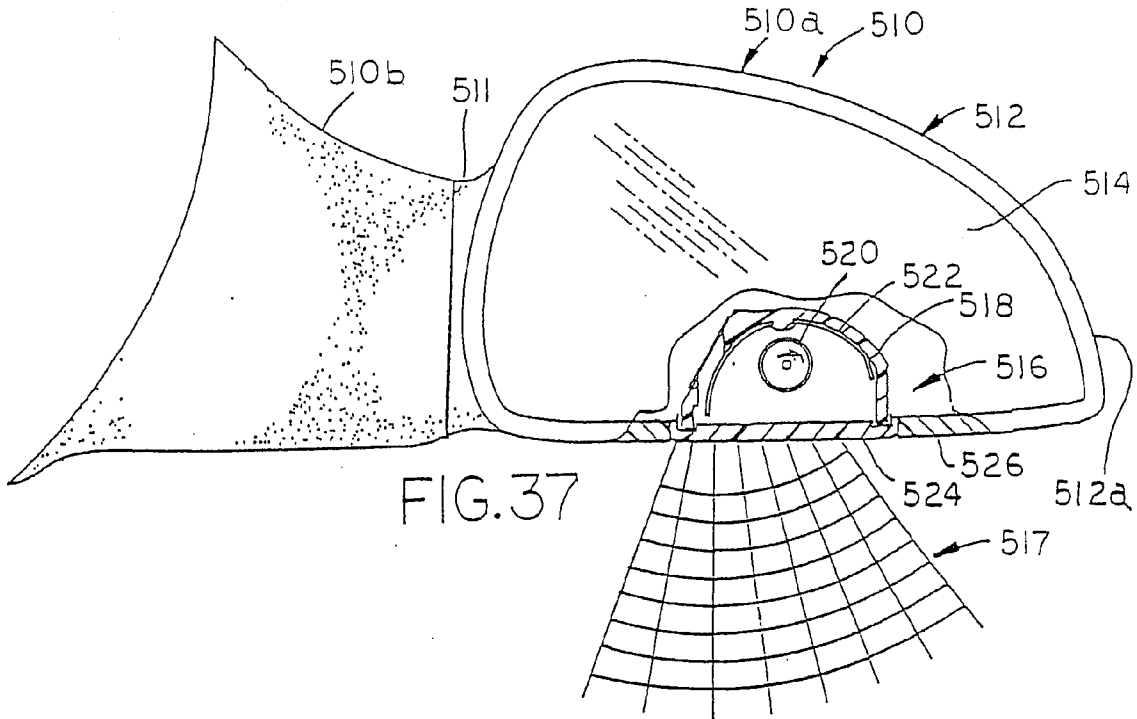

FIG. 32B





VEHICLE EXTERIOR MIRROR SYSTEM WITH SIGNAL LIGHT

CROSS REFERENCE TO RELATED APPLICATIONS

[0001] The present application is a division of U.S. patent application Ser. No. 11/649,143, filed Jan. 3, 2007, now U.S. Pat. No. 7,377,675, which is a continuation of U.S. patent application Ser. No. 10/407,555, filed Apr. 4, 2003, now U.S. Pat. No. 7,168,830, which is divisional application of U.S. patent application Ser. No. 09/690,048, filed Oct. 16, 2000, now U.S. Pat. No. 6,568,839, which is a divisional of U.S. patent application Ser. No. 09/102,414, filed on Jun. 22, 1998, now U.S. Pat. No. 6,176,602, which is a continuation-in-part of patent application Ser. No. 08/934,490, filed Sep. 19, 1997, now U.S. Pat. No. 5,863,116, which is a continuation of patent application Ser. No. 08/607,285, filed Feb. 26, 1996, now U.S. Pat. No. 5,669,705, which is a continuation of patent application Ser. No. 08/333,412, filed Nov. 2, 1994, now U.S. Pat. No. 5,497,305, which is a continuation of patent application Ser. No. 08/011,947, filed Feb. 1, 1993, now U.S. Pat. No. 5,371,659, all of which are incorporated herein by reference in their entireties. The grandparent application, namely Ser. No. 09/102,414, filed Jun. 22, 1998, is additionally a continuation-in-part of patent application Ser. No. 08/687,628, filed Jul. 26, 1996, now U.S. Pat. No. 5,823,654, which is a continuation-in-part of patent application Ser. No. 08/607,284, filed Feb. 26, 1996, now U.S. Pat. No. 5,669,704, which is a continuation of patent application Ser. No. 08/426,591, filed Apr. 21, 1995, now U.S. Pat. No. 5,497,306, which is a continuation-in-part of patent application Ser. No. 08/333,412, filed Nov. 2, 1994, now U.S. Pat. No. 5,497,305, which is a continuation of patent application Ser. No. 08/011,947, filed Feb. 1, 1993, now U.S. Pat. No. 5,371,659, which are all incorporated herein by reference in their entireties.

TECHNICAL FIELD AND BACKGROUND OF THE INVENTION

[0002] This invention relates generally to security systems for vehicles and, more particularly, to remotely actuated, personal safety lighting systems. The invention is particularly adapted to incorporation in the exterior mirrors of a vehicle. [0003] Personal security in and around vehicles has become an important concern. In particular, an increasing number of assaults and robberies are committed in parking lots while occupants are entering and exiting vehicles. While remote-operated, keyless entry systems have been incorporated in vehicles in order to unlock the vehicle and illuminate interior lights, such systems merely expedite entry to the vehicle and do not, per se, enhance security around the vehicle. Accordingly, a need exists for a vehicle security system to increase the security for vehicle occupants while entering and exiting the vehicle. Any such system would need to be aesthetically pleasing and not burdensome in use.

SUMMARY OF THE INVENTION

[0004] The present invention is intended to provide a personal safety feature for a vehicle in the form of a floodlight adapted to projecting light generally downwardly on an area adjacent a portion of the vehicle in order to create a lighted security zone in the area. Advantageously, the floodlight is preferably positioned in the housing of an exterior mirror having a reflective element also positioned in the housing.

According to an aspect of the invention, an actuator is provided for the floodlight including a base unit in the vehicle and a remote transmitter. The base unit is responsive to a signal from the remote transmitter in order to actuate the floodlight. This allows the vehicle operator to actuate the floodlight from a distance in order to establish the security zone prior to approaching the vehicle.

[0005] According to another aspect of the invention, an actuator for the floodlight includes a lockout device in order to prevent actuation of the floodlight during operation of the vehicle. According to yet a further aspect of the invention, a signal light that is adapted to projecting light generally rearwardly of the vehicle is included in the exterior mirror housing. An actuator for the warning light is connected with the stoplight circuit, turn signal circuit, or both the stoplight and turn signal circuit, of the vehicle in order to actuate the warning light when either the stoplight or turn signal is being actuated.

[0006] According to yet another aspect of the invention, the floodlight is adapted to projecting a pattern of light from the housing on an area adjacent a portion of the vehicle that extends laterally onto the vehicle and downwardly and rearwardly of the vehicle. In this manner, a security zone is established from the vehicle door to the rear of the vehicle. The signal light is adapted to projecting a pattern of light extending laterally away from the vehicle and rearwardly of the vehicle. In this manner, the pattern generated by the signal light cannot be substantially observed by a driver of the vehicle. However, the pattern generated by the signal light may be observed by a driver of another vehicle passing the vehicle equipped according to the invention.

[0007] The floodlight and signal lights may be generated by a light emitting diode positioned in the housing, a vacuum fluorescent lamp positioned in the housing, an incandescent lamp positioned in the housing or a light source in the vehicle and a light pipe between the light source and the mirror housing.

[0008] By providing a lighted security zone adjacent the vehicle, users can observe suspicious activity around the vehicle. The pattern of light generated by a security light according to the invention establishes a security zone around, and even under, the vehicle in the important area where the users enter and exit the vehicle. The provision for remote actuation of the security light provides a deterrent to ward off persons lurking around the protected vehicle while the users are still at a safe distance from the vehicle. The provision for a lockout circuit ensures that the security light will not inadvertently be actuated while the vehicle is in motion. The invention, further, conveniently combines a signal light that acts in unison with the vehicle's turn signal, brake light, or both, with the security light in an exterior mirror assembly. The signal light may be designed to be observed by other vehicles passing the equipped vehicle but not directly by the driver of the equipped vehicle.

[0009] The present invention further provides an exterior mirror system for a vehicle, which incorporates a signal light into the exterior rearview mirror assembly. The signal light provides a light pattern which preferably extends forwardly, rearwardly, and to the side of the vehicle in order to provide advance warning to approaching vehicles, or to a vehicle that is in the vehicle's blind spot, that the driver of the vehicle intends to make a turn or lane change, with the light pattern preferably restricted from direct observation by a driver of the vehicle. Additionally, the present invention provides a "pow-

erfold" exterior mirror system which includes a security light that projects a pattern of light adjacent side of the vehicle and fans the light outwardly from the vehicle to provide a security zone, which is optionally adapted to maintain the position of the pattern of light even when the exterior rearview mirror assembly is moved between its normal extended operating position to a folded position. It is quite common in vehicles in many European countries to have electrically retractable or "powerfold" mirrors.

[0010] According to one form of the invention, an exterior mirror system for a vehicle includes an exterior mirror assembly, which includes a reflective element, a housing for the reflective element, and a positioning device for adjusting the position of the reflective element in the housing. The mirror assembly is adapted to mount to the vehicle and includes at least one signal light. The signal light includes a light source and a light conduiting member. The light conduiting member is oriented for facing at least rearward of the vehicle and is adapted to project a pattern of light from the housing which extends at least rearwardly of and laterally from the vehicle and to restrict the light from extending into the vehicles so that a driver seated in the vehicle does not directly observe the pattern of light. Preferably, the pattern of light comprises an amber colored light to provide a signal.

[0011] In one aspect, the light conduiting member includes a light input surface and a light emitting surface. In one form, at least a portion of the light emitting surface is generally orthogonal to the light input surface. In further aspects, the light conduiting member includes a plurality of light conduiting portions with each including a light input surface and a light emitting surface and first and second side walls. The side walls provide internal light reflecting surfaces and direct light from the light source through the light conduiting portions and through said light emitting surfaces. In preferred form, the signal light includes a plurality of light sources, with each being associated with the light conduiting portions.

[0012] In other aspects, the light conduiting member includes a first side, a first end, and a second side. The first side defines the light emitting surface and is positioned for facing outward from the housing. The first end defines the light input surface. The second side defines a plurality of internal reflecting surfaces which are arranged to reflect the light from the light source through the first side of the light reflecting member and in the light pattern. In further aspects, the light pattern includes a plurality of light regions, with each of the light regions having a first leading edge generally parallel with the vehicle and a second leading edge generally angled away from the vehicle. For example, the internal reflecting surfaces may comprise generally angled planar surfaces provided on the second side of the light conduiting member.

[0013] In another aspect, the exterior mirror system includes a second light conduiting member which is positioned in a front facing portion of the housing wall of the exterior mirror assembly and directs light at least forwardly of the vehicle. Preferably, the second light reflecting member wraps around an outer portion of the housing wall for directing light laterally with respect to the vehicle.

[0014] According to yet another form of the invention, an exterior mirror assembly for vehicle includes a mirror housing having a reflective element and a positioning device for adjusting the position of the reflective element, and a signal light mounted to a portion of the assembly. The signal light includes a light source and a reflector, which includes a plu-

rality of faceted light reflecting surfaces for directing light from the light source forwardly, rearwardly, and laterally of the vehicle. The faceted reflecting surfaces are adapted to restrict light from extending into the vehicle so that a driver seated in the vehicle does not directly observe the pattern of light.

[0015] In one aspect, the faceted reflector surfaces may comprise either planar reflective surfaces, concave reflective surfaces, or convex reflective surface. Preferably, at least one of the faceted reflective surfaces comprises a concave reflective surface.

[0016] In other aspects, the signal light includes a housing, which includes a recessed portion defining a curvilinear wall. The light source is positioned in the recessed portion, and the reflector is positioned along the curvilinear wall. Light emitted from the light source is directed outwardly from the light module and forwardly, rearwardly, and laterally of the vehicle and is restricted from extending into the vehicle so that the driver seated in the vehicle does not directly observe the light pattern.

[0017] According to another form of the invention, the exterior mirror assembly for vehicle includes a powerfold exterior mirror system. The powerfold exterior mirror system includes a folding portion and a non-folding portion, with the non-folding portion being adapted to mount to the vehicle, and the folding portion including a reflective element and being adapted to move between a normal viewing position and a folded position. At least one security light is substantially positioned in either the folding portion or the non-folding portion, which is adapted to project a pattern of light from the exterior mirror assembly to create a lighted security zone in an area adjacent the vehicle.

[0018] In one aspect, the security light is positioned in the folding portion of the exterior mirror assembly. In further aspects, the exterior mirror assembly further includes an actuator, which adjusts the position of the security light in the folding portion when the folding portion moves to its folded position whereby the orientation of the lighted security zone remains substantially unaffected by the movement of the folding portion.

[0019] In another aspect, the security light is mounted to the non-folding portion of the exterior mirror assembly. In further aspects, the security light includes a housing, a light source positioned to the housing, a light reflecting member supported in the housing, and a cover. The light reflecting member directs light from the light source through the cover. Preferably, the housing is substantially positioned in the non-folding portion of the exterior mirror assembly. Furthermore, the cover is preferably substantially flush with an outer surface of the non-folding portion to reduce the aerodynamic drag of the security light.

[0020] It can be appreciated from the foregoing that the exterior mirror system of the present invention permits an approaching vehicle to observe an actuated signal light without the interference from headlights or brake lights. The exterior mirror system may include a unitary module, which is easily installed or removed for repair, or a signal light assembly which is incorporated into the housing of the mirror assembly.

[0021] These and other objects, advantages, purposes and features in the invention, will become more apparent from the study of the following description taken in conjunction with the drawings.

DESCRIPTION OF THE PREFERRED EMBODIMENTS

[0022] FIG. 1 is a perspective view taken from the front of a mirror assembly (rear of the vehicle) incorporating the invention;

[0023] FIG. 2 is a rear view of the mirror assembly in FIG. 1;

[0024] FIG. 3 is a top view of the mirror assembly in FIG. 1;

[0025] FIG. 4 is the same view of FIG. 1 of an alternative embodiment of the invention;

[0026] FIG. 5 is a block diagram of a control system according to the invention;

[0027] FIG. 6 is a block diagram of an alternative embodiment of a control system according to the invention;

[0028] FIG. 7 is a breakaway perspective view of the system in FIG. 1 revealing internal components thereof;

[0029] FIG. 8 is a sectional view taken along the lines VIII-VIII in FIG. 7;

[0030] FIG. 9 is a sectional view taken along the lines IX-IX in FIG. 7;

[0031] FIG. 10 is a side elevation of a vehicle illustrating the security zone light pattern generated by a security light according to the invention;

[0032] FIG. 11 is a top plan view of the vehicle and light pattern in FIG. 10;

[0033] FIG. 12 is a rear elevation of the vehicle and light pattern in FIG. 10;

[0034] FIG. 13 is a side elevation of a vehicle illustrating the light pattern generated by a signal light useful with the invention;

[0035] FIG. 14 is a top plan view of the vehicle and light pattern in FIG. 13;

[0036] FIG. 15 is a rear elevation of the vehicle and light pattern in FIG. 13;

[0037] FIG. 16 is the same view as FIG. 7 of a first alternative light source according to the invention;

[0038] FIG. 17 is the same view as FIG. 7 of a second alternative light source;

[0039] FIG. 18 is the same view as FIG. 7 of a third alternative light source;

[0040] FIG. 19 is the same view as FIG. 7 of a fourth alternative light source; and

[0041] FIG. 20 is the same view as FIG. 7 of the invention embodied in an alternative mirror structure.

[0042] FIG. 21 is a plan view of a vehicle with an exterior rearview mirror assembly of the present invention mounted to the vehicle illustrating the light pattern from a signal light mounted in the exterior rearview mirror assembly;

[0043] FIG. 22 is a perspective view of the driver's side exterior rearview mirror assembly of FIG. 21;

[0044] FIG. 23 is a top plan view of the exterior rearview mirror assembly of FIG. 22;

[0045] FIG. 24 is a cross-section view taken along line XXIV-XXIV of FIG. 23;

[0046] FIG. 25 is a perspective view of a light reflecting member of the exterior rearview mirror assembly of FIGS. 22 and 23;

[0047] FIG. 26 is a top plan view of the light reflecting member of FIG. 25;

[0048] FIG. 27 is an elevation view of a second embodiment of the exterior rearview mirror assembly of the present invention;

[0049] FIG. 28 is a bottom plan view of the exterior rearview mirror assembly of FIG. 27;

[0050] FIG. 29 is a plan view of a light module of the exterior rearview mirror assembly of FIG. 28;

[0051] FIG. 30 is a perspective view of a third embodiment of the exterior rearview mirror assembly of the present invention;

[0052] FIG. 31 is an exploded perspective view of a signal light of FIG. 30;

[0053] FIG. 31A is a front elevation of a light source of the signal light of FIG. 31;

[0054] FIG. 31B is a side view of the light source of FIG. 31A;

[0055] FIG. 32A is a plan view of a second embodiment of the signal light of FIG. 31;

[0056] FIG. 32B is a plan view of a third embodiment of the signal light of FIG. 31;

[0057] FIG. 33 is a plan view of a fourth embodiment of the exterior rearview mirror assembly of the present invention shown mounted to a vehicle;

[0058] FIG. 34 is an enlarged plan view of the exterior rearview mirror assembly of FIG. 33 illustrated in a normal extended position;

[0059] FIG. 35 is an enlarged plan view of the exterior mirror assembly of FIG. 33 in a folded position;

[0060] FIG. 36 is a cross-sectional view taken along line XXXVI-XXXVI of FIG. 34 illustrating a light module of the exterior rearview mirror assembly of FIG. 33 and a positioning mechanism for the light module;

[0061] FIG. 37 is an elevation view of one the exterior rearview mirror assemblies of FIG. 33; and

[0062] FIG. 38 is an elevation view of a fifth embodiment of the exterior rearview mirror assembly of the present invention.

DETAILED DESCRIPTION OF THE PREFERRED EMBODIMENTS

[0063] Referring now specifically to the drawings, and the illustrative embodiments depicted therein, a vehicle personal security lighting system 25 includes an exterior mirror assembly 26 having a conventional reflectance element 28, a security light 30, preferably white, or clear, and a signal light 32, preferably red, incorporated in a housing, or casing, 34. Casing 34 is connected by a neck 36 to a stationary panel or sail 38 adapted for incorporation with the forward portion of the vehicle side window assembly, and which mounts mirror assembly 26 to the door of a vehicle 40 (see FIG. 10). Reflectance element 28 may be any of several reflectors, such as glass coated on its first or second surface with a suitable reflective layer or layers, such as those disclosed in U.S. Pat. No. 5,179,471, the disclosure of which is hereby incorporated by reference herein, or an electro-optic cell including a liquid crystal, electrochromic, or electrochemichromic fluid, gel or solid-state compound for varying the reflectivity of the mirror in response to electrical voltage applied there across as disclosed in U.S. Pat. No. 5,151,824, the disclosure of which is hereby incorporated by reference herein.

[0064] With reference to FIGS. 7 and 8, as is conventional, reflectance element 28 is mounted to a bracket 43 by an actuator 42. Casing 34 is mounted to bracket 43. Actuator 42 provides remote positioning of reflectance element 28 on two orthogonal axes. Such actuators are well known in the art and may include a jackscrew-type actuator 42 such as Model No. H16-49-8001 (right-hand mirror) and Model No. H16-49-

8051 (left-hand mirror) by Matsuyama of Kawagoe City, Japan, as illustrated in FIG. 7, or a planetary-gear actuator 42' such as Model No. 540 (U.S. Pat. No. 4,281,899) sold by Industrie Koot BV (IKU) of Montfoort, Netherlands, as illustrated in FIG. 20. As is also conventional, the entire casing 34 including actuator 42, 42' is mounted via bracket 43 for break-away motion with respect to stationary panel 38 by a break-away joint assembly 44. Breakaway joint assembly 44 (FIG. 9) includes a stationary member 46 attached to vehicle 40, a pivoting member 48 to which bracket 43 and casing 34 are attached, and a wire-way 50 through which a wire cable 52 passes. Wire cable 52 includes individual wires to supply control signals to actuator 42, 42', as well as signals to control the level of reflectivity, if reflective element 28 is of the variable reflectivity type noted above, such as an electrochromic mirror. Power may also be supplied through cable 52 for a heater (not shown) as disclosed in U.S. Pat. No. 5,151,824 in order to evaporate ice and dew from reflective element 28.

[0065] With reference to FIG. 5, actuator 42, 42' receives a first set of reversible voltage signals from a switch 54, in order to bidirectionally pivot in one axis, and a second set of reversible signals from a switch 56, in order to bidirectionally pivot in the opposite axis, as is conventional. Switches 54 and 56 are actuated by a common actuator (not shown) that is linked so that only one of the switches 54 and 56 may be actuated at a time. In this manner, actuator 42, 42' may utilize one common conductor for both switches 54, 56.

[0066] Each of the security light 30 and signal light 32 includes a light source 60 and reflector 62 behind a lens 64 (FIG. 8). Light source 60, reflector 62 and lens 64 are designed for security light 30 to project a pattern 66 of light, such as white light, through a clear, non-filtering lens, in order to establish a security zone around the vehicle (FIGS. 10-12). Pattern 66 extends rearward from mirror assembly 26. Vertically, pattern 66 contacts the ground at 68 in the vicinity of entry and exit by the vehicle occupants (FIGS. 10 and 12). Laterally, pattern 66 fans out into contact with the side 70a, 70b of the vehicle. This contact washes the sides of the vehicle to reflect the light in order to further illuminate the area in order to establish the security lighting zone (FIGS. 11 and 12). In a preferred embodiment, pattern 66 extends rearwardly from mirror assembly 26 without projecting any portion of the pattern forwardly of the mirror assembly.

[0067] Signal light 32 generates a light pattern 72, which is directed generally horizontally rearwardly of vehicle 40 (FIGS. 13-15). Pattern 72 is laterally directed substantially away from side 70a, 70b of vehicle 40 so that the driver of vehicle 40 does not directly intercept pattern 72, although a minor intensity (such as 10%) of the pattern is intercepted by the driver in order to provide awareness of the actuating of the signal light. Pattern 72 fans laterally away from side 70a, 70b to an extent that is parallel the face of reflectance element 28, which is substantially perpendicular to side 70a, 70b (FIG. 14). Thus, the driver of another vehicle (not shown) passing vehicle 40 on the left or right side of vehicle 40 will intercept pattern 72 while the vehicle is behind and beside vehicle 40. Although, in an illustrated embodiment, lens 64 of signal light 32 is substantially planar, lens 64 of signal light 32 could be made to wrap around the outward side of casing 34 in order to function as a side marker for the vehicle as is required in some European countries.

[0068] Vehicle mirror assembly security system 25 is actuated by a control system 74 (FIG. 5). Control system 74 includes means for actuating security light 30 including a

remote transmitting device 76 and a stationary receiving device 78. Transmitting device 76 may be remotely carried by the vehicle operator and includes switches 80 and 81 in order to actuate the transmitting circuitry to transmit a signal form antenna 82, which is received by antenna 84 of receiving device 78. Receiving device 78 is mounted in the vehicle, such as in the vehicle trunk compartment, and includes an output 86 in order to operate remote door lock circuit 88, as is conventional. Output 86 is, additionally, provided as an input 90 of a lockout circuit 92, whose output 94 is supplied to security lamp 30. Input 90 may additionally be actuated by a timeout circuit 96, which is conventionally supplied in a vehicle in order to dim the interior lights, following a slight delay, after the occurrence of an event, such as the opening and closing of the doors of the vehicle. Signal light 32 is actuated on line 98 from either a turn indicator circuit 100 or a stop lamp indicator circuit 102, both of which are conventionally supplied with vehicle 40.

[0069] In operation, when the operator actuates switch 80 of transmitting device 76, receiving device 78 produces a signal on output 86 in order to cause remote door lock circuit 88 to unlock the doors. Alternatively, actuation of switch 81 on remote transmitting device 76 causes receiving device 78 to produce a signal on output 86 to cause remote door lock circuit 88 to lock the vehicle doors. The signal on output 86 actuates security lamp 30 provided that lockout circuit 92 does not inhibit the signal. Lockout circuit 92 responds to operation of the vehicle in order to avoid actuation of security lamp 30 when the vehicle is in motion. Such lockout circuits are conventional and may be responsive to placing of the vehicle transmission in gear or sensing of the speed of the vehicle, or the like. Security lamp 30 is also actuated, in response to interior lighting device timeout circuit 96, whenever the interior lights of the vehicle are being actuated by timeout circuit 96, provided that lockout circuit 92 does not inhibit the signal from security lamp 30. This is provided in order to allow security lamp 30 to be actuated in response to the entry to, or exit from, vehicle 40 without the operator utilizing transmitting device 76 to lock or unlock the doors. Signal lamp 32 is actuated in response to turn indicator circuit 100 whenever the operator moves the indicator stick in the direction of that particular signal lamp 32. Signal lamp 32 may additionally be actuated from stop lamp circuit 102 in response to the driver actuating the vehicle's brakes.

[0070] In the embodiment illustrated in FIGS. 1 and 5, lens 64 of signal lamp 32 is adapted to filter the light provided from lamp 32 so as to be red and is provided for vehicles 40 in which the stop lamps and rear turn indicator lamps are, likewise, red. Because signal lamp 32 shines red, pattern 72 is restricted from extending forward of the vehicle. This is in order to comply with regulations prohibiting red lights from causing confusion with emergency vehicles by shining forward of the vehicle.

[0071] For vehicles having red stoplights and amber turn indicators in the rear, a vehicle mirror security assembly 25' includes an exterior mirror assembly 26' and a control system 74' (FIGS. 4 and 6). Exterior mirror assembly 26' includes a security light 30', preferably white or clear, and a pair of signal lights 32a' and 32b'. Signal light 32a' is amber and is actuated directly from turn indicator circuit 100'. This amber color can be provided either by an amber light bulb or source, or a filtering lens providing an amber color. Signal light 32b' is red and is actuated directly from stop lamp circuit 102'. Each of the light patterns generated by signal lights 32a' and

32b' substantially correspond with light pattern **72**. The light pattern generated by security light **30'** is substantially equivalent to pattern **66**. With the exception that turn signal indicator circuit **100'** actuates signal light **32a'** and stop lamp circuit **102'** actuates signal light **32b'**, control system **74'** operates substantially identically with control circuit **74**.

[0072] In the illustrated embodiment, light source **60**, for both security light **30** and signal light **32**, may be supplied as a conventional incandescent or halogen lamp **60a** (FIG. 7). Alternatively, a conventional incandescent fuse lamp **60b** may be used (FIG. 16). Alternatively, a vacuum fluorescent lamp **60c**, which is available in various colors, may be used (FIG. 17). Alternatively, a light emitting diode **60d** may be used (FIG. 18). As yet a further alternative, a fiber optic bundle **104** forming a light pipe may be positioned to discharge light behind lens **64**. Fiber optic bundle **104** passes through breakaway joint **44** in wire-way **50** in order to transmit light from a source (not shown) within vehicle **40**. By way of example, lens **64** may be supplied as a segmented lens, a prismatic lens, or a Fresnel lens in order to generate light patterns **66** and **72**. Bracket **43** and breakaway joint **44** are marketed by Donnelly Corporation, the present assignee, of Holland, Mich. The remote actuator composed of remote transmitting device **76** and stationary receiving device **78** may be radio frequency coupled, as is conventional. Alternatively, they may be infrared coupled as illustrated in U.S. Pat. No. 4,258,352.

[0073] Although the invention is illustrated in a mirror assembly utilizing an automatic remote actuator, it may also be applied to manual remote actuators and handset actuators. As previously set forth, reflectance element **28** may be conventional or may be supplied as an electrochromic self-dimming mirror. Although the invention is illustrated with breakaway joint **44**, the invention may also be applied to mirrors that are rigidly mounted to the vehicle.

[0074] Referring to FIGS. **21-23**, the numeral **210** generally designates a driver's side exterior mirror assembly of the present invention, with the numeral **210'** generally designating a passenger's side exterior mirror assembly of the present invention which is preferably a mirror image of driver's side exterior mirror assembly **210**. Exterior rearview mirror assembly **210** includes a mirror casing or housing **212**, which includes a sail **213** that is adapted to mount on a vehicle, a reflective element **214**, which is supported in casing **212**, and a signal light **216** which is also supported in casing **212**. Signal light **216** is adapted to direct light into the blind spot of the driver and, preferably, provides a light forwardly and rearwardly of the vehicle so that vehicles approaching the vehicle may observe the signal light. Additionally, signal light **216** is adapted to project light laterally with respect to the vehicle to provide a side light and so function as a side marker. Furthermore, it should be understood that light pattern **217** is generally cone shaped and may project above and below the horizontal plane extending through mirror assembly **210** similar to the illustration in FIG. **15** and preferably projects light above and below the horizontal plane by in a range of about 5E to about 25E and, more preferably, about 15E. As will be more fully described, signal light **216** is preferably adapted to direct the light in a light pattern **217** (with passenger side exterior rearview mirror assembly **210'** having a mirror image light pattern **217'**), such that the light does not extend into the cabin of the vehicle to distract the driver of the vehicle. Furthermore, by projecting light rearwardly, forwardly, and to the side of the vehicle, approaching vehicles,

whether from the forward direction of the vehicle or from the rearward direction of the vehicle or vehicles that are entering the blind spot of the vehicle, can observe the signal light and have advanced notice that the driver of the vehicle intends to make a lane change or turn.

[0075] Rearview mirror assembly **210** may comprise a fixed position exterior rearview mirror assembly or may comprise a break-away rearview mirror assembly, which moves between a normal operating position, in which the rearview mirror assembly is extended from the vehicle, to a folded position against the body of the vehicle when the exterior rearview mirror assembly **210** is impacted with sufficient force. Reference is made to the previous embodiment, exterior mirror assembly **26**, for one example of a break-away rearview mirror assembly.

[0076] Casing **212** is cup shaped and includes a rearwardly facing opening **212a** in which reflective element **214** is supported. Casing **212** is preferably injection molded from a suitable plastic, such as nylon, acrylonitrile butadiene styrene (ABS) or suitable resinous plastic, or the like, which is commercially available under the trademark TERLURAN KR2889®, by BASF Company of Wyandotte, Mich. Alternately, other resinous, melt processible plastics or moldable materials such as mineral-filled or glass filled nylon or polyester and polypropylene could be used to form case **212**. A suitable nylon is 13% glass modified nylon 6:6 sold as ZYTEL 71G13L® by I.E. DuPont de Nemours & Company of Wilmington, Del., or PA123G13BK-47 by Bay Resins Inc. of Millington, Md. A suitable polypropylene is TENITE P6M4Z-007® by Eastman Chemical Products, Inc., Kingsport, Tenn. Alternately, casing **212** may comprise a fiber reinforced nylon plastic, thermoplastic, or polypropylene or other similar thermoplastic or thermoset materials.

[0077] As described above, reflective element **214** is supported in casing **212**. As best seen in FIG. **24**, reflective element **214** is mounted to a backing plate **214a** which is supported by a positioning device, such as an actuator **218**, which provides adjustment for reflective element **214**. Actuator **218** is supported on a mounting bracket **220**, which in turn is secured to casing **212** on mounting bosses **222** provided on casing wall **224**. In the illustrated embodiment, actuator **218** comprises an electrical actuator, which pivots reflective element **214** in casing **212**. Preferably, actuator **218** comprises dual axis positioning device that permits adjustment of the position of the reflective element **214** and backing plate **214a** about both vertical and horizontal axes as is known in the art. It should be understood, however, other positioning devices may be used including manually operated actuators, a remote manually operated actuators, such as a BODEN cable actuator, or the like.

[0078] Reflective mirror element **214** may comprise a conventional non-electro optic planar or convex mirror element including a metallic reflector coated glass substrate, such as with a thin chromium or chromium alloy reflector coating, or a non-metallic reflector layer, such as a dichroic layer as described in U.S. Pat. No. 5,207,492 to Roberts et al. or a reflector comprising a silicon reflective layer such as described in U.S. Pat. No. 5,535,056 to Caskey et al., which are herein incorporated by reference in their entireties. Alternately, reflective element **214** may comprise a variable reflective electro optic element, such as electrochromic mirror element comprising one of several types of electrochromic elements, for example an element of the electrochromic type, which is disclosed in U.S. Pat. No. 5,140,455

issued to Varaprasad et al., or may be of the solid state type such as disclosed in U.S. Pat. No. 4,712,879 issued to Niall R. Lynam et al., U.S. patent application Ser. No. 08/023,675, filed Feb. 22, 1993, by Varaprasad et al., U.S. patent application Ser. No. 08/913,557, filed Feb. 8, 1994, by Varaprasad et al., and U.S. patent application Ser. No. 08/238,521, filed Mar. 5, 1994, by Varaprasad et al., now U.S. Pat. No. 5,668,663, all commonly assigned with the present application to Donnelly Corporation of Holland, Mich., the disclosures of which are herein incorporated by reference in their entirety. Such electrochromic elements comprise an electrically responsive electrochromic medium that modulates reflectivity from a reflective element. Such electrochromic mirror elements are continuously variable and exhibit multiple reflectant states as the voltage applied thereto is varied. Alternately, reflective element 214 may comprise other electro optic mirror elements such as a liquid crystal mirror and the like. Where reflective element 214 comprises an electrochromic mirror element, the electrochromic mirror element is preferably driven by signals produced by a variable reflectant system of the type disclosed in U.S. patent application Ser. No. 08/316,047 for a "Modular Variable Reflectant Mirror Assembly", filed Sep. 30, 1994, by Kenneth L. Schierbeek et al., now U.S. Pat. No. 5,659,423 which is herein incorporated by reference in its entirety.

[0079] It should be understood, although not described herein, that one or more electrical or electronic components may be mounted in casing 212, such as the interface transaction system described in U.S. pending patent application entitled A VEHICLE MOUNTED REMOTE TRANSACTION INTERFACE SYSTEM filed by Martin DeVries and Niall R. Lynam on Apr. 8, 1998, Ser. No. 09/057,428, now U.S. Pat. No. 6,158,655, and/or an electronic module, which may include one or more electrical or electronic devices, such as antennas and circuitry for rain sensors, heating elements, and the like, as described in pending U.S. patent application entitled MODULAR REARVIEW MIRROR ASSEMBLY INCLUDING ELECTRONIC MODULE, Ser. No. 08/702,228 which was filed Aug. 23, 1996, by Niall Lynam et al., now U.S. Pat. No. 6,019,475, and which are commonly assigned to Donnelly Corporation of Holland, Mich., the disclosures of which are incorporated by reference herein in their entirety.

[0080] As best seen in FIGS. 22 and 26, signal light 216 is positioned in a lower portion or bottom rim of casing 212 and includes a light conducting member or light pipe 230 and a light source 232. The color of the light emitted from signal light 216 is preferably amber, yellow-amber, or amber-red, depending on its application and may be generated by a bulb or cover, a filter, a reflector which surrounds the light source, the light source or the light pipe or a combination of one or more of the aforementioned devices. For example, light source 232 may produce, for example an amber light from a coating on the light source bulb or from a gas enclosed in the bulb or from the light producing element of the light source. In addition, signal light 216 preferably produces a light intensity of at least about 0.3 and in the range of about 0.3 to about 200 candela, more preferably, in a range of about 0.6 to about 150 candela, and most preferably, in a range of about 1.0 candela to about 25 candela, such that signal light 216 preferably meets the specification for the applicable automobile industry standards such as Japanese Industrial Standard (JIS) 5500; ECE Reg. 48; EEC No. 76/759; and/or E/ECE/324 Reg. No. 6. Moreover, signal light 216 may produce a variable light pattern intensity. For example, referring to FIG. 21, in

the region 217c of light pattern 217 which is forward of transverse axis 211b, the light intensity may have one intensity value, while the region 217d rearward of transverse axis 211b may include another light intensity value. Furthermore, each region 217c or 217d may have a variable intensity pattern. For example, the portion of the region 217c or 217d nearest to axis 211b may have a higher light intensity than portions of the region 217c or 217d angled further away from axis 211b. In this manner, signal light 216 is visible to persons on the road who are approaching the vehicle from the forward or rearward direction or persons located adjacent the vehicle.

[0081] Light pipe 230 is preferably formed, such as by molding, from a plastic, such as polycarbonate, acrylic or the like, and is, therefore, substantially rigid. Alternately, light pipe 230 may comprise a flexible bundle of individual fibers or an individual flexible fiber. Furthermore, light pipe 230 is adapted to transmit or direct light from light source 232 along a longitudinal axis 230a of light pipe 230 and reflect the light from light source 232 as it extends through the light pipe in directions generally lateral to the longitudinal axis 230a of light pipe 230, as will be more fully described below.

[0082] Referring to FIG. 26, light pipe 230 includes a first side 234, which provides a light emitting surface and is substantially planar, and an opposed side 236 which includes a plurality of faceted surfaces 238. Faceted surfaces 238 provide internal light reflecting surfaces and have a stepped configuration, with the cross-section of light pipe 230 being incrementally reduced from a first end or approximate end 240 to a second end or distal end 242. Light pipe 230 is preferably positioned in casing 212 such that first end 240 is positioned closer to the vehicle than second end 242 and such that first side 234 is oriented facing outwardly from casing 212. Moreover, light pipe 230 is preferably positioned in casing 212 with minimal protrusion into the slipstream of the mirror assembly so as to reduce the aerodynamic drag and, most preferably, with first side 234 substantially flush with the outer surface of the lower portion or bottom rim of casing 212. First end 240 is substantially planar and generally orthogonal to first side 234 and defines a light input surface 244. Light source 232 is positioned adjacent light input surface 244 and preferably in substantially close proximity to light input surface 244 so that a high percentage, if not all, light emitted from light source 232 is directed into light pipe 230. Optionally, light source 232 may be optically coupled to light input surface 244 by, for example, an optical adhesive.

[0083] As described above, first side 234 of light pipe 230 provides light emitting surface 245, through which light from light source 232 is emitted. Again referring to FIG. 26, when light enters light pipe 230 through light input surface 244, the light rays are internally reflected off faceted surfaces 238 and, some of which, are internally reflected off planar surface 234a of first side 234 so that the light from light source 232 is directed laterally through first side 234 and through light emitting surface 245 in directions which are angled with respect to first side 234. In preferred form, the light pattern emitted light pipe 230 includes a plurality of light regions which are angled away from the side of the vehicle to restrict the light from entering into the vehicle. In this manner, light pipe 230 transmits or conduits the light from light source 232. It should be understood that the geometry of light pipe 230 permits light pipe 230 to direct light in a manner that relies on internal reflections within light pipe 230; therefore, no reflective coatings are necessary. Consequently, light pipe 230 is easier and less costly to manufacture. However, it can be

appreciated that faceted surfaces 238 may include reflective coatings, such as formed by vacuum metalizing.

[0084] As best seen in FIG. 24, light pipe 230 is mounted between a lower or bottom wall portion 224a of casing wall 224 and a flange 246 which extends from a back wall portion 224b of casing wall 224. Similarly, light source 232 is supported between flange 246 and lower portion 224a of casing wall 224 and is positioned adjacent first end 240 of light pipe 230, as described above. It should be understood from the foregoing, that reflective element 214 is independently mounted from light pipe 230 and, therefore, can move independently from light pipe 230, which is preferably mounted in a fixed position in casing 212.

[0085] Optionally, signal light 216 includes a second light pipe 250. Light pipe 250 is a similar construction to light pipe 230, except that light pipe 250 includes a curved outer surface 252 which follows the curvature of casing 212 as shown in FIGS. 23 and 24 and which defines a light emitting surface. Light pipe 250 includes a first or approximate end 254, which provides a light input surface, and a second or distal end 256. As best seen in FIG. 23, light pipe 250 wraps around casing 212 to permit light to be reflected generally laterally from exterior rearview assembly 210 to provide a side signal or side marker to cars which are positioned in the blind spot of the vehicle. A second light source 258 is positioned adjacent first end 254 so that light which is emitted from light source 258 is directed along the longitudinal axis 250a of light pipe 250 and laterally with respect to longitudinal axis 250a in a similar manner to light pipe 230.

[0086] Preferably, light pipes 230 and 250 direct light in light pattern 217, shown in FIG. 21. Light pattern 217 is defined between leading edges 217a and 217b, wherein leading edge 217a forms an angle α with respect to the vehicle axis 211a of vehicle 211, as measured in a counter clock-wise direction, and leading edge 217b forms an angle β with respect to vehicle axis 211a as measured in a clock-wise direction. These angles vary depending upon the applicable guidelines or specifications of the country in which the vehicle is sold. For example, α may be in a range of about 0E to about 45E. β may be in a range of about 0E to about 15E. In some countries, α may be in a range of about 0E to about 40E, and β may be in a range of about 0E to about 5E.

[0087] Light sources 232 and 258 are preferably energized by power lines 260 which extend through flange 246 so that they can be bundled along with other power or communication lines which extend from exterior mirror casing 212 to the interior of the vehicle to couple light sources 232 and 258 to the electrical system of the vehicle. Light sources 232 and 258 may comprise a laser diode, a solid state emitter such as a light emitting diode, an incandescent light source, a fluorescent light source, such as a cold cathode fluorescent light, a phosphorous lamp, a neon light, a discharge lamp, an arc lamp, and an electro-luminescent light, including inorganic or organic electro-luminescent sources.

[0088] Optionally, two or more of such light sources may be incorporated into exterior mirror assembly 210 for directing light into the respective light input surfaces 244 and 256 of light pipes 230 and 250, respectively. Furthermore, a plurality of light emitting sources may be grouped to provide a more intense illumination. As described above, a variety of emitting sources may be used as light emitting sources 232 and 258, including but not limited to a very high intensity amber and reddish-orange light emitting diode (LED) sources, such as solid state light emitting diode sources utilizing double

hetero-junction AlGaAs/GaAs Material, Technology, such as very high intensity LED lamp T-13/4 (5 mm) HLMT-4100/4101, available from Hewlett Packard Corporation, Palo Alto, Calif., for which used transparent substrate aluminum indium gallium phosphide (AlInGaB) Material Technology, commercially available from Hewlett Packard Corporation under the designation T-13/4 (5 mm) HLMT-DI.00, HLMT-CH00, HLMT-CL00, HLMT-CH15, HLMT-DH00 or which use InGaAlB Material Technology available from Toshiba Corporation of Laythem, N.Y. such as under the designation TLRH180D. Light emittance colors provided by such solid state sources include orange, yellow, amber, and reddish-orange, preferably without the need for ancillary filters. The preferred solid state light emitting diodes operate at 25E C, or thereabouts, and operate with a forward voltage of about 2 volts to about 5 volts; have a luminance intensity (measured at peak of the spacial radiation pattern which may not be aligned with a mechanical access of the source package) of a minimum at 20 mA current of about 500 to about 5,000 lcd (typically about 700 to about 7,000 mcd); operated at a forward current of about 20 mA to about 50 mA; emit with a dominant wave length (CIE Chromaticity diagram) of about 530 nm to about 60 nm; and have a viewing angle to $\theta^{1/2}$, where $\theta^{1/2}$ is the off axis angle where the luminance intensity is $1/2$ the peak intensity of about 5E to about 25E.

[0089] Alternately, vacuum fluorescent sources such as 12-volt battery driven high luminescent vacuum fluorescent sources may be used. It may also be advantageous to use sources which operate efficiently at about 12 volts or lower since these voltages are particularly suited to conventional motor vehicle electrical systems. Also, ultra high luminescent vacuum fluorescent sources such as those suitable for head set display applications in motor vehicles may be used with appropriate circuitry.

[0090] Alternately, non-LED non-incandescent light emitting sources can be used such as electro-luminescent sources or semiconductor laser sources. Electro-luminescent sources may be either inorganic or organic electro-luminescent sources. Light emitting sources 232 and 258, preferably have well defined light patterns, such as a cone of directed light which eliminates the need for reflectors or other separate optical components that direct the light where desired. In addition, light emitting sources 232 and 258 are preferably mounted on or within mirror casing 212 as described previously. Alternately, light sources 232 and 258 may be in the form of a light pipe which directs light from a remote light source located in the vehicle. Such a light pipe may comprise, for example a flexible light pipe such as a fiber optic cable. In which case, the distal end of the fiber optic cable is positioned adjacent the respective light input surfaces 244 and 256 of light pipes 230 and 250.

[0091] In the event that the light emitting source comprises a light emitting diode, a resistor is preferably connected in series with a respective light emitting diode to act as a voltage divider so as to reduce the ignition voltage of the vehicle, which is in the range of 9-16 volts (normally 12 volts), for the desired operating voltage of the light emitting diode, which is typically on the order of about one volt to about five volts. Each resistor preferably has a resistance of less than about 1,500 ohms and greater than about 100 ohms, more preferably, less than about 1,000 ohms and greater than about 200 ohms.

[0092] Although illustrated herein as being located along the bottom rim of the exterior trim housing, other locations

are possible for the signal light of the invention, including the top and outboard rim of the exterior housing, and even elsewhere on the exterior vehicle body as appropriate.

[0093] Referring to FIGS. 27-29, a second embodiment 310 of the exterior rearview mirror assembly of the present invention is illustrated. Exterior rearview mirror assembly 310 includes a housing or casing 312 in which a reflective element 314 is supported. In addition, exterior rearview mirror assembly 310 includes a signal light and, preferably, a signal light 316 which provides a light pattern similar to light pattern 217 described in reference to the first embodiment and is supported by casing 312 which will be further described below.

[0094] Reflective element 314 is mounted to a backing plate 314a, which is supported on a positioning device or actuator 318, which in turn is mounted to a mounting bracket 320. In the illustrated embodiment, mounting bracket 320 is supported by mounting bosses 322 provided on casing wall 324 of casing 312. It should be understood, that reflective element 314, therefore, can move independently of the signal light 316, which is preferably mounted in a fixed position relative to casing 312. However, other mounting arrangement may be used for reflective element 314 and for the exterior rearview assembly, including a fixed position exterior rearview mirror assembly or a mounting arrangement in which mounting bracket is rotatably coupled to a vehicle mounting bracket to provide a break-away function of the exterior rearview mirror assembly. In a break-away exterior mirror assembly, signal light 316 is preferably mounted to move with the casing and, therefore, remains fixed relative to the casing.

[0095] As best seen in FIG. 27, signal light 316 is mounted to a bottom wall portion 326 of casing wall 324. Bottom wall portion 326 of casing wall 324 includes a stop or an abutment 328 against which signal light 316 abuts when mounted to casing 312. Signal light 316 is preferably mounted to casing 312 by for example fasteners, such as threaded fasteners, keys, or projecting pins with enlarged heads which provide a snap-fit coupling between signal light 316 and bottom wall 326. Alternately, signal light 316 may include tracks or guides and with casing 312 including a corresponding guide or track so that signal light 316 can be inserted between the respective guides, or tracks. Furthermore, signal light 316 includes a lower most surface 316a which preferably aligns and, more preferably, is flush with the lower most surface 328a of stop 328 so that when installed, signal light 316 follows the aerodynamic contours of casing 312 to provide an aerodynamically contoured exterior rearview mirror assembly 310.

[0096] Referring to FIGS. 28 and 29, signal light 316 includes a housing 330 which includes a cover 331 and a base 332. Base 332 includes a mounting portion and a raised or projecting portion 333 which defines a mounting surface 334. Housing 330 is preferably plastic, such as nylon, a melt processible plastic, including for example polycarbonate, acrylic, or the like and, additionally, matches the color of casing 312. Cover 331, which is preferably a clear plastic cover, extends over base 332 and is secured thereto using conventional means, including for example releasable couplers, including threaded fasteners, snap-fit couplers or the like, or by welding, such as sonic welding, heat staking or the like, or by an adhesive. Cover 331 defines a cavity or space 332a between base 332 and cover 331. Base 332 supports a light source 342, which is housed in cavity 332a, and a light reflecting member 335 which is preferably mounted to mounting surface 334 for reflecting light from light source

342 outwardly from signal light 316. Light reflecting member 335 preferably comprises a multi-faceted reflector having a compound shape and includes a plurality of reflector elements 336, 338, and 340. Each reflector elements 336, 338, and 340 may comprise a metal reflector, such as a stamped aluminum reflector, a polished metal reflector, a painted/coated printed surface with a high specular and/or diffused paint, film, tape, coating, or the like, a vacuum metalized substrate, such as vacuum metalized glass or plastic, a metalized or reflective mineral filled substrate, such as a mineral filled plastic substrate, a reflective metal filled substrate, such as a metal filled plastic, or the like. Each of the respective reflective elements 336, 338, and 340 may have a concave, a convex, or planar surface, or a multiradius surface such as an anamorphic asphere shape.

[0097] Preferably light source 342 is positioned adjacent reflector element 336 and sufficiently spaced from reflector element 336 such that the light emitted from light source 342 reflects off reflector elements 336, 338, and 340 to provide a pattern as shown in FIG. 28. Light source 342 may comprise a bulb, a diode, or the like, and is powered through wiring 343 which extends from signal light 316 to casing 312, for example by way of an opening 330a provided in base portion 332 of housing 330. Optionally, light source 342 may comprise a light pipe (not shown) which delivers or directs light from a remote light source in the vehicle in a similar manner as described in reference to the previous embodiment.

[0098] As described above, cover 331 may be integrally molded with base portion 332. In this manner, light source 342 may be inserted into cavity 332a through opening 330a of base 332. Furthermore, cavity 332a may be reduced such that cavity 332a comprises a light source receiving socket. In addition, signal light 316 may include a light conducting member, such as described in reference to signal light 216 or signal light 416, positioned in cavity or space 332a to further enhance the direction of light emitted from light source 342.

[0099] Referring to FIG. 28, signal light 316 emits light in a light pattern 344, which is defined between leading edges 346 and 348. When mounted to casing 312, light pattern 344 directs light forwardly and rearwardly of the vehicle and to the side of the vehicle but away from the cabin of the vehicle so as to avoid contact with the driver's eyes similar to light pattern 217 in FIG. 21.

[0100] As best seen in FIG. 27, cover or lens 331 extends over housing 330 from a first end or approximate end 352 to a second or distal end 354. For further details of light source 342, reference is made to the description of light sources 232 and 258 as described in reference to the first embodiment. Preferably, cover 331 includes a neutral spectra content and comprises a plastic lens, such as a polycarbonate lens. Furthermore, cover 331 may be a prescription lens such as, a fresnel lens, including a micro fresnel lens, a diffusive optic lens, a diffractive optic lens, a refractive optic lens, a reflective optic lens, a holographic optic lens, a binary optic lens, a clear optic lens, a prismatic lens, a pillow lens, and a sinusoidal optic lens, or the like. In which case, the color of the light from signal light 316 may be introduced by light source 342, a boot or cover over light source 342, a filter, or reflector 335. Similar to as described in reference to light sources 232 and 258, signal light 316 may emit an amber, yellow-amber, or red-amber light. Furthermore, cover 331 may optionally blend with the color of casing 312, with signal light 316 still emitting an amber, amber-yellow or red-amber light. Alternately,

the color of the light may be generated by cover **331** or a combination of any one or more of the aforementioned devices.

[0101] Preferably, signal light **316** produces a light intensity in the range of about 0.3 to about 200 candela, more preferably, in a range of about 0.6 to about 150 candela, and most preferably, in a range of about 1.0 to about 100 candela, such that signal light **316** preferably meets the applicable specifications for the automobile industry, as described in the previous embodiment. In this manner, signal light **316** is visible to persons on the road who are oncoming or approaching the vehicle from the rearward direction. Furthermore, signal light **316** preferably extends to the outer most portion and wraps around the bottom wall **326** of casing **312** so that light emitted from signal light **316** is visible from the side of the vehicle, and vehicles which are in the vehicle's blind spot can clearly see the signal light when actuated.

[0102] Preferably, signal light **316** is a unitary module or modular turn signal which can be easily serviced and/or replaced in its entirety. Furthermore, signal light **316** is preferably at least substantially water impervious and optionally may include a socket or electrical connection to the vehicle electrical wiring system. In addition, as described in reference to the previous embodiment, signal light **316** may incorporate a circuit board for flexible circuitry, which couples to the electrical system of the vehicle for powering light source **342**.

[0103] Referring to FIGS. **30-31**, the numeral **410** designates a third embodiment of the exterior rearview assembly of the present invention. Exterior rearview assembly **410** includes a mirror casing or housing **412**, which includes a sail **413** which is adapted to mount on a vehicle, a reflective element **414** which is supported in housing **412**, and a signal light **416** which is also supported in housing **412**. Signal light **416** is adapted to direct light forwardly and rearwardly of the vehicle so that vehicles approaching from the opposite direction of the vehicle and rearwardly of the vehicle may observe signal light **416**. Additionally, signal light **416** is adapted to project light laterally with respect to the vehicle to provide a side light and so function as a side marker. Similar to exterior mirror assembly **210**, signal light **416** is preferably adapted to direct the signal light in a light pattern **417** such that the light does not extend into the cabin of the vehicle to distract the driver of the vehicle. Furthermore, by projecting light rearwardly, forwardly and laterally from the side of the vehicle, approaching vehicles, whether from the forward direction of the vehicle or from the rearward direction of the vehicle or vehicles that are entering the blind spot of the vehicle, can observe the signal light and have advanced notice if the driver of the vehicle intends to make a lane change or turn.

[0104] Rearview mirror assembly **410** may comprise a fixed position exterior rearview mirror assembly or may comprise a break-away rearview mirror assembly, which moves between normal operating position in which the rearview mirror assembly is extended from the vehicle to a folded position against the body of the vehicle and the exterior rearview mirror assembly **410** is impacted with sufficient force. Examples of break-away rearview mirror assemblies are well known and reference is made to the first embodiment of the exterior rearview mirror assembly for at least one example such a break-away assembly.

[0105] Housing **412** is generally cup-shaped and includes a rearwardly facing opening **412a** in which reflective element **414** is supported. Reference is made to exterior rearview

mirror assembly **210** for examples of preferred material for housing **412**. As described above, reflective element **414** is supported in housing **412**. Preferably, reflective element **414** is mounted on a backing plate **414a**, which in turn is supported by a positioning device, for example an electrical actuator or the like. Again, reference is made to the exterior rearview mirror assembly **210** for an example of how reflective element **414** is supported in housing **412**. Furthermore, reference is made to exterior rearview mirror assembly **210** for examples of preferred reflective elements and for examples of other components which may be mounted or housed in exterior rearview mirror assembly **410**.

[0106] As best seen in FIGS. **30** and **31**, signal light **416** is preferably positioned in a lower portion or bottom rim of casing **412** and includes a light conducting member or light pipe **430** and a plurality of light sources **432**. As described in reference to the previous embodiments, the light emitted from the signal light **416** is preferably yellow, amber, yellow-amber, or amber-red depending on its application. Again, reference is made to the earlier embodiments for examples of how the color is generated. Light pipe **430** is preferably formed, such as by molding, from a plastic material, such as polycarbonate or acrylic or the like, and is, therefore, substantially rigid. As best seen in FIG. **31**, light pipe **430** includes a plurality of light transmitting or conduiting portions **430a**, which are spaced and arranged in a generally radial fashion. Each light transmitting or conduiting portion **430a** includes a leading edge **434**, which defines a light input surface. Furthermore, each light transmitting or conduiting portion **430a** includes a distal surface or outboard edge **436** which defines a light emitting surface which is preferably arranged or formed, to follow the contour of exterior mirror housing **412**. In addition, each light transmitting or conduiting portion **430a** includes side walls **438** and **440**, which extend from light input surface **434** outwardly toward light emitting surface **436** which define radially extending grooves or channels in light conducting member **430**. As best seen in FIG. **31**, side walls **438** and **440** preferably terminate before reaching light emitting surface **436**. Alternately, one or more light conduiting portions may include respective side walls **438** and **440** that extend from their respective light input surfaces **434** to their respective light emitting surfaces **436**. In this manner, light pipe **430** comprises a plurality of discrete light transmitting or conduiting portions rather than a unitary light conduiting or transmitting member.

[0107] Light sources **432** are positioned and, preferably, optically coupled to light input surfaces **434** of each respective light transmitting or conduiting portion **430a**. Referring to FIGS. **31A** and **31B**, in the illustrated embodiment, light sources **432** comprise surface light emitting diodes (LED's) and preferably comprise a flat rectangular wafer **432a** with a projecting emitter **432b**, which are commercially available from the Piranha line of Hewlett Packard. In preferred form, each light input surface **434** includes a recess and, more preferably, a cylindrical groove **434a** for receiving the respective light emitting portion **432b** of the light source **432**. In this manner, the light emitters **432b** of the respective LED's may achieve good optical coupling with light input surfaces **434**. Alternatively, each of the respective light input surfaces **434** of light transmitting conduiting portions **430a** may include a semi-spherical recess for receiving the respective light emitters of the light sources **432**, which will maximize the optical

coupling between light sources **432** and light conducting portions. However, semi-spherical recesses are harder to tool and to assembly.

[0108] Light input surfaces **434** of each light transmitting or conduiting portion **430a** are generally parallel or only slightly angled with respect to its respective light emitting surface **436** such that the light emitted from the respective light source **432** will project outwardly from light emitting surface with minimal reflection inwardly from the light emitting surface. Furthermore, sides **438** and **440** are angled with respect to light input surface **434** such that light from light source **432** is internally reflected and redirected outwardly from light emitting surface **436**. In so doing, light pipe **430** optimizes the internal reflection of each light transmitting or conduiting portion **430a** to efficiently direct the light emitted from light source **432**, which tends to project light in a cone shape light pattern, outwardly through light emitting surface **436**.

[0109] Signal light **416** preferably comprises a module which is preferably removably inserted into a slotted opening or recess **412b** formed in housing **412** of exterior rearview mirror assembly **410**. Preferably, signal light **416** includes a lower housing portion **442** and an upper housing portion or cover **444**. Upper housing portion **444** may be secured to lower housing portion **442** by conventional fasteners, for example fasteners, including screws, snap-fit couplers, or the like, such that light sources **432** are serviceable, or may be welded or adhered to housing **442**, for example by sonic welding, heat staking, or an adhesive, so that signal light **416** can be replaced as a unit. Light conduiting member **430** is positioned in lower housing portion **442** and is preferably integrally molded with housing portion **442** such that light emitting surface or surfaces **436** of light pipe **430** form a portion of the outer perimeter wall **446**. However, it should be understood that light conduiting member **430** may be separately formed from housing portion **442** and, instead, inserted into housing and positioned such that light emitting surface or surfaces **436** is optically coupled to perimeter wall **446**.

[0110] In preferred form, lower housing portion **442** is formed or molded from a clear plastic, including for example polycarbonate, acrylic, or the like. In contrast, upper housing portion **444** may comprise any suitable plastic, for example a melt-processible plastic or moldable material, such as described in reference to casing **212**. Furthermore, upper housing portion **444** may be opaque.

[0111] Each of the respective light sources **432** includes electrical wiring **447**, which extends through housing **442** and through an opening **448** provided in perimeter wall **446** of housing **442**. Optionally, perimeter wall **448** may include an electrical outlet or plug to which the electrical wiring is coupled for coupling to the electrical system of the vehicle. In addition, light sources **432** may be coupled to and powered by a circuit board mounted in housing **442**, which is electrically coupled to the electrical system of the vehicle. Furthermore, light sources **432** may be powered by flexible circuitry, which is electrically coupled to the electrical system of the vehicle, or any other suitable conventional power supply system. Alternately, each individual wire may project from housing **442** for individually coupling to the electrical system of the vehicle.

[0112] As best seen in FIG. 31, upper housing portion **444** includes one or more retaining clips **450** for securing to a corresponding structure provided in housing **412**. In the illustrated embodiment, retaining members **450** comprises con-

ventional bayonet or snap type couplers, but it should be understood that other couplers, such as threaded fasteners, or the like, may be used. As described in preferred form, light conduiting or transmitting portions **430a** rely on internal reflections of the light emitted from light sources **432** to transmit or conduit the light from light source to light emitting surfaces **436**. In this manner, light conduiting member **430** is easy to manufacture and assembly and relies on the geometry of the light input surfaces and side walls in order to produce an effective signal light **416** rather than reflections from reflective surfaces. However, it should be understood, that side walls **438** and **440** may include reflective surfaces, such as vacuum metalized surfaces or the like. However, this would entail additional manufacturing steps and require more careful handling of the article and, consequently, would increase the cost of the signal light **416**.

[0113] Referring to FIG. 32A, signal light **416'** may include bulb shaped light sources **432'**. In a similar manner to signal light **416**, light input surfaces **434'** of light conduiting members **430'** may include recessed portions **434a'** for receiving the respective bulb shaped light emitters **432'**.

[0114] As best seen in FIG. 32B, a third embodiment **416''** of signal light includes a single light source **432''** such as a conventional light bulb to emit light for input into the respective light input surfaces **434''** of each respective light conduiting portion **430a''** of light pipe **430''**.

[0115] It should be understood from the foregoing, that light pipes **430**, **430'**, and **430''** are formed with respective side walls **438** and **440**, **438'** and **440'**, and **438''** and **440''** to guide the light from the respective light source or light sources **432**, **432'**, **432''**, to the outboard edge **431**, **431'**, **431''** of light pipe **430** to form a signal light which directs light rearwardly, laterally, and forwardly of the vehicle. Whether light pipes **430**, **430'**, **430''** are formed as a single unit with a plurality of light transmitting or conduiting portions **430a**, **430a'**, **430a''**, or as a collection of discrete light transmitting or conduiting portions, in which case discrete regions of light will be produced, signal lights **416**, **416'**, and **416''** provide simple and inexpensive light assemblies which are easy to manufacture and install.

[0116] It should be understood that should it be desired to vary the intensity of the signal lights so they are brightest during high ambient lighting conditions, such as on a sunny day, but so that they are dimmer when ambient conditions are lower, such as at night, the intensity of the signal lights can be modulated using a photosensor such as a photoresistor, photodiode, phototransistor, or their like. A photosensor that controls the intensity of the signal light so that it reduces its intensity during low ambient light driving conditions, such as by pulse width modulation on the electrical line powering the LEDs in the signal light, may be mounted integrally with the signal light module itself, or it may be part of the vehicle electronics itself, such as a photosensor mounted as a part of an automatic electrochromic mirror circuit, as part of a vehicle automatic headlamp activation circuit, as part of a headlamp daylight running light control circuit, or their like.

[0117] Referring to FIGS. 33-37, the numeral **510** designates a fourth embodiment of the exterior rearview assembly of the present invention. Exterior rearview assembly **510** comprises a powerfold exterior rearview mirror assembly and includes a housing or casing **512** in which a reflective element **514** is supported. Reflective element **514** is optionally supported in casing **512** in a similar manner to that described in reference to the earlier embodiment and, therefore, reference

is made therein for further mounting details and, additionally, for examples of reflective elements which can be employed. In preferred form, exterior rearview assembly 510 includes a "powerfold" mechanism that is typically operated and actuable/deactuable from within the vehicle cabin either by a user operator switch or by a speed sensor that folds the mirror out when a predetermined vehicle velocity is sensed and that upon activation by the driver causes a folding portion 510a of exterior mirror assembly 510, for example casing 512, to fold or move or pivot about a fold-away axis 511 on a non-folding portion 510b of exterior mirror assembly 510, for example a mounting bracket or the like, from its normally extended viewing position wherein mirror assembly 510 provides a field of view to a compact folded position wherein the rearwardly facing side of the folding portion is disposed generally parallel to the vehicle body (FIGS. 34 and 35). "Powerfold" exterior rearview mirrors are conventional and, therefore, the specific details of the "powerfold" mechanisms are omitted herein. In many European countries, "powerfold" exterior rearview mirror assemblies are used during parking to reduce the width of the vehicle.

[0118] In addition, exterior rearview mirror assembly 510 includes a security light and, preferably, a self-contained, unitary security light module 516 which in the illustrated embodiment is mounted to folding portion 510a of mirror assembly 510 on a bottom wall portion 526 of casing wall 512a (FIG. 36). Security light 516 is preferably of similar construction to unitary light module 200 described in pending application entitled EXTERIOR VEHICLE SECURITY LIGHT Ser. No. 08/687,628, filed on Jul. 26, 1996, by Todd W. Pastrick et al., now U.S. Pat. No. 5,823,654, which is assigned to Donnelly Corporation of Holland, Mich. and which is incorporated herein in its entirety. Security light 516 includes a housing 518, in which a light source 520 and reflector 522 are supported, and a cover or lens 524. Housing 518 is preferably a plastic material, such as polycarbonate, polyester, nylon, acetal, polypropylene or ABS. Cover 524 is optionally welded to housing 518, for example by sonic welding, heat staking or the like, or adhesively attached by an adhesive. Reflector 520 may comprise, for example a polished metal substrate, a vacuum metalized substrate, or a metal filled substrate. As best seen in FIG. 33-37, reflector 520 and lens 524 are adapted to direct light in a light pattern 517. For further details of the components of security light 516, reference is made to the above incorporated pending patent application. As described in the referenced application, security light 516 is adapted to direct light generally rearwardly of the vehicle and to fan out laterally from the vehicle to provide a lighted security zone near or adjacent the vehicle. Furthermore, security light 516 is preferably mounted in or substantially incorporated to casing 512 with minimal protrusion from casing 512 into the slipstream such that security light 516 does not add to the aerodynamic drag of mirror assembly 510 and, most preferably, with lens 524 substantially flush with the outer surface of casing 512. Moreover, in preferred form, at least security light 516 or light source 520 is serviceable.

[0119] As best seen in FIGS. 34 and 35, security light 516 may be optionally rotationally mounted in casing 512 such that when folding portion 510a of exterior rearview mirror assembly 510 is moved to its compact folded position, security light 516 remains in the same orientation with respect to the vehicle such that the light pattern 517 which is projected from security light 516 remains substantially unchanged

despite the repositioning of exterior rearview mirror assembly 510. In other words, security light 516 remains stationary with respect to vehicle V but rotates in casing 512 when exterior mirror assembly 510 moves to its folded position.

[0120] Referring to FIG. 36, security light 516 is mounted in an opening 512b in casing wall 512a. Security light 516 is mounted in opening 512b by a rotatable sleeve or bushing 530 so that security light 516 is rotatable about its axis 516a. In this manner, security light 516 is movably or rotatably mounted in casing 512. Preferably, exterior mirror assembly 510 includes an actuator or driver 528 such as a gear or other suitable mechanism, including a servo-motor driver, a belt, a cylinder, including a hydraulic or pneumatic cylinder, or the like, which repositions or rotates security light 516 about axis 516a to maintain light pattern 517 in a generally fixed position with respect to the vehicle. As best seen in FIG. 36, gear 528 may engage threads 518a formed on a lower portion of or a threaded collar mounted to housing 518.

[0121] Furthermore, exterior rearview mirror assembly 510 may also include a break-away mounting which permits the exterior mirror assembly to fold to a break-away position upon impact. Both of the powerfold and break-away features are commonly known in the mirror art.

[0122] Alternately, security light 516 may be mounted in folding portion 510a in a fixed position; in which case, when folding portion 510a moves to its folded position, security light 516 remains stationary with respect to folding portion 510a but moves with respect to the vehicle. In this embodiment, therefore, security light 516 is preferably oriented such that it projects light to provide a security zone when folding portion 510a is in its folded position, and preferably one that washes the side of the vehicle and that provides adequate ground illumination (an average of at least one lux ground illumination intensity desired, at least five lux preferred) at the front and rear entrances/exits of the vehicle where occupants may enter/exit the cabin. Typically, when a driver of a vehicle with a powerfold exterior mirror approaches the vehicle, the powerfold exterior mirror assembly is in its folded position and does not move to its extended position until the driver is already in the car with the ignition on. However, where the driver of the vehicle uses a remote control for actuating the powerfold exterior mirror assembly as the driver approaches the vehicle, the first embodiment of the powerfold exterior mirror assembly may be preferred so that if the folding portion of the mirror assembly is in its extended position before the driver enters the vehicle, then the security light will provide a lighted security zone adjacent the vehicle which washes the side of vehicle and provides ground illumination at the cabin entrances regardless of the position of the folded portion of the mirror assembly.

[0123] Optionally, the exterior rearview mirror assembly may include a proximity sensor 540 mounted on casing 512 which is electrically coupled to the powerfold control system (not shown). Proximity sensor 540 actuates the powerfold function upon detection of an object, such as another vehicle or wall, or the like. Furthermore, proximity detector 540 may be coupled with the light module control circuitry (not shown) so that when the powerfold function is actuated by the detection of an object, security light 516 will be similarly actuated to rotate with respect to casing 512 to maintain light pattern 517 for the security zone in substantially the same orientation.

[0124] Referring to FIG. 38, a fifth embodiment 610 of the exterior rearview mirror assembly is illustrated. Exterior rear-

view mirror assembly **610** is of similar construction to exterior rearview mirror assembly **510** and also comprises a powerfold mirror assembly. Assembly **610** includes a folding portion **610a**, which houses a reflective element **614**, and non-folding portion **610b**, which is adapted to fixedly mount to the vehicle body. Powerfold mirror assembly **610** is typically operated and actuatable/deactuatable from within the vehicle cabin either by a user operator switch or by a speed sensor as described in reference to the previous embodiment. In preferred form, upon activation by the driver (or by the speed sensor), folding portion **610a** pivots or folds about a fold-away axis **611** on non-folding portion **610b** from its normal extended, viewing position to a folded position wherein the rearwardly facing side of exterior mirror assembly **610** is disposed generally parallel to the side of the vehicle.

[0125] In this embodiment, a security light **616** is mounted in non-folding portion **610b** of assembly **610**. Security light **616** is of similar construction to security light **516** and, therefore, reference is made to the previous embodiment for further details thereof. In this manner, when folding portion **610a** is moved between its extended position and its folded position, security light **616** will provide a lighted security zone adjacent the vehicle which washes the side of vehicle and provides ground illumination at the cabin entrances regardless of the position of the folded portion of the mirror assembly. Therefore, pattern of light **617** projected by light module **616** remains generally stationary with respect to the vehicle and is unaffected by the repositioning of folding portion **610a** of assembly **610**.

[0126] Furthermore, as described in reference to the previous embodiments, reflective element **614** may comprise an adjustable reflective element; for example, assembly **610** may include a manual actuator or an electrical actuator or the like, as should be understood by those skilled in the art. Moreover, movement of reflective element **614** is independent of the security light **616** as security light **616** is mounted or supported independently of reflective element **614** to assembly **610**.

[0127] As best seen in FIG. 38, security light **616** is preferably substantially incorporated at non-folding portion **610b** and aerodynamically located into fixed portion **610b**. Preferably, security light **616** is incorporated into exterior mirror assembly **610** with minimum protrusion into the slipstream of the mirror assembly. In this manner, security light **616** does not significantly impact and, preferably, does not add to the aerodynamic drag of exterior mirror assembly **610**. Most preferably, security light **616** is located into fixed portion **610b** with its security light lens **624** substantially flush with the outer surface **620** of folding portion **610b**. Furthermore, in preferred form at least security light **616**, or its light source **620**, is serviceable.

[0128] With regard to embodiments of this present invention that utilize a security light module incorporated in a powerfold exterior mirror assembly where the security light is located in the folding portion of the powerfold assembly, the optical design of the light module can be such that a pattern of ground illumination is provided, such as is illustrated in FIGS. 11 and 12, and where the side of the vehicle and the entrances/exits of the cabin are well illuminated, when the folding portion of the powerfold assembly is retracted and folded to the side of the vehicle body. Alternately, the preferred patterns of FIGS. 11 and 12 can be realized when the folding portion is extended to its outward, non-retracted posi-

tion. In this regard, it is optionally desirable that the folding portion, if retracted and folded to the vehicle body when the driver approaches the vehicle from a distance, can be remotely unfolded such as by providing a button on a hand held transmitter (such as a keyfob, commonly provided to vehicle owners today for remote lock/unlock of vehicle doors) which, when actuated, transmits a signal, preferably a radio frequency (RF) signal or an infrared (IR) signal, to a receiver in the vehicle of which, upon receipt of the remote command, causes the powerfold assembly to unfold and move its folding portion to the fully extended, normal driving, unfolded position. Simultaneously, the security light can be activated so that when the powerfold unit unfolds, the signal light therein illuminates, and with both features being actuated by remote actuation from a distance. Such feature or features can be blocked out, as described previously, to avoid inadvertent operation when the vehicle is in motion.

[0129] The concepts of this invention are applicable to a variety of exterior vehicular mirror assembly constructions, including one-part designs, uni-body constructions, and their like, as known in the exterior mirror assembly art. The concepts of the invention are applicable to a variety of assemblies including assemblies that use a bracket as a distinct internal structure and assemblies that do not use a bracket but rather are bracket-less assemblies where the housing itself serves as a structural element with means such as on the walls of the housing for securing an actuator and for receiving a lamp module.

[0130] Also, although desirably and preferably finding utility as a security light, the exterior mirror assembly light modules of this invention are also useful for other purposes such as providing for a courtesy exterior light and a general ground illumination light when such lighting may be desired such as when a door is opening, a key is inserted, or a key-board entry is touched, or when approach of a person to a vehicle is detected such as by voice activation, proximity detection and their like. Also, light modules using the principles and concepts described herein could be provided for mounting on the vehicle other than within an exterior mirror assembly, such as under a door within a door well or under a door body panel so as to provide ground illumination directly under a door whenever said door is opened.

[0131] While several forms of the invention have been shown and described, other forms will now become apparent to those skilled in the art. For example, the signal light assembly (**216**, **316**, or **416**) may project a white light or other colored light including a red light or a blue light (such as could be generated by a blue LED or blue phosphor). Likewise, the security light module (**516** or **616**) may project a colored light, such as an amber light or a red light as desired. Furthermore, as described in reference to the first embodiment, rearview mirror assemblies **310**, **410**, **510** or **610** may comprise fixed position mirror assemblies or break-away mirror assemblies. Changes and modification in the specifically described embodiments can be carried out without departing from the principles of the invention, which is intended to be limited only by the scope of the appended claims, as interpreted according to the principles of patent law including the doctrine of equivalents. Therefore, it will be understood that the embodiment shown in the drawings described above are merely for illustrated purposes only and are not intended to limit the scope of the invention which is defined by the claims that follow.

We claim:

- 1. An exterior rear view mirror assembly comprising:
 - a housing;
 - a reflective mirror supported by the housing and arranged in a rearwardly facing direction;
 - a support member having an outboard end attached to the housing and an inboard end secured to an outer surface of a motor vehicle, the support member including an opening; and
 - a light transmitting lens disposed in the opening of the support member, the lens enabling light to project from an interior of the support member to an exterior of the support member to illuminate a predetermined area in proximity to the motor vehicle.
- 2. The apparatus of claim 1 further comprising a light assembly including a housing having a light source therein, the light assembly housing being secured within the support member and the light source being operable to generate a light for projection through the lens.
- 3. The apparatus of claim 1 further comprising:
 - a light assembly including a housing having a light source therein, the light assembly housing being secured within the motor vehicle and the light source being operable to generate a light for projection through the lens; and
 - a light path traversing between the lens and the light assembly housing, the light path transporting light between the light source and the lens.
- 4. The apparatus of claim 3 wherein the light path includes a reflective element for reflecting light from the light source in the direction of the lens.
- 5. The apparatus of claim 3 further comprising a sail formed integrally with the support member, the sail securing the support member to the motor vehicle.
- 6. The apparatus of claim 1 further comprising a sail formed integrally with the support member for securing the support member to the motor vehicle.
- 7. The apparatus of claim 1 further comprising:
 - a light assembly including a housing having a light source therein, the light assembly housing being secured within the motor vehicle and the light source being operable to generate a light for projection through the lens; and
 - a light path integrally formed in the support member and traversing between the lens and the light assembly housing, the light path transporting light between the light source and the lens.
- 8. An exterior rear view mirror assembly comprising:
 - a housing;
 - a reflective mirror supported by the housing and arranged in a rearwardly facing direction;

- a support member having an outboard end attached to the housing and an inboard end secured to an outer surface of a motor vehicle, the support member including an opening;
 - a sail attached to the inboard end of the support member, the sail securing the support member to the motor vehicle; and
 - a light transmitting lens disposed in the opening of the support member, the lens enabling light to project from an interior of the support member to an exterior of the support member to illuminate a predetermined area in proximity to the motor vehicle.
- 9. The apparatus of claim 8 further comprising a light assembly including a housing having a light source therein, the light assembly housing being secured within the support member and the light source being operable to generate a light for projection through the lens.
 - 10. The apparatus of claim 8 further comprising:
 - a light assembly including a housing having a light source therein, the light assembly housing being secured within the motor vehicle and the light source being operable to generate a light for projection through the lens; and
 - a light path traversing between the lens and the light assembly housing, the light path transporting light between the light source and the lens.
 - 11. The apparatus of claim 10 wherein the light path includes a reflective element for reflecting light from the light source in the direction of the lens.
 - 12. The apparatus of claim 8 wherein the lens forms a smooth contour in the opening.
 - 13. The apparatus of claim 8 further comprising:
 - a light assembly including a housing having a light source therein, the light assembly housing being secured within the motor vehicle and the light source being operable to generate a light for projection through the lens; and
 - a light path integrally formed in the support member and traversing between the lens and the light assembly housing, the light path transporting light between the light source and the lens.
 - 14. The apparatus of claim 8 further comprising:
 - a light assembly including a housing having a light source therein, the light assembly housing being secured within the motor vehicle and the light source being operable to generate a light for projection through the lens; and
 - a light path traversing between the lens and the light assembly housing, the light path transporting light between the light source and the lens.

* * * * *