



(19) **United States**
(12) **Patent Application Publication**
Justin et al.

(10) **Pub. No.: US 2010/0057205 A1**
(43) **Pub. Date: Mar. 4, 2010**

(54) **UNIVERSAL SPINAL DISC IMPLANT SYSTEM**

filed on Sep. 26, 2005, provisional application No. 60/741,513, filed on Nov. 30, 2005.

(75) Inventors: **Daniel F. Justin**, Logan, UT (US);
Lytton A. Williams, Los Angeles, CA (US); **Darin R. Ewer**,
Providence, UT (US); **Nathan Pierce**, Millville, UT (US)

Publication Classification

(51) **Int. Cl.**
A61F 2/44 (2006.01)
A61B 17/56 (2006.01)
(52) **U.S. Cl.** **623/17.15**; 623/17.16; 606/86 R
(57) **ABSTRACT**

Correspondence Address:
MEDICINELODGE INC.
124 South 600 West
LOGAN, UT 84321 (US)

A revisable intervertebral implant may include two end plates designed to detachably receive a variety of intermediate components including articulating bearing inserts, elastic inserts, and fusion blocks. Each intermediate component may be secured to a snap insert that snaps into engagement with the corresponding end plate in response to pressure urging the intermediate component toward the end plate along a cephalad-caudal direction. The end plates may first be secured to the corresponding vertebral bodies, and then the intermediate component(s) may be snapped into locking engagement with the implanted end plates to complete in-situ assembly of the intervertebral implant. The implant may easily be revised by snapping the intermediate component(s) out of engagement with the end plates, removing the intermediate component(s), inserting the new intermediate component(s) into the space between the end plates, and snapping the new intermediate component(s) into engagement with the end plates.

(73) Assignee: **INFINITY ORTHOPAEDICS**,
Flanlinkg (HK)

(21) Appl. No.: **12/615,989**

(22) Filed: **Nov. 10, 2009**

Related U.S. Application Data

(63) Continuation of application No. 11/534,985, filed on Sep. 25, 2006, now Pat. No. 7,618,459.

(60) Provisional application No. 60/720,513, filed on Sep. 26, 2005, provisional application No. 60/720,514,

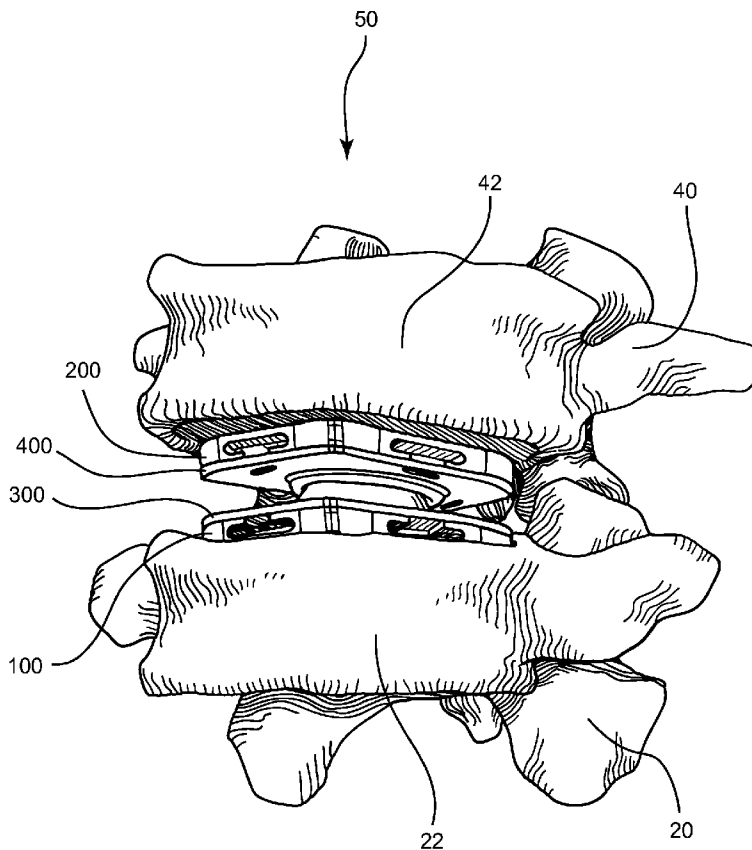

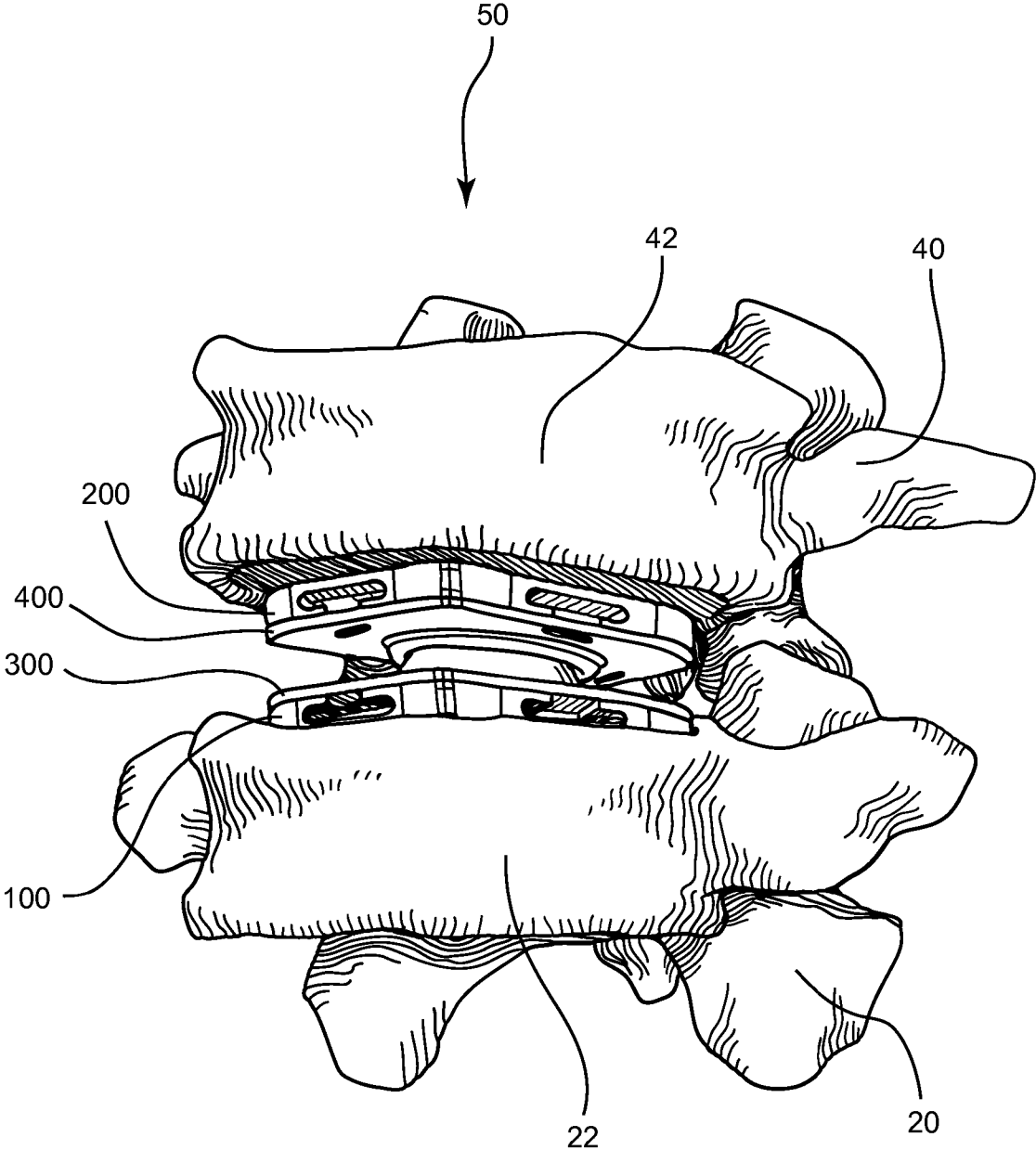

Fig. 1

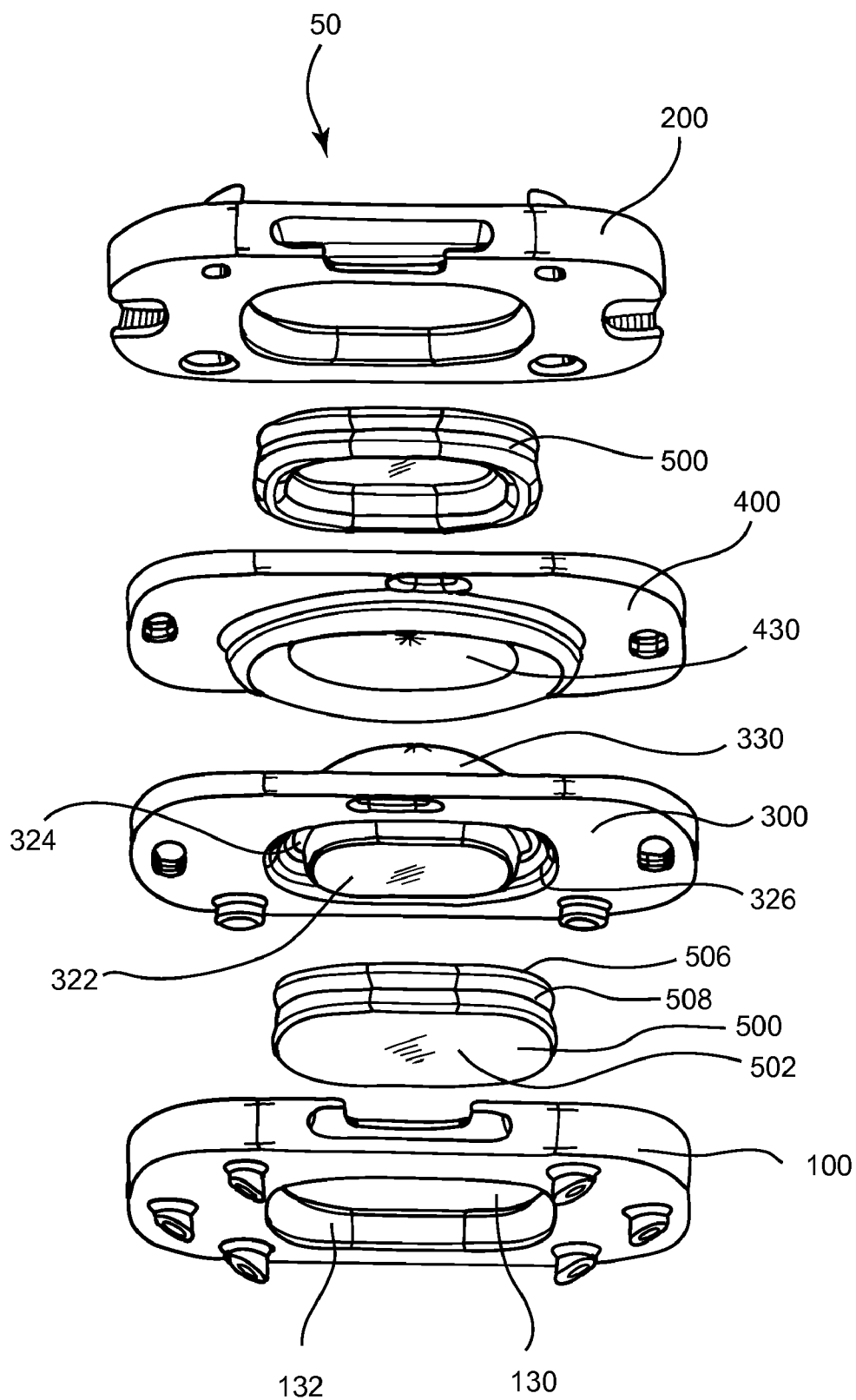

Fig. 2

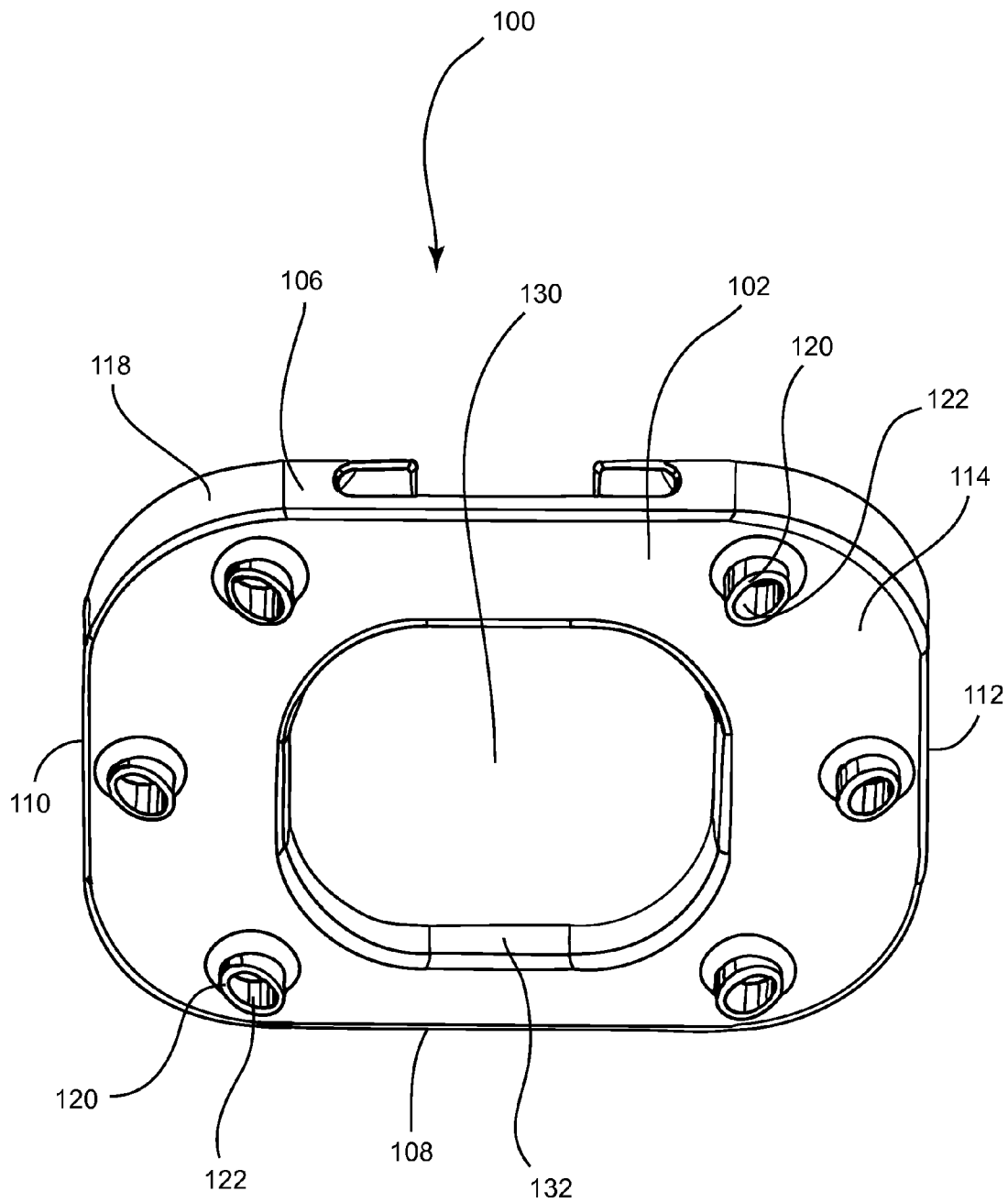

Fig. 3

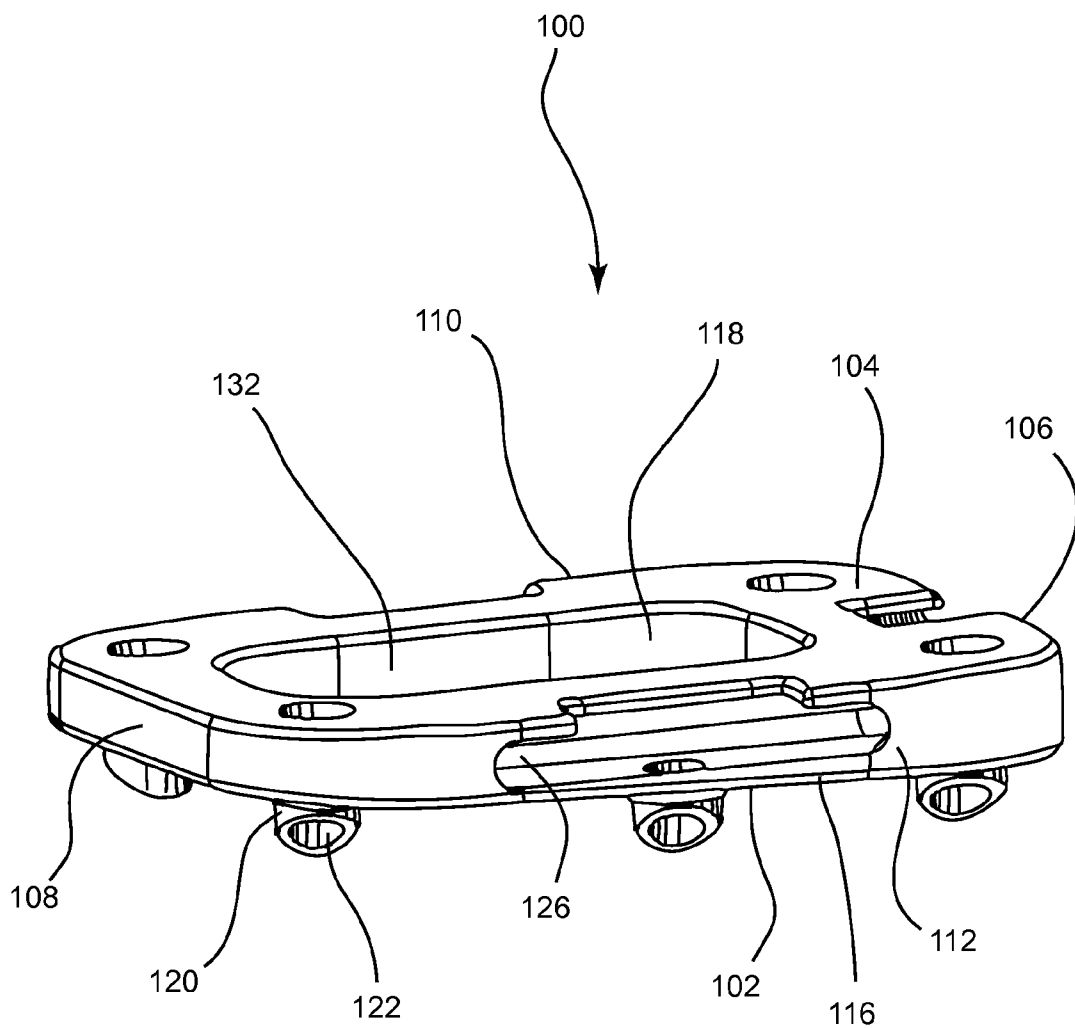

Fig. 4

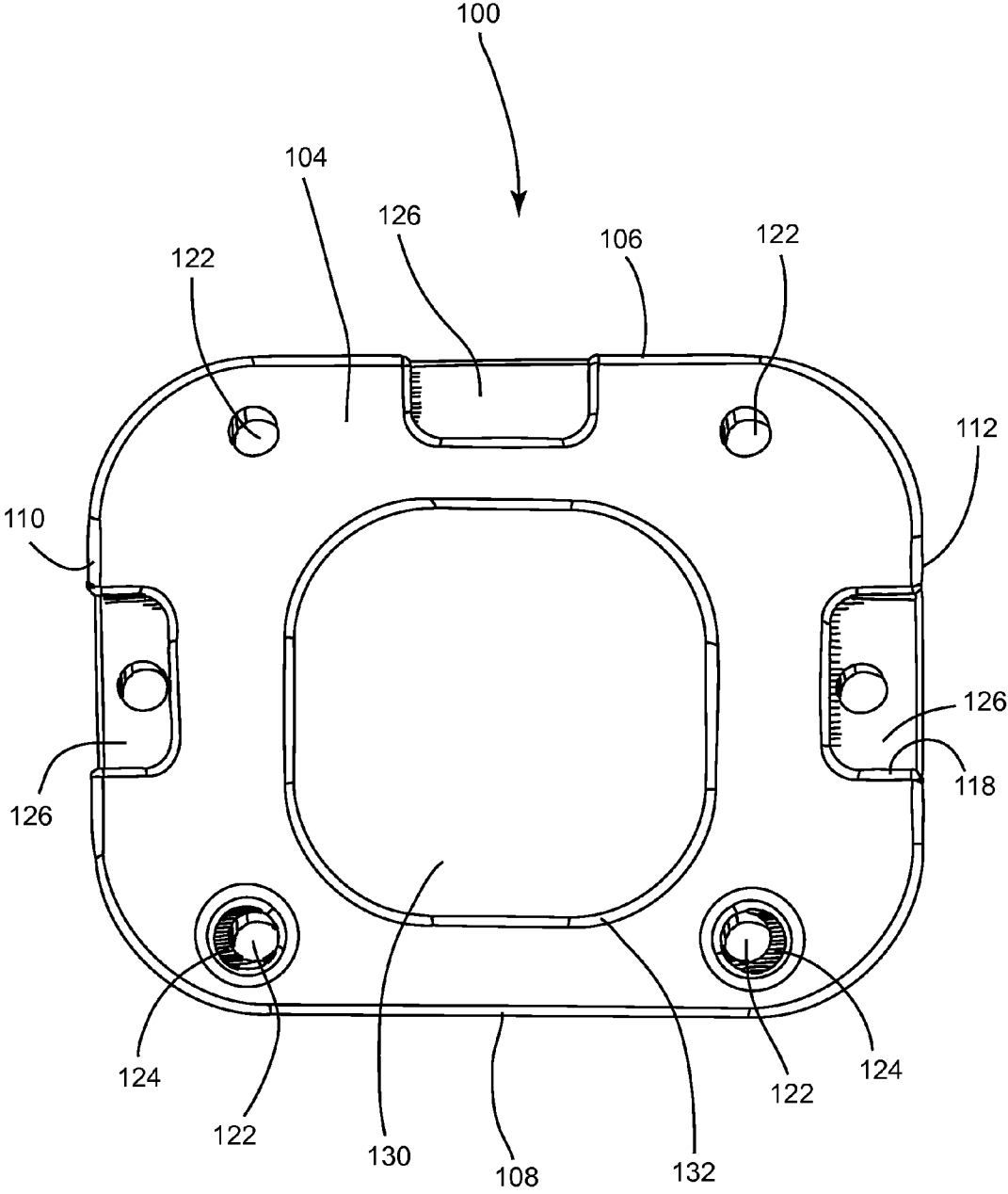

Fig. 5

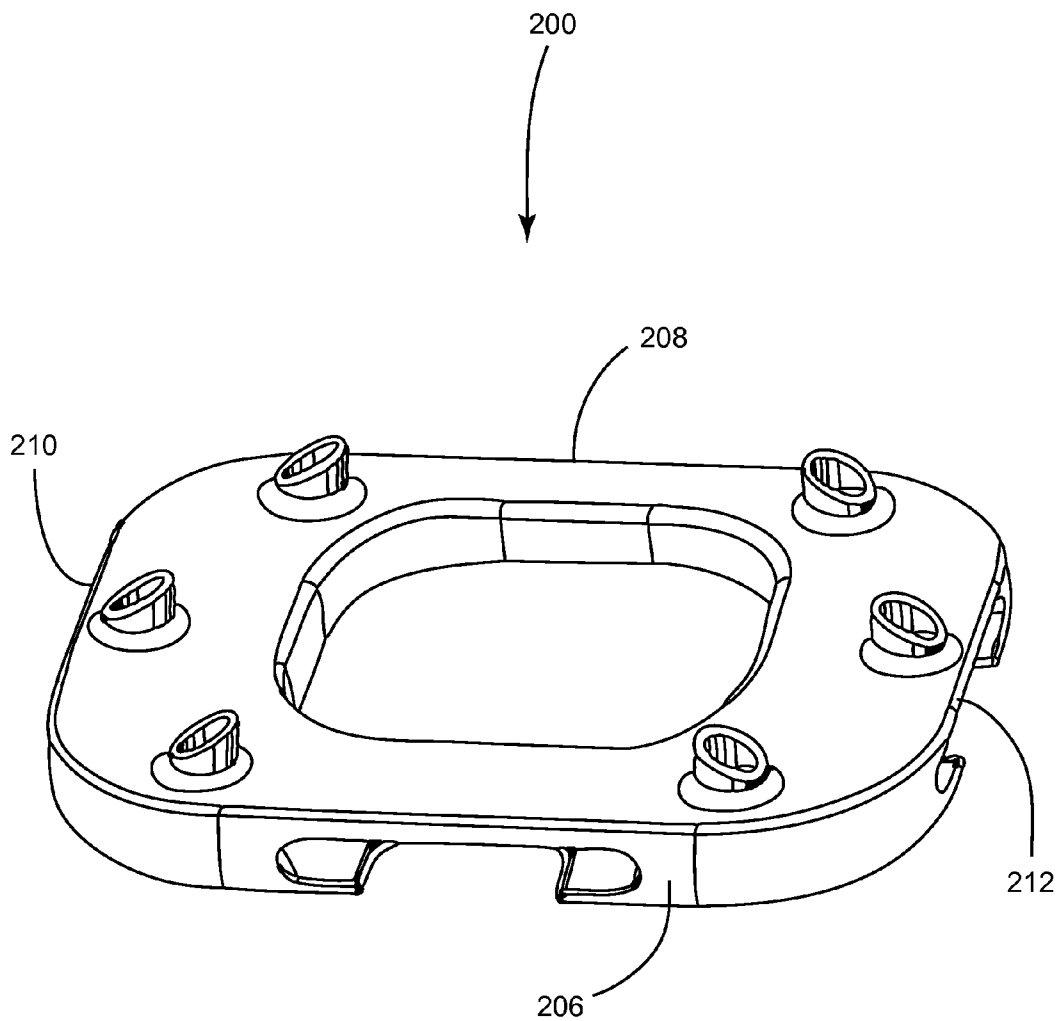

Fig. 6

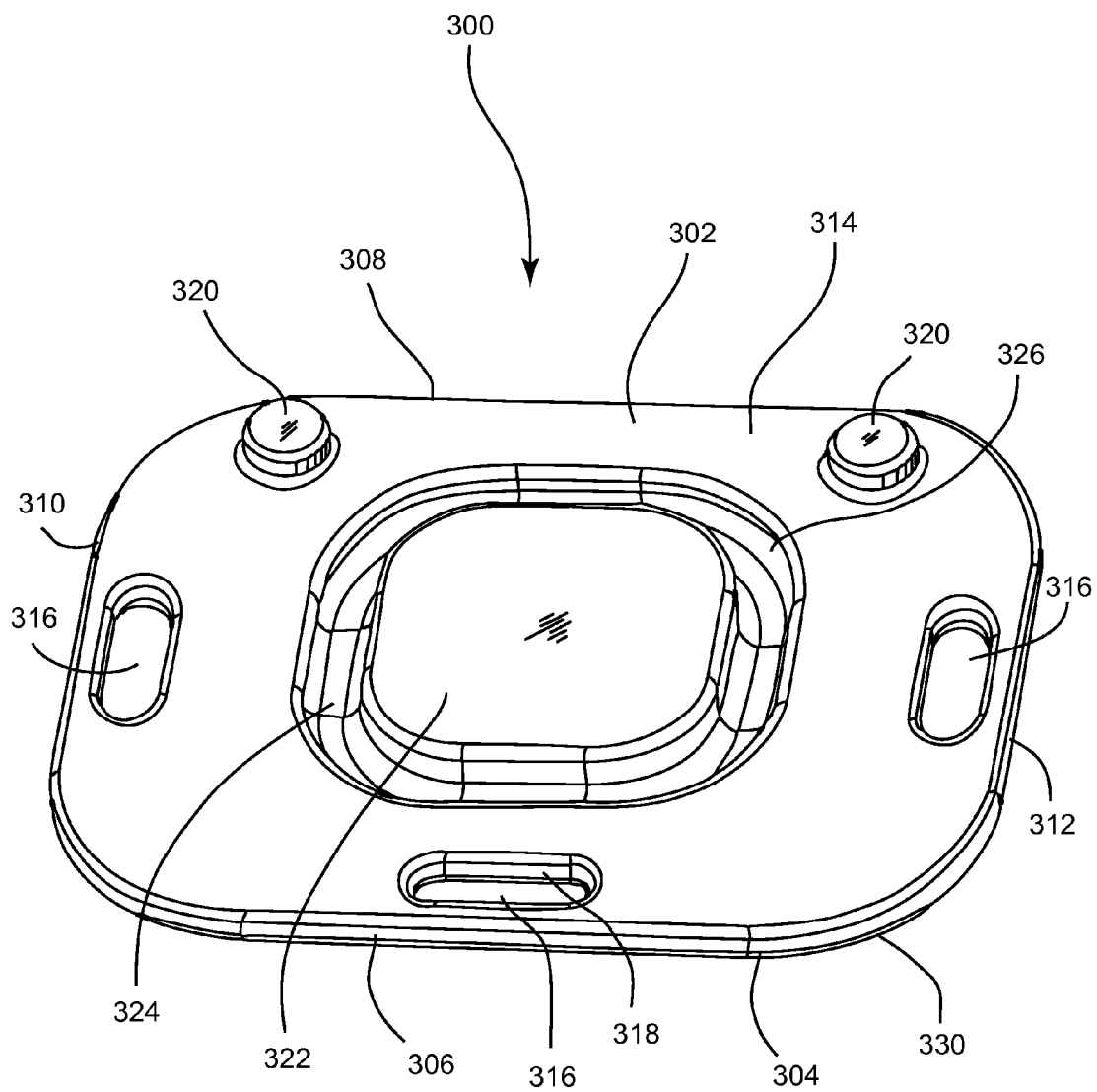

Fig. 7

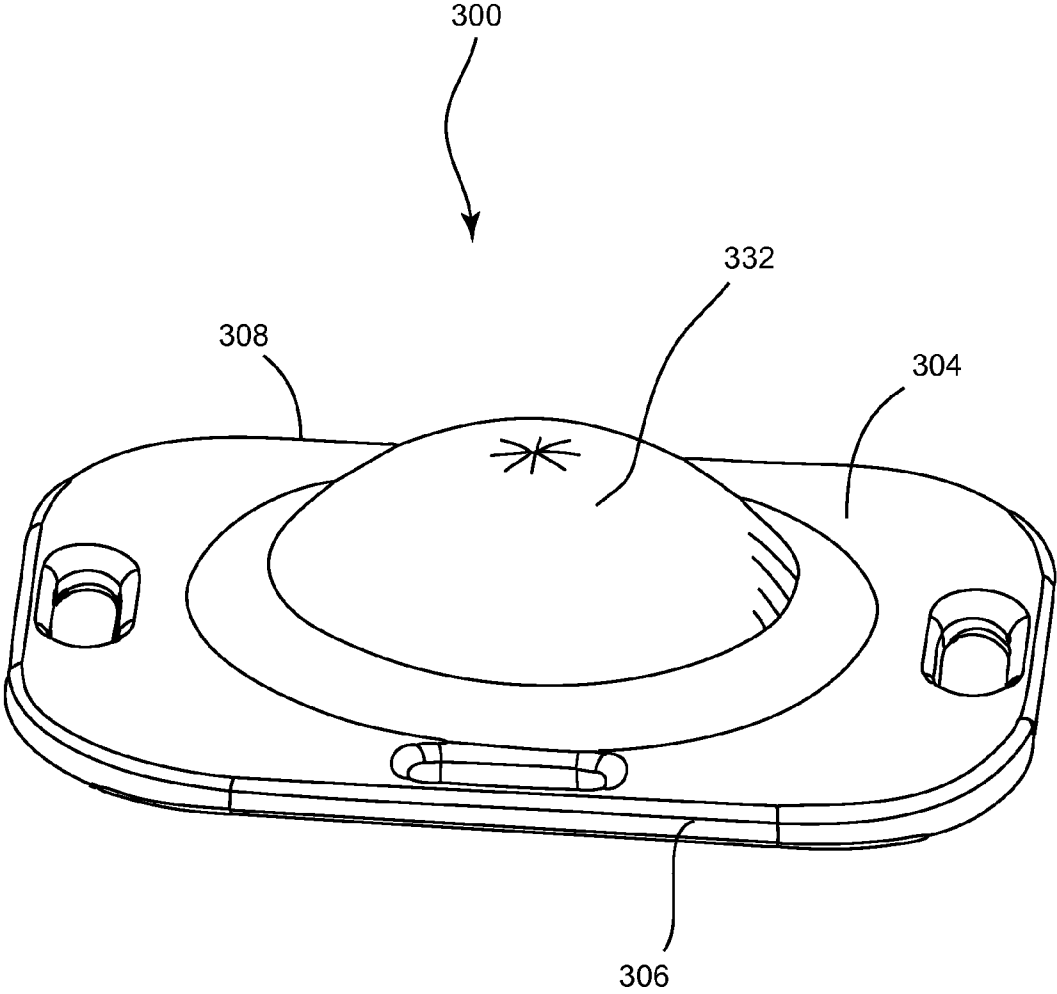

Fig. 8

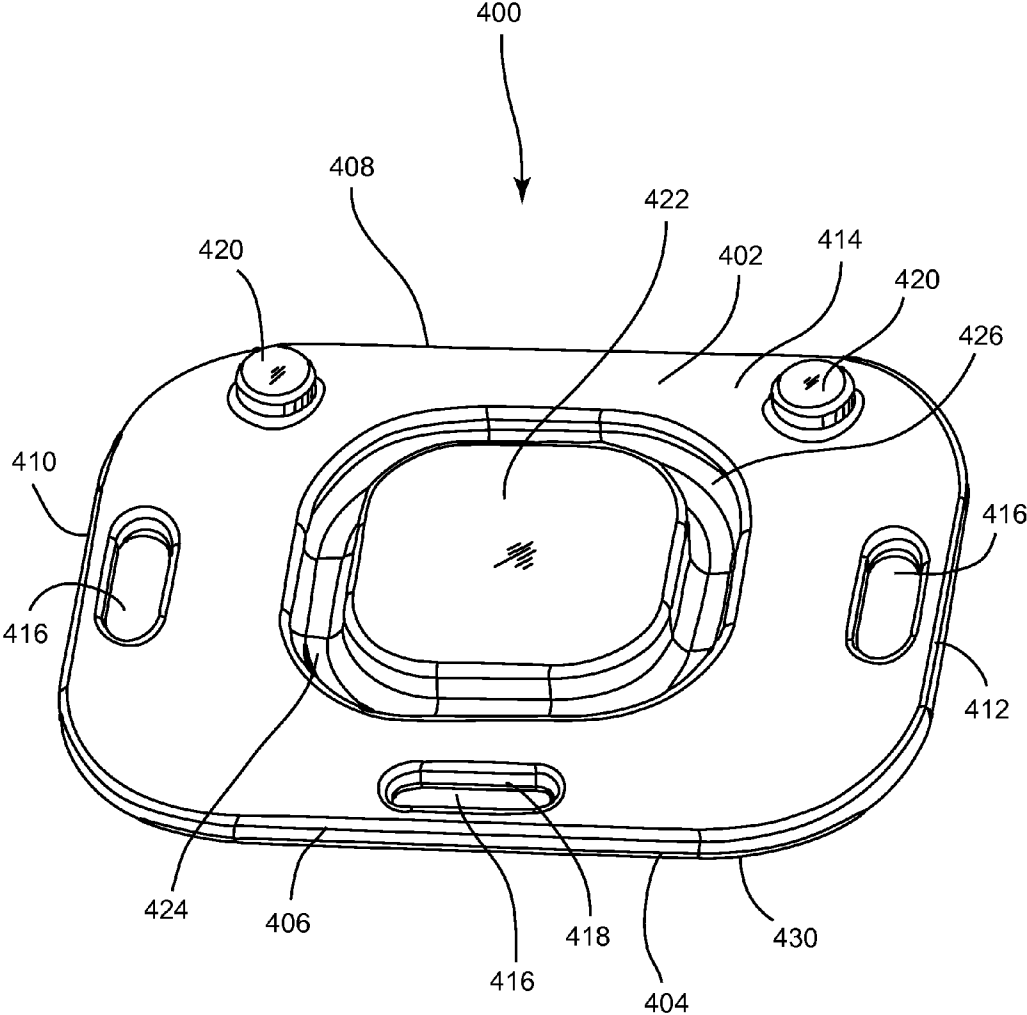

Fig. 9

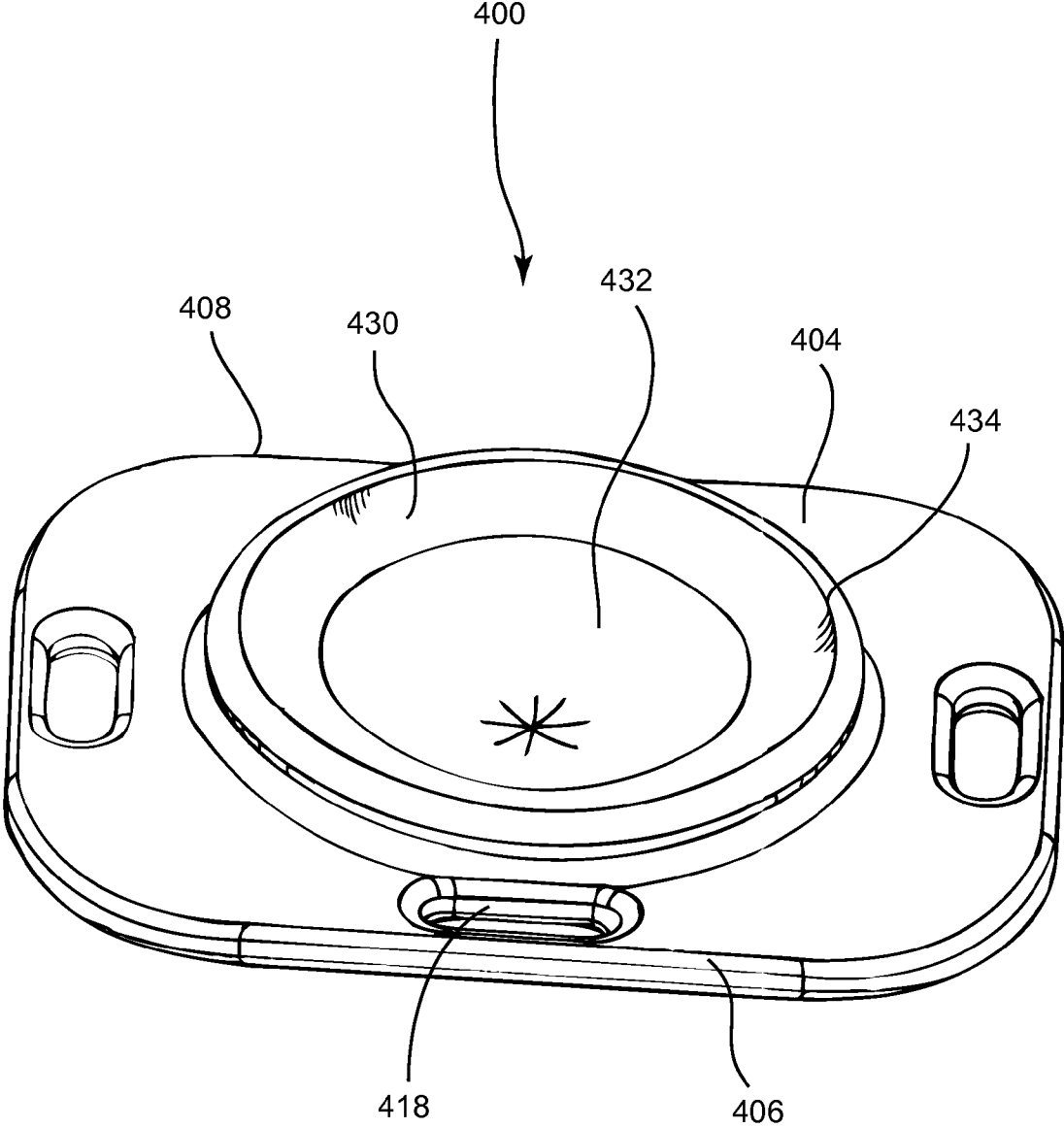

Fig. 10

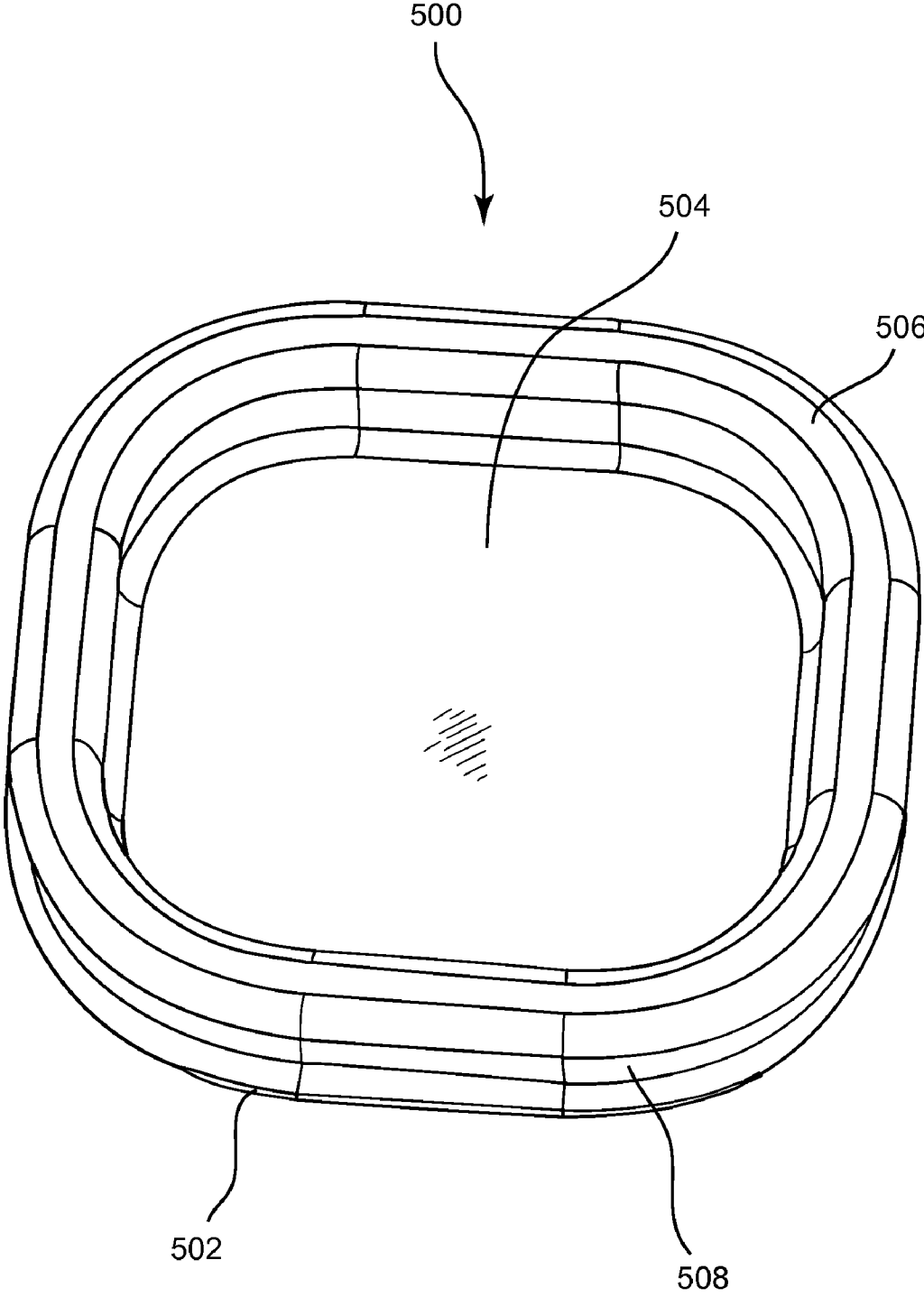

Fig. 11

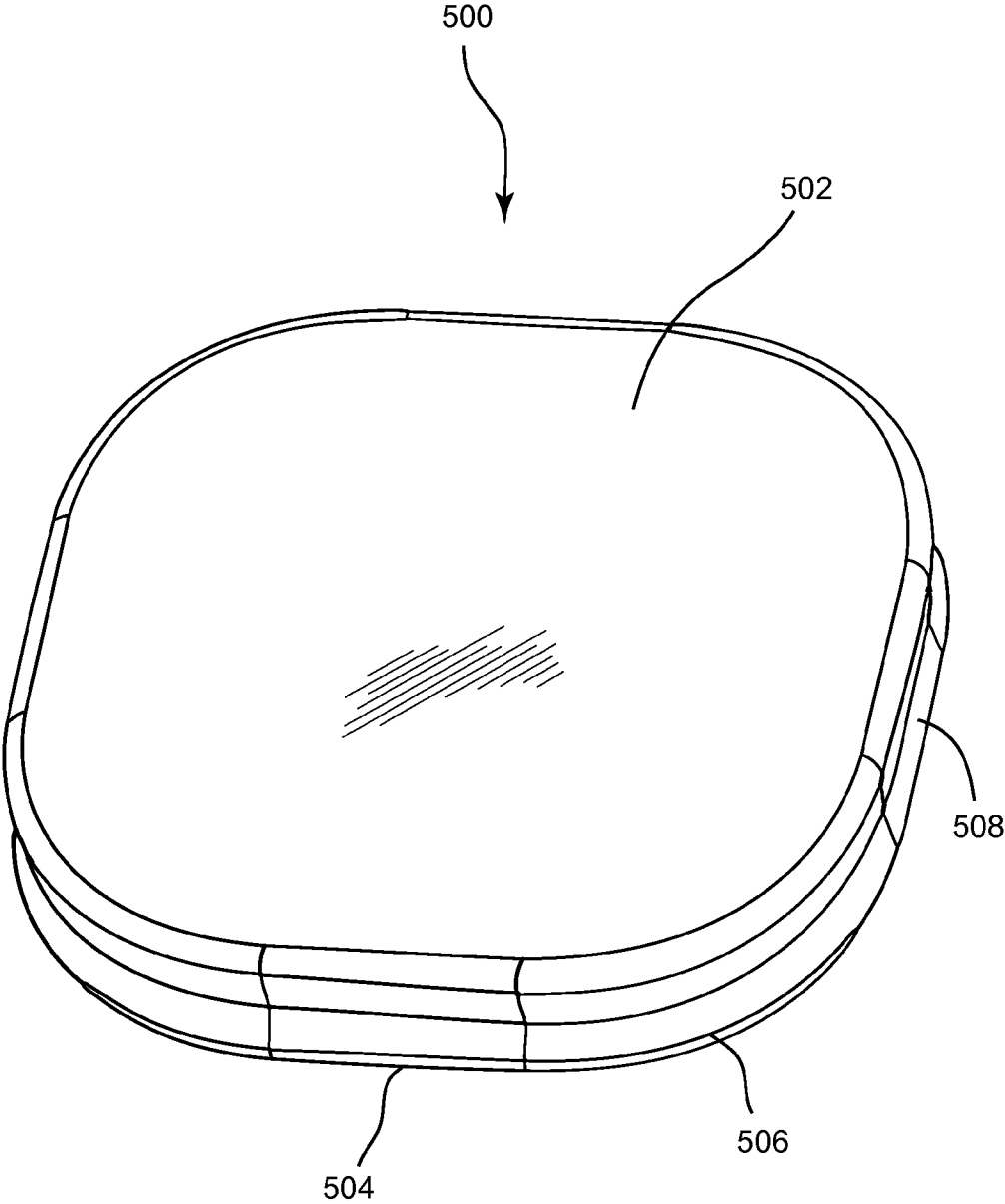

Fig. 12

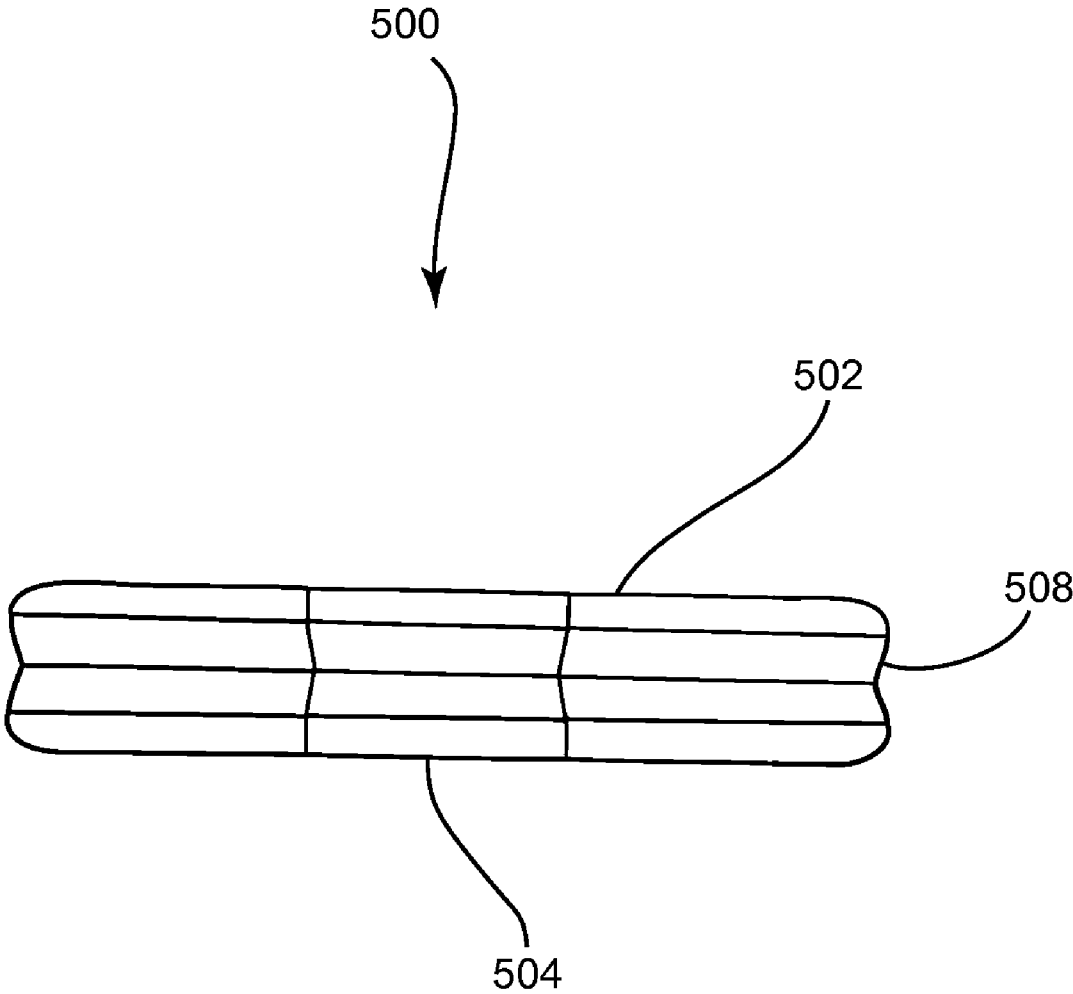

Fig. 13

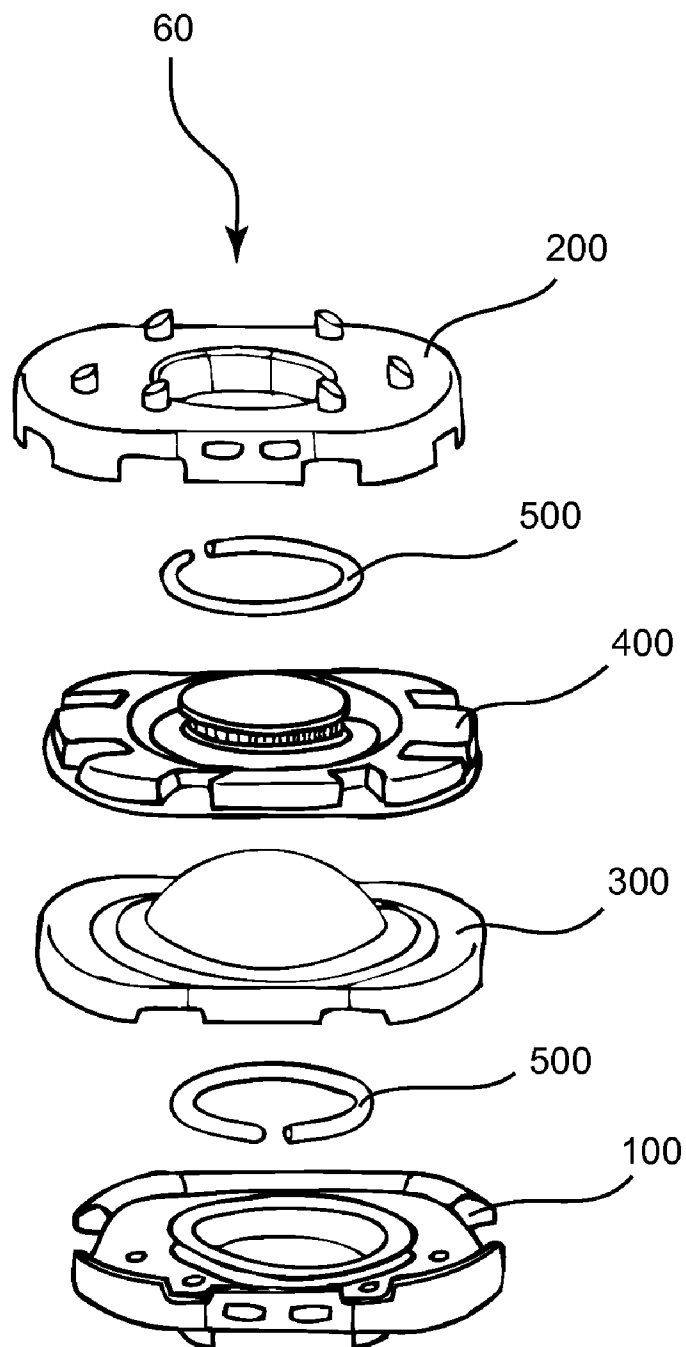

Fig. 14

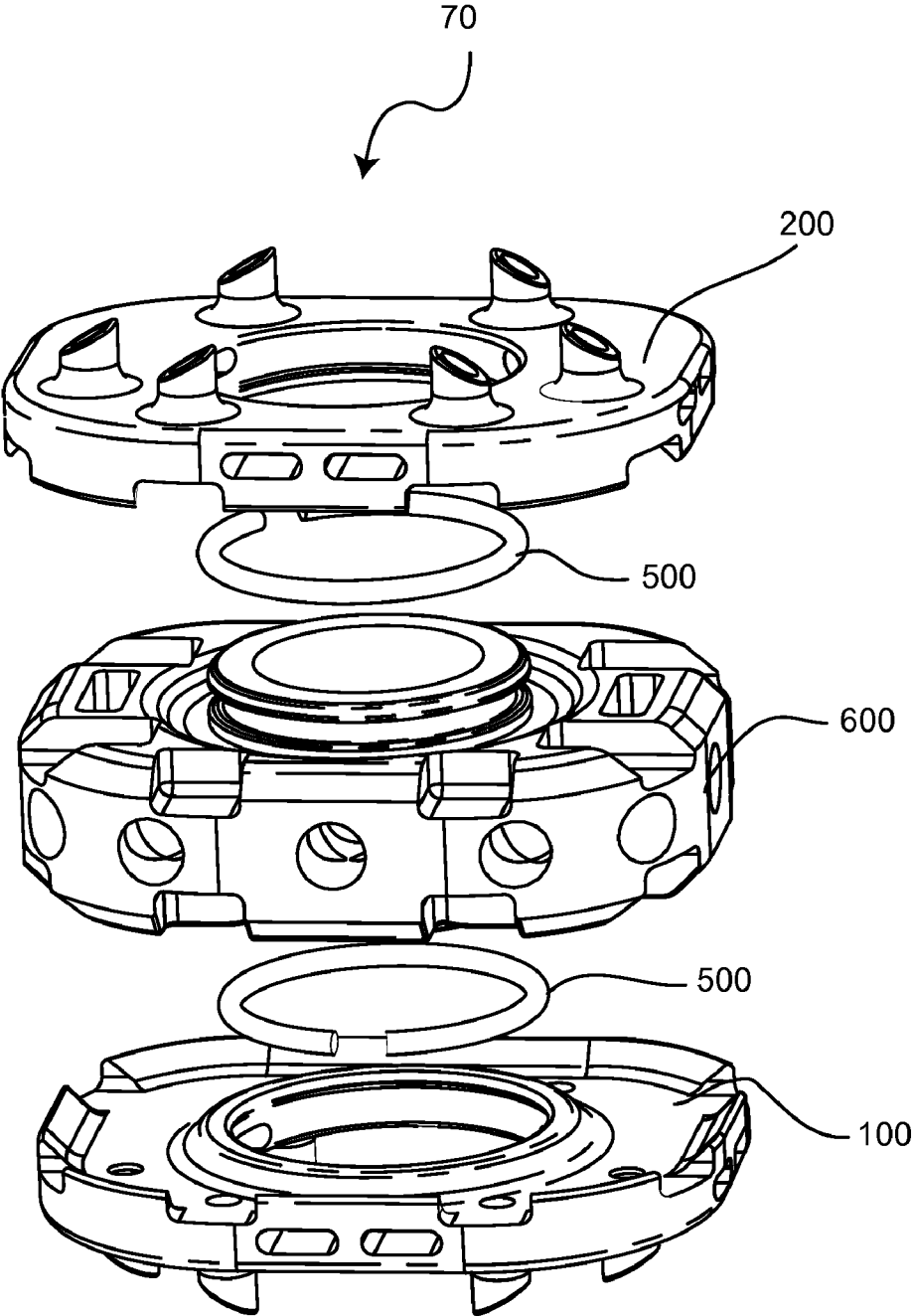

Fig. 15

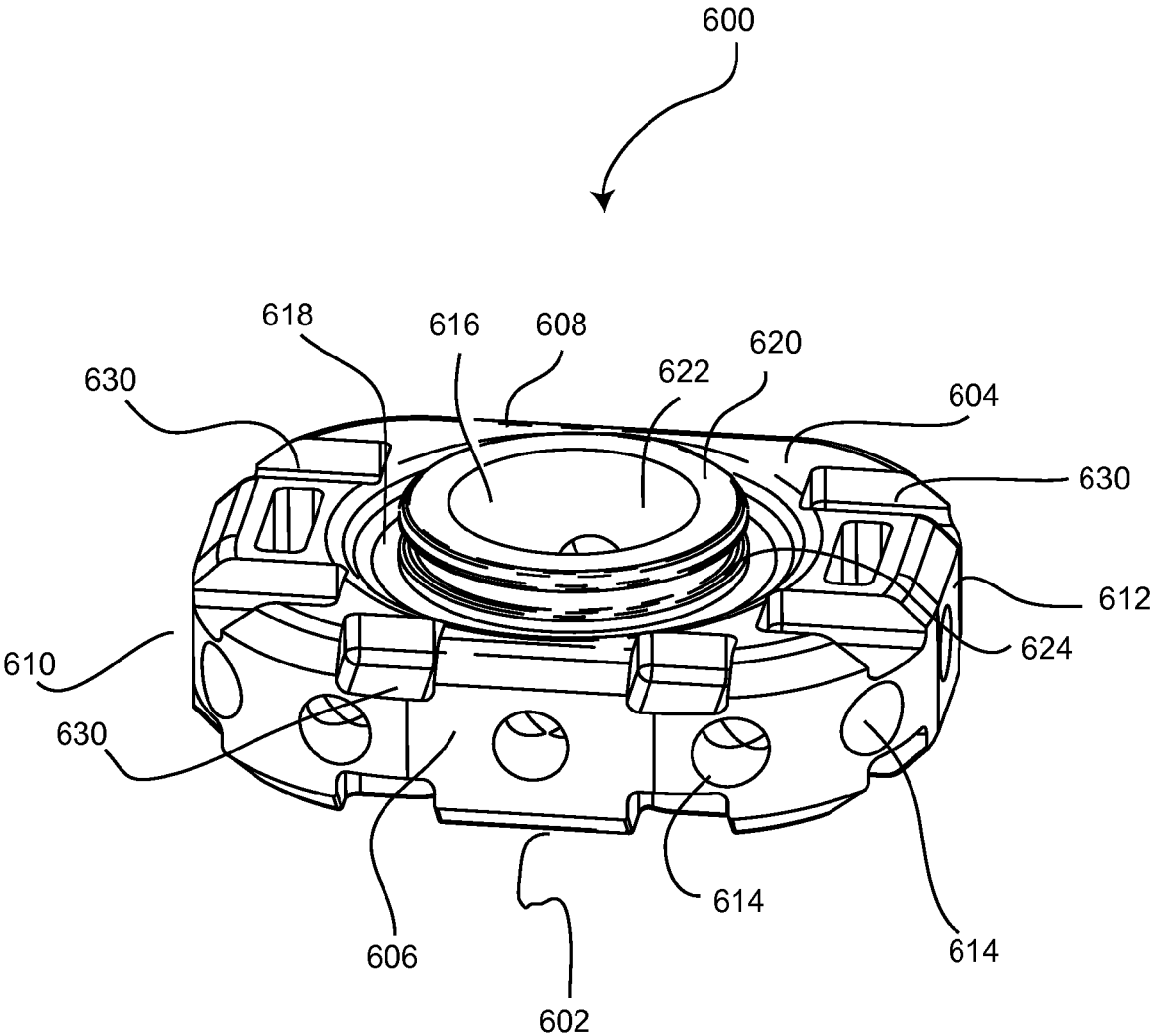

Fig. 16

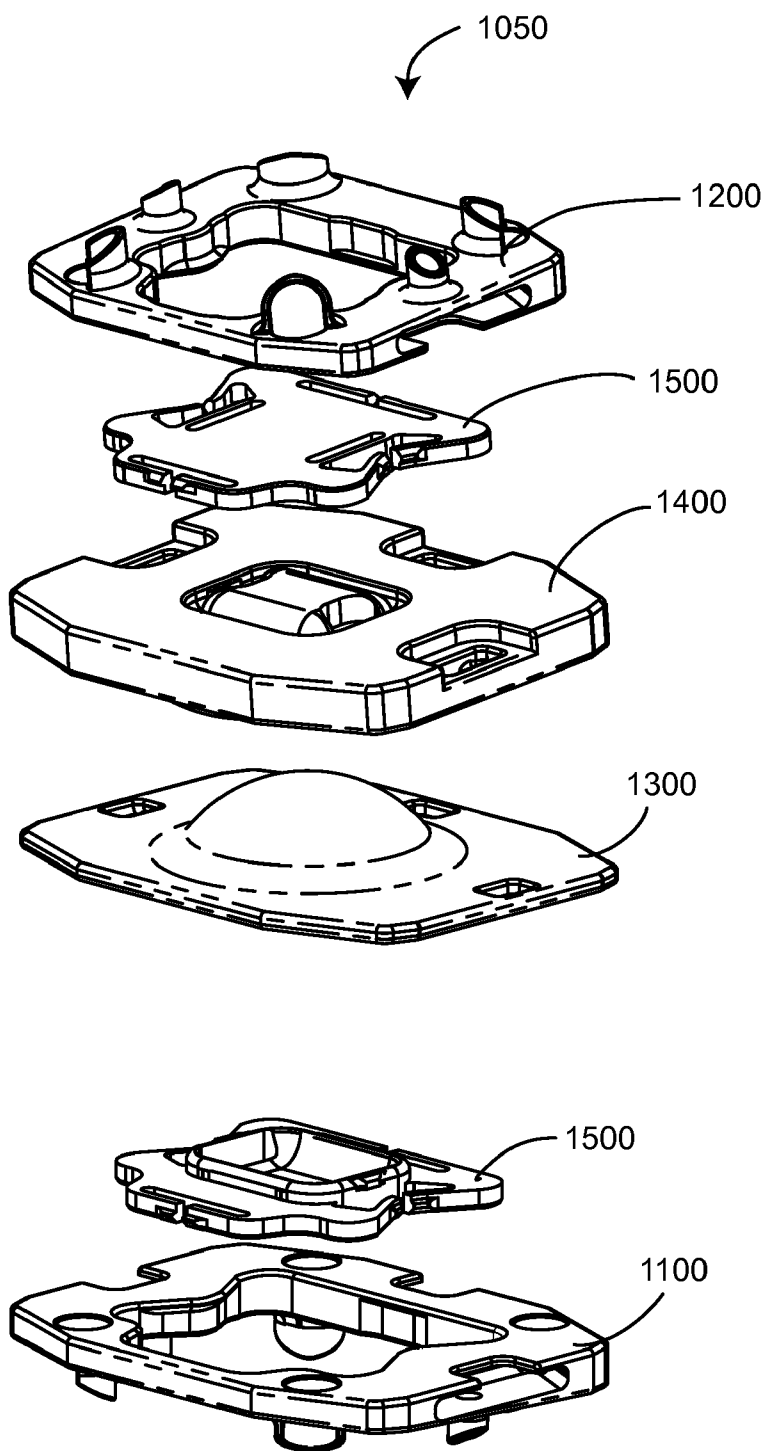

Fig 17

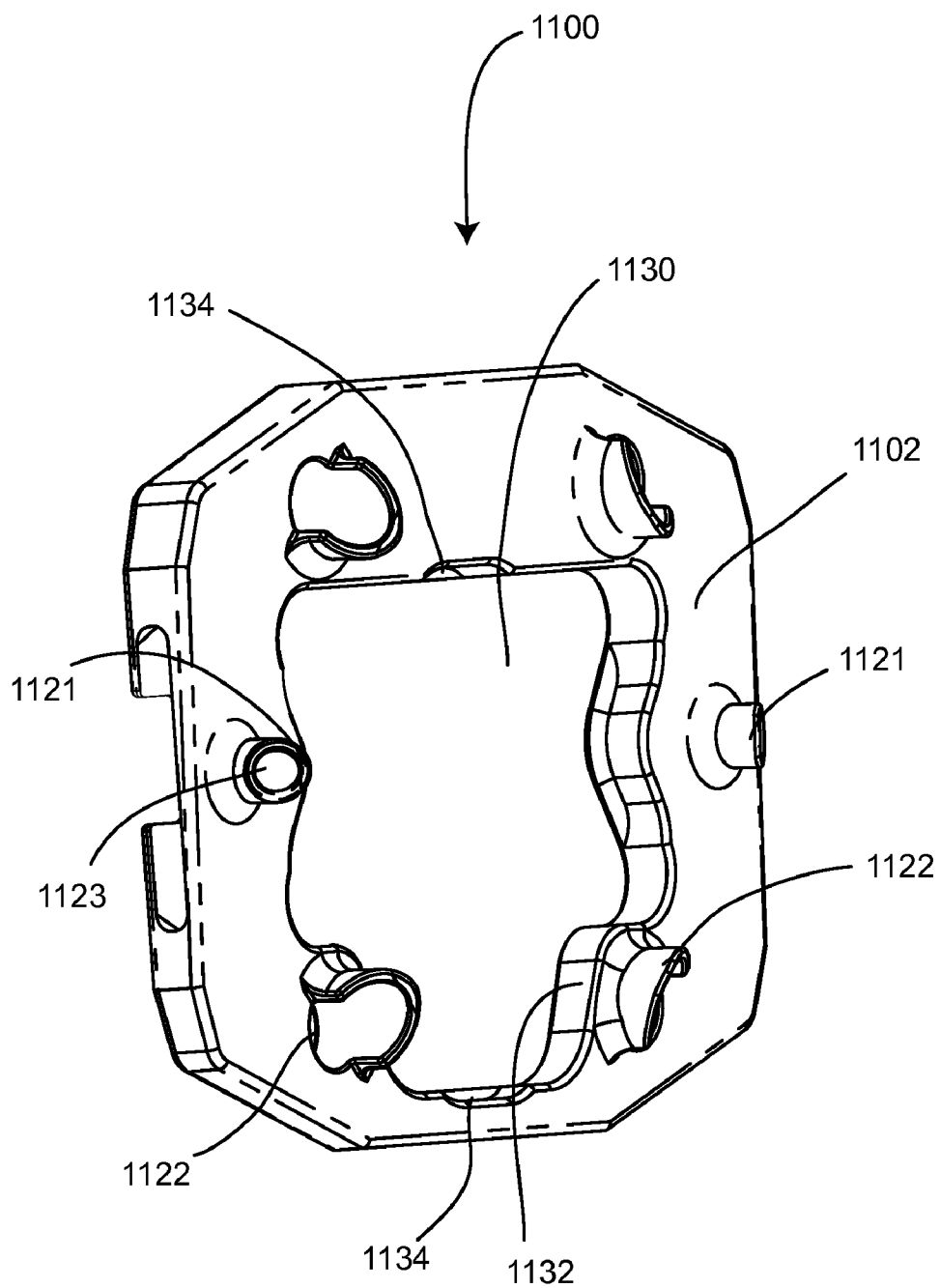

Fig. 18

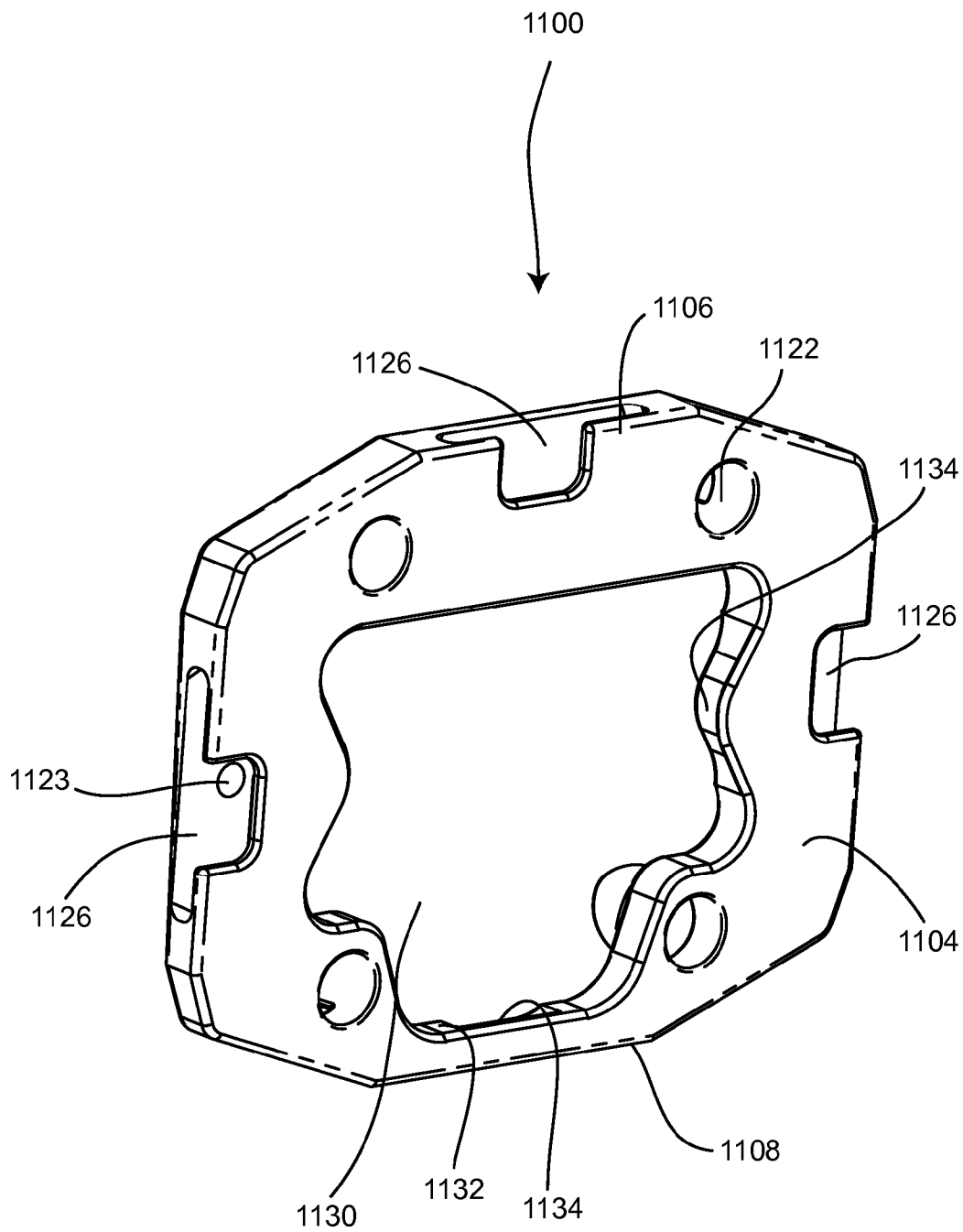

Fig. 19

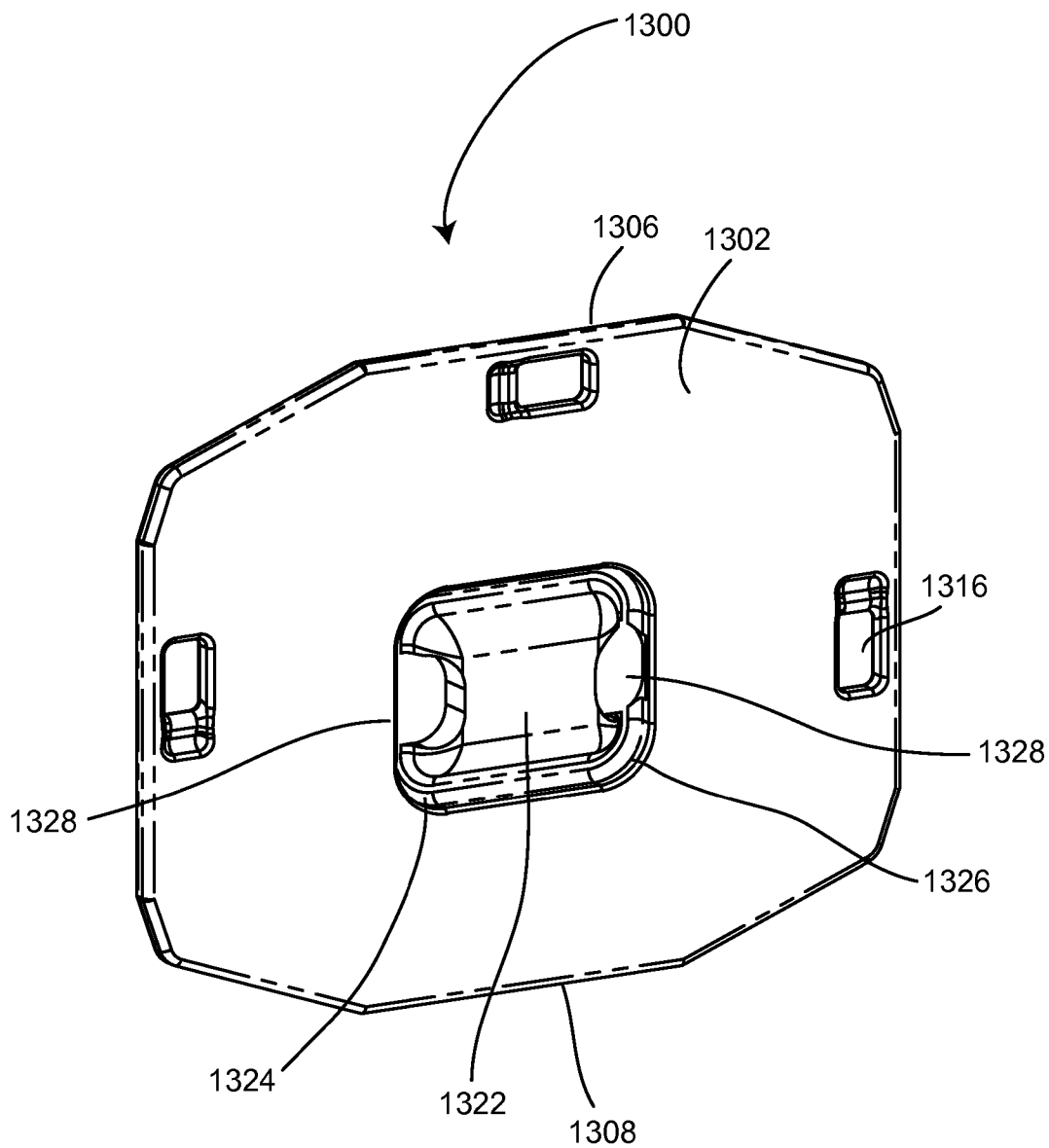

Fig. 20

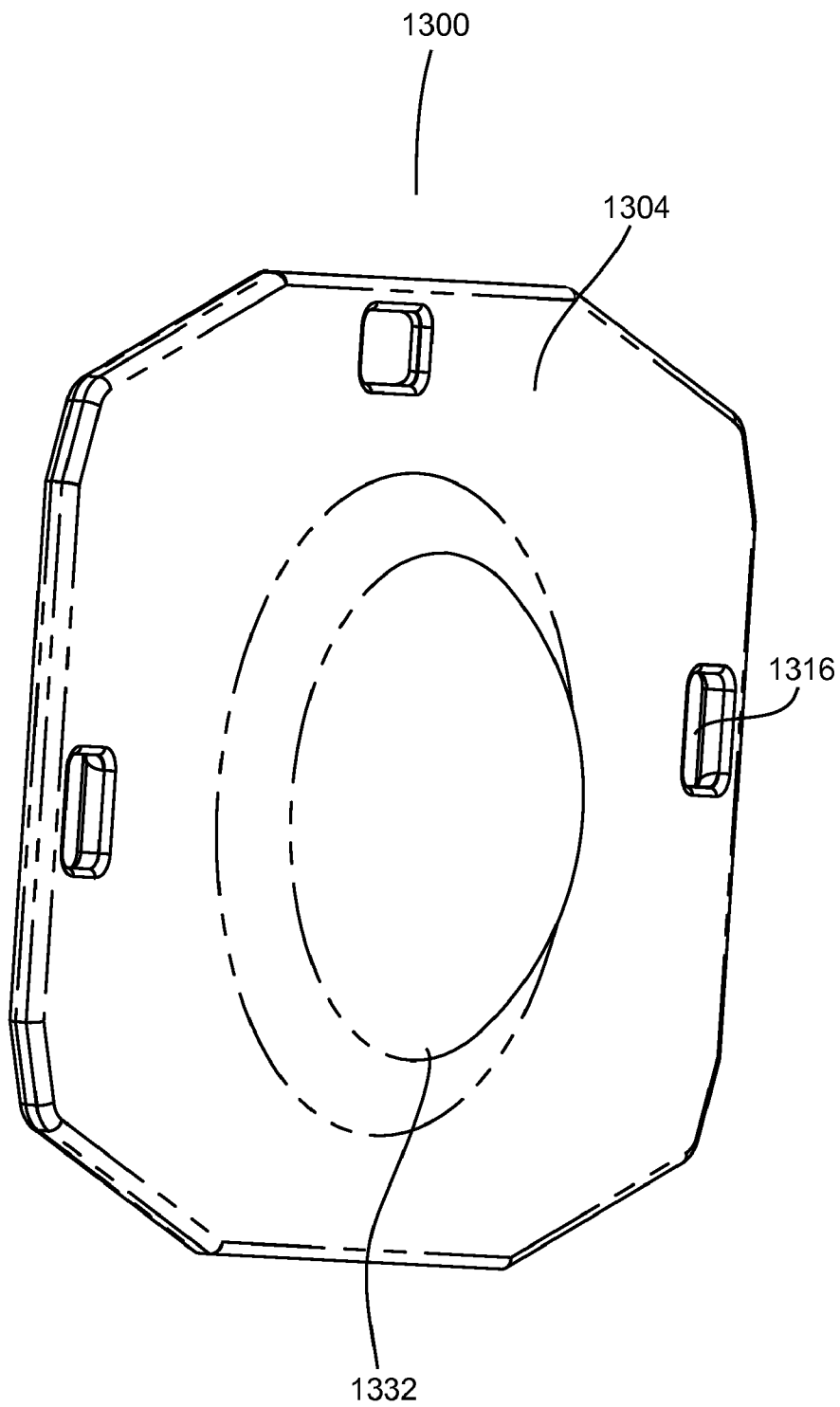

Fig. 21

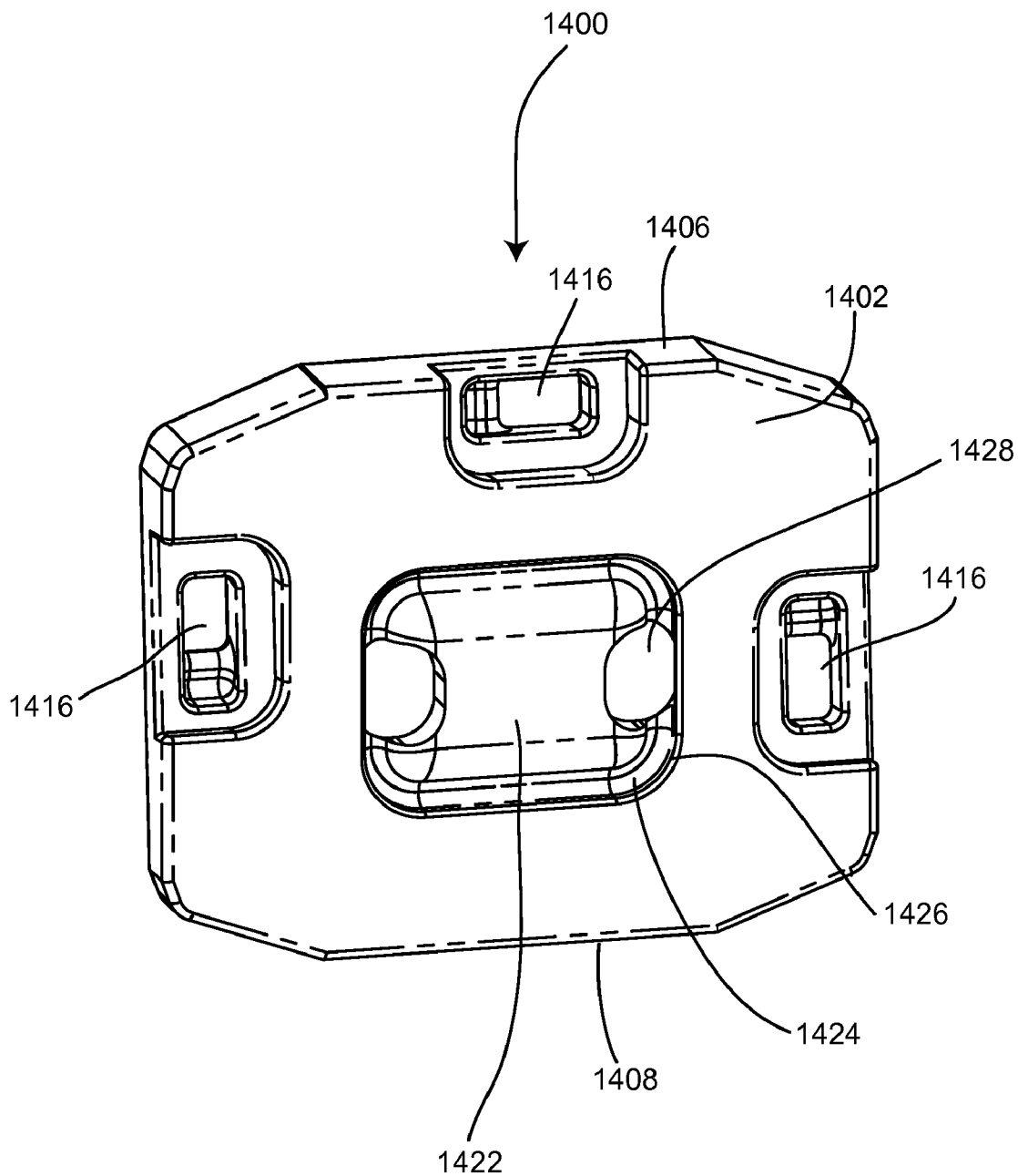

Fig. 22

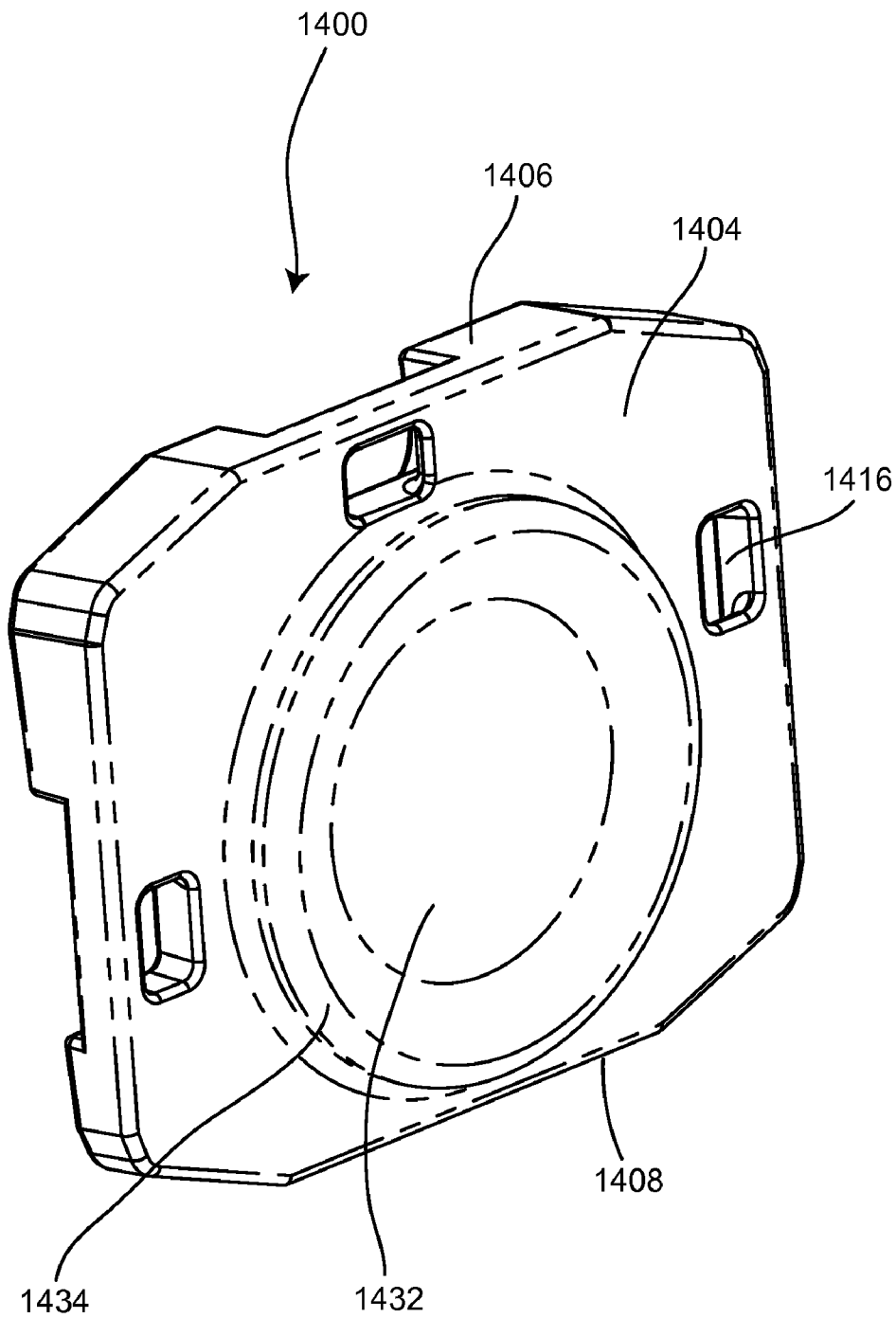

Fig. 23

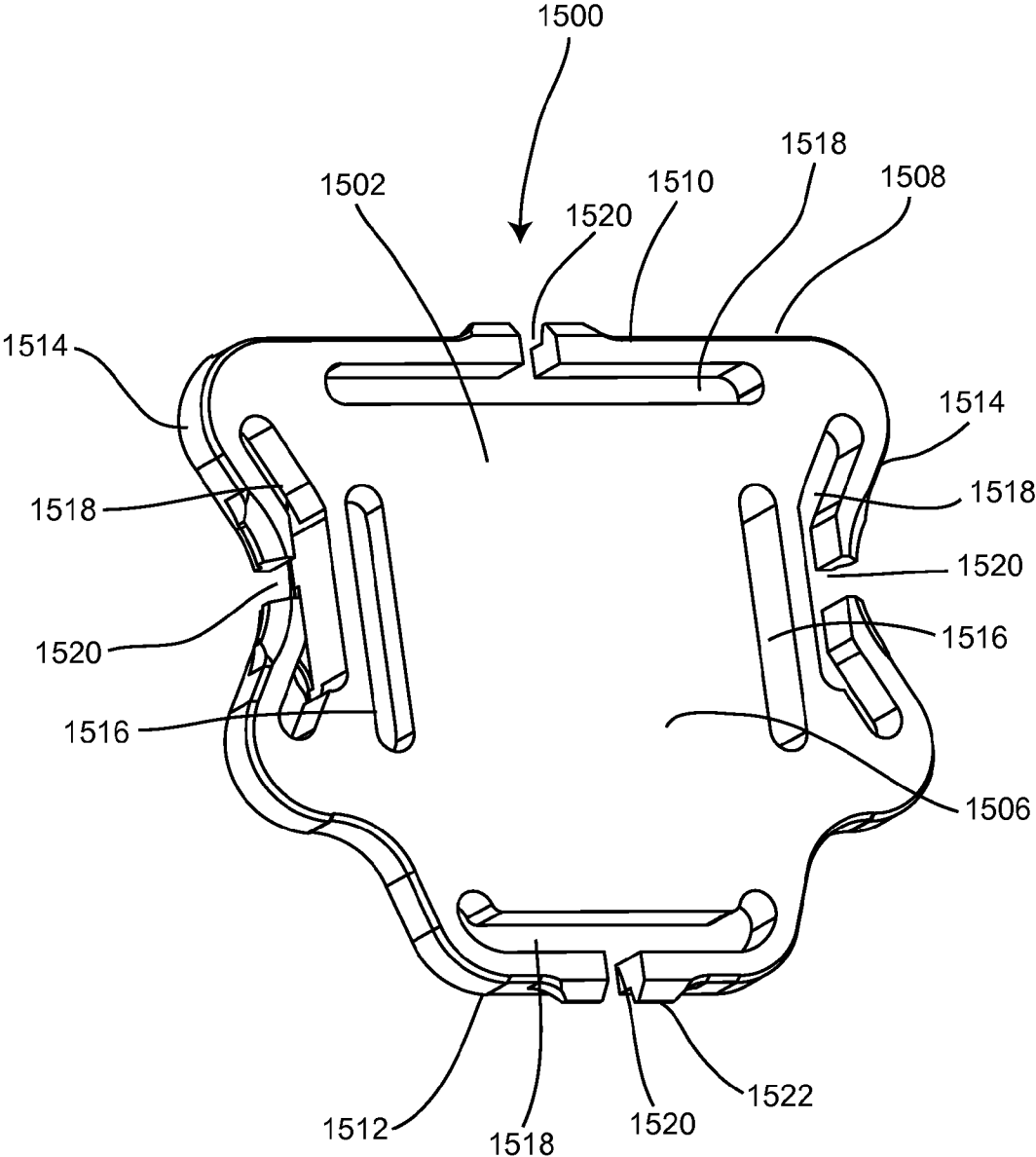

Fig. 24

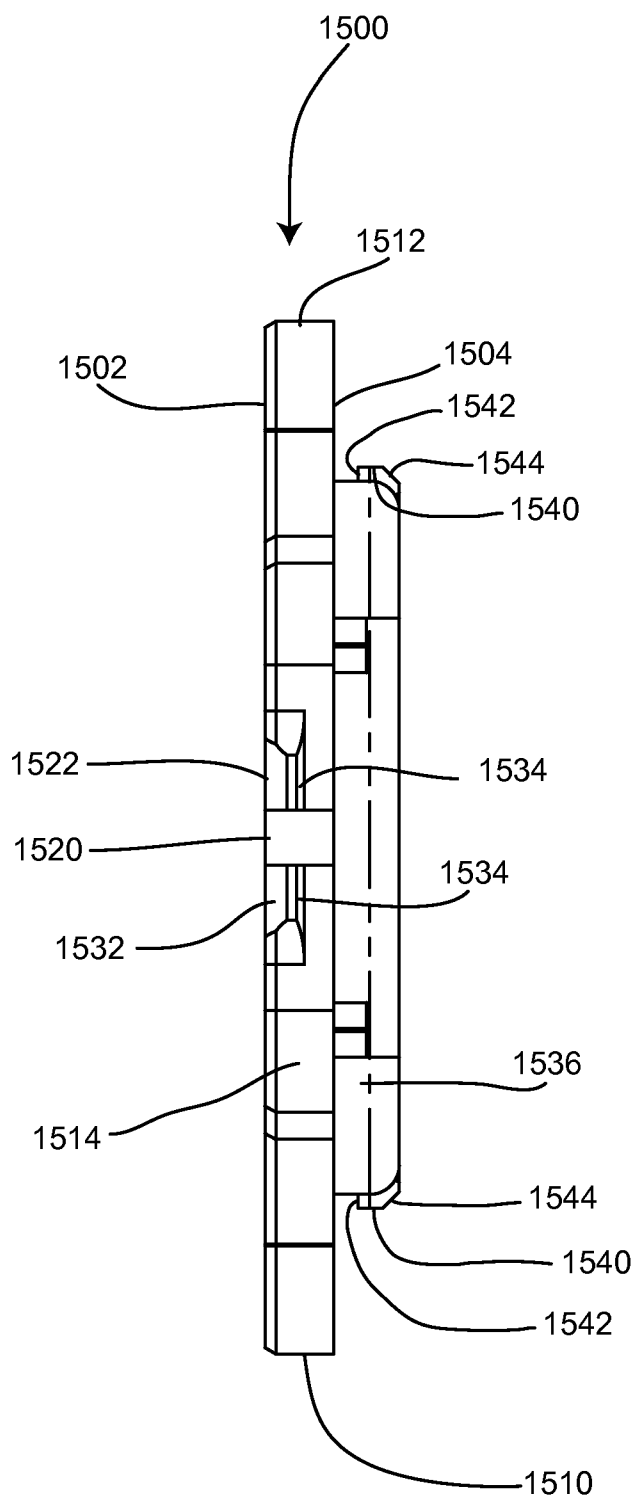

Fig. 25

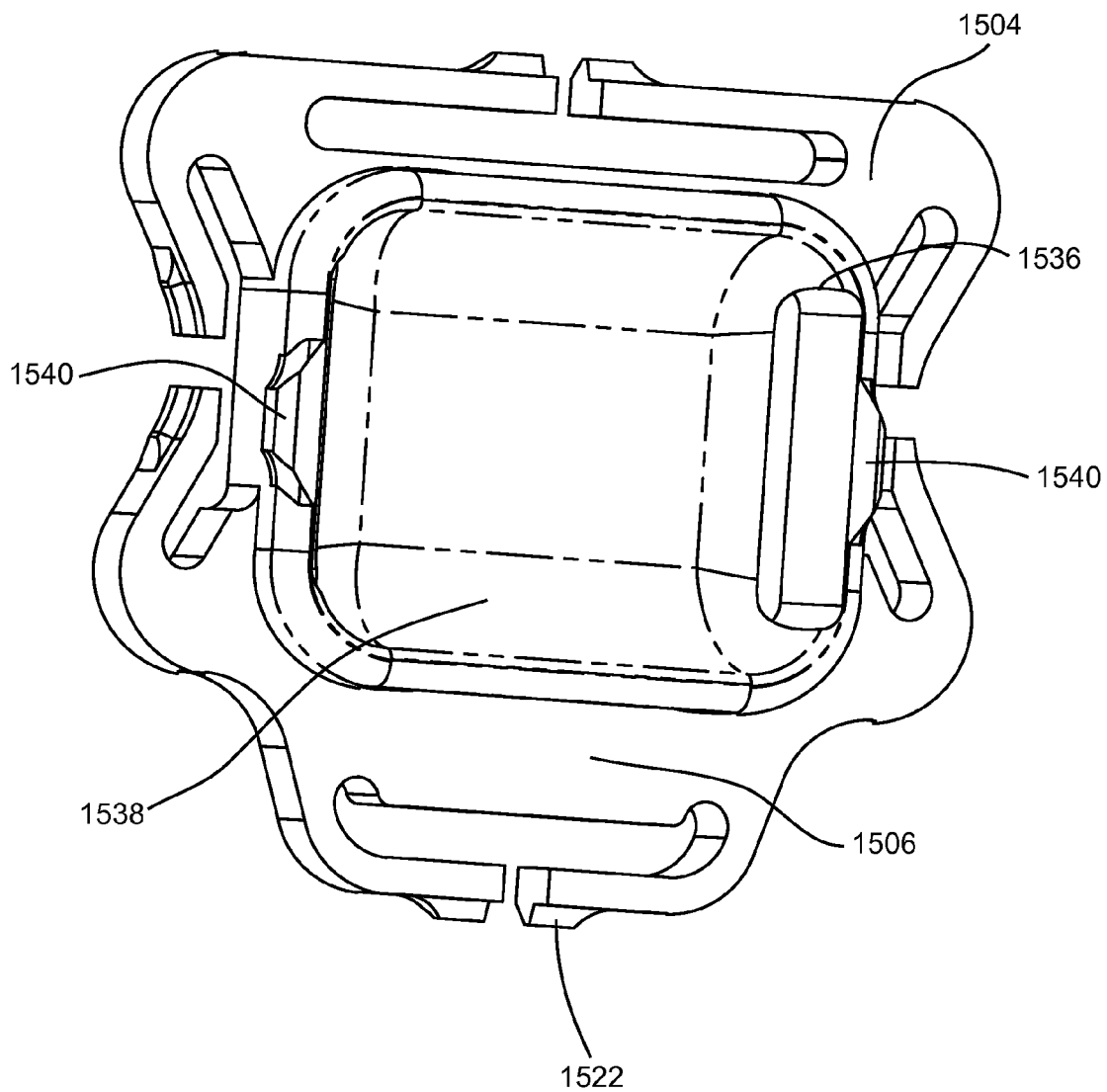

Fig. 26

UNIVERSAL SPINAL DISC IMPLANT SYSTEM

CROSS-REFERENCE TO RELATED APPLICATIONS

[0001] This application is a continuation of:
 [0002] pending prior U.S. patent application Ser. No. 11/534,985, filed Sep. 25, 2006, which carries Applicants' MLI-46 NPROV and is entitled UNIVERSAL SPINAL DISC IMPLANT SYSTEM, which claims the benefit of the following:
 [0003] U.S. Provisional Application No. 60/720,513, filed Sep. 26, 2005, which carries Applicants' Docket No. MLI-45 PROV and is entitled MODULAR ARTICULATING AND FUSION SPINAL DISC IMPLANT SYSTEM;
 [0004] U.S. Provisional Application No. 60/720,514, filed Sep. 26, 2005, which carries Applicants' Docket No. MLI-46 PROV and is entitled UNIVERSAL SPINAL DISC IMPLANT SYSTEM FOR PROVIDING INTERVERTEBRAL ARTICULATION AND FUSION; and
 [0005] U.S. Provisional Application No. 60/741,513, filed Nov. 30, 2005, which carries Applicants' Docket No. MLI-50 PROV and is entitled SYSTEM AND METHOD FOR INTERVERTEBRAL IMPLANT DELIVERY AND REMOVAL.
 [0006] All of the foregoing are incorporated herein by reference.

BACKGROUND OF THE INVENTION

[0007] 1. The Field of the Invention
 [0008] The present invention relates generally to spinal orthopedics, and more precisely, to intervertebral implants.
 [0009] 2. The Relevant Technology
 [0010] Severe back pain can be caused by a number of different ailments, including spinal stenosis, degenerative disc disease, spondylolisthesis, and the like. Many such ailments can be corrected by controlling or limiting relative motion between the affected vertebrae. Accordingly, a variety of devices including artificial discs and fusion devices have been proposed.
 [0011] Such devices are limited in that they typically provide only one mode of correction. Many such devices cannot be replaced or corrected. This is particularly true with intervertebral implants, in which bone-growth is often stimulated to integrate the implants with the surrounding bone tissue. Thus, if the device fails to solve the problem, there may be no other recourse for the patient.
 [0012] Further, many known devices are expensive or difficult to manufacture, or are difficult to implant. Some known intervertebral devices require the adjacent vertebrae to be distracted excessively, thereby endangering the surrounding ligaments and other connective tissues. Accordingly, there is a need in the art for a device that remedies these problems. Such a device would considerably enhance outcomes for patients with spinal disorders.

BRIEF DESCRIPTION OF THE DRAWINGS

[0013] Various embodiments of the present invention will now be discussed with reference to the appended drawings. It is appreciated that these drawings depict only typical embodiments of the invention and are therefore not to be considered limiting of its scope.

[0014] FIG. 1 is a perspective view of the total disc implant in a portion of the spine, according to one embodiment of the invention.
 [0015] FIG. 2 is a perspective view of the total disc implant shown in FIG. 1 in a disassembled state.
 [0016] FIG. 3 is a perspective view of the bone-facing side of the inferior end plate shown in FIG. 2.
 [0017] FIG. 4 is a perspective lateral side view of the inferior end plate shown in FIG. 2.
 [0018] FIG. 5 is a cephalad view of the bearing-facing side of the inferior end plate shown in FIG. 2.
 [0019] FIG. 6 is a perspective view of the superior end plate shown in FIG. 2.
 [0020] FIG. 7 is a perspective view of the caudal side of the inferior bearing shown in FIG. 2.
 [0021] FIG. 8 is a perspective view of the cephalad side of the inferior bearing shown in FIG. 2.
 [0022] FIG. 9 is a perspective view of the cephalad side of the superior bearing shown in FIG. 2.
 [0023] FIG. 10 is a perspective view of the caudal side of the superior bearing shown in FIG. 2.
 [0024] FIG. 11 is a perspective view of the bearing-facing side of the snap shown in FIG. 2.
 [0025] FIG. 12 is a perspective view of the end plate-facing side of the snap shown in FIG. 2.
 [0026] FIG. 13 is a lateral view of the snap shown in FIG. 2.
 [0027] FIG. 14 is a perspective view of an alternative embodiment of a total disc implant, in a disassembled state.
 [0028] FIG. 15 is a perspective view of an interbody disc fusion implant, in a disassembled state.
 [0029] FIG. 16 is a perspective view of the fusion cage shown in FIG. 15.
 [0030] FIG. 17 is a perspective view of another alternative embodiment of a total disc implant, in a disassembled state.
 [0031] FIG. 18 is a perspective view of a bone-facing side of the inferior endplate shown in FIG. 17.
 [0032] FIG. 19 is a perspective view of a bearing-facing side of the inferior endplate shown in FIG. 17.
 [0033] FIG. 20 is a perspective view of a caudal side of the inferior bearing shown in FIG. 17.
 [0034] FIG. 21 is a perspective view of a cephalad side of the inferior bearing shown in FIG. 17.
 [0035] FIG. 22 is a perspective view of a cephalad side of the superior bearing shown in FIG. 17.
 [0036] FIG. 23 is a perspective view of a caudal side of the superior bearing shown in FIG. 17.
 [0037] FIG. 24 is a perspective view of a bone-facing side of the snap fastener shown in FIG. 17.
 [0038] FIG. 25 is an enlarged perspective side view of the snap fastener shown in FIG. 17.
 [0039] FIG. 26 is a perspective view of a bearing-facing side of the snap fastener shown in FIG. 17.

DETAILED DESCRIPTION OF THE PREFERRED EMBODIMENTS

[0040] The present invention relates to human spinal disc replacement systems. Those of skill in the art will recognize that the systems and methods described herein may be readily adapted for other modular implant systems for anatomic replication of orthopedic joints by man made implant systems.
 [0041] Referring to FIG. 1, a perspective view illustrates one embodiment of an implant 50, which may be referred to as a total disc implant, implanted in a portion of the spine. In this embodiment of the invention, the total disc implant

includes two end plates **100**, **200**, two bearings **300**, **400**, and two snap fasteners **500** (not visible in FIG. 1) which releasably hold the bearings to the end plates. The implant **50** is designed for placement between spinal vertebrae to replace degenerated intervertebral disk material. More specifically, the implant **50** of FIG. 1 is designed to be inserted between the vertebral bodies **22**, **42** of the first and second vertebrae **20**, **40**, respectively, after removal of the intervertebral disc (not shown). The vertebral bodies **22**, **42** are rasped and flat surfaces on them are prepared to fit the end plates **100**, **200**.

[0042] The procedure to implant the total disc implant may be conducted from any of three approaches: anterior, right lateral, or left lateral. In addition, should there be any subsequent procedure for adjustment of the implant **50** or replacement of any component thereof, such procedure may be carried out from any one of the three approaches.

[0043] FIG. 2 illustrates the implant **50** in a disassembled state, so that all components are visible. During the implantation procedure, the end plates **100**, **200** are pressed into place onto the vertebral bodies, with the inferior end plate **100** in a caudal position on vertebral body **22**, and superior end plate **200** in a cephalic position on vertebral body **42**. The end plates **100**, **200** may be implanted in either order (inferior first or superior first). Once implanted, the two end plates **100**, **200** appear as mirror images of one another with their bearing facing sides facing one another. Next, the inferior **300** and superior bearings **400** are attached to the end plates, using the snap fasteners **500** as releasable connectors. A set force delivered by the implantation instrumentation (not shown) presses each snap fastener **500** into place. The inferior bearing **300** is attached to the inferior end plate **100** with one snap fastener **500** between them, and the superior bearing **400** is attached to the superior end plate **200** with another snap fastener **500** between them. Like the end plates, the bearings **300**, **400** may also be attached in either order.

[0044] FIG. 3 illustrates a bone-facing side of one end plate. In the illustration, the end plate depicted is the inferior end plate **100**, and so the bone-facing side **102** is in the caudal direction. In this embodiment of the invention the superior end plate **200** is identical to the inferior end plate **100** in every way except in orientation once implanted in the body. Thus, when the superior end plate **200** is implanted, its bone-facing side will be in the cephalic direction. With this exception due to orientation noted, FIGS. 3 and 4 and the description of the end plate below also apply to the superior end plate **200**. However, it is appreciated that in alternative embodiments of the invention, the end plates may or may not be identical in size, shape, or configuration.

[0045] As viewed in FIGS. 3 and 4, the inferior end plate **100** is quadrilateral in form, with rounded corners, and is bilaterally symmetrical. It has a bone-facing side **102**, a bearing-facing side **104**, an anterior end **106**, a posterior end **108**, a right end **110** and a left end **112**. The end plate is slightly wedge-shaped, with the height of the anterior end **106** slightly greater than the posterior end **108**. This is to match the natural lordotic angle of the lumbar vertebrae as closely as possible. In alternative embodiments, it is appreciated that the end plates **100**, **200** need not have a quadrilateral configuration but can be square, circular, or have any other polygonal or irregular configuration. Furthermore, it is appreciated that the end plates **100**, **200** can be configured at any desired wedge angle or can have substantially parallel top and bottom surfaces.

[0046] The inferior end plate **100** has a bone engaging face **114** and a bearing engaging face **116** which are connected by a support member **118**. Projecting from the bone engaging face **114** is a plurality of anchoring members in the form of bone engaging spikes **120**. Each bone engaging spike **120** is columnar in form and projects perpendicularly in the caudal direction from the bone engaging face **114**. The caudal end of each bone engaging spike **120** tapers and terminates in an acute angle. This angled tapering creates a point which facilitates seating the inferior end plate **100** in the adjacent vertebral body **22** during the implantation process; the point will more easily penetrate the vertebral body **22** than would a blunt end.

[0047] A hollow grafting channel **122** runs through the center of each bone engaging spike **120**. Each grafting channel **122** originates on the bearing engaging face **114**, runs through the support member **118**, and ends at the pointed termination of the bone engaging spike **120**. This hollowed point configuration may be compared to the point of a hypodermic needle, and further facilitates the penetration of the vertebral body **22** by the bone engaging spikes **120**. The grafting channels **122** also allow for the growth of bony columns from the vertebral body **22** through the channels, thereby fusing the inferior end plate **100** to the vertebral body **22**.

[0048] FIG. 5 illustrates the bearing-facing side **104** of the inferior end plate **100**. Near the corner formed by the posterior end **108** and the left end **112** is a peg port **124**. The peg port **124** is a circular opening originating on the bearing-engaging face **116** and recessed into the support member **118**. Partway through the support member **118**, the width of the peg port **124** constricts and the port continues as a grafting channel **122**, exiting through a bone engaging spike **120** on the bone-facing side **102**. A similar peg port **124** is located near the right posterior corner.

[0049] Centered on the anterior end **106** of the bearing-facing side **104** is a pocket **126**. Similar pockets are centered on the right end **110** and the left end **112**. Each pocket **126** is a rectangular segment cut from the edge of the bearing-engaging face **116** and extending caudally into the support member **118**. Once the cutaway area is below the bearing-engaging face **116**, the slot widens on either lateral side, and deepens perpendicularly into the support member **118**, toward the center of the end plate. The pockets **126** are places where implantation instruments (not shown) may grip or otherwise connect with the end plates during the implantation procedure. The number, size, configuration and placement of pockets may vary in other embodiments of the invention.

[0050] As seen in FIGS. 3, 4 and 5, a snap port **130** is located on the end plate **100**, laterally centered but slightly displaced toward posterior end **108**. The snap port **130** is an opening from the bearing-facing side **104** to the bone-facing side **102**, circumscribed by a tapered wall **132**. The tapered wall **132** angles outward toward the bone-facing side **102**, such that the cross-sectional area of the snap port **130** on the bearing-facing side **104** is smaller than the cross-sectional area of the same snap port **130** on the bone-facing side **102**.

[0051] FIG. 6 is a perspective view of the superior end plate **200**. Note that as discussed earlier, the superior end plate **200** is identical to the inferior end plate **100** in every way except in orientation once implanted. However, as illustrated, this does mean that the right end **210** and left end **212** of the superior end plate **200** are reversed from the right end **110** and left end **112** of the inferior end plate **100**.

[0052] Once the end plates 100, 200 are implanted, the bearings 300, 400 are inserted and attached to the end plates. FIG. 7 illustrates the caudal side of the inferior bearing 300. The inferior bearing 300 is of the same approximate quadrilateral shape and dimension as the inferior end plate 100. It has a caudal side 302, a cephalad side 304, an anterior end 306, a posterior end 308, a right end 310 and a left end 312. On the caudal side 302 is an end plate-engaging face 314. Centered along the anterior end 306 is an instrument port 316, which is an opening originating on the end plate engaging face 314, passing through a support member 318, and terminating on an inferior articulation surface 330. Additional instrument ports 316 are centered on the right end 310 and the left end 312. Protruding from the end plate-engaging face 314 near the posterior right and left corners are two pegs 320. The pegs 320 fit into the peg ports 124 shown in FIG. 5, when the inferior bearing 300 is attached to the inferior end plate 100. The fitting of the pegs 320 into the peg ports 124 assist in reducing shear stress on the implant.

[0053] Occupying the central area of the inferior bearing 300 is a cap 322, surrounded by a trough 324. The cap is a quadrilateral protrusion from the end plate engaging face 314, and the surface of the cap 322, while parallel to the end plate engaging face 314, is slightly elevated from it. The trough 324 which surrounds the cap is recessed from the end plate engaging face 314 into the support member 318. The outer boundary of the trough is a tapered wall 326. The tapered wall 326 angles inward from the bottom of the trough 324 to the top, such that the cross sectional area of the trough 324 at its deepest point is larger than its cross sectional area where it meets the surface of the end plate engaging face 314.

[0054] FIG. 8 displays the cephalad side 304 of the inferior bearing 300. The cephalad side has an inferior articulation surface 330 from which arises a rounded dome 332. The dome 332 is centered laterally on the cephalad side 304 of the inferior bearing 300, but is slightly displaced toward the posterior end 308.

[0055] FIG. 9 illustrates the cephalad side 402 of the superior bearing 400. It has a cephalad side 402, a caudal side 404, an anterior end 406, a posterior end 408, a right end 410 and a left end 412. On the cephalad side 404 is an end plate-engaging face 414. Centered along the anterior end 406 is an instrument port 416, which is an opening originating on the end plate engaging face 414, passing through a support member 418, and terminating on a superior articulation surface 430. Additional instrument ports 416 are centered on the right end 410 and the left end 412. Protruding from the end plate-engaging face 414 near the posterior right and left corners are two pegs 420. The pegs 420 fit into the peg ports 224 shown in FIG. 6, when the inferior bearing 400 is attached to the superior end plate 200. The fitting of the pegs 420 into the peg ports 224 assist in reducing shear stress on the implant.

[0056] Occupying the central area of the superior bearing 400 is a cap 422, surrounded by a trough 424. The cap 422 is a flat-topped protrusion from the end plate engaging face 414, and the surface of the cap 422, while parallel to the end plate engaging face 414, is slightly elevated from it. The trough 424 which surrounds the cap is recessed from the end plate engaging face 414 into the support member 418. The outer boundary of the trough is a tapered wall 426. The tapered wall 426 angles inward from the bottom of the trough 424 to the top, such that the cross sectional area of the trough 424 at its deepest point is larger than its cross sectional area where it meets the surface of the end plate engaging face 414.

[0057] The caudal side 404 of the superior bearing 400 is illustrated in FIG. 10. A rounded cup 432 is recessed into the support member 418 of the caudal side 404. The cup 432 is centered laterally on the caudal side 404, but is slightly displaced toward the posterior end 408. A ridge 434 encircles the cup 432. The ridge is raised substantially from the support member 418. A smooth superior articulation surface 430 overlays the ridge 434 and the cup 432 such that where they meet, there is no discernable transition between the two features.

[0058] As seen in FIG. 2, the snap 500 serves as the connector between the inferior end plate 100 and the inferior bearing 300, and between the superior end plate 200 and the superior bearing 400. FIGS. 11, 12 and 13 illustrate the snap 500 alone. In this embodiment of the invention, the snap 500 is quadrilateral and generally dish-like in form, with a bone-facing side 502 which is a substantially flat plane, and a bearing facing side 504 which is a flat plane circumscribed by a raised rim 506. It is appreciated that in alternative embodiments of the invention, the snap feature may be quadrilateral, circular or any other shape or configuration. The outer edge of the rim 506 is formed by a dual-tapered wall 508. As seen best in FIG. 13, the dual-tapered wall 508 is equally wide at the bone-facing side 502 and at the bearing-facing side 504, but constricts at the midpoint between the two sides 502, 504.

[0059] FIG. 2 best illustrates how all the components of the implant 50 fit together. During or after manufacture, but before the implantation procedure, one snap 500 is fitted over the cap 322 of the inferior bearing 300, and a second snap 500 is fitted over the cap 422 of the superior bearing 400. As the rim 506 of the snap 500 is pressed into the trough 324 of the inferior bearing 300, the dual-tapered wall 508 compresses to pass into the trough 324, then expands out into place such that the dual-tapered wall 508 fits against the tapered wall 326 of the trough. Because the widest part of the dual-tapered wall 508 is wider than the opening of the trough 324, the snap 500 is locked into place, and can only be removed from the inferior bearing 300 with significant force. The second snap 500 is attached to the superior bearing 400 in the same manner.

[0060] The inferior end plate 100 is implanted in the vertebral body 22, and the superior end plate 200 is implanted in the vertebral body 42. The inferior bearing 300 is pressed into place in the inferior end plate 100. The bone-facing side 502 of the snap 500, now protruding from the caudal side 302 of the inferior bearing 300, is pressed into the snap port 130 of the inferior end plate 100. As the bone-facing side 502 of the snap 500 is pressed into the snap port 130, the dual-tapered wall 526 compresses to pass into the snap port 130, then expands out into place such that the dual-tapered wall 526 fits against the tapered wall 132 of the inferior end plate 132. Because the widest part of the dual-tapered wall 526 is wider than the opening of the snap port 130, the snap 500 is locked into place, and can only be removed from the inferior end plate 100 with significant force.

[0061] The superior bearing 400 and its snap 500 are attached to the superior end plate 200, in the same manner as described above for the inferior end plate 100 and bearing 300. Then the inferior articulation surface 330 is allowed to contact the superior articulation surface 430. Although in this description, the inferior bearing and its snap were attached first, followed by the superior bearing and its snap, it is appreciated that the bearings may be attached in either order. It is also appreciated that should there be any subsequent procedure for replacement or adjustment of any of the end

plates, bearings or snaps, such procedure may be carried out from any one of the three approaches; anterior, left lateral or right lateral.

[0062] Other embodiments of the invention can provide the same function while employing alternate snap connections. FIG. 14 depicts a disassembled total disc implant 60, which employs an alternate snap feature to lock the bearings to the end plates. In this embodiment, the inferior bearing 300 is connected to the inferior end plate 100 via a ring-shaped snap 500. Similarly, the superior bearing 400 is connected to the superior end plate 200 by the same ring-shaped snap 500. The mechanism by which the snap locks the bearings to the end plates is equivalent to the snap feature described in the first embodiment; in both embodiments the snap feature compresses to pass through a constrictive feature, and then expands out to lock the components in place.

[0063] If fusion of the vertebrae is required, an embodiment of the invention including a fusion block may be implemented. FIG. 15 depicts an interbody disc fusion implant 70, in a disassembled state. In this embodiment, the implant consists of an inferior end plate 100, a superior end plate 200, two ring-shaped snaps 500 and a fusion cage 600. The interbody disc fusion implant 70 may be implanted from an anterior approach, a right lateral approach, or a left lateral approach. It may be implanted as part of the initial implantation procedure, or it may replace inferior and superior bearings, upon their removal.

[0064] FIG. 16 illustrates the fusion cage 600. In this embodiment of the invention, the fusion cage 600 is quadrilateral and box-like in shape. It has a caudal side 602, a cephalad side 604, an anterior end 606, a posterior end 608, a right end 610 and a left end 612. It is symmetrical such that the right and left ends 610, 612 are minor images of one another and the caudal and cephalad sides 602, 604 are also minor images. A plurality of notches 630, designed for gripping by implantation instruments (not shown) are at the edges of the caudal and cephalad sides 602, 604.

[0065] A plurality of grafting holes 614 perforates each end of the fusion cage. Before, during or after positioning of the end plates between the vertebral bodies, the fusion cage 600 is at least partially packed with an osteogenic substance. In this application, "osteogenic substance" is broadly intended to include natural bone, such as autogenous bone graft or bone allograft, synthetic bone, growth factors and cytokines (including bone morphogenic proteins), and/or combinations thereof. After implantation, growth of bone material through the grafting holes will assist in the fusion of the fusion cage and end plates to the vertebrae.

[0066] A larger grafting port 616 is centered on the fusion block, with its openings on the caudal and cephalad sides. Recessed into the surface of the fusion block 600 and circumscribing the grafting port 616, is a trough 618. Around each opening of the grafting port, but to the inside of the trough 618, is a raised rim 620. The raised rim 620 protrudes from surface of the fusion block 600. The inner wall 622 of the raised rim 620 is smooth and is a continuous part of the grafting port 616. The outer wall 624 of the raised rim 620 constricts between the top of the rim and where it joins the trough 618. This constriction is designed to hold the snap ring 500, seen in FIG. 15.

[0067] Referring to FIG. 17, an alternative embodiment of a total disc implant is shown. The implant 1050 comprises an inferior end plate 1100, a superior end plate 1200, an inferior bearing 1300, a superior bearing 1400, and two snap fasteners

1500. As with the implant 50, the implant 1050 is designed for placement between spinal vertebrae to replace degenerated intervertebral disk material. Methods for placement, assembly and implantation of the implant 1050 are the same as those described for the implant 50.

[0068] Referring to FIG. 18, an enlarged view of a bone-facing side of the end plate 1100 is shown. The end plates 1100, 1200 are identical to one another, differing only in their orientation as they are placed between the vertebral bodies. End plate 1100 will be described in detail, but it is appreciated that the same description applies to the end plate 1200. The end plate 1100 has a bone-facing side 1102, and a bearing-facing side 1104. An irregularly shaped snap port 1130 occupies the center of the end plate 1100, creating an opening from the bone-facing side 1102 to the bearing-facing side 1104. A plurality of bone-engaging spikes 1120 are located on the bone-facing side 1102, each adjacent to a grafting channel 1122. Each bone-engaging spike 1120 is of a crescent shape, protruding from the bone-facing side 1102 and terminating with an acute edge. Several small diameter bone-engaging spikes 1121, with small grafting channels 1123 are interspersed with the bone-engaging spikes 1120 and grafting channels 1122.

[0069] The large size of the grafting channels 1122 creates favorable conditions for bone ingrowth once the implant 1150 is in place. Also, the crescent shapes of the bone-engaging spikes 1120 allow for good engagement with the vertebral body, but without requiring an excessive amount of force to press into place. The spikes 1122, 1121 also provide shear resistance once the end plate 1100 is implanted in the vertebral body.

[0070] The snap port 1130 occupies much of the surface area of the end plate 1100. The large opening size of the snap port 1130 maximizes space available for bone ingrowth. The irregular shape of the snap port 1130 allows more contact area for the snap connection, and offers more torsional resistance than a regularly shaped, round port. The snap port 1130 is encircled by a wall 1132. At several points on the wall 1132, a recess 1134 is indented into the wall 1134.

[0071] Referring to FIG. 19, an enlarged view of the bearing-facing side 1104 of the end plate 1100 is shown. The end plate 1100 has an anterior end 1106 and a posterior end 1108. The grafting channels 1122, 1123 open out on the bearing facing side 1104, as does the snap port 1130. Three pockets 1126 are indented into sides of the end plate 1100, on the anterior end 1106 and the two lateral sides. The pockets 1126 are shaped to engage with the instruments used to insert the end plate 1100.

[0072] Referring to FIG. 20, a caudal side of the inferior bearing 1300 is shown. The inferior bearing 1300 has a caudal side 1302, a cephalad side 1304, an anterior end 1306 and a posterior end 1308. Three instrument ports 1316 perforate the inferior bearing 1300, one on the anterior end 1306 and one on each lateral side. A rounded cap 1322 protrudes from the center of the caudal side 1302, and is surrounded by a trough 1324. The trough 1324 is surrounded by a wall 1326. Indented into each lateral side of the wall 1326 is a long recess 1328.

[0073] Referring to FIG. 21, the cephalad side 1304 of the inferior bearing 1300 is shown. The three instrument ports 1316 open out on the cephalad side 1304. A round dome 1332 rises from the surface of the cephalad side 1304.

[0074] Referring to FIG. 22, a cephalad side of the superior bearing 1400 is shown. The superior bearing 1400 has a cephalad side 1402, a caudal side 1404, an anterior end 1406,

and a posterior end **1408**. Three instrument ports **1416** perforate the inferior bearing **1400**, one on the anterior end **1406** and one on each lateral side. A rounded cap **1422** protrudes from the center of the caudal side **1402**, and is surrounded by a trough **1424**. The trough **1424** is surrounded by a wall **1426**. Indented into each lateral side of the wall **1426** is a long recess **1428**.

[0075] Referring to FIG. 23, the caudal side **1404** of the superior bearing **1400** is shown. The three instrument ports **1416** open out on the caudal side **1404**. A circular ridge **1434** rises from the caudal side **1404** of the superior bearing **1400**. In the center of the circle formed by the ridge **1434**, a cup **1432** is depressed into the superior bearing **1400**. The cup **1432** on the superior bearing **1400** and the dome **1432** on the inferior bearing **1300** form the bearing surfaces when the implant **1050** is implanted.

[0076] Referring to FIG. 24, a bone-facing side **1502** of one snap fastener **1500** is shown. The bone-facing side **1502** is flat and has a generally square shape, with a central body **1506** and an irregular outer edge **1508**. The snap fastener has an anterior end **1510**, a posterior end **1512**, and two lateral sides **1514**. Two connection slots **1516** perforate the snap fastener, each generally parallel to a lateral side **1512** of the body **1506**. Four connection ports **1518** are located just inside the outer edge **1508**, one each on the anterior and posterior ends **1510**, **1512**, and one on each lateral side **1514**. There is a gap **1520** in the outer edge **1508** adjacent to each connection port **1518**, such that the outer edge **1508** is not continuous but each connection port **1518** has an opening to the outside of the fastener **1500**. Formed onto the outer edge **1508** immediately adjacent to each gap **1520** is a tab **1522**, each tab **1522** being a protrusion from the outer edge **1508**, extending in the same plane as the body **1506**.

[0077] Referring to FIG. 25, an enlarged side view of a snap fastener **1500** is shown, in order to depict the tabs **1522** in greater detail. Each tab **1522** has a sloped bone-facing side **1532** and a sloped bearing-facing side **1534**. The slope of the bearing-facing side **1534** is steeper than the slope of the bone-facing side **1532**. This is so that when the tabs **1522** are snapped into the recesses **1134** in the walls **1132** of the end plate **1100**, more force is required to remove the snap fastener **1500** from the end plate **1100** than it takes to snap the snap fastener **1500** to the end plate **1100** or **1200**.

[0078] Referring to FIG. 26, a bearing-facing side **1504** of the snap fastener **1500** is shown. In the center of the body **1506**, a raised rim **1536** surrounds a rectangular dish **1538**. Protruding on each lateral side of the rim **1536** is a long tab **1540**. The long tabs **1540** are configured to fit into the long recesses **1328**, **1428** on the bearings **1300**, **1400** when the snap fastener **1500** is snapped to the bearing. Returning to FIG. 25, each long tab **1540** has a bone-facing side **1542** and a bearing-facing side **1544**. The slope of the bone-facing side **1542** is 90 degrees, and the slope of the bearing-facing side **1544** is less steep, approximating 45 degrees. This is so that when the snap fastener **1500** is snapped on to the inferior or superior bearing **1300**, **1400**, it will require considerably less force to snap the fastener **1500** on the bearing than to remove it.

[0079] When the snap fastener **1500** is snapped on to the end plate **1100**, the bone-facing side **1532** of the tab **1522** pushes against the bearing-facing side **1104** of the end plate **1100**, and the outer edge **1508** flexes slightly until the tab **1522** is forced into the recess **1134**. Since the slope on the

bearing-facing side **1534** of the tab **1522** is steeper, it would take much more force to remove the tab **1522** from the recess **1134**.

[0080] The present invention may be embodied in other specific forms without departing from its spirit or essential characteristics. It is appreciated that various features of the above-described examples can be mixed and matched to form a variety of other alternatives, each of which may have a different bearing set, fusion block, or snap connection system according to the invention. As such, the described embodiments are to be considered in all respects only as illustrative and not restrictive. The scope of the invention is, therefore, indicated by the appended claims rather than by the foregoing description. All changes which come within the meaning and range of equivalency of the claims are to be embraced within their scope.

1. An intervertebral implant comprising:

- a first end plate configured to be secured to a first vertebral body adjacent to an intervertebral space; and
- a first intermediate component configured to be lockable into a locked position relative to the first end plate in response to motion between the first intermediate component and the first end plate, wherein the first intermediate component comprises a concave articular surface.

2. The intervertebral implant of claim 1, wherein the first intermediate component is positionable in a free position relative to the first end plate, wherein in the free position, relative motion between the first intermediate component and the first end plate is unrestricted, wherein the first intermediate component is movable between the locked and free positions along a straight pathway having a length of 6 millimeters or less.

3. The intervertebral implant of claim 2, wherein a first force required to lock the first intermediate component into the locked position relative to the first end plate is less than a second force required to move the first intermediate component from the locked position to the free position relative to the first end plate.

4. The intervertebral implant of claim 1, wherein a force required to lock the first intermediate component into the locked position relative to the first end plate is 20 pounds or less.

5. The intervertebral implant of claim 1, wherein the first intermediate component is further configured to be locked in response to motion of the first intermediate component toward the first end plate along a cephalad-caudal path.

6. The intervertebral implant of claim 1, further comprising:

- a second end plate configured to be secured to a second vertebral body adjacent to the intervertebral space; and
- a second intermediate component configured to be lockable into a locked position relative to the second end plate in response to motion between the second intermediate component and the second end plate, wherein the second intermediate component comprises a convex articular surface shaped to articulate with the concave articular surface.

7. The intervertebral implant of claim 1, further comprising a snap fastener separate from the first end plate and the first intermediate component, wherein the snap fastener is shaped to be secured to the first intermediate component and to snap into engagement with the first end plate.

- 8. An intervertebral implant comprising:
a first end plate configured to be secured to a first vertebral body adjacent to an intervertebral space; and
a first intermediate component configured to be reversibly lockable into a locked position relative to the first end plate in response to motion of the first intermediate component toward the first end plate along a cephalad-caudal path.
- 9. The intervertebral implant of claim 8, wherein the first intermediate component further comprises a free position relative to the first end plate, wherein in the free position, relative motion between the first intermediate component and the first end plate is unrestricted, wherein the first intermediate component is movable between the locked and free positions along a straight pathway having a length of 6 millimeters or less.
- 10. The intervertebral implant of claim 9, wherein a first force required to lock the first intermediate component into the locked position relative to the first end plate is less than a second force required to move the first intermediate component from the locked position to the free position relative to the first end plate.
- 11. The intervertebral implant of claim 8, wherein a force required to lock the first intermediate component into the locked position relative to the first end plate is 20 pounds or less.
- 12. The intervertebral implant of claim 8, further comprising:
a second end plate configured to be secured to a second vertebral body adjacent to the intervertebral space; and
a second intermediate component configured to be lockable into a locked position relative to the second end plate in response to motion between the second intermediate component and the second end plate, wherein the second intermediate component comprises a convex articular surface shaped to articulate with the concave articular surface.
- 13. The intervertebral implant of claim 12, further comprising a third intermediate component configured to be lockable into a locked position relative to the first and second end plates in response to motion between the third intermediate component and the first and second end plates, wherein the third intermediate component comprises a fusion block configured to substantially prevent relative motion between the first and second end plates.
- 14. The intervertebral implant of claim 8, further comprising a snap fastener separate from the first end plate and the first intermediate component, wherein the snap fastener is

- shaped to be secured to the first intermediate component and to snap into engagement with the first end plate.
- 15. A method of implanting an intervertebral implant on a spine comprising a first vertebral body adjacent to an intervertebral space, the method comprising:
securing a first end plate to the first vertebral body;
moving a first intermediate component to a locked position relative to the first end plate, the first intermediate component comprising a concave articular surface; and
locking the first intermediate component in the locked position relative to the first end plate in response to the relative motion.
- 16. The method of claim 15, wherein moving the first intermediate component to the locked position comprises moving the first intermediate component from a free position along a straight pathway to the locked position, the straight pathway having a length of 6 millimeters or less, wherein, in the free position, relative motion between the first intermediate component and the first end plate is unrestricted.
- 17. The method of claim 16, wherein moving the first intermediate component to the locked position comprises exerting a first force on the first intermediate component, wherein the first force is less than a second force that would be required to move the first intermediate component from the locked position to the free position.
- 18. The method of claim 15, wherein moving the first intermediate component to the locked position comprises exerting a first force on the intermediate component, wherein the first force is 20 pounds or less.
- 19. The method of claim 15, wherein moving the first intermediate component to the locked position comprises moving the first intermediate component toward the first end plate along a cephalad-caudal path.
- 20. The method of claim 15, further comprising:
securing a second end plate to a second vertebral body adjacent to the intervertebral space; and
moving a second intermediate component to a locked position relative to the second end plate, the second intermediate component comprising a convex articular surface shaped to articulate with the concave articular surface; and
locking the second intermediate component in the locked position relative to the second end plate in response to the relative motion.

* * * * *