

(12) **UK Patent Application** (19) **GB** (11) **2 171 828 A**

(43) Application published 3 Sep 1986

<p>(21) Application No 8605041</p> <p>(22) Date of filing 28 Feb 1986</p> <p>(30) Priority data (31) 60/040621 (32) 1 Mar 1985 (33) JP 60/170143 (32) 31 Jul 1985</p>	<p>(51) INT CL⁴ G06K 9/78 A61B 5/00</p> <p>(52) Domestic classification (Edition H): G4R 11D 11E 12A 1X 5B 8A 8G 9B EP EX</p> <p>(56) Documents cited GB 1543602 GB 1304555 GB 1150511 GB 1506611 GB 1292646 EP A1 0010611 GB 1338787</p> <p>(58) Field of search G4R G4H Selected US specifications from IPC sub-class G06K</p>
<p>(71) Applicant Mitsubishi Denki Kabushiki Kaisha (Japan), 2-3 Marunouchi 2-chome, Chiyoda-ku, Tokyo, Japan</p> <p>(72) Inventors Bujiro Kobayashi Hiroshi Gamo Masatoshi Kimura</p> <p>(74) Agent and/or Address for Service Beresford & Co, 2-5 Warwick Court, High Holborn, London WC1R 5DJ</p>	

(54) **An individual recognition system**

(57) An individual recognition system includes a card 20 storing a fingerprint of the right card possessor, and a card reader 30 which judges whether a card possessor is the right card possessor or not based upon the result of comparison of the fingerprint of the card possessor with the fingerprint registered in the card 20. The judging means may, alternatively, be provided in the card.

F I G . 1.

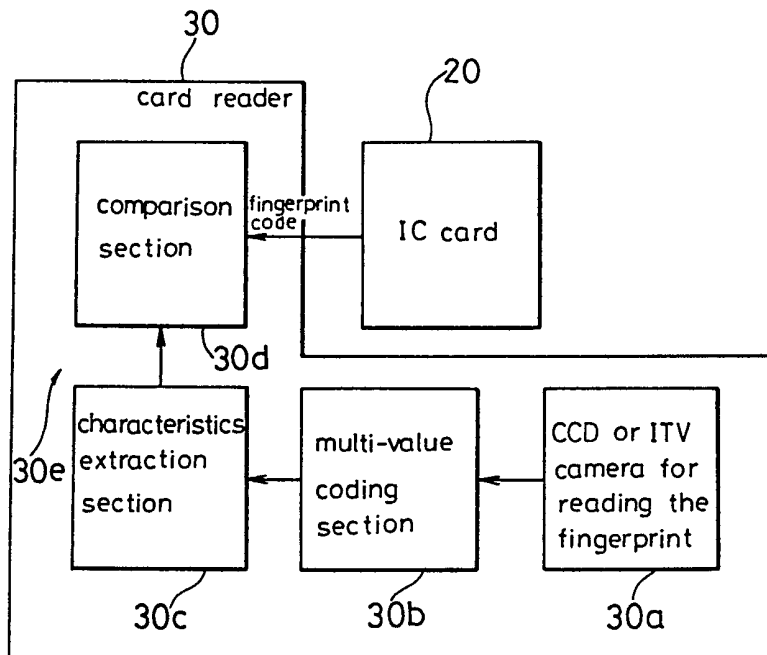

GB 2 171 828 A

F I G . 1.

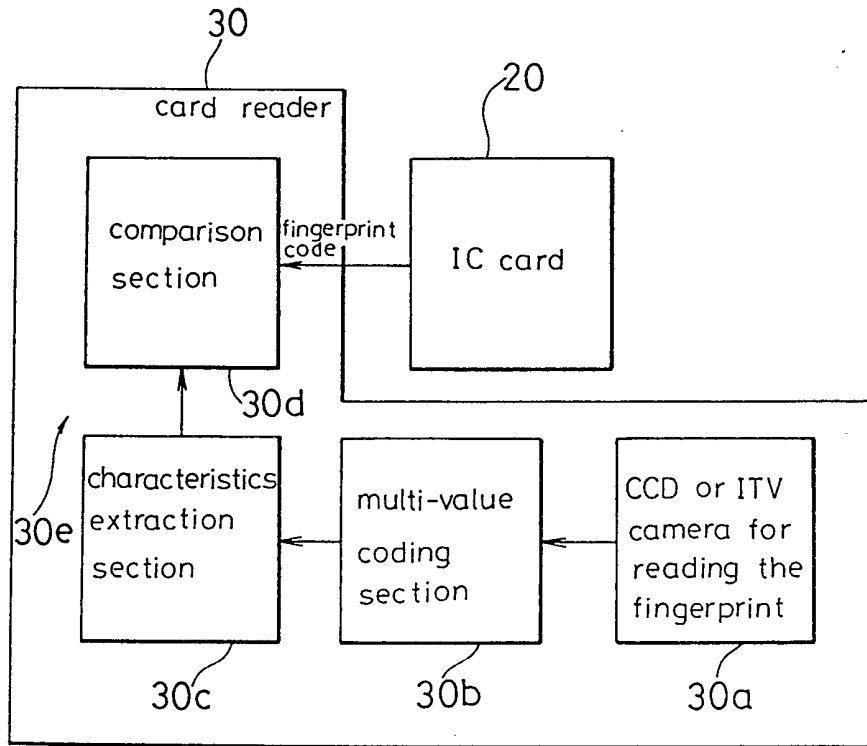

F I G . 2.

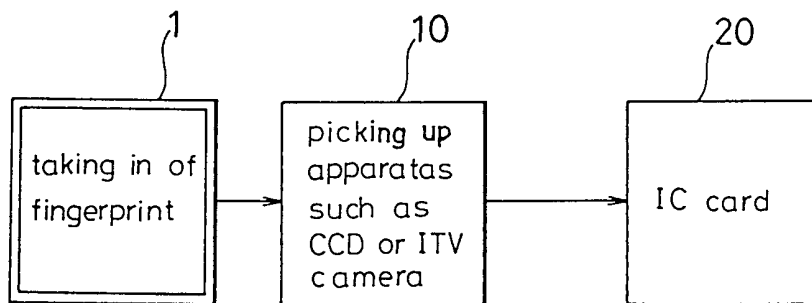

FIG. 3.

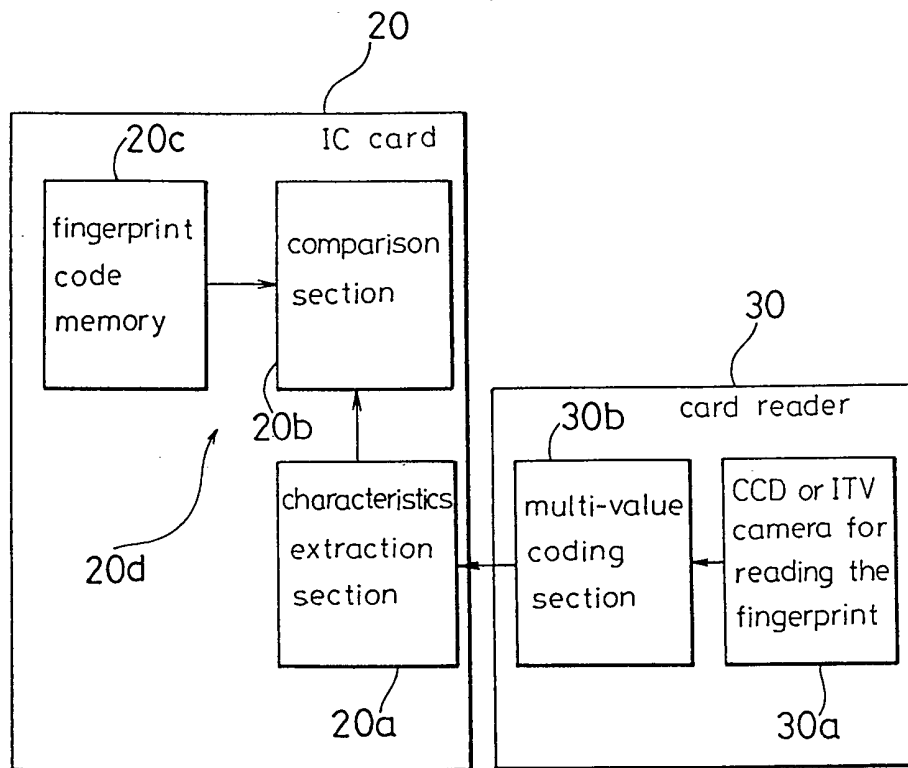

FIG. 4.

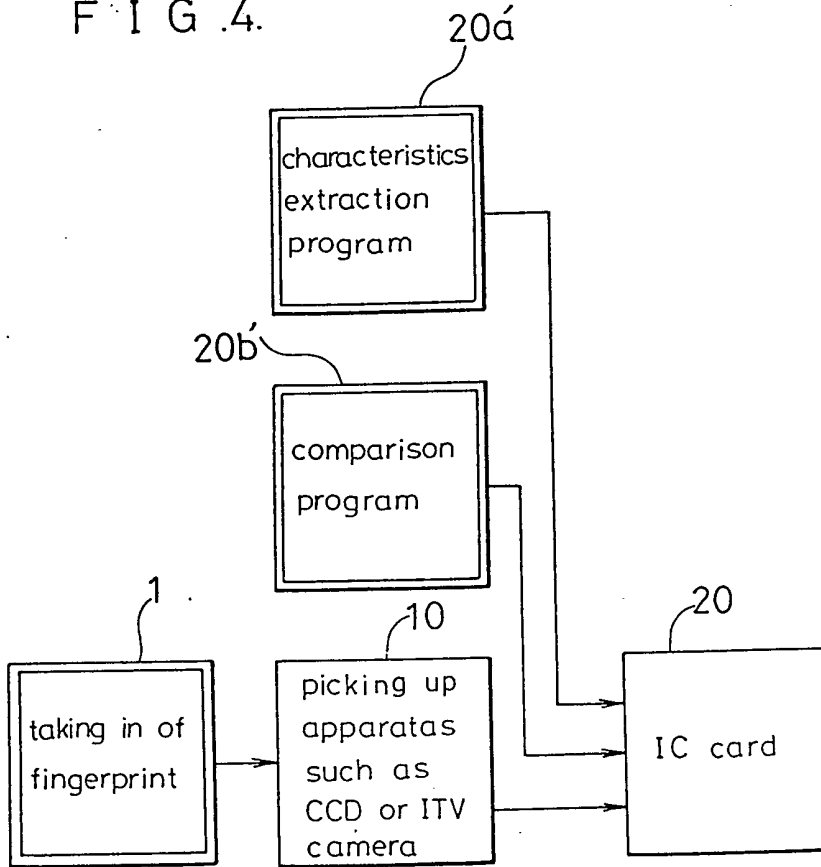

FIG. 5.

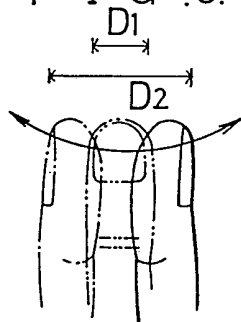
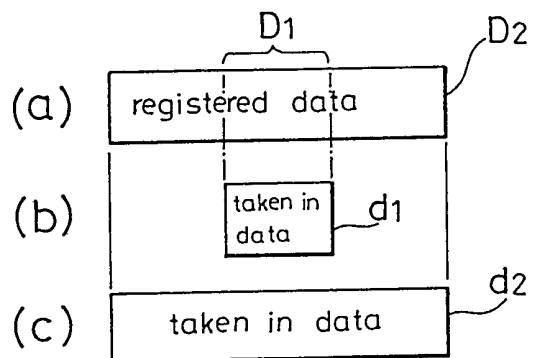

FIG. 6.



SPECIFICATION

An individual recognition system

5 FIELD OF THE INVENTION

The present invention relates to a system for recognizing an individual with the use of a higher level recognition method.

10 BACKGROUND OF THE INVENTION

Recently, a card having a magnetic stripe is widely used in a system for recognizing a particular individual (The recognition card is abbreviated as M/S card). For example, in a card to be used for a deposit drawing apparatus installed in a bank (hereinafter referred to as "deposit card") there are stored a code for recognizing the genuineness of the card and a recitation code for judging as to whether a card possessor is a right card possessor registered in the card or not. Accordingly, the deposit drawing apparatus is designed to read out the genuineness code in the card thereby to judge as to whether the card is genuine or not, to instruct the card possessor to input a recitation code from the key board, and to judge as to whether the card possessor is a right card possessor or not based upon the result of comparison of the input recitation code with the recitation code registered in the card. In this system, a numeral or symbol sequence which is relatively easy to memorize is appropriate for use as a recitation code.

The above described method is widely used because the truth or falsehood of the card possessor is relatively easily judged.

However, this system has a few disadvantages described in the following:

The first one arises caused by that the recitation code must be memorized by a card possessor by himself. That is, the safety against a crime is inevitably lowered because a card possessor is likely to use a simple recitation code so as not to occur a misunderstanding or a lapse of the recitation code. However, when a too complicated code exceeding the memory of a human being such as a certificate of one's seal impression is used instead of the recitation code, it is very troublesome or difficult to bring the recitation code with himself, and furthermore there arises an anxiety of burglary. This means that it results in no improvement in the safety.

55 SUMMARY OF THE INVENTION

The present invention is directed to solve the problems pointed out above, and has for its object to provide an individual recognition system capable of unnecessitating the memorization of the recitation code and of enhancing the safety with no anxiety of forgery.

Other objects and advantages of the present invention will become apparent from the detailed description given hereinafter; it should be understood, however, that the detailed de-

scription and specific embodiment are given by way of illustration only, since various changes and modifications within the spirit and scope of the invention will become apparent to those skilled in the art from this detailed description.

70 According to the present invention, there is provided an individual recognition system for judging as to whether a card possessor is a right card possessor or not, comprising: a card storing a fingerprint of the right card possessor; a card reader to which the card is inserted, and which is intended to read the fingerprint of the card possessor; and a judging means for judging as to whether a card possessor is a right card possessor or not based upon the result of comparison of the fingerprint of the card possessor taken in by the card reader with the fingerprint registered in the card, which judging means is provided in the card or the card reader.

BRIEF DESCRIPTION OF THE DRAWINGS

Figure 1 is a block diagram showing a construction of an individual recognition system according to an embodiment of the present invention:

Figure 2 is a diagram for exemplifying the method for taking in a fingerprint in the apparatus of Figure 1;

Figure 3 is a diagram showing a construction of an individual recognition system as a second embodiment of the present invention;

Figure 4 is a diagram for exemplifying what information is stored as a registered fingerprint in the second embodiment;

Figure 5 is a diagram for exemplifying the method of taking out a fingerprint in the second embodiment; and

Figure 6 is a diagram for exemplifying the comparison operation of the second embodiment.

110 DETAILED DESCRIPTION OF THE PREFERRED EMBODIMENTS

The present invention provides an individual recognition system in which a fingerprint is used instead of a recitation code. It is easily understood that a fingerprint is most appropriate to be used as a recitation code because it is inherent to an individual.

In order to explain the present invention in detail, reference will be particularly made to Figure 1: In the following example an IC card is used as a card storing the fingerprint. An IC card includes semiconductor elements such as a memory IC or a CPU in a card, and has a larger memory capacity by several columns than the M/S card. Furthermore, it involves desired operational functions such as characteristics extraction and comparison.

Figure 1 is a block diagram showing an individual recognition system as an embodiment of the present invention. In Figure 1, the reference numeral 20 designates an IC card storing

the fingerprint of the card possessor as an individual information. That is, the characteristics of the depth and interval of the fingerprint are registered in the card 20. The reference numeral 30 designates a card reader intended to read out an information stored in the IC card 20 which is inserted thereinto. In the card reader 30, the reference numeral 30a designates a CCD camera or an ITV camera for reading the fingerprint. The numeral 30b designates a multi-value coding section intended to execute a multi-value coding to the information read by the camera 30a. The numeral 30c designates a characteristics extraction section intended to extract the characteristics such as the depth and the interval of the fingerprint stored in the IC card 20 from the output of the multi-value coding section 30b. The numeral 30d designates a comparison section intended to compare the output of the characteristics extraction section 30c and the information read out from the IC card 20. As apparent from the above the characteristics extraction section 30c and the comparison section 30d constitute a judging means 30e for judging the truth or falsehood of the card possessor, that is, whether the possessor of the card 20 is a right possessor or not.

As apparent from the above, the card reader 30 has the following functions for judging the truth or falsehood of the card possessor:

- (1) An interface function to read a fingerprint code stored in the IC card (not shown).
- (2) A function to read a fingerprint of a particular finger of a card possessor (this is accomplished by the CCD camera or ITV camera 30a and the multi-value coding section 30b).
- (3) A function to compare the two fingerprints to judge whether they are the same or not (this is accomplished by the characteristics extraction section 30c and the comparison section 30d).

Such functions are easily realized by using known methods.

The operation of the registration of the fingerprint information into the IC card 20 is described in the following:

The fingerprint of a particular finger is picked up by a camera as a picture, and the picture information of the fingerprint 1 is converted into an electric signal by a light-electricity conversion. Or a fingerprint may be directly picked up by a CCD camera or an ITV camera 10. A characteristics extraction is executed to this fingerprint by a known data compressing method, and it is multi-value coded with the use of a gradation code of 6 to 8 bits for multi-value coding. Thus, the fingerprint pattern is converted into an electric signal, and the pattern code is stored in the IC card 20. Although it is required a memory capacity of about 64 K bite for storing a raw fingerprint pattern, the required memory capacity

can be reduced to about 1 K bite when only the characteristics such as the depth and interval of the fingerprint are stored. Then, the code number of the card or the like can be stored by using the remaining memory capacity. The double rectangle in Figure 2 is used to indicate that the content of the block is registered in the IC card 20. The same also applies to Figure 4.

The device is operated as follows:

When a card possessor inserts the IC card 20 into the card reader 30, and places a particular finger on a window for taxing in a fingerprint, the fingerprint of the card possessor (which is an information for-comparison) is picked up. The picked up signal is coded into a gradation code signal by the multi-value coding section 30b, and a characteristics extraction is executed to this signal by the characteristics extraction section 30c to be output to the comparison section 30d. In the comparison section 30d the fingerprint code read out from the IC card 20 and the extracted characteristics information are compared with each other, and it is judged as to whether the possessor of the card is a right card possessor or not.

In this embodiment under such a construction, a fingerprint is used as a recitation code, whereby the necessity of memorizing a recitation code comprising such as a numeral sequence is removed, resulting in easeness and conveniency at a practical use. Furthermore, a forgery of the card is unabled, resulting in a high safety.

Figure 3 shows another embodiment of the present invention wherein the characteristics extraction function and the comparison function are involved in the IC card 20. In Figure 3 the same numerals designate the same elements as those shown in Figure 1. The reference numeral 20d designates a judging means comprising a characteristic extraction section 20a and a comparison section 20b, and this judging means 20d is provided in the IC card 20. The card reader 30 comprises only a CCD camera or ITV camera 30a and a multi-value coding section 30b. Herein, the numeral 20c designates a memory storing the fingerprint code.

In this embodiment, not only the fingerprint 1 but also a characteristics extraction program 20a' and a comparison program 20b' are registered in the IC card 20 as shown in Figure 4, and the respective functions of the characteristics extraction section 20a and the comparison section 20b in the IC card 20 are realized by the respective programs 20a' and 20b'. The both programs 20a' and 20b' are stored with the use of the memory capacity other than that for the fingerprint code.

The operation of this embodiment is almost the same as that of the first embodiment. In addition thereto, there is no necessity of providing the characteristics extraction function

and the comparison function at the card reader 30, thereby making the card reader 30 miniaturized and low cost thereby to realize a portable fingerprint comparison system.

5 In the illustrated embodiment a fingerprint in planer configuration is used as a fingerprint to be registered, but a fingerprint in stereoscopic configuration can be used.

A fingerprint in stereoscopic configuration to be registered is obtained by extending a real stereoscopic configuration of the fingerprint into a planer configuration by rotating the finger. A fingerprint in stereoscopic configuration is registered into the IC card 20 in such a manner that the fingerprint obtained by the rotating method is directly picked up by a CCD or ITV camera, and a characteristics extraction is executed thereto by a known data compressing method with the use of a gradation code of 6 to 8 bits for multi-value coding. Thus, the characteristics of the fingerprint is converted into an electric signal, and this fingerprint code is stored in the memory (ROM) in the IC card 20. It is generally required a memory capacity of about 64 K bits for a raw fingerprint, but it can be reduced up to about 1 K bits when only the characteristics such as the depth and interval of the fingerprint are stored. Then, the code number of the card or the like can be stored with the use of the remaining memory capacity. The information of rotation speed of the finger at the taking in of the fingerprint is also registered with the fingerprint information in the IC card 20.

This stereoscopic configuration fingerprint registered in the IC card 20 is used as a whole or a part thereof when it is difficult to judge the truth or falsehood of the card possessor only on the basis of the result of comparison of the data D1 in planer configuration and the data d1 in planer configuration as the output of the characteristics extraction section 30c. In greater detail, when it is suspicious about the truthhood of the card possessor as described above a fingerprint in stereoscopic configuration of the card possessor is taken in together with the rotation speed information with the use of the above described rotation method, and the extracted characteristics coded into two-values is subjected to a characteristics extraction. And then, this data d2 (refer to Figure 3(c)) is compared with the registered data D2 in the IC card 20.

10 In this embodiment utilizing a stereoscopic configuration fingerprint it is more likely possible to prevent a forgerious input of a fingerprint than the first embodiment utilizing a planer configuration fingerprint. This enhances the safety against crimes to a great extent. Furthermore, the rotation speed information of the finger at the taking in of the fingerprint can be used in the comparison when there is a suspicion, thereby enabling to obtain a right judgement even when a stereoscopic configura-

tion fingerprint of a right card possessor is input under an intimidation by other person. As a result, it is enhanced the preciseness in the judgement about the truthhood of the card possessor.

70 In the above illustrated embodiments IC cards are used as a card, but a laser card capable of random access of reading and writing by a laser can be used.

75 As described above, according to the present invention, a fingerprint in planer or stereoscopic configuration is used instead of a recitation code, thereby resolving the disadvantages of the recitation method. Furthermore, a forgery of a card and a forgerious input of the fingerprint are unable, thereby realizing a quite safety system.

CLAIMS

- 85 1. An individual recognition system for judging as to whether a card possessor is an authorised person or not, comprising:
 a card storing a fingerprint of an authorised person;
 90 a card reader to which the card is inserted, and which is intended to read the fingerprint of the card possessor; and
 a judging means for judging as to whether a card possessor is an authorised person or not based upon the result of comparison of the fingerprint of the card possessor taken in by the card reader with the fingerprint registered in the card, which judging means is provided in the card or the card reader.
- 100 2. An individual recognition system for judging as to whether a card possessor is an authorised person or not, comprising:
 a card storing the whole or a portion of a stereoscopic fingerprint of an authorised person;
 105 a card reader to which the card is inserted, and which is intended to read the whole or a portion of a stereoscopic fingerprint of the card possessor; and
 a judging means for judging as to whether a card possessor is an authorised person or not based upon the result of comparison of the whole or a portion of the stereoscopic fingerprint of the card possessor taken in by the card reader with the whole or a portion of the stereoscopic fingerprint registered in the card, which judging means is provided in the card or the card reader.
- 115 3. A card for use in financial transactions having permanently stored therein a fingerprint or data representing a fingerprint in machine readable form.
- 120 4. Card reading apparatus for use with a card according to claim 3, having means for receiving the card and for reading said stored fingerprint or fingerprint representing data, means for reading the print of an actual finger presented to the apparatus, and means for comparing the print of the actual finger with the fingerprint or data read from the card.

5. A card substantially as herein described with reference to the accompanying drawings.

6. A card reader substantially as herein described with reference to the accompanying drawings.

Printed in the United Kingdom for
Her Majesty's Stationery Office, Dd 8818935, 1986, 4235.
Published at The Patent Office, 25 Southampton Buildings,
London, WC2A 1AY, from which copies may be obtained.