

Nov. 20, 1951

F. T. HILLIKER

2,575,493

DISHWASHING MACHINE AND PLURAL LIQUID SPRAY MEANS THEREFOR

Filed May 28, 1949

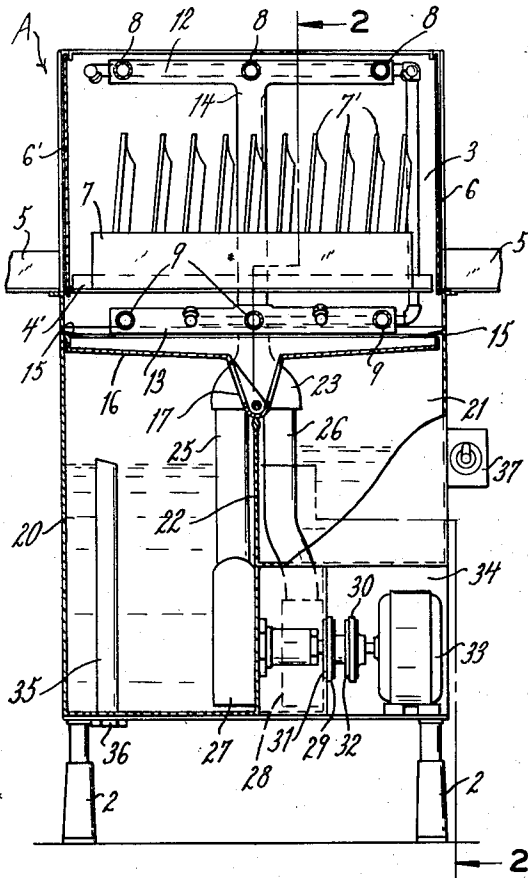

FIG. 1.

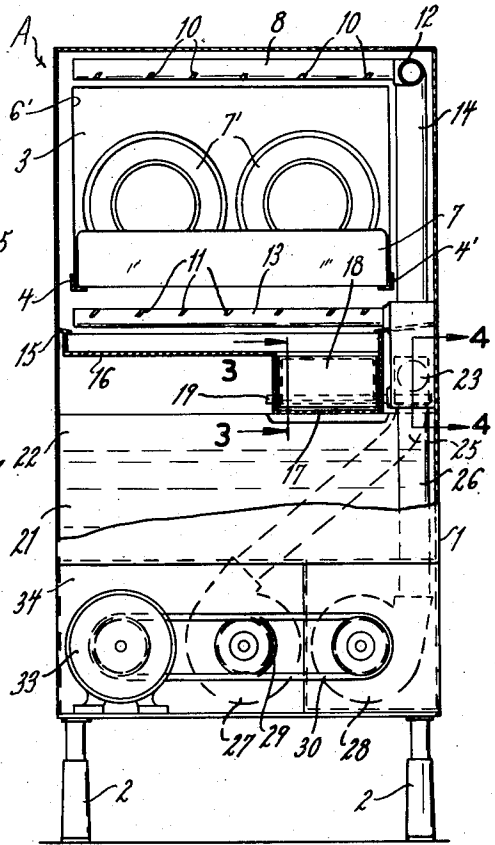

FIG. 2.

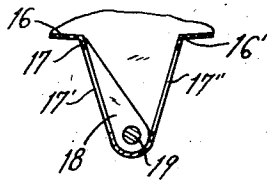

FIG. 3.

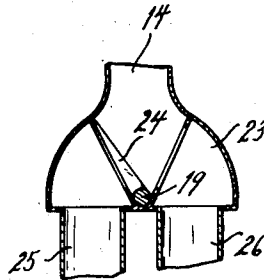

FIG. 4.

INVENTOR
FRANK T. HILLIKER

BY

Alfred W. Petch

ATTORNEY

UNITED STATES PATENT OFFICE

2,575,493

DISHWASHING MACHINE AND PLURAL LIQUID SPRAY MEANS THEREFOR

Frank T. Hilliker, St. Louis, Mo.

Application May 28, 1949, Serial No. 96,076

4 Claims. (Cl. 134—96)

1 This invention relates in general to certain new and useful improvements in dishwashing machines.

The primary object of the present invention is to provide a dishwashing machine which is compact in size and economical in cost of construction.

It is another object of the present invention to provide a dishwashing machine which is unusually economical in operation and is capable of using rinse water containing a dish-sterilizing agent so that the excessive and wasteful use of large quantities of extremely hot water, as hitherto required, may now be obviated.

It is also an object of the present invention to provide a dishwashing machine adapted for performing successive washing and rinsing operations in the same chamber without intermixture of the washing and rinsing solutions and particularly without contamination of the rinse water by wash water.

It is a further object of the present invention to provide a dishwashing machine embodying valve means actuated by pressure imparted to the washing and rinsing solutions for circulating the solutions through the machine returning same to their respective tanks of origin.

It is an additional object of the present invention to provide dishwashing machines having means for effecting washing and rinsing operations in timed sequence.

With the above and other objects in view, my invention resides in the novel features of form, construction, arrangement, and combination of parts presently described and pointed out in the claims.

In the accompanying drawing—

Figure 1 is a front sectional view of a dishwashing machine constructed in accordance with and embodying the present invention;

Figure 2 is a sectional view taken along lines 2—2 of Figure 1; and

Figures 3 and 4 are fragmentary sectional views taken along lines 3—3 and 4—4, respectively, of Figure 2.

Referring now in more detail and by reference characters to the drawing which illustrates a preferred embodiment of the present invention, A designates a dishwashing machine comprising a cabinet 4, preferably rectangularly shaped, and supported at its lower corners by legs 2. The upper portion of the cabinet 4 is adapted to provide an enclosed chamber 3 having a pair of transversely extending parallel tracks 4, 4', fabricated of angle iron and communicating at

2 either end with conventional service tables 5 through doors 6, 6', mounted in the opposite side walls of the chamber 3 for vertical sliding movement whereby conventional dishwashing racks 7 containing soiled tableware 7' may be easily inserted therein and removed therefrom.

Provided within the chamber 3 adjacent the top and bottom is a plurality of spray or distributing pipes 8, 9, respectively, disposed for ejecting fluid onto the dishes from above and below through orifices 10, 11, respectively. The pipes 8, 9, are connected at their forward ends to transversely extending heads or manifolds 12, 13, respectively, which are in turn connected to a vertically disposed riser 14. Provided at the lower end of the chamber 3 and extending inwardly from the side walls thereof is a flange 15 to the underface of which is suitably secured, as by welding, the upper margins of a drain or catch plate 16, which extends across the chamber 3 and forms the bottom thereof. Said plate 16 inclines or slopes downwardly toward its center, as at 16'. Opening upwardly into the rearward central portion of the drain plate 16 is a V-shaped drain valve 17 having its sides open in the formation of discharge ports 17', 17'', and is provided with a deflector or flapper member 18 mounted upon a rock shaft 19 journaled in and extending through the end walls of the valve 17, said deflector member 18 is thereby adapted, upon rotation of the shaft 19, to rest optionally closure-wise across one or the other of the ports 17', 17'', for directing drainage through the open port 17', or 17'', as the case may be, and into one or other of two supply tanks 20, 21, into which the drain valve 17 opens through the ports 17', 17'', respectively, said tanks 20, 21, being provided in the bottom portion of the cabinet 4 by the division thereof by a centrally disposed transversely extending wall 22.

Adjacent the rearward end of the drain valve 17, the riser 14 is connected to a double check valve 23, in horizontal alignment with the drain valve 17 and provided with a deflector or flapper member 24 mounted on the forward end of the rock shaft 19 which extends through the valve 23 and is journaled in the walls thereof. It will thus be seen that the deflectors 18, 24, will, upon rotation of the rock shaft 19, swing in unison in the same direction. Communicating with each side of the valve 23 are pipes or risers 25, 26, which extend downwardly into the supply tanks 20, 21, respectively. Each of said pipes 25, 26, is connected at its lower end to pumps 27, 28, preferably of the centrifugal type, which are supported upon the bottom wall of the cabinet 4 and are each re-

spectively connected by belts 29, 30 to unidirectional drive-clutches 31, 32, directly on the shaft of an electric reversible motor 33. The clutches 31, 32, are arranged oppositely to each other so that when the motor 33 is running in one direction the clutch 31 will transmit movement and the clutch 32 will not and conversely when the motor 33 is running in the other direction the clutch 32 will transmit motion and the clutch 31 will not. Preferably, the electric motor 33 should be disposed within a water-tight compartment 34 provided beneath the tank 21 in the base of the cabinet 1.

Disposed within the tank 20 for maintenance of the level of fluid therein is an upstanding overflow pipe 25 connected at its lower end to a drain 36 in the base of the cabinet 1.

A conventional timing switch 37 is provided for cyclically reversing direction of the motor 33 for alternate engagement of the pumps 27, 28 in timed sequence.

In operation, the tanks 20, 21, are respectively supplied with a quantity of washing solution of requisite detergent strength and chemically treated rinse water. The tray 7 of soiled tableware 7' is then moved, as by pushing, along the table 5 through the door 6 and into the chamber 3 whereupon the doors 6, 6', are closed, the motor 33 started by setting the switch 37 at its central position. The motor 33 will rotate in such direction as will cause motion to be transmitted through the clutch 31 for actuation of the pump 27 whereby washing solution is forced upwardly through the pipe 25 and into the valve 23. If the deflector plate 24 is disposed blockingly across the side of the valve 23 communicating with the upper end of the pipe 25, the force with which the washing solution is being impelled upwardly will cause the deflector plate 24 to be swung away from the pipe 25 and into closure-wise disposition across the upper end of the pipe 26. Thereby opening the valve 23 for the washing solution and simultaneously preventing any of the washing solution from entering the tank 21 through the pipe 26. Upon such swinging movement of the deflector 24, the deflector 18 of the drain valve 17 will be correspondingly swung into position across the port 17' thereof, thus directing drain fluid back into the tank 20 and preventing any flow into the tank 21. The washing solution will continue its course upwardly through the riser 14, along the manifolds 12, 13, thence along the pipes 8, 9, and outwardly onto the tableware through the orifices 10, 11. The washing solution will drain downwardly, onto the drain pipe 16, thence into the valve 17 and will flow through the port 17' for return to its tank of origin 20. Thus, it will be seen that throughout the entire operation none of the washing solution entered the tank 21 for dilution and contamination of the rinse water.

The washing cycle continues for the selected interval to which the timing mechanism of the switch 37 is set and upon the completion of such interval the switch 37 will automatically reverse the motor 33, thereby causing the clutch 31 and its associated pump 27 to stop. At the same time the clutch 32 and its associated pump 28 starts rotating, forcing rinse water upwardly through the pipe 26, causing the deflector 24 to swing in the opposite direction for effectively blocking the opening to the upper end of the pipe 25. Simultaneously, the deflector 18 is swung closure-wise across the port 17', whereby, the rinse water,

upon drainage, will be directed back into its tank of origin 21.

The rinsing cycle will continue, in turn, for the selected interval to which the switch 37 is set, and at the completion of such interval the motor 33 will be shut off entirely. The tray 7 may then be pushed outwardly through the opposite door 6' and the dishes allowed to drain. The chamber 3 is, of course, now ready to receive another trayful of dirty dishes for a subsequent wishing and rinsing operation.

If desired, the motor 33 may be operated manually for alternate engagement of the pumps 27, 28.

Thus it will be seen that throughout continued usage of the machine A the solutions will be kept totally distinct without any danger of impairment of their respective strength by admixture with the other.

It should be understood that changes and modifications in the form, construction, arrangement, and combination of the several parts of the dishwashing machine may be made and substituted for those herein shown and described without departing from the nature and principle of my invention.

Having thus described my invention, what I claim and desire to secure by Letters Patent is:

1. A dishwashing machine comprising first and second tanks adapted to receive fluids, said machine having a chamber for reception of tableware, spray members provided in said chamber, a conduit member connecting said spray members with each of said first and second tanks, fluid lifting means associated with each of said tanks, a valve having a rockable closure element adapted to swing from a first position to a second position responsive to the pressure imparted to the fluids by the fluid lifting means for permitting passage through the conduit member of fluid from one or the other of said tanks a drain plate located beneath the chamber having two openings respectively discharging to the first and second tanks, movable closure means for optionally blocking one or the other of said openings, and actuating means operatively connecting said closure means and the rockable closure element so that the closure means is moved into one or the other of its positions by corresponding movement of the rockable closure element.

2. A dishwashing machine comprising first and second tanks adapted to receive fluids, said machine having a chamber for receiving tableware, spray members provided in said chamber, a riser connected to said spray members, conduit members respectively connected to said first and second tanks, fluid lifting means associated with each of said tanks, a valve member interposed between the riser and conduit members, a rockable closure element swingably mounted in said valve for optional movement into one or the other of two positions responsive to the pressure imparted to the fluids by their respective lifting means so that when fluid from one tank is flowing through one conduit member the closure element will assume one position and when fluid is flowing through the other conduit member the closure element will assume the other position, a drain plate located beneath the chamber having two openings respectively discharging to the first and second tanks, a deflector for optionally blocking one or the other of said openings, and a shaft operatively connecting said deflector and the rockable closure element so that the deflector is moved into one or the other of its

5

positions by corresponding movement of the rockable closure element.

3. A dishwashing machine comprising first and second tanks adapted to receive fluids, said machine having a chamber for receiving tableware, spray members provided in said chamber, a conduit member connecting said spray members with each of said first and second tanks, a drain plate disposed in said chamber, a drain valve housing provided in said drain plate, said drain valve having discharge ports opening into said first and second tanks, fluid lifting means associated with each tank, an inlet valve housing disposed between the spray members and the first and second tanks, a shaft extending through said drain valve housing and inlet valve housing, a first deflector member mounted on said shaft and disposed within the drain valve housing for optional positioning across one or the other of said ports, a second deflector member mounted on said shaft and disposed in said inlet valve housing, the second deflector member being actuated for swinging movement by the pressure imparted to the fluids by the respective fluid lifting means whereby the fluids may independently be circulated through the machine and at the same time the first deflector member may be correspondingly positioned so that fluids will be returned to their tanks of origin.

4. A dishwashing machine comprising first and second tanks disposed in substantially contiguous side-by-side relationship, a chamber disposed above and extending across both tanks, said chamber being adapted for receiving tableware, spray members provided in said chamber, a riser connected to said spray members, conduit members respectively connected to said first and second tanks, pumps associated with each of said tanks and respectively connected to the conduit members, a valve member interposed between the riser and conduit members and positioned in a position approximately intermediate between the two tanks, a rockable closure element swingably mounted in said valve for optional movement into one or the other of two positions respective-

6

ly by the pressure imparted to the fluids by the respective pumps so that when fluid from one tank is flowing through one conduit member the closure element will assume one position and when fluid is flowing through the other conduit member the closure element will assume the other position, a drain plate located beneath the chamber and above the tanks, said drain plate having a bottom wall which is inclined from its outer margins toward a central area, which central area is located approximately above the two tanks in the region of their contiguity, a depending sump-like drain chamber located in and forming a part of such central area of the drain plate, said drain chamber having two discharge openings one communicating with one tank and the other communicating with the other tank, a deflector plate rockably mounted in the drain chamber for optionally closing one or the other of said openings, and a shaft rigidly mounted to the deflector and the rockable closure element of the valve so that the movement of the closure element will actuate the deflector member so that when fluid is being pumped from one tank the deflector will be so positioned that the drain opening communicating with such tank will be open and the fluid will drain back into the tank of origin.

FRANK T. HILLIKER.

REFERENCES CITED

The following references are of record in the file of this patent:

UNITED STATES PATENTS

Number	Name	Date
1,656,139	Breton	Jan. 10, 1928
1,662,496	Forsgard	Mar. 13, 1928
2,044,921	Swanland	June 23, 1936
2,252,501	Foresman	Aug. 12, 1941

FOREIGN PATENTS

Number	Country	Date
544,010	Germany	Feb. 12, 1932