

Sept. 22, 1970

A. E. BEER
BEDCLOTHES

3,530,487

Filed Dec. 29, 1967

2 Sheets-Sheet 1

FIG. 1

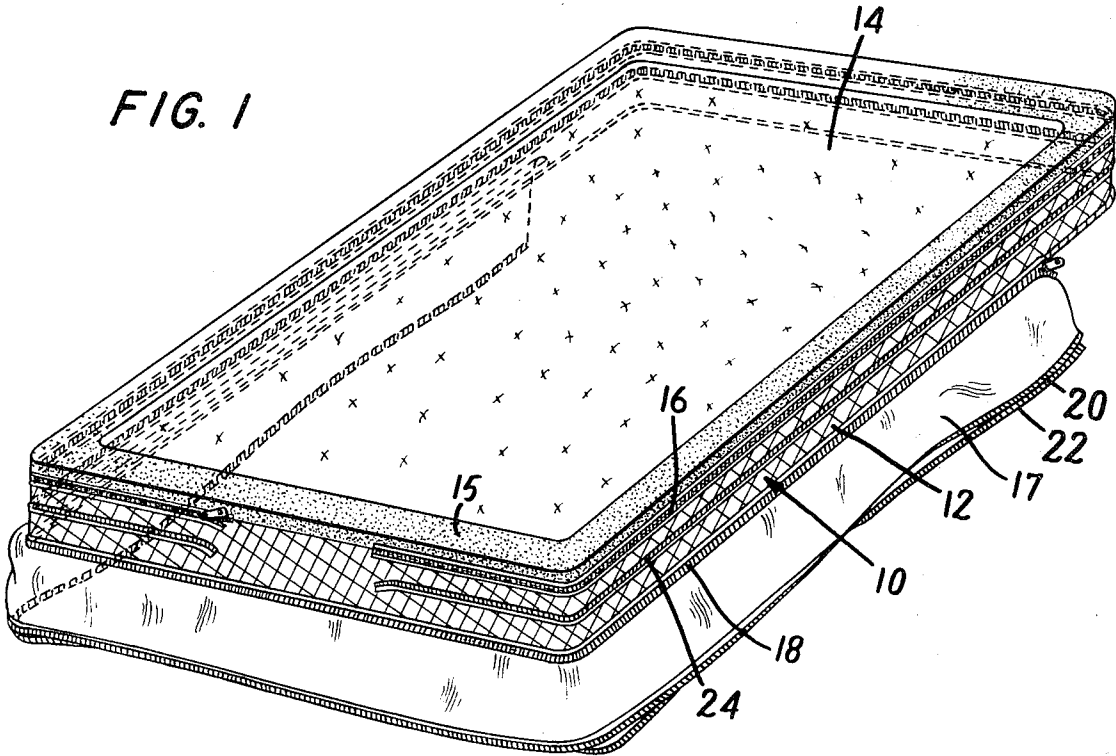
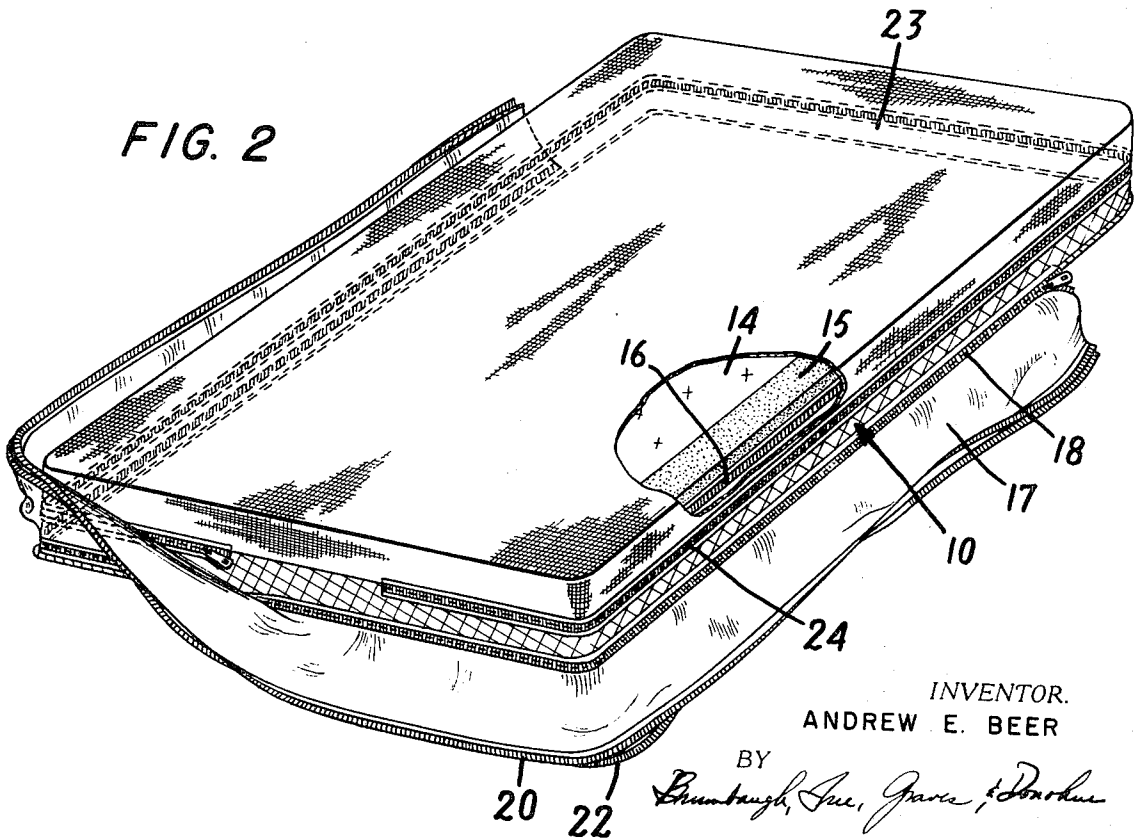

FIG. 2



INVENTOR.
ANDREW E. BEER

BY

Brunbaugh, Saxe, Jarvis & Donohue

his ATTORNEYS

Sept. 22, 1970

A. E. BEER

3,530,487

BEDCLOTHES

Filed Dec. 29, 1967

2 Sheets—Sheet 2

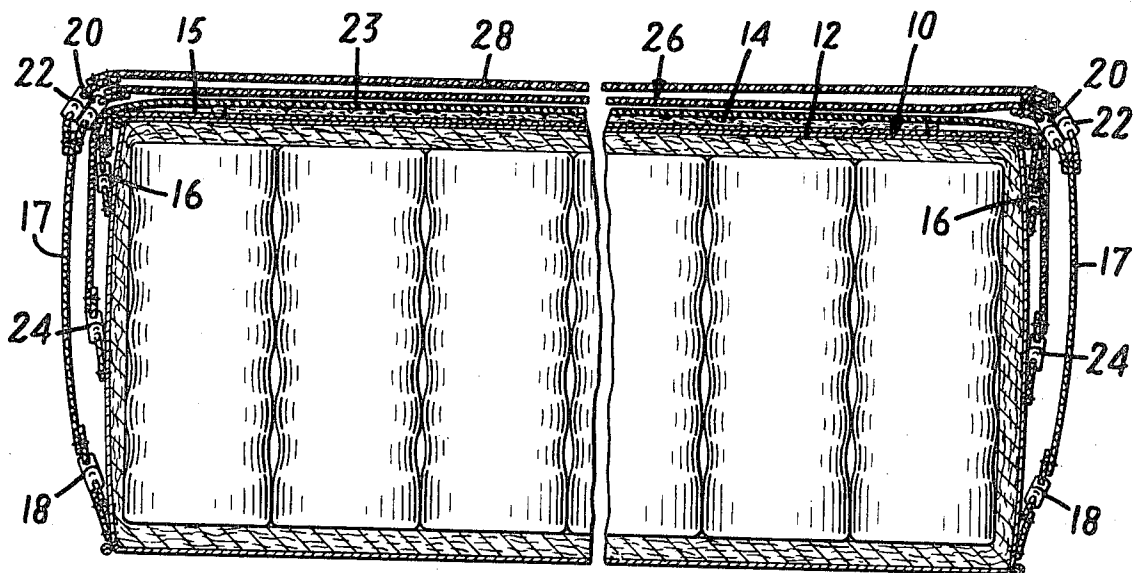
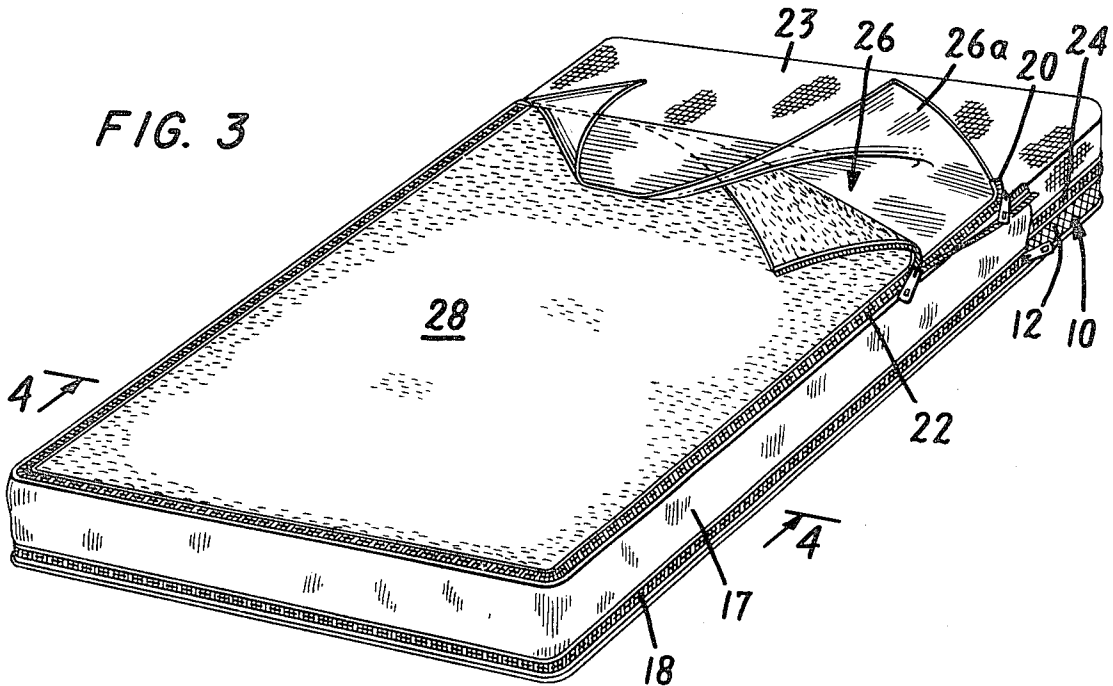

FIG. 4

INVENTOR.
ANDREW E. BEER

BY
Brunbaugh, Free, Jones & Prushke
his ATTORNEYS

1

2

3,530,487

BEDCLOTHES

Andrew E. Beer, New York, N.Y., assignor to Venture-vest Corp., Morris Plains, N.J., a corporation of Delaware

Filed Dec. 29, 1967, Ser. No. 694,687

Int. Cl. A47g 9/00

U.S. Cl. 5—334

13 Claims

ABSTRACT OF THE DISCLOSURE

A bed is more readily made up, or remade after use, and the sleeper's comfort is considerably enhanced by the use of bedclothes which are releasably fastened to the mattress, the bottom sheet being releasably fastened about substantially the entire perimeter of the mattress and the top sheet and blanket being releasably fastened to the mattress along the foot end and the major portions of the sides. The top sheet and blanket are normally held in close conformity to the mattress top surface but are rendered displaceable to accommodate the sleeper by elastic elements, such as a band of elastic fabric, interposed between and joining the edges of the top sheet and blanket and mattress.

BACKGROUND OF THE INVENTION

This invention relates to the bedclothes which facilitate making up the bed, both initially and after use, and which improve the comfort of the user.

Conventional bedclothes comprise bottom and top sheets and a blanket, all of which are usually simple rectangular fabric webs and are made up on a mattress by simply tucking appropriate edges under the mattress. In recent years, so-called fitted sheets have come into increasingly wider use and offer the advantage over conventional sheets of being retained on the mattress more securely. Conventional sheets are prone to being pulled out, particularly by active or restless sleepers who toss and turn or even thrash about in their sleep. With restless sleepers, the bed must sometimes be entirely remade after each use, which is a considerable disadvantage and irritation to the homemaker who performs the daily chore of making the beds. Moreover, the simple conventional sheets and blankets, because they are readily pulled out from under the mattress, frequently come off during the night and detract from the comfort, and may even endanger the health, of the sleeper. Young children are particularly prone to kicking off bedclothes during the night, but many adults experience restless nights when they toss and turn and consequently throw off the bedclothes. In hospitals and other institutions, there are often patients who are partially incapacitated and are unable to properly position their bed clothes if they should fall off.

There have been various proposals for fastening bedclothes to beds to facilitate making up and remaking the bed and to retain the bedclothes in position on the user. Many of these proposals involve particularly the bottom sheet, but some have been directed to the top sheet and blanket. In some instances, snaps or hooks are employed for attaching relatively widely spaced portions of a sheet or blanket to the bed. Although these proposals may provide some benefit, they still do not prevent a substantial amount of displacement of the bedclothes and do not appreciably facilitate the job of making up and remaking the bed. Thus, prior proposals have met with little acceptance.

SUMMARY OF THE INVENTION

There are provided, in accordance with the invention, novel and improved bedclothes which facilitate making

up and remaking the bed and enhance the sleeper's comfort by retaining all portions of the bedclothes in proper position regardless of how much tossing and turning about the sleeper does while still permitting the sleeper to assume any position that may be comfortable for him and to shift position freely. More particularly, the bedclothes, according to the invention, comprise a bottom sheet which is releasably fastened to the mattress about substantially its entire perimeter and a top sheet and blanket, each of which is releasably fastened to the mattress along the foot end and along the major portions of the sides of the mattress.

An important feature of the invention is the provision of elastic elements for joining the top sheet and blanket to the mattress. Preferably, the elastic elements are constituted by a band of elastic fabric of substantial width joined along one edge to the mattress and adjacent the other edge to the top sheet and blanket.

Various forms of releasable fastenings can be used, including zippers, rows of snap fasteners, hook fasteners, buttons, "Velcro" or any other appropriate releasable fastener. It is desirable, however, to employ continuous fasteners, such as zippers or "Velcro" or to closely space snap or hook fasteners so that substantially continuous joiinder between the bed clothes and the mattress is provided. In general, the continuous forms of fasteners, such as zippers or "Velcro," are preferred, inasmuch as they are more easily joined and released than are rows of snaps or hooks. However, the use of buttons, snaps, hooks, or other similar types of fasteners may find use, particularly in certain parts of the bedclothes that are required to be detached only relatively infrequently.

For example, the bedclothes will generally include a protective pad on the mattress and underlying the bottom sheet, and the protective pad may well be attached to the mattress by means of relatively widely spaced snaps, buttons or hooks. The types of releasable fasteners employed in the bedclothes may also be varied among the several elements of the bedclothes or parts of those elements.

The bottom sheet is preferably joined to the mattress about substantially its entire perimeter, although gaps may appropriately be left at say the foot end where the bottom sheet is unlikely to come out. Similarly, where a protective pad is provided, it is joined about substantially the entire mattress perimeter. On the other hand, the top sheet and blanket are joined only along the foot end and along the major portions of the sides of the mattress.

The elements or parts of the fasteners that are secured to the mattress may be secured directly to the mattress upholstery fabric itself. Alternatively, the bedclothes, in the form that they might be sold commercially, may include a removable mattress cover which encloses the entire mattress and to which one of the parts of the fasteners is secured.

The elastic strips or other elastic elements by which the top sheet and blanket are attached to the mattress may be of various materials, many of which are well known in the art and are commercially available. If the elastic material is of a type that tends to become relatively permeable to air when in stretched condition, it is desirable to provide a band of suitable non-air permeable material to block off entry into the bed of drafts that might otherwise come through the elastic band when it is stretched. The non-permeable band may be joined to the elastic band adjacent the upper longitudinal edge of the elastic band and underlie the major portion of the elastic band, although, of course, it should be attached only at one longitudinal edge so that it does not impede the elastic action of the elastic band. The width of the elastic band may vary along its length in a manner providing a greater degree of

stretching at certain portions, such as those portions laterally of the arms and legs of the user, thereby to facilitate the movements of the user by providing for greater displacement of the top sheet and blanket in those portions which are stretched to a greater extent as the user changes position.

Both the bottom and top sheets may be of the fitted type in which the corners are formed with seams that shape them to conform to the mattress corners.

In use, the releasable fasteners by which the several elements of the bedclothes are joined to the mattress facilitate making up the bed initially by making it unnecessary to tuck the bedclothes under the mattress and by automatically locating the bedclothes in proper position on the mattress. When the sleeper leaves the bed after use, the elastic elements pull the top sheet and blanket back into proper position, and only relatively simple, quickly performed operations are required to smooth out and straighten the bed. The pad and bottom sheet remain substantially undisturbed in position on the mattress and require no repositioning or tucking in when the bed is made after use.

The releasable elements permit the top sheet and blanket to be released from the mattress along one side or a portion of one side to permit the user to enter and leave the bed, and they may then be refastened. If the room is warm and the blanket or both the blanket and sheet are not needed, they can be released along the sides and turned down over the foot end of the bed.

Because the bedclothes are attached to the mattress, the important further advantage of providing greater comfort for the user is obtained—the top sheet and cover cannot be pulled out or kicked off inasmuch as they are joined to the mattress at the foot end and along the major portions of the sides of the mattress. This is of considerable importance for sleepers who are prone to tossing and turning, as well as to children, many of whom are characteristically likely to kick off their covers during the night. Because of the advantages of the bedclothes, they will find wide use not only in the home, where they simplify the work of the homemaker and provide better sleeping conditions for the residents, but also in hospitals and other institutions, for example, homes for aged, where these advantages affect the costs of operating the institution and the welfare of the patients.

DESCRIPTION OF THE DRAWINGS

For a better understanding of the invention, reference may be made to the following description of an exemplary embodiment, taken in conjunction with the figures of the accompanying drawings, in which:

FIG. 1 is a pictorial view of a mattress partially made up with a protective pad and an elastic band in place;

FIG. 2 is a pictorial view of the partially made up mattress of FIG. 1 after the bottom sheet has been fastened to it;

FIG. 3 is a pictorial view showing the mattress after the top sheet and blanket have been added; and

FIG. 4 is an end view in cross-section of the mattress as fully made up with bedclothes, the view being taken generally along a plane represented by the lines 4—4 and in the direction of the arrows.

DESCRIPTION OF EXEMPLARY EMBODIMENT

Referring first to FIG. 1, the bedclothes of the invention are appropriate for a mattress, which is designated generally by the reference numeral 10, of any suitable construction, including any form of inner-spring type (as shown) as well as those of foam rubber, polyurethane or other materials. Normally, the mattress will be upholstered with a cover 12 of mattress ticking or other suitable material that is fabricated with the mattress by the manufacturer. The mattress cover 12 may be provided with the releasable fasteners (described below), which may be installed by the manufacturer or by the user. Alternatively, a supplemental mattress cover, which may be

considered as generally equivalent to the cover 12, may be provided and will incorporate the fasteners by which the bedclothes are secured to the mattress.

In the embodiment shown in the drawings, the bedclothes include a protective pad 14, which may be of the usual quilted fabric often used for his purpose, rubberized material, a plastic film or any other relatively non-permeable protective material, or a combination of appropriate materials. The pad 14 is generally rectangular in shape and is of a length and width conforming closely to those of the mattress. In the embodiment, the pad is stitched to a sheet 15 of appropriate material, the edges of which extend beyond the perimeter of the pad and turn down around the sides and the foot and head ends of the mattress. The pad 14 is joined to the mattress by the sheet 15 along a line extending substantially around the perimeter of the mattress and spaced a short distance below the upper peripheral edge in a manner firmly holding it in place on the mattress. In the form illustrated in the drawings, the releasable fastener is a zipper 16, but other fasteners can readily be substituted, as mentioned above.

Joined to the mattress adjacent its lower peripheral edge is a band 17 of elastic material, the elastic material being of any suitable form, which extends along the foot end and the major portions of the sides of the mattress. The elastic band 17 is joined by a releasable fastener, such as a zipper 18, one element of which is joined to the mattress cover 12, or to the equivalent supplemental, removable cover if one is provided. The width of the band 17 is preferably on the order of the same dimension as the depth of the mattress 10 so that its upper edge is generally coincident with the upper peripheral edge of the mattress. Joined along the upper edge of the band 17 are one element of each of two zippers 20 and 22 by which the top sheet and blanket (described below) are secured to the band 17 and thereby to the mattress.

Where the elastic material used in the band is of a type that opens up and becomes somewhat permeable to air when in stretched condition, it is desirable to provide a supplemental strip (not shown) of relatively non-permeable material generally overlying the inner face of the band 17 (when the band is in place on the mattress) and joined along its upper edge to the free or upper edge of the elastic band 17. Such a strip of material, which, of course, should not be secured to the elastic band other than at the upper edge so as to not restrict the elastic action of the elastic band 17, keeps out drafts that might otherwise enter the bed when the elastic band is stretched.

Referring next to FIG. 2, a bottom sheet 23, which is preferably fitted at the corners to conform to the mattress, is releasably fastened to the mattress by means of a zipper 24 that extends substantially about the entire perimeter of the mattress and is located intermediate the zipper 16 and the lower peripheral edge of the mattress. The zipper 24 holds the bottom sheet 23 in position on the mattress so that any substantial displacement of it relative to the mattress is precluded. In FIG. 2, a portion of the bottom sheet 23 is cut away to show that it overlies the protective pad 14.

Turning now to FIG. 3, a top sheet 26, which overlies the bottom sheet 23, is fastened by the zipper 20 to the elastic band 17 and is thus releasably fastened to the mattress. The top sheet 26 is of an ample length so that it includes a free end 26a (shown folded back in FIG. 3) that extends somewhat beyond the end of the elastic band 17 at the head end of the bed, the ends of the band 17 being located such that the sheet and blanket will overlie the user's body but leave a place for the pillow and the user's head. It is desirable that the zipper 20 be of the type that opens at both ends so that it can be worked from either side of the bed to release an end portion of the sheet to facilitate entering and leaving the bed. Two separate zippers might also be used.

Overlying the top sheet 26 is a blanket 28 which is of substantially the same width as the sheet but will

generally not have an end extension portion and will terminate where the elastic band 17 ends. The blanket 28 is joined to the mattress, through the elastic band 17, by the zipper 22, and as in the case of the zipper 20 by which the sheet is joined to the mattress, the zipper 22 may be of the type that is releasable from both ends or may be constituted by two separate zippers, one along each side of the mattress.

As mentioned previously, portions of the zippers, or in fact each complete zipper, may be replaced by other appropriate forms of releasable fasteners, such as strips of "Velcro" material, snaps, buttons, hooks, and other types of releasable fasteners. The materials, dimensions and geometric forms of the elements of the embodiment are also subject to numerous variations and modifications, as will readily be apparent of those skilled in the art.

In use, the bed is made up generally in the order depicted by each figure of the drawings, taken in order according to figure number. First of all, the protective pad 14 is positioned and the zipper 16 closed to secure the pad to the mattress. The elastic panel 16 is then installed on the mattress, followed by installation of the bottom sheet 23, top sheet 26, and blanket 28, in that order. The use of zippers, or other forms of releasable fastener, considerably facilitates making up the bed, inasmuch as it is unnecessary to tuck the bedclothes under the mattress, to make any corner folds, or to carefully position and straighten the various elements to locate them properly on the mattress. Each element is accurately positioned and quickly and easily fastened to the mattress by means of the releasable fastener. Zippers provide very quick and easy fastening and are therefore generally preferred.

To permit the bed to be entered or left, the top sheet and blanket may be freed along a portion of one edge by partially unzipping the zippers 20 and 22 so that a portion adjacent the head ends of the top sheet and blanket can be folded back. After the user enters the bed, the zippers can readily be re-closed, thereby repositioning the top sheet and blanket in secured position. When the user is in bed, the elastic band 17 stretches and permits the top sheet and blanket to be displaced to accommodate the user comfortably. Nonetheless, the top sheet and blanket are firmly retained in position and cannot be kicked off and cannot fall off during the night.

When the user leaves the bed, very little is necessary to remake the bed beyond closing the zippers 20 and 22 which will have been partially opened to permit the user to leave the bed and, possibly, minor smoothing out of the blanket and top sheet to leave the bed neat and ready for the next use.

The embodiment of the invention illustrated in the drawings and described above is intended to be merely exemplary, and those skilled in the art will be able to make numerous variations and modifications of it without departing from the spirit and scope of the invention. All such variations and modifications are intended to be included within the scope of the invention as defined in the appended claims.

I claim:

1. Bedclothes for a mattress comprising a bottom sheet overlying the mattress top surface, releasable fastening means joining the bottom sheet to the mattress about substantially the entire perimeter thereof for minimum displacement of any part of the bottom sheet relative to the mattress, an elongated band of elastic material of substantial width extending continuously about the foot end and at least the major portions of the sides of the mattress and joined adjacent one longitudinal margin to the mattress, a top sheet overlying the bottom sheet, releasable fastening means joining the top sheet to the elastic band adjacent the second longitudinal margin thereof, a blanket overlying the top sheet, and releasable fastening means

joining the blanket to the elastic band adjacent the second longitudinal margin thereof.

2. Bedclothes according to claim 1 wherein the respective means releasably joining the top sheet and blanket to the elastic band include zippers extending closely adjacent each other along generally concurrent lines adjacent the second longitudinal margin of the elastic band.

3. Bedclothes according to claim 1 wherein the width of the elastic band is generally equal to the depth of the mattress and the lower longitudinal margin of the elastic band is joined to the lower peripheral edge of the mattress.

4. Bedclothes according to claim 1 further comprising a protective pad overlying the mattress surface and underlying the bottom sheet, and releasable fastening means joining the protective pad to the mattress about substantially the entire perimeter thereof for minimum displacement of any part of the pad relative to the mattress.

5. Bedclothes according to claim 1 wherein the bottom sheet is releasably joined to the mattress along a line intermediate the upper and lower peripheral edges of the mattress.

6. Bedclothes according to claim 3 wherein the lower longitudinal margin of the elastic band is releasably joined to the mattress.

7. Bedclothes according to claim 4 wherein the protective pad is releasably joined to the mattress along a line spaced closely from and below the upper peripheral edge of the mattress and the bottom sheet is joined along a line intermediate the line of joinder between the pad and the mattress and the lower peripheral edge of the mattress.

8. Bedclothes according to claim 7 wherein the means releasably joining the pad and bottom sheet to the mattress includes zippers.

9. Bedclothes for a mattress comprising a protective pad overlying the mattress top surface, releasable fastening means joining the protective pad to the mattress about substantially the entire perimeter thereof for minimum displacement of any part of the pad relative to the mattress, the joinder being along a line closely spaced from and below the upper peripheral edge of the mattress, a bottom sheet overlying the protective pad, means joining the bottom sheet to the mattress about substantially the entire perimeter thereof for minimum displacement of any part of the bottom sheet relative to the mattress, the joinder of the bottom sheet to the mattress being along a line intermediate the line of joinder between the pad and the mattress and the lower peripheral edge of the mattress, a band of elastic material of substantial width extending continuously about the foot end and at least the major portions of the sides of the mattress and joined along its lower longitudinal margin to the mattress along a line of joinder between the lower peripheral edge of the mattress and the line of joinder between the mattress and the bottom sheet, a top sheet overlying the bottom sheet, releasable fastening means joining the top sheet to the elastic band adjacent the upper edge thereof, a blanket overlying the top sheet, and releasable fastening means joining the blanket to the elastic band adjacent the upper edge thereof.

10. Bedclothes for a mattress comprising a protective pad overlying the mattress top surface, releasable fastening means joining the protective pad to the mattress about substantially the entire perimeter thereof for minimum displacement of any part of the pad relative to the mattress, the joinder being along a line closely spaced from and below the upper peripheral edge of the mattress, a bottom sheet overlying the protective pad, releasable fastening means joining the bottom sheet to the mattress about substantially the entire perimeter thereof for minimum displacement of any part of the bottom sheet relative to the mattress, the joinder of the bottom sheet to the mattress being along a line intermediate the line of joinder between the pad and the mattress and the lower

peripheral edge of the mattress, an elongated band of elastic material of width generally equal to the depth of the mattress and extending continuously about the foot end and at least the major portions of the sides of the mattress and releasably joined along its lower longitudinal margin to the mattress along a line of joinder between the lower peripheral edge of the mattress and the line of joinder between the mattress and the bottom sheet, a top sheet overlying the bottom sheet, releasable fastening means joining the top sheet to the elastic band adjacent the upper edge thereof, a blanket overlying the top sheet, and releasable fastening means joining the blanket to the elastic band adjacent the upper edge thereof.

11. Bedclothes according to claim 10 wherein the respective means releasably joining the pad and bottom sheet to the mattress include zippers.

12. Bedclothes according to claim 10 wherein the respective means releasably joining the top sheet and blanket to the elastic band include zippers extending closely adjacent each other along generally concurrent lines adjacent the upper longitudinal edge of the elastic band.

13. Bedclothes for a mattress comprising a protective pad overlying the mattress top surface, zipper fastening means releasably joining the protective pad to the mattress about substantially the entire perimeter thereof for minimum displacement of any part of the pad relative to the mattress, the joinder being along a line closely spaced from and below the upper peripheral edge of the mattress, a bottom sheet overlying the protective pad, zipper fastening means releasably joining the bottom sheet to the mattress about substantially the entire perimeter thereof for minimum displacement of any part of the bottom sheet relative to the mattress, the joinder of the bottom sheet

to the mattress being along a line intermediate the line of joinder between the pad and the mattress and the lower peripheral edge of the mattress, an elongated band of elastic material of width generally equal to the depth of the mattress and extending continuously about the foot end and at least the major portions of the sides of the mattress and releasably joined along its lower longitudinal margin to the mattress along a line of joinder between the lower peripheral edge of the mattress and the line of joinder between the mattress and the bottom sheet, a top sheet overlying the bottom sheet, zipper fastening means releasably joining the top sheet to the elastic band adjacent the upper edge thereof, a blanket overlying the top sheet, and zipper fastening means releasably joining the blanket to the elastic band adjacent the upper edge thereof and along a line generally concurrent with the zipper fastening means joining the top sheet to the elastic band.

References Cited

UNITED STATES PATENTS

2,516,363	7/1950	Block et al.	
2,528,313	10/1950	Kessler.	
2,789,292	4/1957	Budinquest.	
3,066,321	12/1962	Kintner.	
3,331,088	7/1967	Marquette	5—334

BOBBY R. GAY, Primary Examiner

A. M. CALVERT, Assistant Examiner

U.S. CI. X.R.

5—335