



US 20050230338A1

(19) **United States**

(12) **Patent Application Publication**
Farinola et al.

(10) **Pub. No.: US 2005/0230338 A1**

(43) **Pub. Date: Oct. 20, 2005**

(54) **MERCHANDISE DISPLAY FIXTURE**

(52) **U.S. Cl. 211/186**

(75) **Inventors: Nick Farinola, Kinnelon, NJ (US);
Eric Grassel, Basking Ridge, NJ (US);
Charles Babboni, Brick, NJ (US);
Larry Shelton, Shrewsbury, MA (US);
Cindy Buffi, Franklin, MA (US)**

(57) **ABSTRACT**

**Correspondence Address:
ALSTON & BIRD LLP
BANK OF AMERICA PLAZA
101 SOUTH TRYON STREET, SUITE 4000
CHARLOTTE, NC 28280-4000 (US)**

A fixture for displaying merchandise and a method are provided. The fixture includes a generally vertical back panel having opposed lateral edges and opposed top and bottom edges. The back panel defines at least one engageable member extending in a generally horizontal direction between the lateral edges. In addition, the fixture includes at least one generally vertical partition having at least one cooperative engaging member removably attached to the engageable member of the back panel. The vertical partition extends substantially between the top and bottom edges of the back panel, and further extends generally orthogonal from the back panel and generally orthogonal to the engageable member on the back panel. The vertical partition is advantageously slidable in a lateral direction to define variable lateral positions on the back panel.

(73) **Assignee: The TJX Companies, Inc.**

(21) **Appl. No.: 10/827,778**

(22) **Filed: Apr. 20, 2004**

Publication Classification

(51) **Int. Cl.⁷ A47F 5/08**

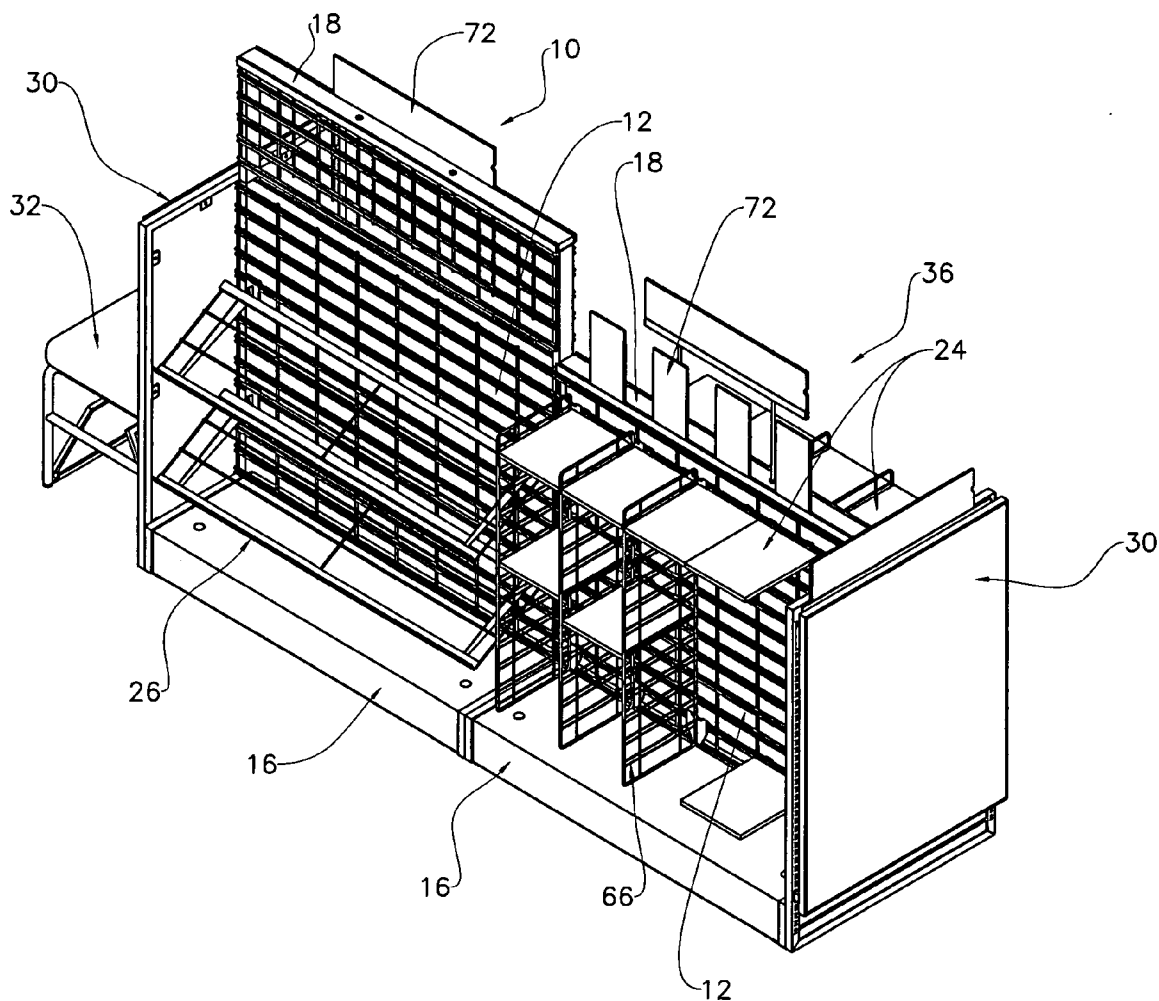

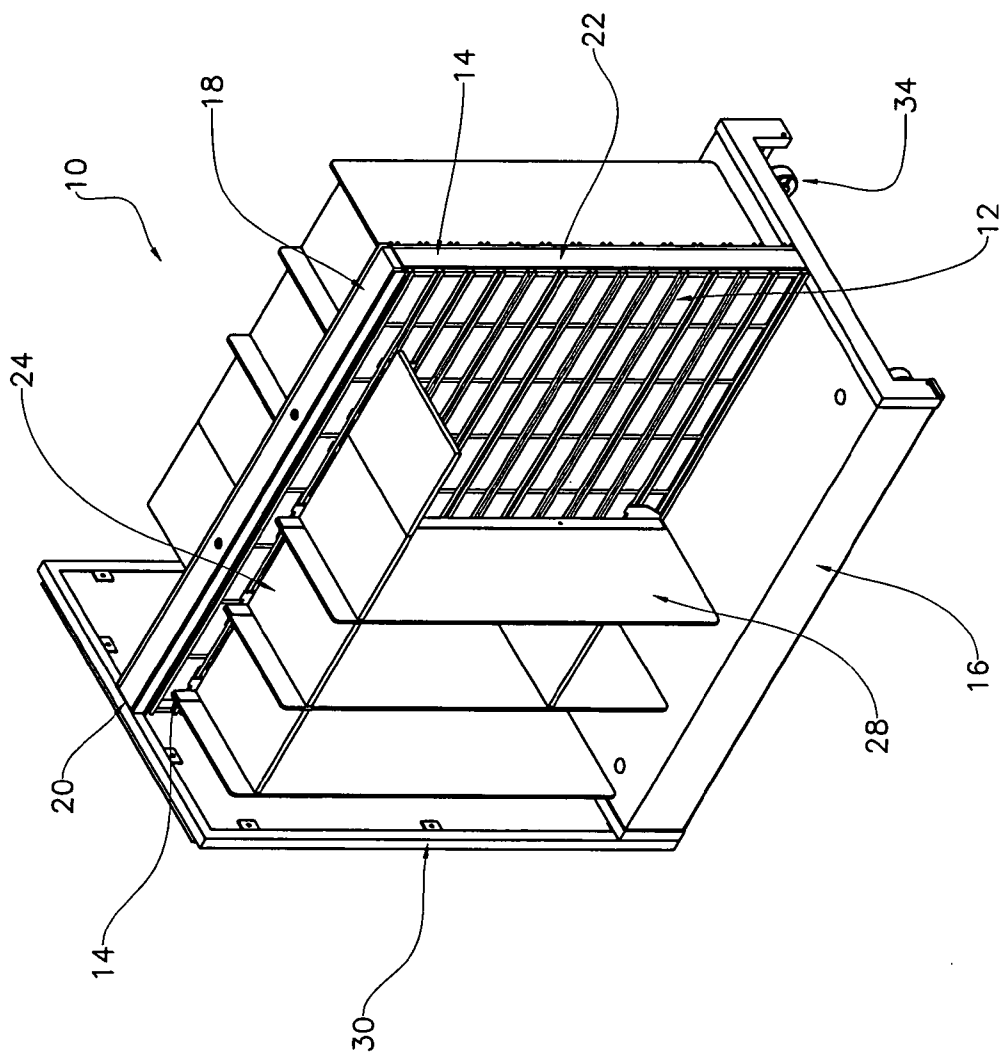

Figure 1

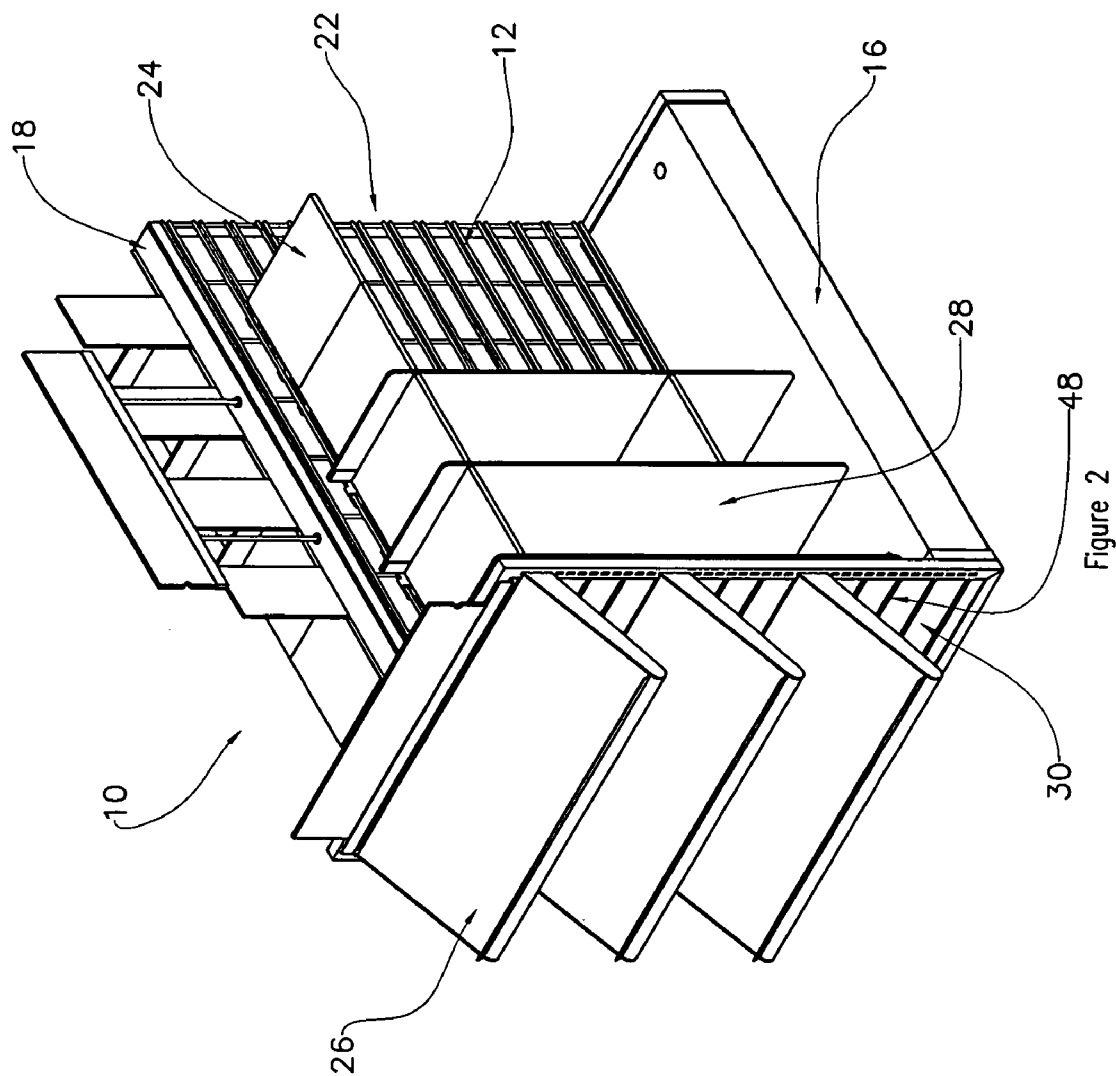

Figure 2

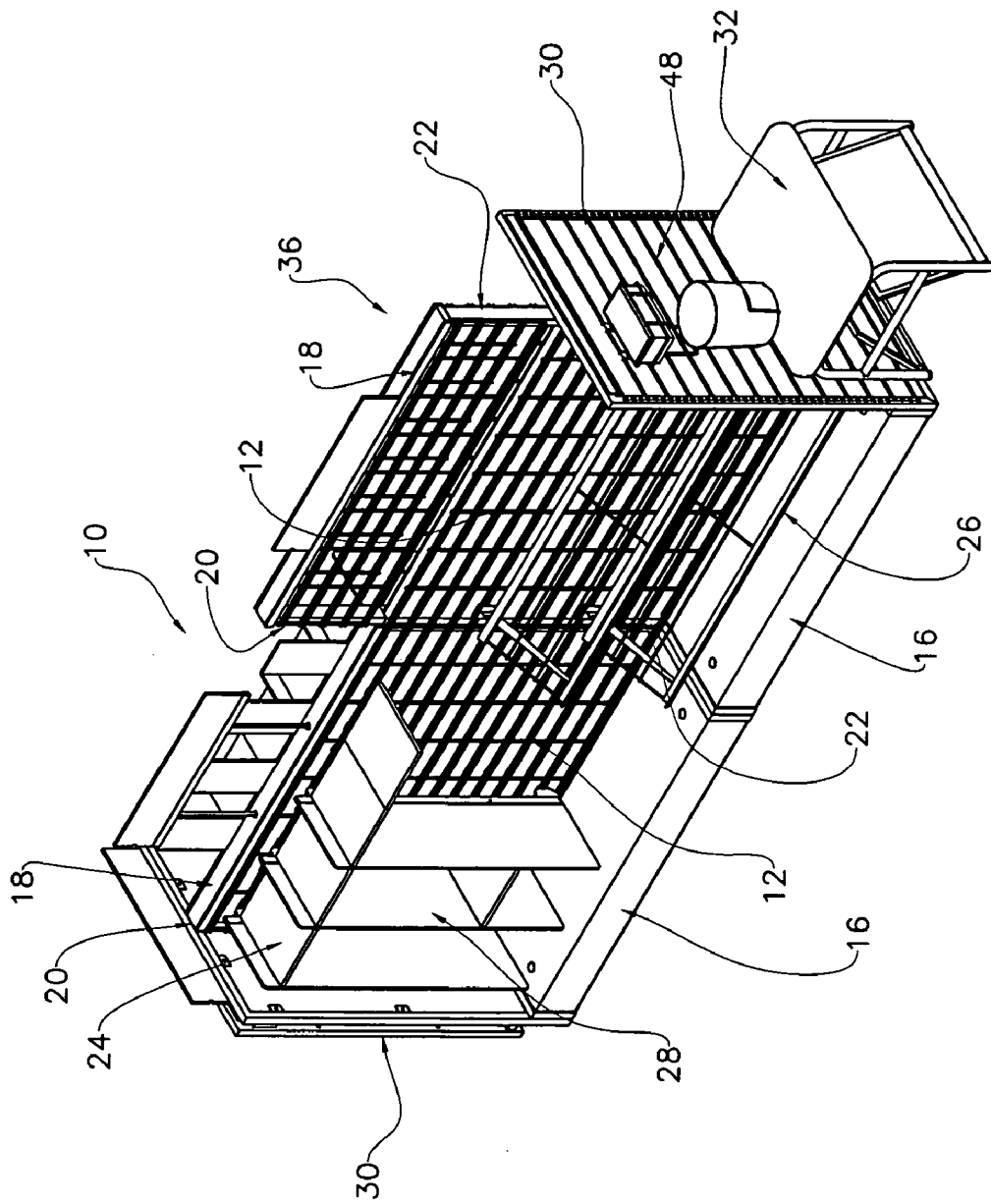

Figure 3

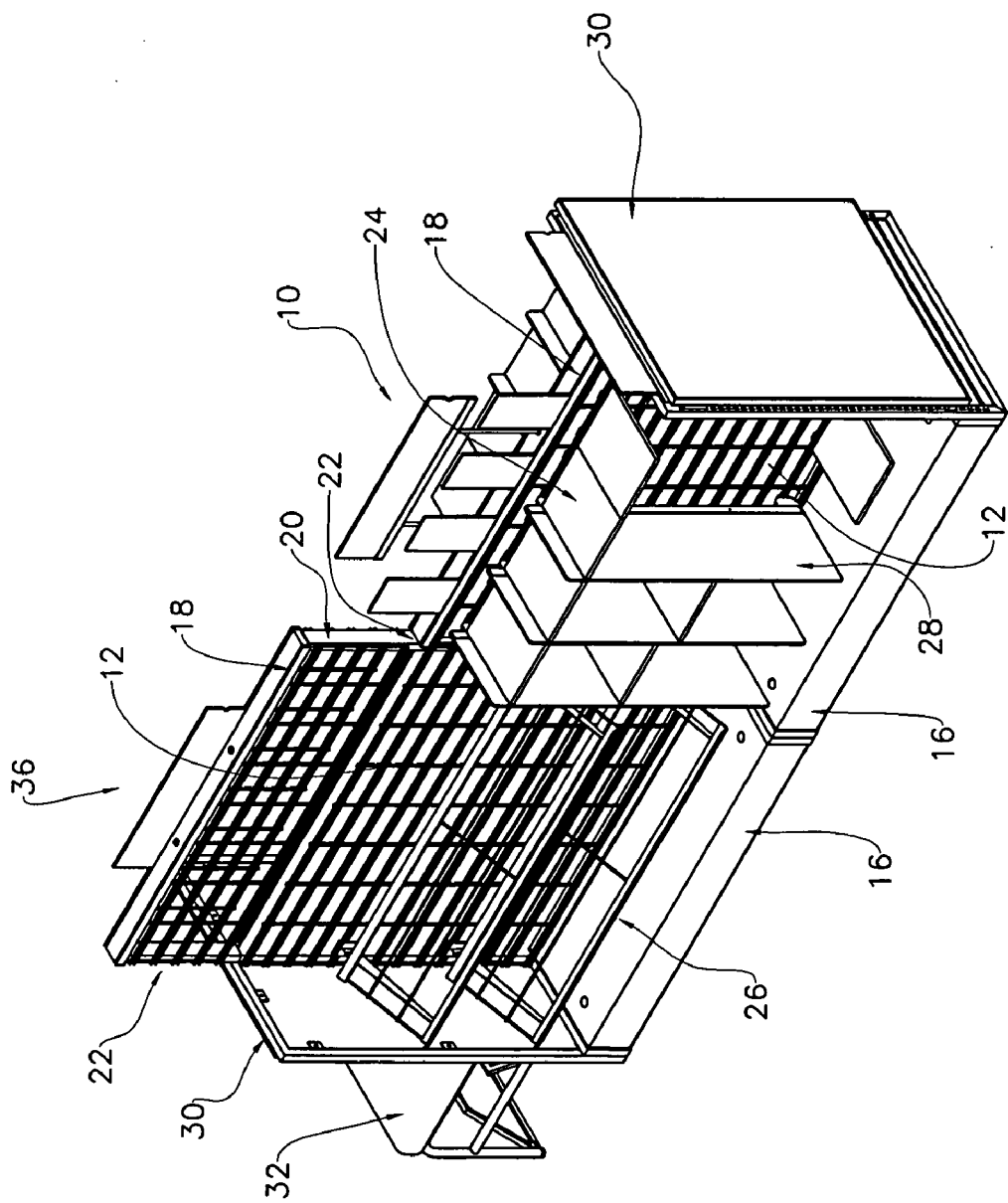

Figure 4

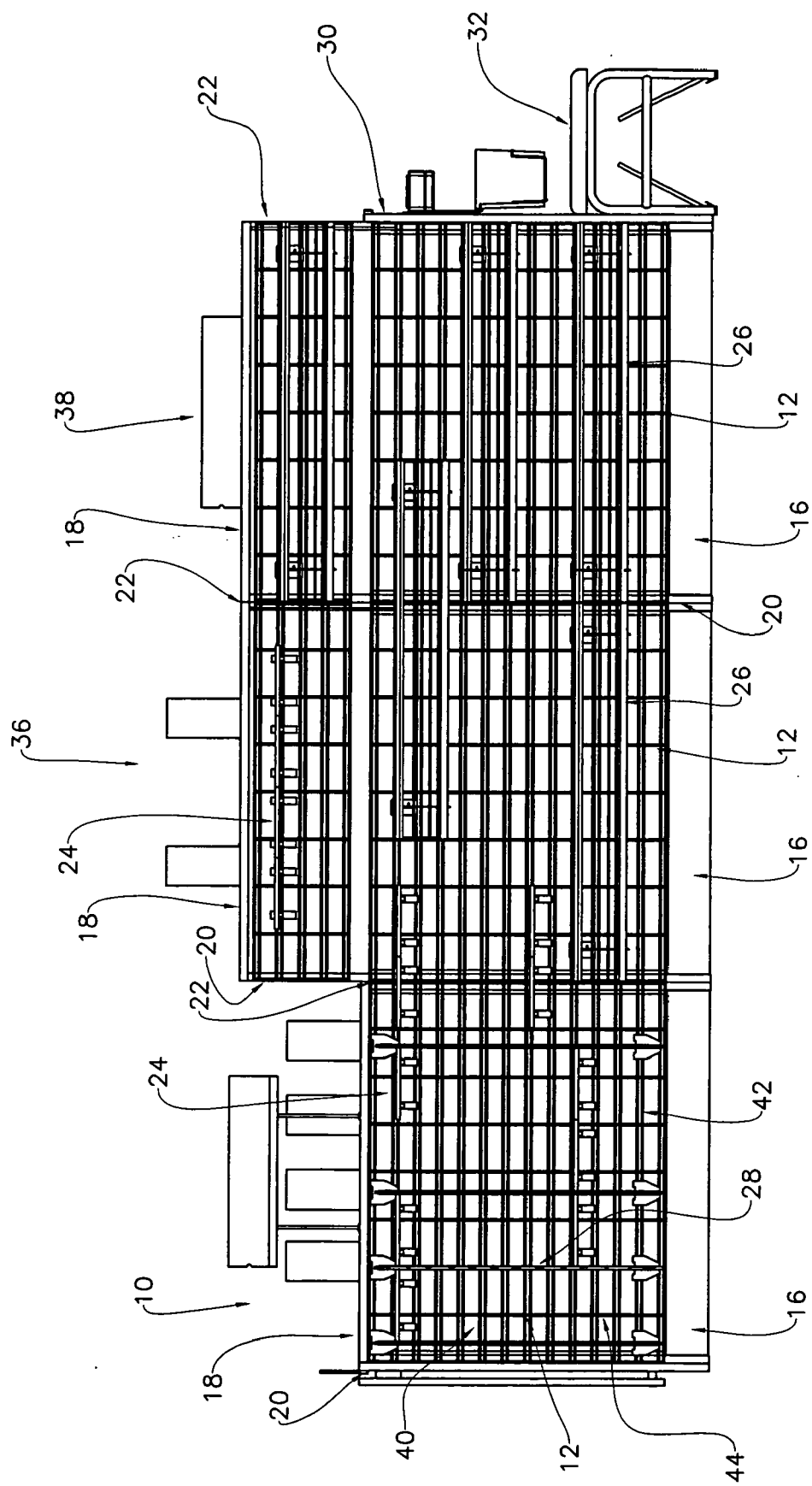

Figure 5

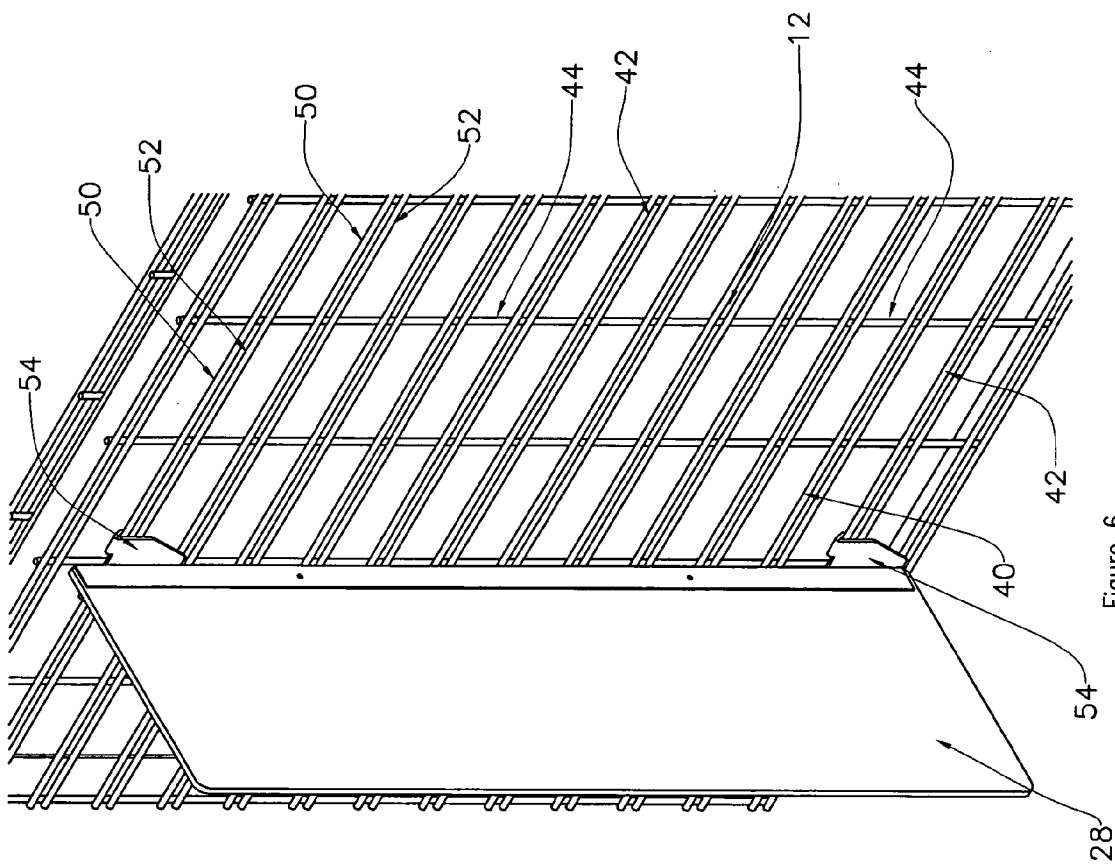
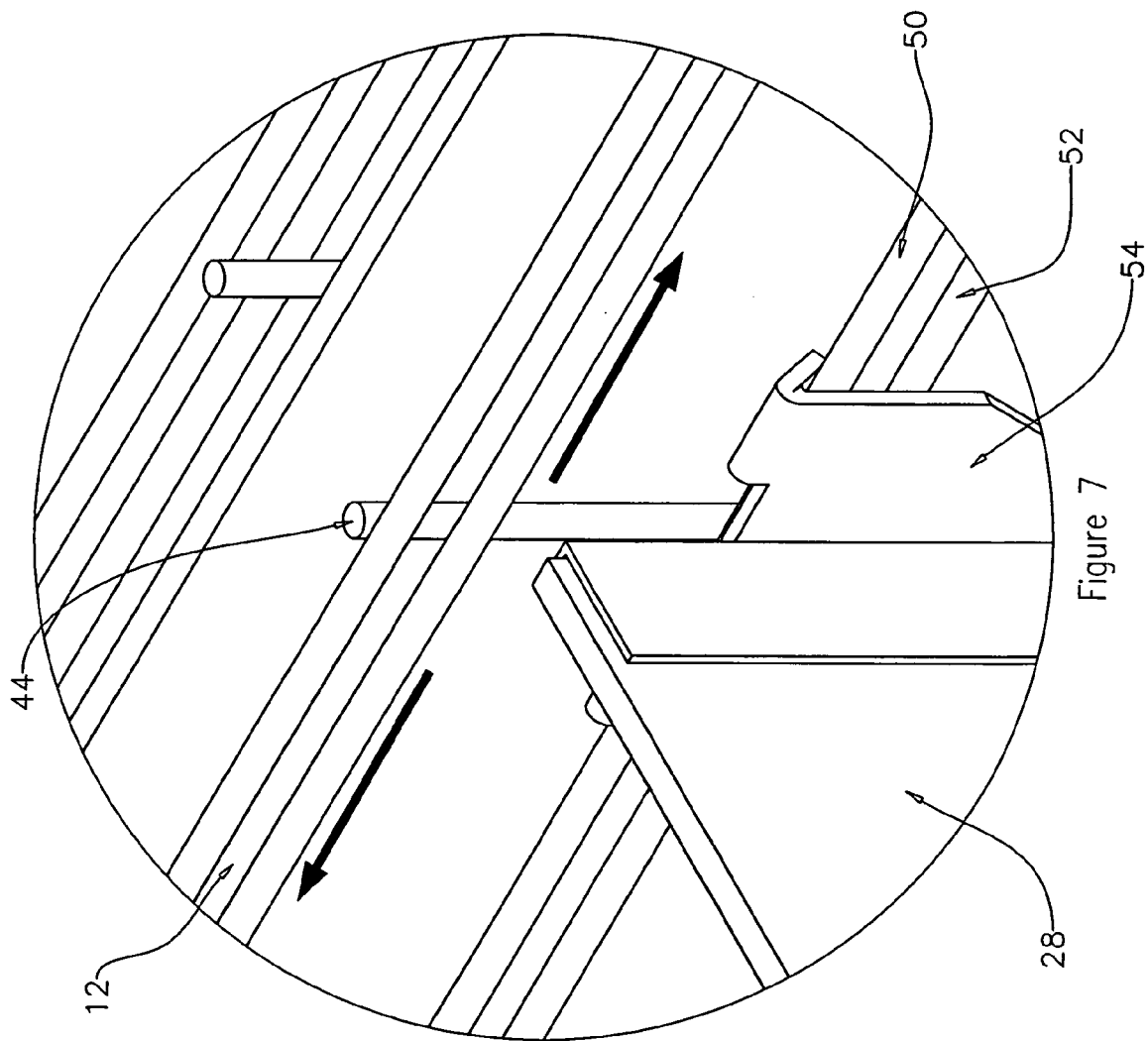

Figure 6



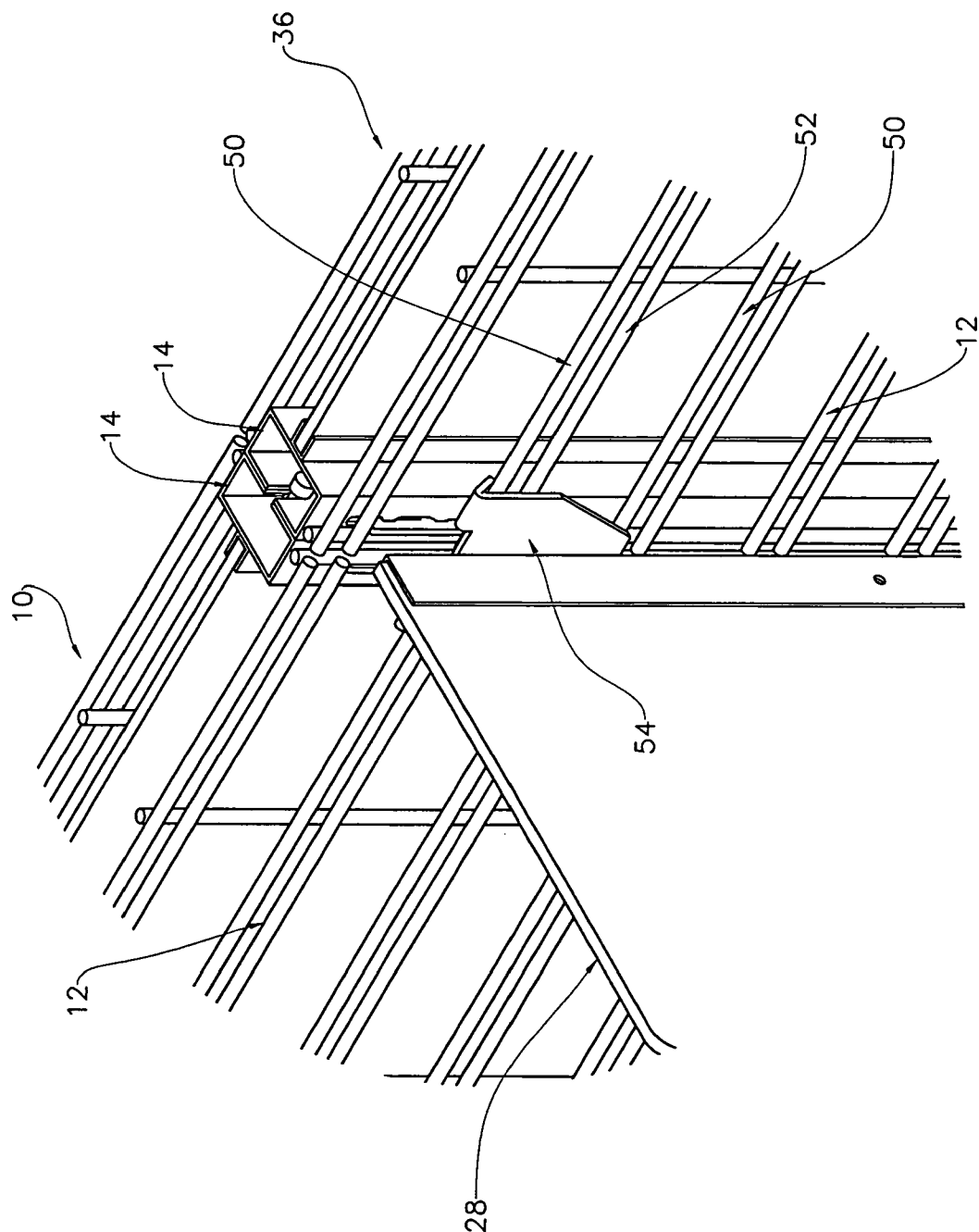

Figure 8

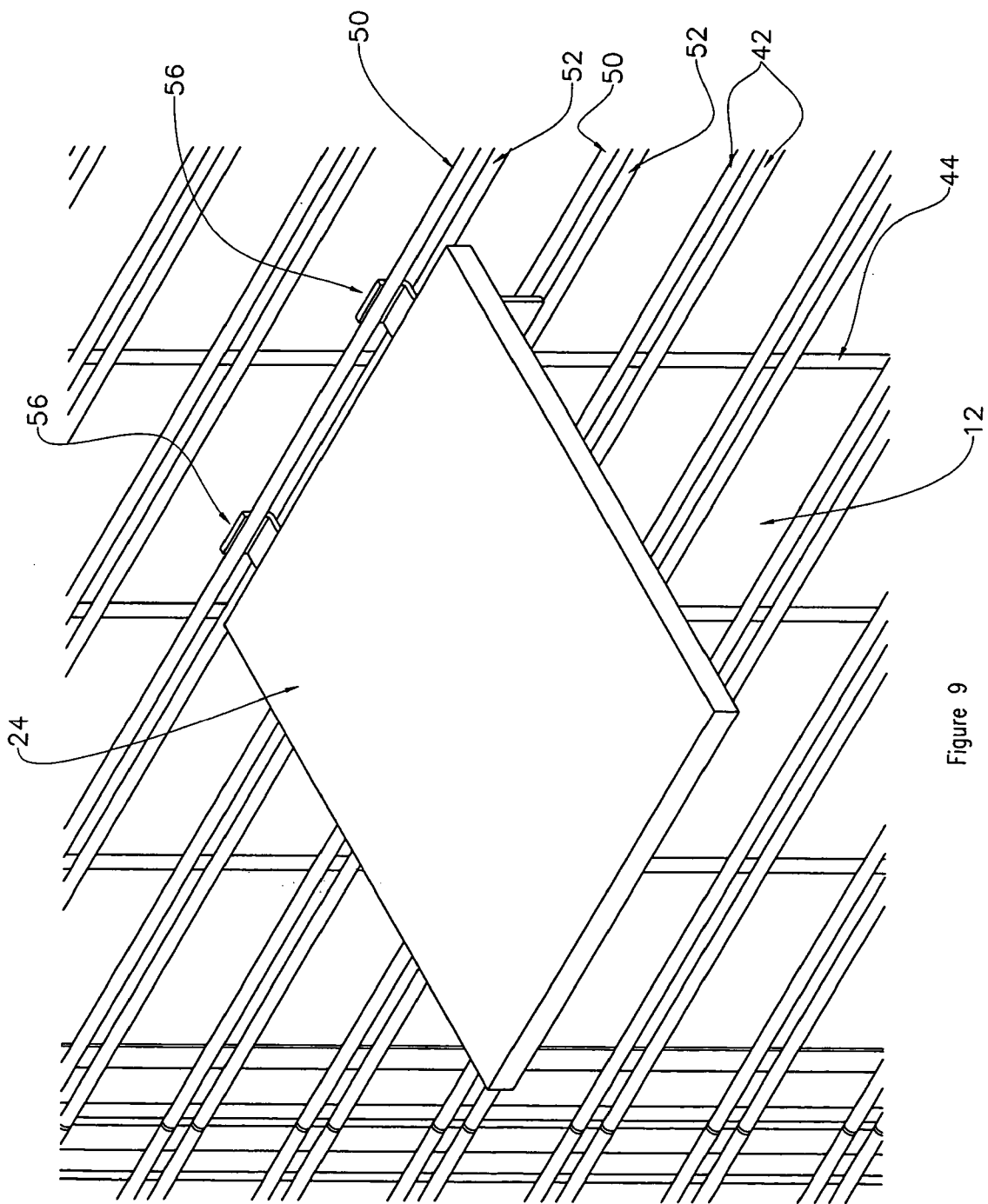

Figure 9

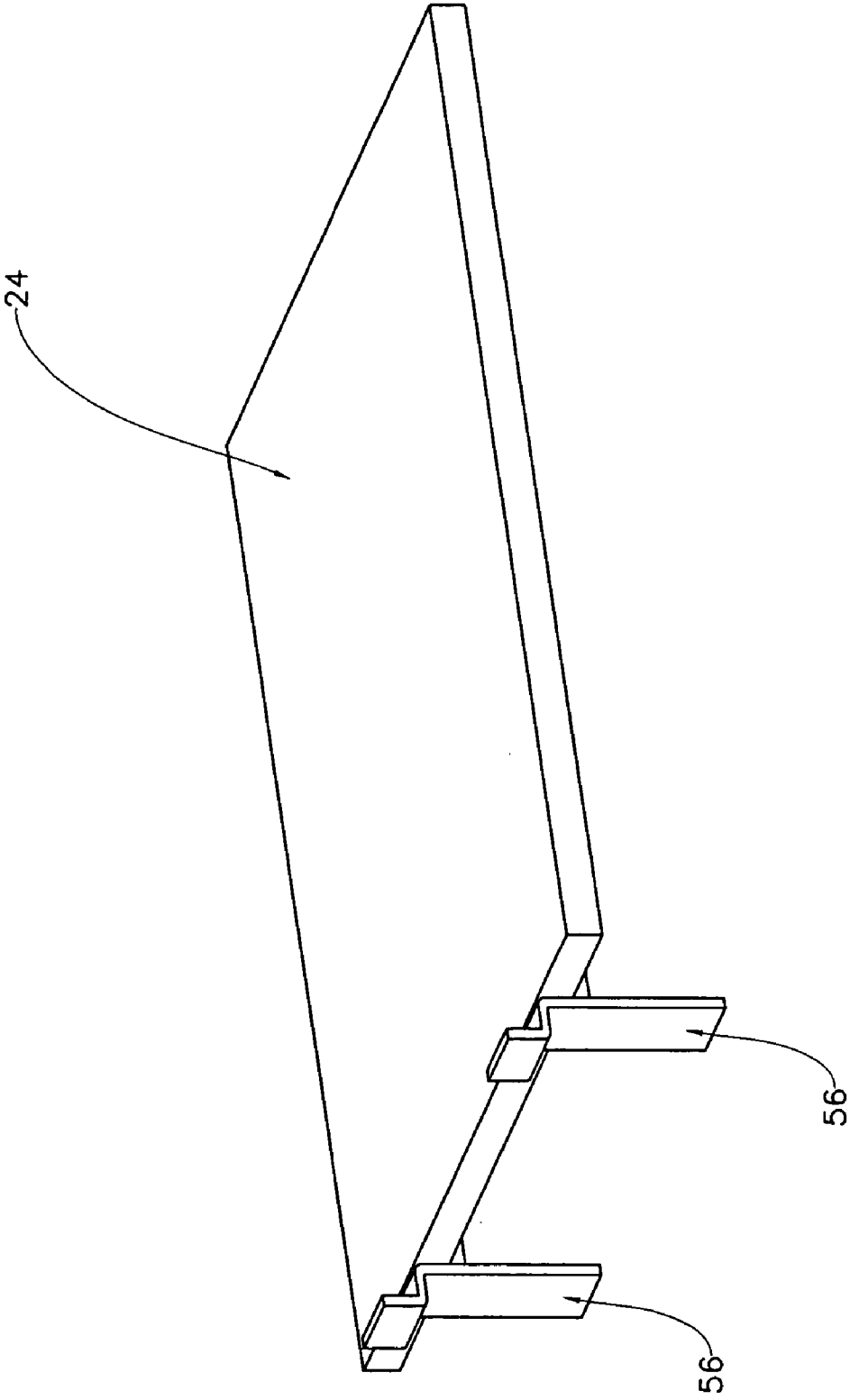

Figure 10

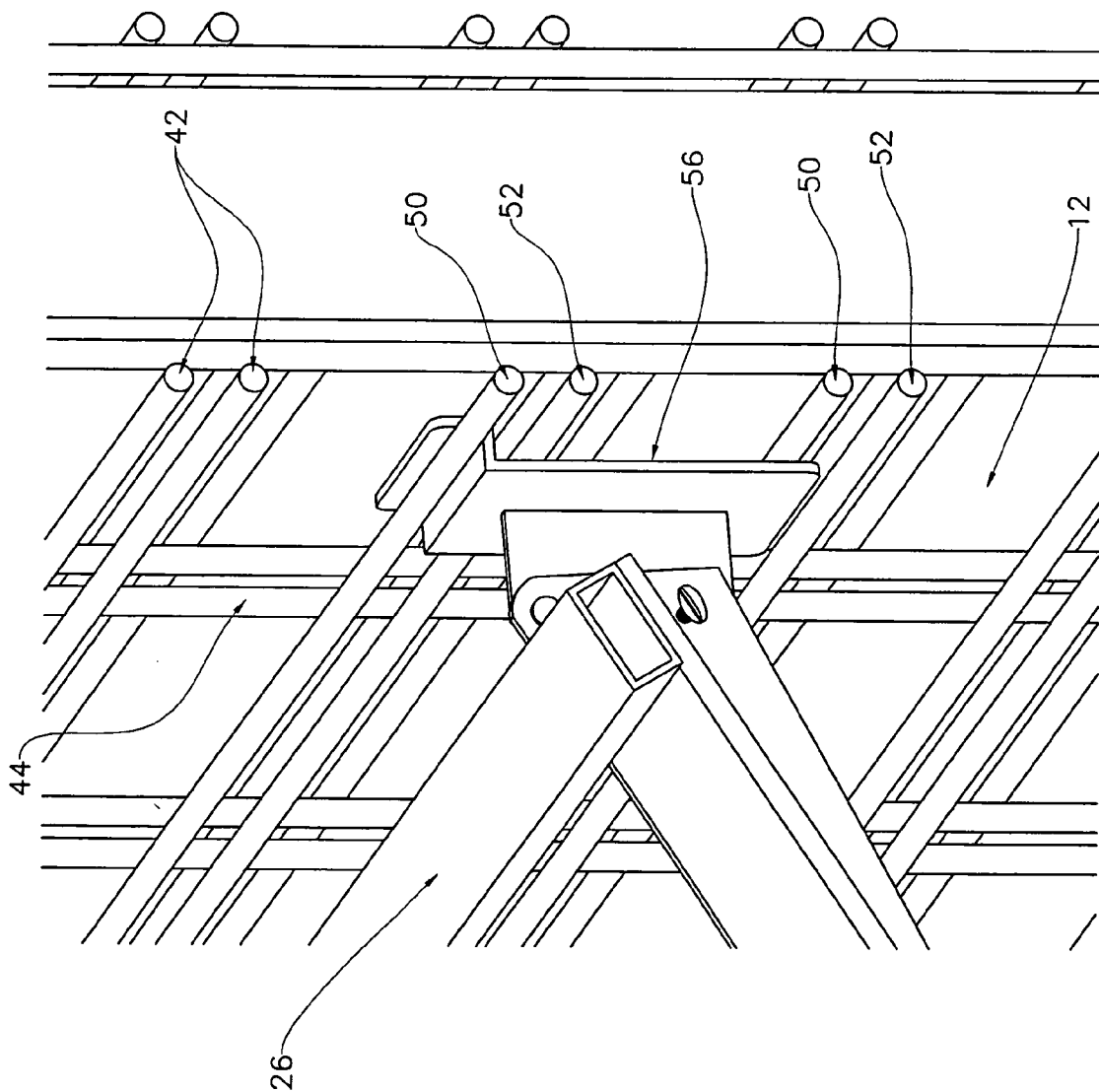

Figure 11

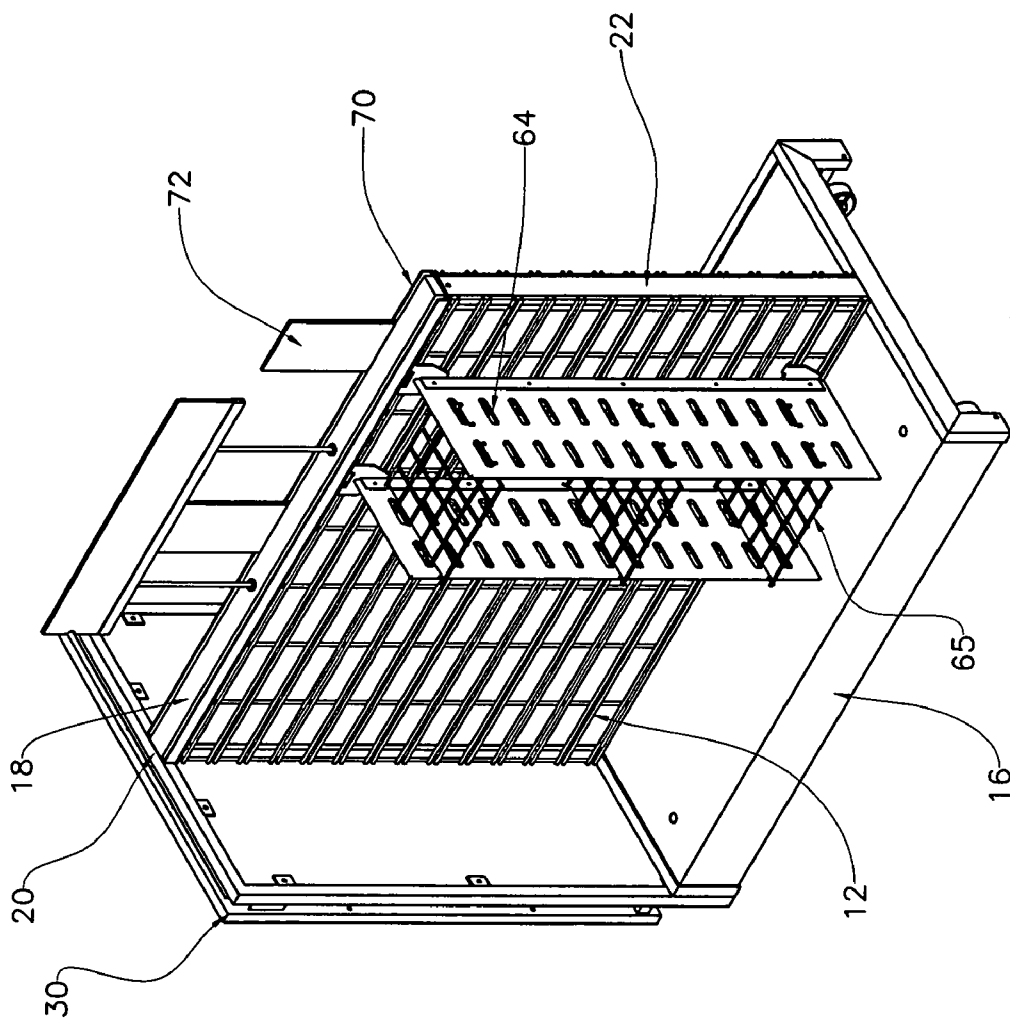

Figure 12

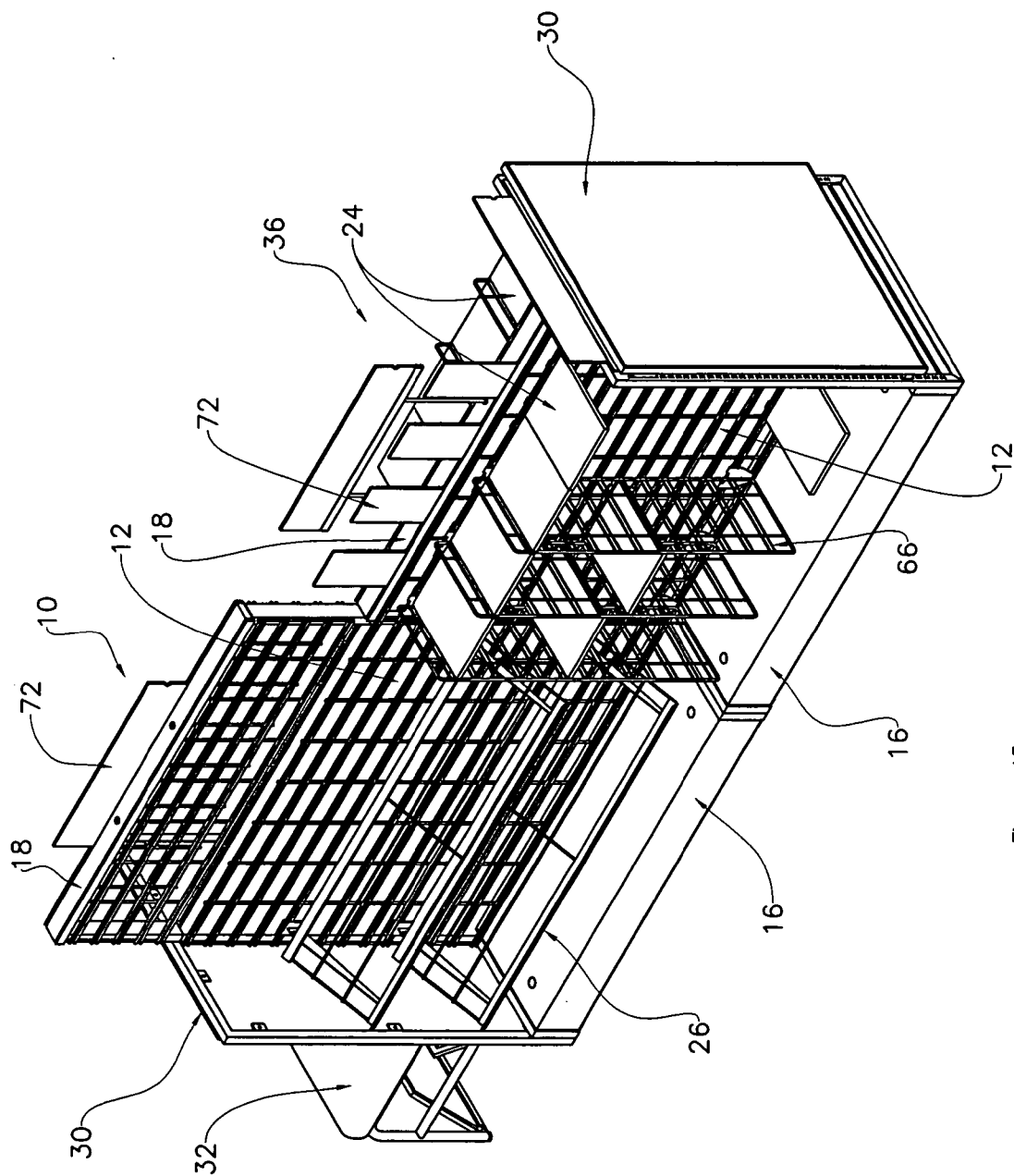

Figure 13

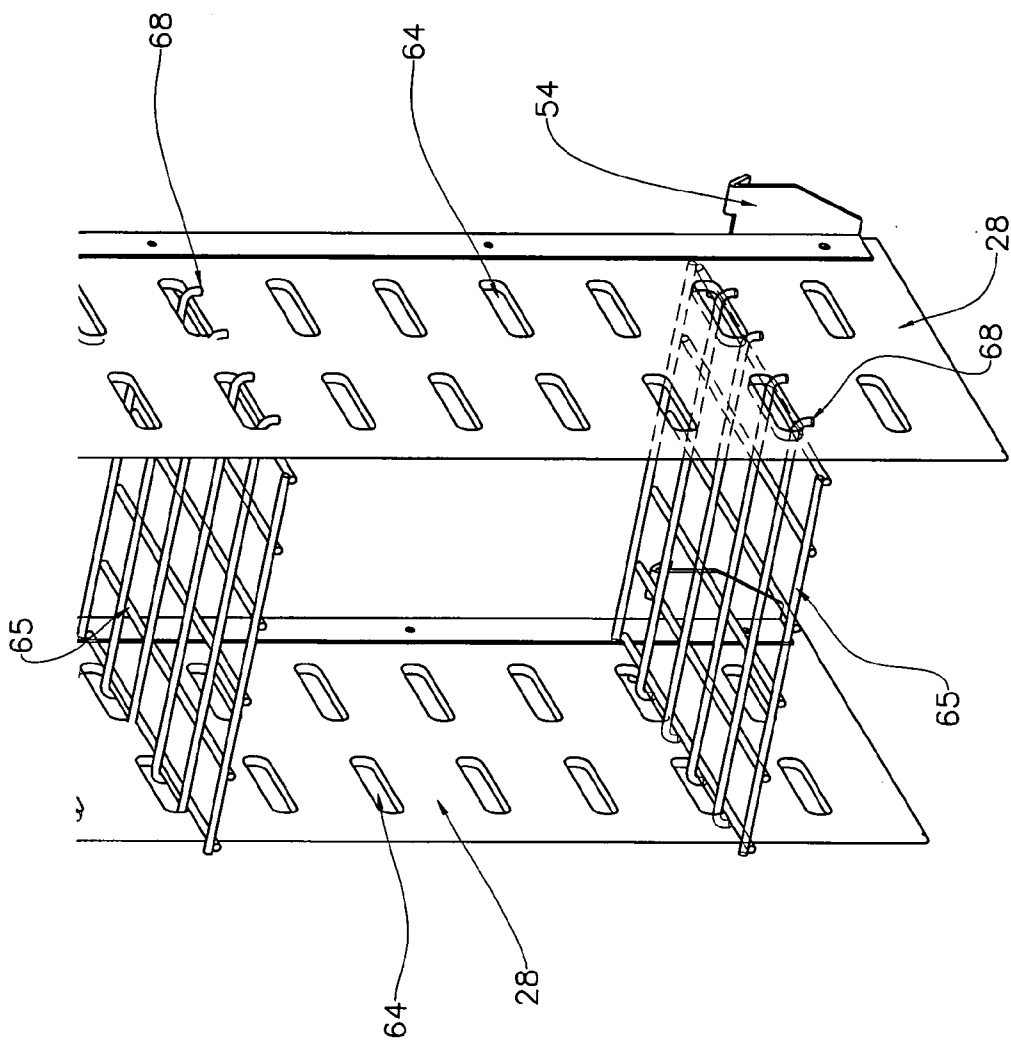

Figure 14

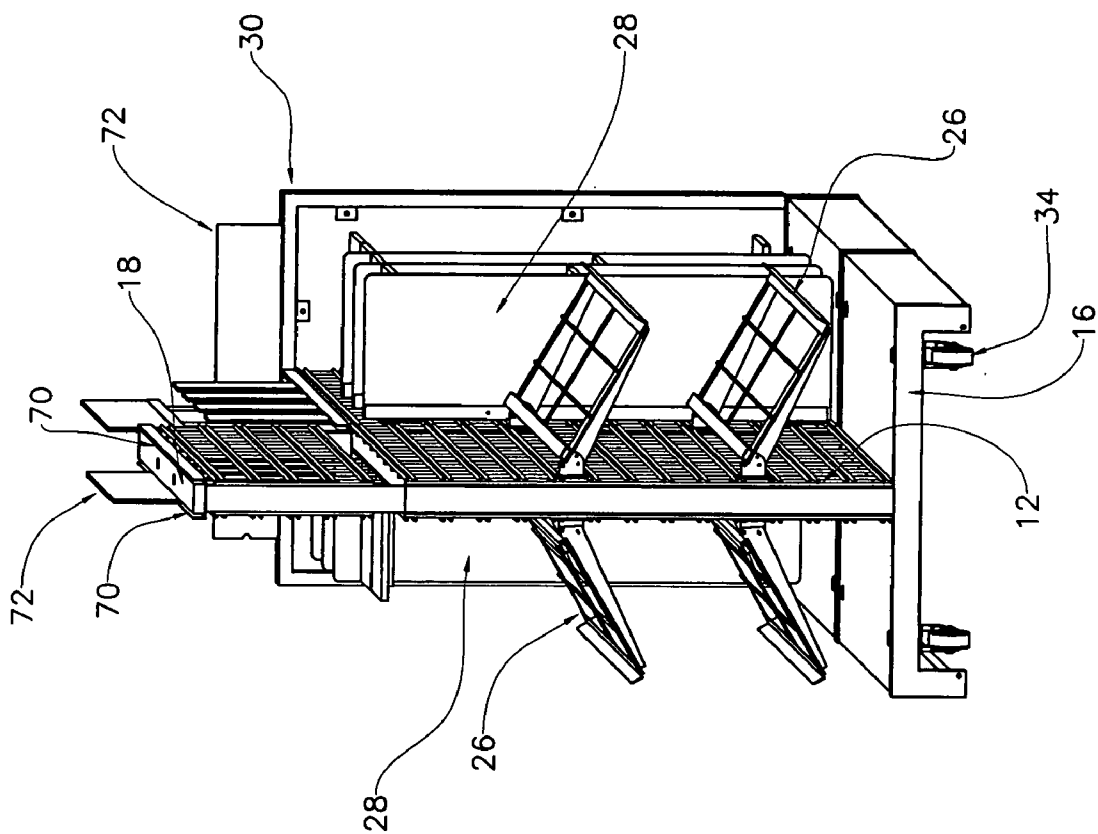

Figure 15

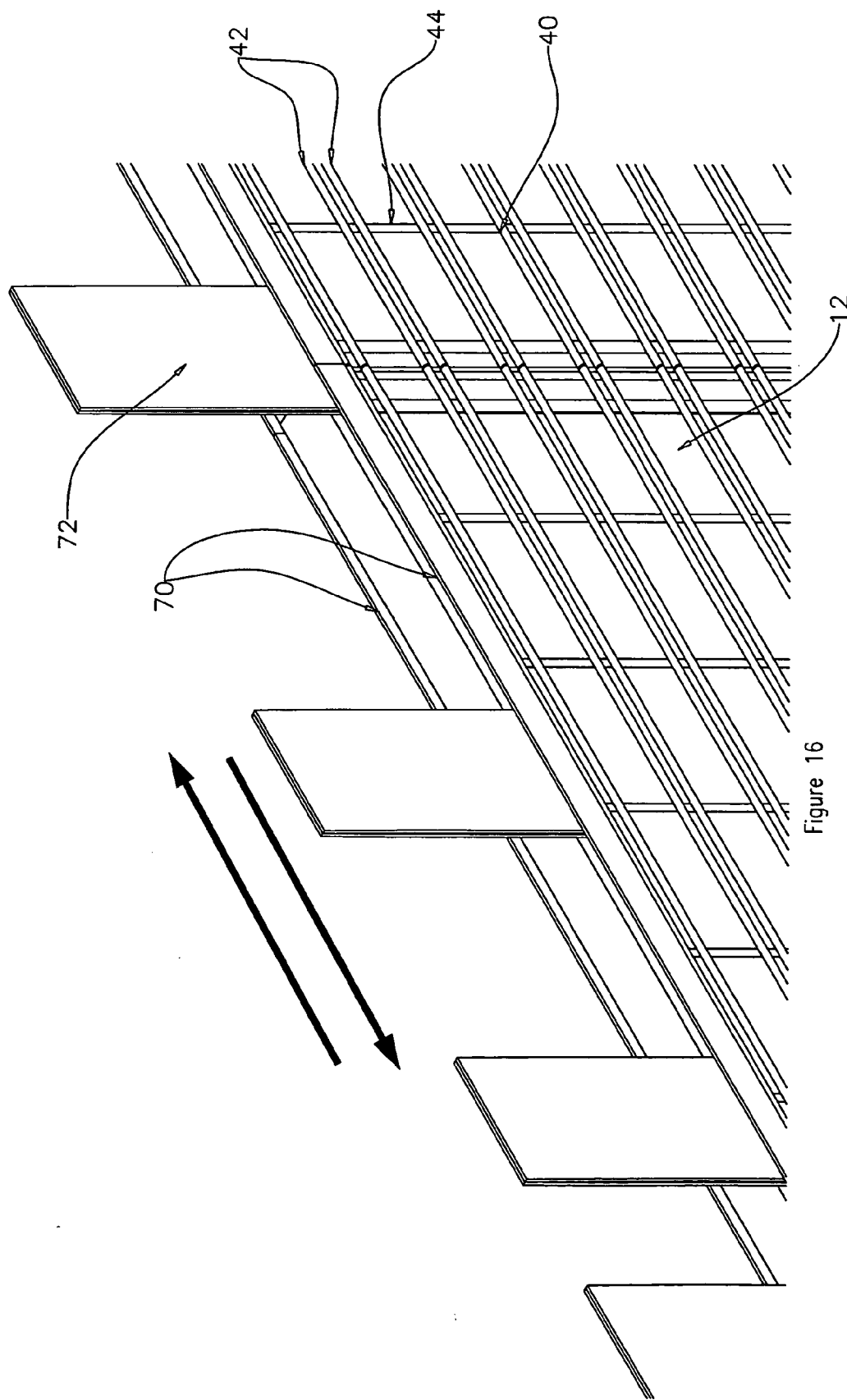

Figure 16

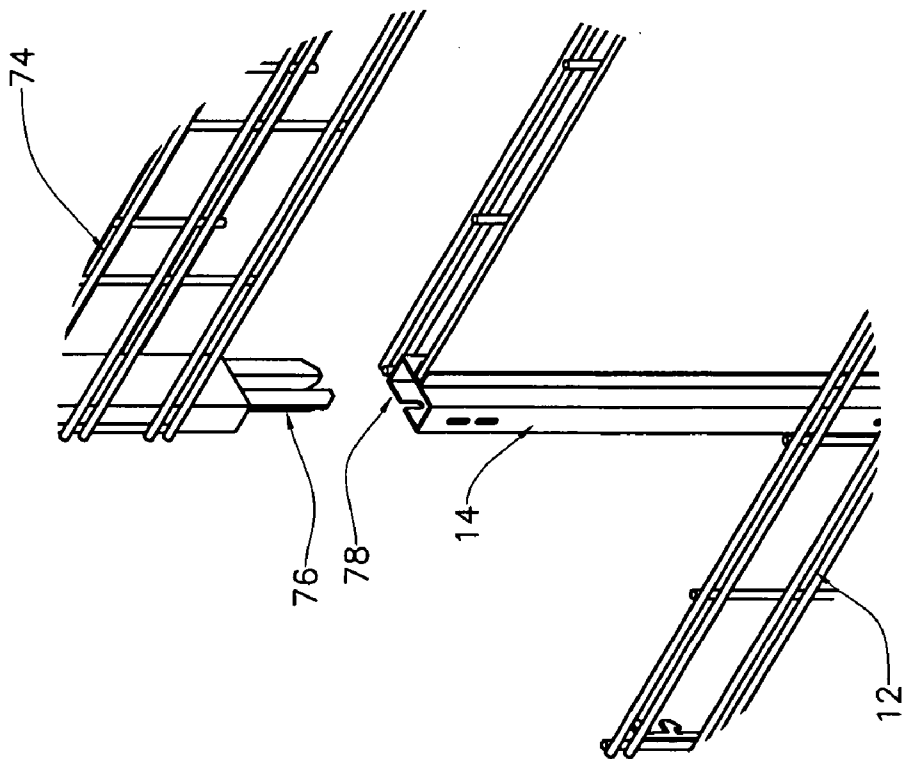

Figure 17

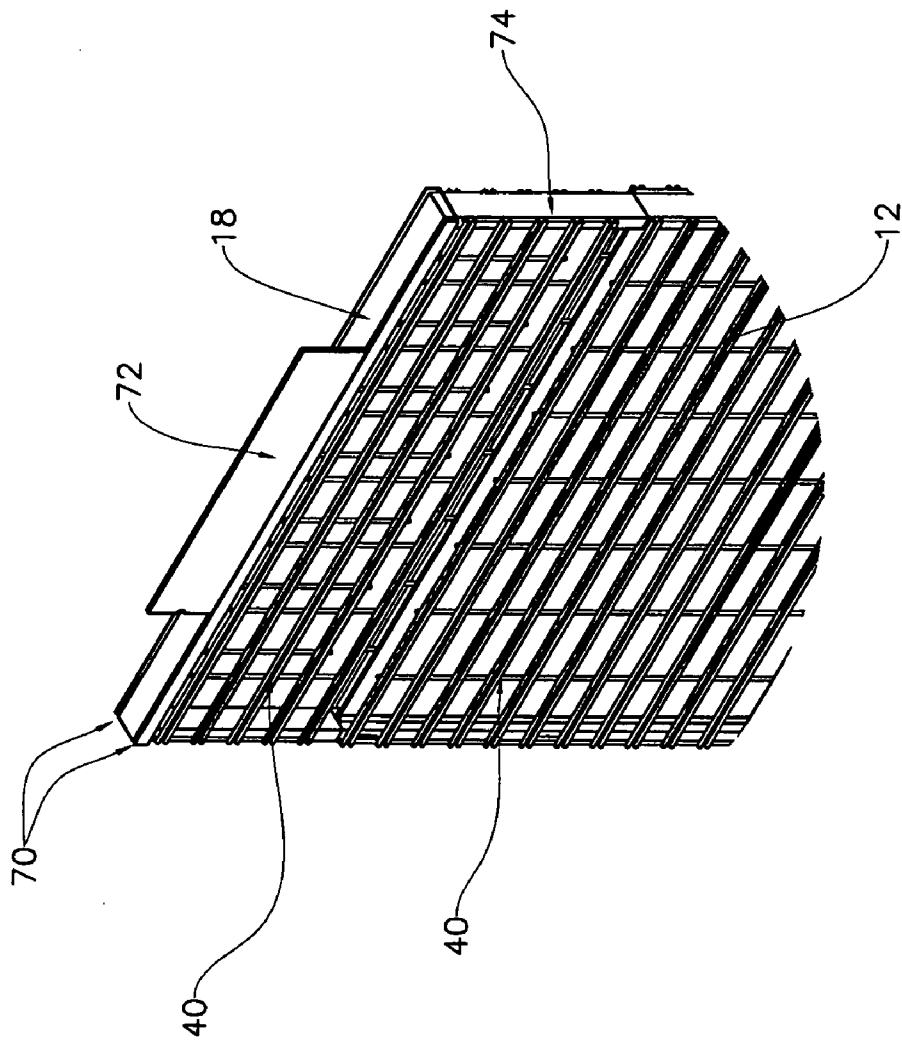

Figure 18

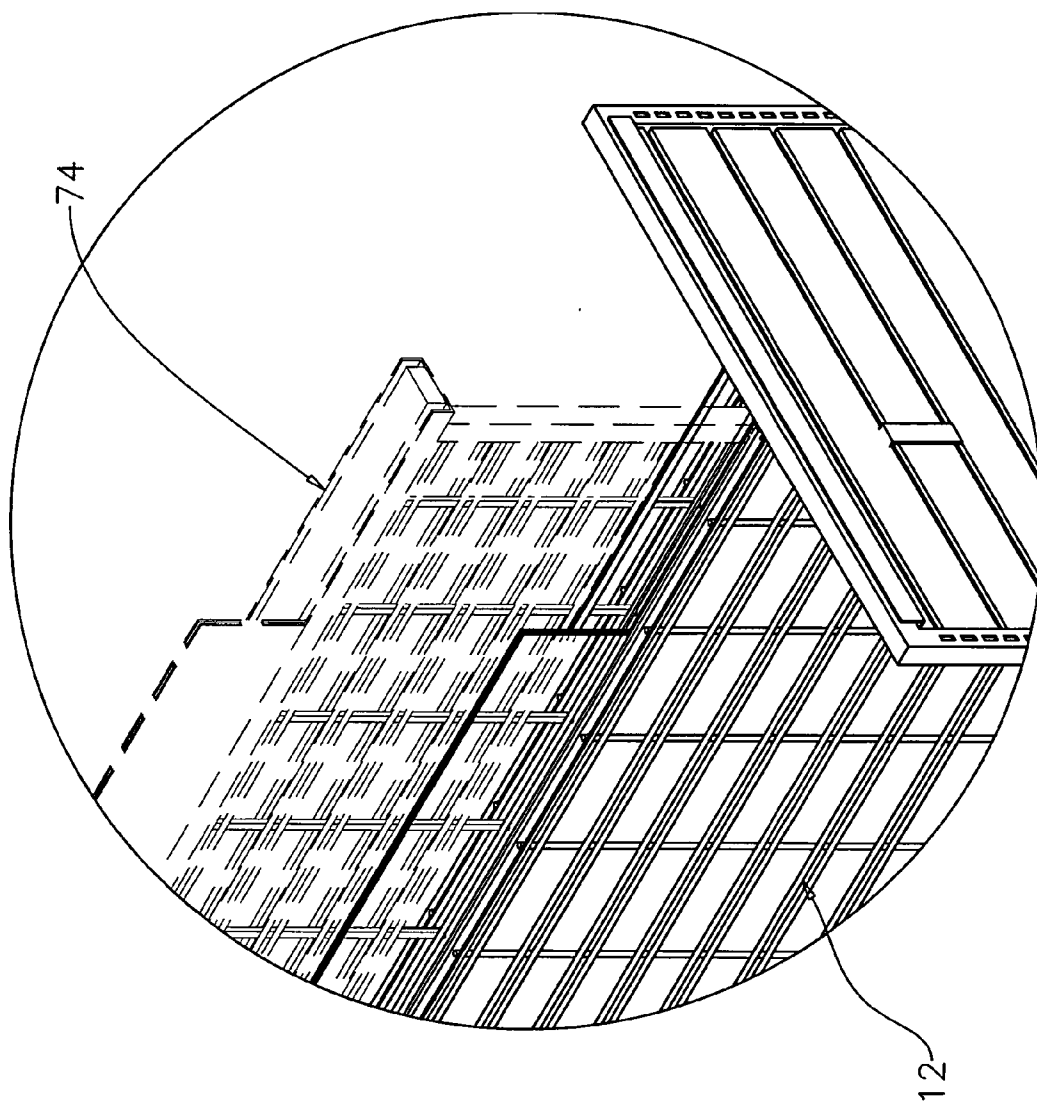

Figure 19

MERCHANDISE DISPLAY FIXTURE

BACKGROUND OF THE INVENTION

[0001] 1. Field of the Invention

[0002] The present invention relates to displaying merchandise and, more particularly, to displaying merchandise on an adjustable fixture and a method of arranging a variety of display patterns on the adjustable fixture.

[0003] 2. Description of Related Art

[0004] A variety of fixtures or racks are employed in the retail industry to display merchandise. The manner in which items are displayed for sale has been a factor in the successful marketing of products. The display fixtures should be aesthetically pleasing to the customer, provide an organized means of displaying the retail items, and provide the customer with a convenient way to access the retail items. Thus, a variety of shelving, brackets, and panels have been devised to accommodate these needs effectively, while at the same time cutting down on the amount of time and money spent in doing so.

[0005] Typically, the most common fixtures used employ a slat board or an open grid back panel. Slat boards are generally made of laminated composite board and include parallel slots arranged every few inches apart on the board. The slots are capable of receiving a mating end attached to a variety of display fixtures such as shelves. Open grid back panels generally include a wire grid pattern, wherein a variety of horizontal shelves or support rods may be hung from the wire grid. The wire grid is advantageous because of the versatility of the different types of display configurations that may be utilized. Additionally, wire grid pattern fixtures are generally less expensive to manufacture than slat board type displays.

[0006] An example of a merchandise display is disclosed in U.S. Pat. No. 6,564,952 to Suttles ('952 patent). As shown in **FIG. 1** of the '952 patent, the merchandise display includes two display racks arranged adjacent to one another. Each display rack generally includes a base and a vertical panel, wherein the vertical panel has horizontal slots for receiving items such as a shelf. Also, posts may be attached to either side of the display rack to provide support, and slots located within the posts may accommodate shelving. **FIG. 2** of the '952 patent illustrates wire grid having vertical wires and horizontal wires, wherein panels may attach thereto and hooks may be inserted within the horizontal slots to support a shelf. Similarly, additional display racks comprise a similar display pattern but have a lower array of open grid that is capable of receiving hooks and the like to support a shelf in the same manner as the slots described above.

[0007] Typical display fixtures, including the display fixture disclosed in the '952 patent, do not provide versatility in creating a variety of configurations for displaying merchandise. Display fixtures are generally limited in the types and sizes of merchandise that can be accommodated, and some fixtures are not capable of expansion to provide larger displays. Display fixtures generally take a significant amount of time to disassemble and reassemble into different configurations, and may require special training or tools.

[0008] Accordingly, a need exists for a merchandise display with an improved fixture for convenient configuration

into different display patterns while providing sufficient support for merchandise and being aesthetically pleasing to consumers. In addition, a need exists for a fixture that is easily expandable and transportable.

BRIEF SUMMARY OF THE INVENTION

[0009] The invention addresses the above needs and achieves other advantages by providing an improved display fixture for displaying merchandise. The display fixture is capable of being assembled in a variety of configurations to accommodate merchandise and other products. Further, the display fixture provides shelves and vertical partitions that may be attached to a back panel and are slidable along the back panel, and includes different embodiments of vertical partitions and shelves for creating various display configurations. Also, the display fixture is easily assembled and disassembled without the need for any special tools or training. In addition, the display fixture is expandable both laterally and vertically to create a display fixture assembly of various sizes.

[0010] In one embodiment, the display fixture includes a generally vertical back panel having opposed lateral edges and opposed top and bottom edges. The back panel defines at least one engageable member extending in a generally horizontal direction between the lateral edges. In addition, the display fixture includes at least one generally vertical partition comprising at least one cooperative engaging member removably attached to the engageable member of the back panel and extending substantially between the top and bottom edges of the back panel. The vertical partition further extends generally orthogonal from the back panel and generally orthogonal to the engageable member on the back panel. The vertical partition is advantageously removable and slidable in a lateral direction to define variable lateral positions on the back panel.

[0011] In one variation, the display fixture includes a back panel having a plurality of engageable members. Each engageable member may include two generally parallel wires or a gap defined between adjacent slat boards.

[0012] In addition, the display fixture may include at least one generally horizontal shelving member having a cooperative engaging member removably attached to the engageable member of the back panel to define a support surface. Thus, the horizontal shelving member is slidable in a lateral direction to define variable lateral positions on the back panel.

[0013] The display panel may also include a generally vertical back panel extension defining at least one engageable member therein, wherein the back panel extension is joined to the top edge of the back panel such that the back panel defines an increased number of engageable members. The vertical partition may have a first cooperative engaging member removably attached to the engageable member of the back panel extension and a second cooperative engaging member removably attached to the cooperative engageable member of the back panel, such that the vertical partition overlaps a bottom edge of the back panel extension and the top edge of the back panel. Alternatively, the back panel may further define an internal cavity having an opening in the top edge such that the back panel extension may be stored within the back panel in an inoperative position and raised out of the back panel and joined to the back panel in an operative position.

[0014] In another variation, the back panel defines a front surface and a back surface generally orthogonal to the lateral edges and to the top and bottom edges. The engageable member of the back panel is capable of receiving a vertical partition on the front surface and/or the back surface of the back panel. The display fixture may also have a support base having a plurality of wheels attached thereto, such that the back panel is transportable. Additionally, an end panel may be attached generally orthogonal to a lateral edge of the back panel, wherein the end panel includes at least one engageable member extending in a generally transverse direction to the engageable member defined in the back panel. Advantageously, the engageable member in the end panel is capable of receiving at least one generally horizontal shelving member.

[0015] The display fixture may further include a second back panel positioned adjacent to a lateral edge of the first back panel such that the first and second back panels are end-to-end. A generally horizontal shelving member may be removably attached to at least one engageable member in the back panel and the second back panel such that the horizontal shelving member overlaps adjacent lateral edges on the first and second back panels. In addition, the horizontal shelving member is slidable in a lateral direction to define variable lateral positions on the first and second back panels.

[0016] In another embodiment of the present invention, a display fixture includes a generally vertical back panel having opposed lateral edges, a top edge defining a generally horizontal surface, and a bottom edge opposite the top edge. The top edge defines at least one groove that extends in a generally horizontal direction between the opposed lateral edges of the back panel. Additionally, the display fixture includes at least one generally vertical display panel removably inserted within the groove of the top edge such that the display panel is laterally slidable within the groove to define variable lateral positions on the top edge.

[0017] The display fixture defining a groove therein may also include at least one generally vertical partition removably attached to the back panel such that at least one display panel is positioned laterally proximate to the vertical partition. Also, the top edge of the back panel may define a second groove that is substantially parallel to the first groove such that at least one display panel is removably inserted and laterally slidable within each groove.

[0018] In yet another embodiment of the present invention, the display fixture includes a generally vertical back panel having opposed lateral edges and opposed top and bottom edges, wherein the back panel defines at least one engageable member extending in a generally horizontal direction between the lateral edges. The display fixture further includes at least one generally vertical partition having at least one cooperative engaging member removably attached to the engageable member of the back panel, wherein the vertical partition further extends generally orthogonal from the back panel and generally orthogonal to the engageable member on the back panel. The vertical partition is slidable in a lateral direction to define variable lateral positions of the vertical partition, and also defines at least one engageable member in a lateral edge of the vertical partition. In addition, the display fixture includes at least one generally horizontal shelving member having opposed lateral edges and having at least one cooperative engaging

member on a lateral edge of the horizontal shelving member. The cooperative engaging member of the horizontal shelving member is inserted within the engageable member of the vertical partition such that the horizontal shelving member is supported by the vertical partition to provide a support surface.

[0019] The engageable member of the vertical partition may have an elliptical recess defined within the lateral edge of the vertical partition, or the engageable member may have two generally parallel and horizontal wires defined within the lateral edge of the vertical partition. Further, the vertical partition may extend substantially between the top edge and the bottom edge of the back panel. Moreover, the horizontal shelving member may further include at least one cooperative engaging member on opposed lateral edges of the horizontal shelving member such that the horizontal shelving member is removably attached to an engageable member of the vertical partition on each lateral edge of the horizontal shelving member to provide a support surface.

[0020] The present invention also includes a method for assembling a merchandise display fixture. The method includes the steps of providing a generally vertical back panel having opposed lateral edges and opposed top and bottom edges, wherein the back panel defines at least one engageable member extending in a generally horizontal direction between the lateral edges. The method further includes attaching at least one generally vertical partition to the back panel, wherein the vertical partition includes at least one cooperative engaging member removably attached to the engageable member of the back panel. The vertical partition is slidable in a lateral direction to define variable lateral positions of the vertical partition.

[0021] The display fixture of the present invention advantageously provides for increased versatility and variety in displaying merchandise. The display fixture is easily assembled and can be assembled in several different configurations for accommodating different types and sizes of merchandise. Similarly, the display fixture can be easily disassembled and reassembled in a different configuration, without the use of special tools or training. In addition, several display fixtures can be positioned adjacent to one another to expand the amount of merchandise that is displayed.

[0022] Many features enhance the flexibility of the display fixture. For example, vertical partitions may be attached and reattached to a back panel or slid along the back panel, and shelves may be positioned at any location, either adjacent or nonadjacent to the vertical partition. The shelves may independently attach to the back panel, attach directly to the vertical partitions, or attach to both the back panel and vertical partition. Also, different sizes of shelves may be attached to accommodate different sizes of merchandise. In addition, the back panel of the display fixture is expandable vertically to create taller displays. The display fixture advantageously includes easily adjustable display panels located on a top edge of the display fixture that permits the display panel to correspond to the variety of positions of the vertical partitions and horizontal shelves, wherein the display panel graphically illustrates the merchandise that is being displayed.

BRIEF DESCRIPTION OF THE SEVERAL
VIEWS OF THE DRAWING(S)

[0023] Having thus described the invention in general terms, reference will now be made to the accompanying drawings, which are not necessarily drawn to scale, and wherein:

[0024] FIG. 1 is a perspective view of a single display fixture in accordance with one embodiment of the present invention, illustrating vertical partitions and shelves removably attached to a back panel of the display fixture;

[0025] FIG. 2 is perspective view of another variation of the single display fixture shown in FIG. 1;

[0026] FIG. 3 is a perspective view of a display fixture assembly according to another embodiment of the present invention, illustrating two display fixtures having a variety of display configurations thereon;

[0027] FIG. 4 is another perspective view of the display fixture assembly shown in FIG. 3;

[0028] FIG. 5 is a front view of a display fixture assembly according to yet another embodiment of the present invention, illustrating three display fixtures having a variety of display configurations thereon;

[0029] FIG. 6 is a perspective detail view of a single vertical partition according to the present invention, illustrating the vertical partitions shown in FIGS. 1-5;

[0030] FIG. 7 is a perspective detail view of a vertical partition bracket according to the present invention, illustrating that the vertical partitions shown in FIGS. 1-5 are removably attached to the back panel of the display fixture;

[0031] FIG. 8 is another perspective detail view of the vertical partition bracket shown in FIG. 7, illustrating the bracket bridging two adjacent display fixtures;

[0032] FIG. 9 is a perspective detail view of a shelf used with the display fixtures shown in FIGS. 1-5, illustrating that the shelf is removably attached to the back panel of the display fixture;

[0033] FIG. 10 is another perspective detail view of the shelf shown in FIG. 9 according to one shelf embodiment, illustrating shelf brackets;

[0034] FIG. 11 is a perspective detail view of a shelf bracket according to an alternative shelf embodiment;

[0035] FIG. 12 is a perspective view of a display fixture according to another embodiment of the present invention, illustrating vertical partitions having recesses defined therein;

[0036] FIG. 13 is a perspective view of a display fixture according to yet another embodiment of the present invention, illustrating vertical partitions having wire grid defined therein;

[0037] FIG. 14 is a perspective detail view of a shelf according to the present invention, illustrating an alternative shelf embodiment having protrusions extending from the shelf that mate with the recesses of the vertical partitions shown in FIG. 12;

[0038] FIG. 15 is a perspective view of a display fixture according to another embodiment of the present invention, illustrating a display panel inserted within a groove;

[0039] FIG. 16 is a perspective detail view of display panels according to the present invention, illustrating two grooves for accommodating display panels on the back panel of the display fixture;

[0040] FIG. 17 is a perspective detail view of a vertical extension according to another embodiment of the present invention, illustrating that the vertical extension may be removably connected to the back panel;

[0041] FIG. 18 is another perspective detail view of the vertical extension shown in FIG. 17, illustrating the vertical extension connected to the back panel; and

[0042] FIG. 19 is a perspective detail view of a vertical extension according to yet another embodiment of the present invention, illustrating that the vertical extension may be raised in and out of a cavity having an opening defined in a top edge of the back panel.

DETAILED DESCRIPTION OF THE
INVENTION

[0043] The present invention now will be described more fully hereinafter with reference to the accompanying drawings, in which some, but not all embodiments of the invention are shown. Indeed, this invention may be embodied in many different forms and should not be construed as limited to the embodiments set forth herein; rather, these embodiments are provided so that this disclosure will satisfy applicable legal requirements. Like numbers refer to like elements throughout.

[0044] Referring now to the drawings and, in particular to FIG. 1, there is shown a display fixture 10. The term "display fixture" is not meant to be limiting, and it is understood that the term display fixture could be any arrangement used to display, store, shelve, or organize merchandise. Thus, the display fixture 10 could not only be used to display merchandise on the floor of a department store, but could also be used for storage generally or simply to provide a variety of ways to organize merchandise. In addition, the term "merchandise" is not meant to be limiting and could be any product or good, and thus the display fixture should not be limited for use only in a commercial setting for displaying merchandise, as the display fixture could be used in any commercial setting, as well as for personal storage or organization.

[0045] It is also understood that the term "engageable member" could be any number of wire grid patterns, slat boards, recesses, wire mesh, and the like. Thus, the term engageable member is not meant to be limiting, and is used generically. In addition, the term "engaging member" is not meant to be limiting, and could include hooks, brackets, protrusions, flanges, or the like. Therefore, the term engaging member is not meant to be limiting and is referred to as any hook, bracket, protrusion, flange, or the like that may be removably attached to the engageable member defined above.

[0046] As shown in FIG. 1, there is a display fixture 10 for displaying merchandise. The display panel 10 is capable of supporting shelves, vertical partitions, and the like on a grid, slat board, or similar panel. The display fixture 10 may advantageously be assembled and disassembled by either removing or by simply sliding the shelves and vertical partitions to a desired location on the back panel. The

display fixture 10 may be assembled in many different configurations depending on the type of merchandise to be displayed. In addition, multiple display fixtures 10 may be incorporated for larger displays.

[0047] The display fixture shown in FIGS. 1-2 includes a back panel 12, or center panel as known to those skilled in the art. The back panel 12 includes support ends 14, a base 16, a top edge 18, and two lateral edges 20, 22. The back panel 12 is capable of supporting shelves 24, 26 as well as vertical partitions 28, as will be discussed in detail below. Preferably, the display fixture 10 also includes an end panel 30 that is generally orthogonal and adjacent to the back panel 12 of the display fixture. The end panel 30 is also capable of supporting shelves 24, 26. The display fixture 10 may alternatively include an end panel 30 having a shoe bench 32 located proximate thereto. As FIG. 1 illustrates, the display fixture 10 may be mounted on wheels 34 to allow the display fixture to be transportable. However, it is understood that the display fixture 10 could have no wheels, or alternatively, adjustable levelers could be mounted to the base 16.

[0048] As FIGS. 3-5 illustrate, there may be two or three display fixtures 10, 36, 38 arranged end-to-end and adjacent to each other to form a display fixture assembly. Thus, there could be one display fixture 10, or there could be any number of display fixtures arranged end-to-end by aligning the lateral edges 20, 22 of the display fixtures 10, 36, 38 adjacent to one another. Additionally, two display fixtures 10, 36 could also be positioned with the back panels 12 of each display fixture adjacent to each other. This arrangement provides a display fixture assembly that is self supporting, but also provides an assembly that could advantageously be used as a display in a commercial environment where maximum use of space for displaying merchandise is desired.

[0049] The back panel 12 shown in FIGS. 1-5 includes a wire grid 40 having horizontal wires 42 and vertical wires 44 arranged in a perpendicular grid on the back panel 12. The wire grid 40 extends vertically between the top edge 18 and base 16 of the back panel 12, and horizontally between the lateral edges 20, 22 of the back panel. There are generally pairs of horizontal wires 42 spaced equidistantly and parallel between the top edge 18 and base 16 of the back panel 12, while there is one vertical wire 44 equally spaced between lateral edges 20, 22 of the back panel. The horizontal wires 42 and vertical wires 44 extend substantially perpendicular to one another. The horizontal wires 42 and vertical wires 44 generally provide support to the back panel 12, and shelves 24, 26 and vertical partitions 28 may attach to the horizontal wires and slide to variable lateral positions, as will be described in more detail below.

[0050] Although the display fixtures 10, 36, 38 in FIGS. 1-5 illustrate a back panel 12 having wire grid 40, it is understood that other patterns could be used. For example, the end panel 30 includes longitudinal slots 48 defined therein, wherein the slots are capable of supporting a shelf 24, 26, as shown in FIGS. 2-3. Similarly, the back panel 12 may include longitudinal slots 48 or slat board, as known in the art, where the slat board also defines longitudinal slots extending parallel between the lateral edges 20, 22 of the back panel and between the top edge 18 and base 16 of the back panel. Also, the end panel 30 may include slat board,

or may alternatively include wire grid 40 as described above for the back panel 12. The wire grid 40 may include different patterns of horizontal 42 and vertical 44 wires, as well as different sizes of wire gauges, but preferably provides a wire grid capable of providing support for attachment of shelves 24, 26, vertical partitions 28, and the like.

[0051] FIG. 6 illustrates that the vertical partition 28 extends vertically and attaches to the back panel 12. The vertical partition 28 attaches perpendicularly to the back panel 12 such that the lateral sides of the vertical partition extend outwardly from the back panel, although it is understood that the vertical partition could be non-orthogonal to accommodate different sizes and shapes of merchandise. The vertical partition 28 extends substantially from the top edge 18 to the base 16 of the back panel 12, although it is understood that the vertical partition could be any number of different lengths. For example, the vertical partition 28 could extend at least between two adjacent upper and lower wires 50, 52 when wire grid 40 is used.

[0052] The vertical partition 28 extends outwardly from the back panel 12 so as to create a divider or barrier. Thus, the vertical partition 28 could be used to separate columns of boxes without the use of shelves 24, 26. Alternatively, the vertical partitions 28 could be used in combination with shelves 24, 26, as illustrated in FIGS. 1-5. It is also understood that the vertical partitions 28 could be used in combination with shelves 24, 26, and that additional vertical partitions or shelves could be freely attached to the back panel 12 such that the vertical partition and shelves are not adjacent to one another. The vertical partition 28 must define lateral edges that are of sufficient surface area to provide a barrier to merchandise or other similar products desired to be separated vertically.

[0053] Brackets 54 attached to opposite ends of the vertical partition 28 allow the vertical partition to attach to the wire grid 40. FIG. 7 illustrates that the bracket 54 has two angled ends that are inserted above an upper wire 50 such that the two angled ends rest on the upper wire. The angled ends of the bracket 54 extend on either side of a vertical wire 44. Also, the angled ends of the bracket 54 generally rest on the upper wire 50, and the bottom portion of the bracket 54 extends downwardly and rests adjacent to a second upper wire 50 to secure the bracket to the wire grid 40. The second upper wire 50 is preferably an adjacent horizontal wire 42. The bracket 54 located on the opposite end of the vertical partition 28 would preferably attach to the wire grid 40 in the same manner, as shown in FIG. 6. Thus, the vertical partition 28 may be removed and reattached at different positions on the back panel 12, or the vertical partitions may be slid to different lateral positions on the back panel.

[0054] The bracket 54 on the vertical partition is shown in FIG. 7 as spanning a vertical wire 44, such that sliding of the vertical partition would be limited to the space between the angled ends of the bracket. However, it is appreciated that the angled ends of the bracket 54 could attach to the back panel 12 such that the angled ends do not span a vertical wire 44, and instead attach between adjacent vertical wires, which allow the vertical partition to slide between adjacent vertical wires. In addition, it is also understood that alternative wire grid 40 patterns could be used having no vertical wires 44, which allow the vertical partition to slide freely to various lateral positions between the lateral edges 20, 22.

[0055] FIG. 8 shows that the bracket 54 is capable of attaching to two adjacent display fixtures 10, 36. One angled end of the bracket 54 extends above an upper wire 50 on a first display fixture 10, while the other angled end extends above an upper wire 50 on the adjacent display fixture 36. The bottom portion of the bracket 54 extends downwardly and rests on an adjacent upper wire 50 on each of the adjacent display fixtures 10, 36. Thus, the bracket 54 is capable of being positioned on the back panel 12 at many different locations, as well as spanning adjacent display fixtures 10, 36.

[0056] Although FIGS. 6-8 illustrate the bracket 54 as having two angled ends and a bottom portion, the bracket should not be limited to such a bracket. For example, the bracket 54 could have one continuous angled end, as opposed to two angled ends, resting on the upper wire 50. Additionally, although the bottom portion of the bracket 54 is shown as resting on the upper wire 50 of an adjacent horizontal wire 42, the bottom portion could extend further, and even the entire length of the vertical partition 28. It is also understood that the bracket 54 could attach to the wire grid 40 such that the angled ends of the bracket 54 could be inserted between the upper 50 and lower 52 wires such that the two angled ends rest on the lower wire. The angled ends of the bracket 54 would generally provide a pinching pressure between the upper 50 and lower 52 wires to secure the bracket to the wire grid 40. It is further understood that alternative brackets 54 could be used with different wire grid 40 patterns. Thus, the bracket 54 is not limited to the angled ends as described above, as the bracket could be adapted to fit within various wire grids 40 or other similar designs capable of receiving a bracket, while also being attachable at various lateral positions on the back panel 12.

[0057] The vertical partition 28 is thus capable of being easily assembled and disassembled from the back panel 12. As such, no special training or tools are required to create various display configurations. The vertical partitions 28 may be completely removed from the back panel 12 and then moved to a different location on the back panel. Alternatively, the vertical partition could be slid to different lateral positions on the back panel as described above, which reduces downtime and increases versatility of displaying various sizes and types of merchandise.

[0058] The wire grid 40 defined within the back panel 12 is capable of supporting a shelf 24, where a bracket 56 attached to the shelf mounts within the wire grid. FIGS. 9-10 illustrate that the shelf 24 comprises opposed planar surfaces where one of the planar surfaces on the shelf serves as a support surface when the bracket 56 is engaged within the wire grid 40, longitudinal slots 48, or slots defined by slat board. Although the shelf 24 is shown as being substantially planar and horizontal, it is understood that the shelf may be non-horizontal and non-planar to accommodate various sizes and shapes of merchandise to be displayed.

[0059] The wire grid 40, longitudinal slots 48, and slat board advantageously provide the shelf 24 with a variety of attachment locations on the back panel 12. Therefore, the shelf 24 is removably attached to the back panel 12, and may be easily removed and reattached at various locations on the back panel. Similarly, the shelf 24 may slide laterally on the back panel 12 to position the shelf at various lateral positions.

[0060] Additionally, when two display fixtures 10, 36 are arranged in series, a shelf 24 could extend from one display fixture 10 to the adjacent display fixture 36, such that the horizontal shelf could be placed in any position in the horizontal direction along a series of display fixtures. Also, the wire grid 40 may be defined on both sides of one back panel 12 so that the shelf 24 may attach on either side of the back panel or on both sides simultaneously, as shown in FIGS. 1-4. Preferably, the shelf 24 is capable of supporting merchandise, such as a shoe box having shoes therein. It is understood that the shelf 24 could also be used to support other articles or products of various sizes, shapes, and weight. Therefore, the shelf 24 must provide a planar surface having a sufficient surface area and stiffness to support the product or item desired to be supported.

[0061] The present invention also includes other variations of the shelf 24. A longer shelf 26 could be used as shown in FIGS. 3-5. Thus, the longer shelf 26 could extend the entire width between the lateral edges 20, 22 of the back panel 12, or the longer shelf could extend a distance somewhere between the length of the shelf 24 and the entire width between the lateral edges of the back panel. Thus, different sized shelves are interchangeable to accommodate different merchandise or products. Similarly, an array of different sizes of shelves 24, 26 could be assembled on one back panel 12 to form an array of different merchandise or products. FIGS. 3-5 also illustrate that the shelf 26 may extend at an angle downwardly from its location of attachment to the back panel 12. Preferably a lip would extend along the edge of the shelf 26 not attached to the back panel 12 to prevent articles from sliding off of the shelf. It is understood that the longer shelf 26 may also be substantially horizontal, and that the shelf 24 may alternatively extend at an angle.

[0062] It is preferred that when two display fixtures 10, 36 are used, the horizontal shelves 24, 26 may attach on one display fixture 10 at one end and attach at its opposite end on an adjacent display fixture 36. Therefore, the longer shelf 26 could extend the entire width of both display fixtures 10, 36 or any variation in between. This ensures that an unlimited number of display fixtures 10 can be aligned adjacent to lateral edges 20, 22 to allow for any length, position, or number of shelves 24, 26 to be positioned on the display fixture assembly.

[0063] The present invention also provides a shelf having a rail on a bottom surface of the shelf. A vertical partition 28 having a bracket mounts to the rail so that the vertical partition may slide along the rail to position the vertical partition on the back panel 12. Thus, the vertical partition 28 does not attach to the back panel 12, but may still be positioned at any location between the lateral edges 20, 22 of the back panel. Additionally, if more than one display fixture 10 is used, a shelf could span across two adjacent display fixtures 10, 36 such that the vertical partition 28 could slide along the rail between two display fixtures. A vertical partition 28 having a bracket could be of various lengths depending on where the shelf is attached to the back panel 12. For example, a shorter vertical partition 28 could be used when a shelf is located below the top edge 18 on the back panel 12.

[0064] Although this particular shelf embodiment is shown as having a rail, it is understood that the shelf should not be limited to a rail. Thus, there could be a groove within

the bottom surface of the shelf, where a vertical partition **28** has a “T-shaped” bracket that fits within the groove and is capable of sliding within the groove. Alternatively, the shelf could include bearings press fit within the groove, where the vertical partition **28** has a bracket that fits within the groove and freely slides therein. Thus, any number of techniques could be used to mount the vertical partition **28** to the underside of the shelf to allow the vertical partition to be positioned at various locations along the back panel **12**.

[0065] FIGS. 9-10 also illustrate that each shelf **24** preferably includes two brackets **56** that attach the shelf to the back panel **12**. Similarly, FIG. 5 demonstrates that shelf **26** includes a bracket **56** on opposing ends. Each bracket **56** includes a top portion having an “L-shape” and a bottom planar portion. The top “L-shape” portion is positioned between an upper wire **50** and lower wire **52** of the horizontal wires **42** that serves to support the shelf **24, 26** on the back panel **12**, as shown in FIGS. 9, 11. The planar portion of the bracket **56** extends downwardly and rests adjacent to a second upper wire **50** that serves to prevent the shelf **24, 26** from tipping when weight is applied downwardly on the planar surface of the shelf. Therefore, given the multitude of horizontal wires **42** on the back panel **12**, the shelf **24, 26** may be positioned at various vertical and horizontal locations on the wire grid **40** by reattaching or sliding the shelves to different positions on the back panel.

[0066] As described above for the vertical partition **28**, the shelf **24, 26** may slide between the vertical wires **44**, or the wire grid **40** may alternatively have no vertical wires such that the shelf may slide freely between the lateral edges **20, 22**. Also, in alternative embodiments longitudinal slots **48** or slat board could be used, which would allow the shelf **24, 26** to slide freely between the lateral edges **20, 22**.

[0067] Although FIGS. 9, 11 illustrate a back panel **12** having wire grid **40** thereon, it is understood that longitudinal slots **48** such as those shown in the end panel **30**, or slots defined by slat board could be used that provide slots where the bracket **56** could be inserted within the slots to attach either shelf **24, 26** to the back panel. Thus, the shelves **24, 26** could be mounted on the back panel **12** through the longitudinal slots **48** or slots defined by slat board at several different horizontal and vertical positions. In addition, the longitudinal slots **48** or slots defined by slat board would be capable of accommodating different sized shelves **24, 26**. It is understood that different brackets **56** could be used with different wire grid **40** patterns, longitudinal slots **48**, or slat board. Thus, the bracket **56** is not limited to the L-shaped and planar portions as described above, as the bracket could be adapted to fit within various wire grids **40** or other similar designs capable of receiving a bracket **56**.

[0068] Similarly, although FIGS. 7-8 illustrate a back panel **12** having wire grid **40** thereon, it is understood that longitudinal slots **48** such as those shown in the end panel **30**, or in slots defined by slat board could be used that provide slots where the vertical partition **28** could be attached to the back panel. Thus, the vertical partition **28** could alternatively include brackets **56** that allow the vertical partition to attach to the longitudinal slots **48** or slots defined by slat board. Thus, the vertical partition **28** could be mounted on the back panel **12** through the longitudinal slots **48** or slots defined by slat board at several different horizontal and vertical positions. In addition, the longitudinal

slots **48** or slat board would be capable of accommodating different sized vertical partitions **28**.

[0069] In alternative embodiments, the vertical partition **28** may include recesses **64** or a grid **66** on opposed sides of the vertical partition, as shown in FIGS. 12-13. The recesses **64** are preferably arranged on both sides of the vertical partition **28** in two columns extending substantially the entire length of the vertical partition. The recesses **64** could extend partially through the vertical partition **28** on one or both sides, or the recesses could extend entirely through the vertical partition. The grid **66** has horizontal slots defined within the vertical partition **28**, and the grid could include wire grid **40**, longitudinal slots **48** such as those in the end panel **30**, or slat board.

[0070] As shown in FIG. 14, each shelf **65** may have protrusions **68** extending from each of its opposed lateral edges that are capable of fitting within the recesses **64** of the vertical partition **28** to provide support to the shelf. The shelf **65** includes a wire grid support surface having hooks or the like at each end that insert within the recesses **64**, wherein the hooks rest against a bottom surface of the recesses to support the shelf. Similarly, each shelf **24** could have brackets mounted on its edges that attach to the grid **66** in a similar manner as the brackets **56** attach to the wire grid **40**, longitudinal slots **48**, or slat board on the back panel **12**, as discussed previously. In addition, the shelf **65** could be supported by vertical partitions **28** having a grid **66** defined therein, and in alternative embodiments shelf **24** may include protrusions **68** or brackets that may be used in conjunction with a vertical partition having recesses **64** defined therein. Preferably the shelf **24, 65** is supported on both lateral sides with two vertical partitions **28** as illustrated in FIGS. 12-13, but could be supported by only one vertical partition **28** on one side in alternative embodiments.

[0071] It is understood that although the shelf **65** is shown as a wire grid with hook protrusions **68** at each end, the shelf should not be limited to a grid and could be any suitable shelf capable of mating with the recesses **64** to provide a surface to support a variety of merchandise. In addition, it is also understood that although the recesses **64** are shown as two columns along the vertical partition, the recesses could be any number of recesses and variety of shapes and sizes that accommodate the protrusions **68** and the like.

[0072] FIGS. 12-13 show the shelf **24, 65** supported by vertical partitions **28**. This arrangement gives the display fixture **10** the option of separating merchandise or items vertically with the vertical partitions **28** as well as horizontally using the shelves **24, 65**. Although the display fixture **10** is illustrated in FIGS. 12-13 as having shelves **24, 65** supported between vertical partitions **28**, it is understood that longer shelves **26** could be mounted between two vertical partitions **28** in alternative embodiments. In addition, either shelf **24, 26** supported by the grid **66** with bracket **56**, or the shelf **65** supported by recesses **64**, could be used in combination with the wire grid **40**, longitudinal slots **48** such as those used in the end panel **30**, or slat board on the back panel **12**. This arrangement would give the shelves **24, 26, 65** the greatest amount of support, such as for heavier items.

[0073] In another embodiment of the present invention, the display fixture **10** has a groove **70** extending substantially along the length of the top edge **18** of the back panel

12, as shown in FIGS. 15-16. The end panel 30 may also have a groove 70 defined therein where a display panel 72 may be inserted. The groove 70 accommodates a display panel 72, where the display panel fits within the groove such that it is supported in a vertical position, while also being able to slide. The display panel 72 can advantageously be positioned in locations coinciding with the desired location of the merchandise or item being displayed. Thus, if the vertical partition 28 or shelves 24, 26 are moved to different locations, the display panel 72 can be similarly positioned to correspond to the new location of the vertical partition or shelves.

[0074] FIG. 16 illustrates that there may be two substantially parallel grooves 70 extending along the top edge 18 of the back panel 12. Providing two grooves 70 enables display panels 72 for merchandise or items displayed on either side of the display fixture 10. It is also understood that two display fixtures 10, 36 could be positioned such that their lateral edges 20, 22 were adjacent to one another in an end-to-end relationship, such that their top edges 18 provide a continuous groove 70 for display panels 72. Alternatively, the back panels 12 of each display fixture 10, 36 could be positioned adjacent to one another such that their top edges 18 provide two rows of grooves 70 to accommodate display panels 72. In either case, this would allow the display fixture 10 to be placed in an open space, as opposed to adjacent to a wall, such that merchandise could be displayed on either side of the display fixture, as shown in FIG. 15.

[0075] In addition, the display panel 72 may also be of different sizes depending on the type of product or message to be presented. As shown in FIGS. 3-5, different lengths of display panels 72 may be used such that a longer display panel may be used with longer shelves 26, and shorter display panels may be used between vertical partitions 28. It is also understood that if two adjacent display fixtures 10, 36 are used, that a display panel 72 could span between the adjacent display fixtures across the lateral edges 20, 22 of the respective display fixtures. This would give the display fixture assembly a full range of display variations given that the vertical partitions 28 and shelves 24, 26 are capable of spanning across multiple display fixtures 10 as well.

[0076] In yet another embodiment, the present invention includes an extension 74 having wire grid 40, longitudinal slots 48 such as those used in the end wall 30, or slat board thereon, as well as support bars 76 extending on opposite ends of the extension, as illustrated in FIG. 17. The support bars 76 fit within openings 78 defined with the support ends 14 of the back panel 12. The support bars 76 have a "bayonet" shape such that the support bars slide within the openings 78 until a flange on the support bar stops the support bar at a predetermined position, while at the same time supporting the extension in a vertical position. It is preferred that the extension 74 has a groove 70 or two parallel grooves defined within its top edge 18, as discussed above, so that a display panel 72 may fit therein.

[0077] As illustrated in FIG. 18, the extension 74 is positioned on the back panel 12 so as to provide additional area for attaching vertical partitions 28 or shelves 24, 26. A vertical partition 28 could therefore attach at one end to the wire grid 40, longitudinal slots 48, or slat board on the extension 74 and extend downward and attach at its opposite end to the wire grid, longitudinal slots, or slat board on the

back panel 12. Thus, with the capability of aligning adjacent display fixtures 10 horizontally and providing extensions 74 vertically, the display fixture is unrestrained in its amount of expandability.

[0078] Although the illustrated extension 74 has bayonet style support bars 76, the extension should not be limited to this style. For example, FIG. 19 demonstrates that the extension 74 could have support bars 76 that slide within the openings 78 in the support ends 14, and the back panel 12 could have a top edge 18 that provides an opening, such that the extension could be lowered into the back panel 12 or entirely enclosed within the back panel when not in use. Thus, the top edge 18 of the extension 76 could serve as the top edge of the display panel when the extension is lowered into or raised out of the back panel. Alternatively, the top edge 18 of the back panel 12 could be hinged so that the extension 74 is not exposed when inoperative, or the top edge could be completely removed from the back panel when the extension is raised out of the back panel and mounted in place to the support ends 14. The extension 74 could subsequently be slid out of the back panel 12 and locked into an operative position using spring locks, cotter pins, clevis pins, or the like.

[0079] Many modifications and other embodiments of the invention set forth herein will come to mind to one skilled in the art to which this invention pertains having the benefit of the teachings presented in the foregoing descriptions and the associated drawings. Therefore, it is to be understood that the invention is not to be limited to the specific embodiments disclosed and that modifications and other embodiments are intended to be included within the scope of the appended claims. Although specific terms are employed herein, they are used in a generic and descriptive sense only and not for purposes of limitation.

That which is claimed:

1. A display fixture for displaying merchandise, the display fixture comprising:

a generally vertical back panel having opposed lateral edges and opposed top and bottom edges, the back panel defining at least one engageable member extending in a generally horizontal direction between the lateral edges; and

at least one generally vertical partition comprising at least one cooperative engaging member removably attached to the engageable member of the back panel, wherein the vertical partition extends substantially between the top and bottom edges of the back panel, wherein the vertical partition further extends generally orthogonal from the back panel and generally orthogonal to the engageable member on the back panel, and wherein the vertical partition is slidable in a lateral direction to define variable lateral positions on the back panel.

2. A display fixture according to claim 1, wherein the back panel comprises a plurality of engageable members.

3. A display fixture according to claim 2, wherein each engageable member comprises two generally parallel wires.

4. A display fixture according to claim 2, wherein each engageable member comprises two adjacent slat boards defining a gap therebetween.

5. A display fixture according to claim 1, further comprising at least one generally horizontal shelving member having a cooperative engaging member removably attached

to the engageable member of the back panel to define a support surface, wherein the horizontal shelving member is slidable in a lateral direction to define variable lateral positions on the back panel.

6. A display fixture according to claim 1, wherein the back panel further comprises a generally vertical back panel extension defining at least one engageable member therein, wherein the back panel extension is joined to the top edge of the back panel such that the back panel defines an increased number of engageable members.

7. A display fixture according to claim 6, wherein the vertical partition has a first cooperative engaging member removably attached to the engageable member of the back panel extension and a second cooperative engaging member removably attached to the cooperative engageable member of the back panel, such that the vertical partition overlaps a bottom edge of the back panel extension and the top edge of the back panel.

8. A display fixture according to claim 6, wherein the back panel further defines an internal cavity having an opening in the top edge such that the back panel extension may be stored within the back panel in an inoperative position and raised out of the back panel and joined to the back panel in an operative position.

9. A display fixture according to claim 1, wherein the back panel defines a front surface and a back surface generally orthogonal to the lateral edges and to the top and bottom edges, and wherein the engageable member of the back panel is capable of receiving the vertical partition on the front surface and the back surface of the back panel.

10. A display fixture according to claim 1, further comprising a support base having a plurality of wheels attached thereto, such that the back panel is transportable.

11. A display fixture according to claim 1, further comprising an end panel attached generally orthogonal to a lateral edge of the back panel, wherein the end panel includes at least one engageable member extending in a generally transverse direction to the engageable member defined in the back panel, wherein the engageable member in the end panel is capable of receiving at least one generally horizontal shelving member.

12. A display fixture according to claim 1, further comprising a second back panel positioned adjacent to a lateral edge of the first back panel such that the first and second back panels are end-to-end.

13. A display fixture according to claim 12, wherein a generally horizontal shelving member is removably attached to at least one engageable member in the back panel and the second back panel such that the horizontal shelving member overlaps adjacent lateral edges on the first and second back panels, wherein the horizontal shelving member is slidable in a lateral direction to define variable lateral positions on the first and second back panels.

14. A display fixture for displaying merchandise, the fixture comprising:

a generally vertical back panel having opposed lateral edges, a top edge defining a generally horizontal surface, and a bottom edge opposite the top edge, wherein the top edge defines at least one groove that extends in a generally horizontal direction between the opposed lateral edges of the back panel; and

at least one generally vertical display panel removably inserted within the groove of the top edge such that the

display panel is laterally slidable within the groove to define variable lateral positions on the top edge.

15. A display fixture according to claim 14, further comprising at least one generally vertical partition removably attached to the back panel such that at least one display panel is positioned laterally proximate to the vertical partition.

16. A display fixture according to claim 14, wherein the top edge defines a second groove that is substantially parallel to the first groove such that at least one display panel is removably inserted and laterally slidable within each groove.

17. A display fixture for displaying merchandise, the fixture comprising:

a generally vertical back panel having opposed lateral edges and opposed top and bottom edges, the back panel defining at least one engageable member extending in a generally horizontal direction between the lateral edges;

at least one generally vertical partition having at least one cooperative engaging member removably attached to the engageable member of the back panel, wherein the vertical partition further extends generally orthogonal from the back panel and generally orthogonal to the engageable member on the back panel, and wherein the vertical partition is slidable in a lateral direction to define variable lateral positions of the vertical partition, and wherein each vertical partition defines at least one engageable member in a lateral edge of the vertical partition; and

at least one generally horizontal shelving member having opposed lateral edges and comprising at least one cooperative engaging member on a lateral edge of the horizontal shelving member, wherein the cooperative engaging member of the horizontal shelving member is inserted within the engageable member of the vertical partition such that the horizontal shelving member is supported by the vertical partition to provide a support surface.

18. A display fixture according to claim 17, wherein the engageable member of the vertical partition comprises an elliptical recess defined within the lateral edge of the vertical partition.

19. A display fixture according to claim 17, wherein the engageable member of the vertical partition comprises two generally parallel and horizontal wires defined within the lateral edge of the vertical partition.

20. A display fixture according to claim 17, wherein the vertical partition extends substantially between the top edge and the bottom edge of the back panel.

21. A display fixture according to claim 17, wherein the horizontal shelving member further comprises at least one cooperative engaging member on opposed lateral edges of the horizontal shelving member such that the horizontal shelving member is removably attached to an engageable member of the vertical partition on each lateral edge of the horizontal shelving member to provide a support surface.

22. A method for assembling a merchandise display fixture, the method comprising the steps of:

providing a generally vertical back panel having opposed lateral edges and opposed top and bottom edges, the

back panel defining at least one engageable member extending in a generally horizontal direction between the lateral edges; and

attaching at least one generally vertical partition to the back panel, wherein the vertical partition includes at least one cooperative engaging member removably attached to the engageable member of the back panel, wherein the vertical partition extends substantially between the top and bottom edges of the back panel, wherein the vertical partition further extends generally orthogonal from the back panel and generally orthogonal to the engageable member on the back panel, and wherein the vertical partition is slidable in a lateral direction to define variable lateral positions of the vertical partition.

23. The method according to claim 22, further comprising sliding the at least one vertical partition in a lateral direction from a first lateral position to a second lateral position on the back panel.

24. The method according to claim 22, further comprising attaching at least one cooperative engaging member on at least one generally horizontal shelving member to the engageable member of the back panel to define a support surface, wherein the horizontal shelving member is slidable in a lateral direction to define variable lateral positions on the back panel.

25. The method according to claim 24, further comprising removing the vertical partition and the horizontal shelving member from the back panel, and attaching at least one cooperative engaging member on at least one elongated generally horizontal shelving member to the engageable member of the back panel to define a support surface, wherein the elongated generally horizontal shelving member extends substantially between the lateral edges of the back panel.

26. The method according to claim 22, further comprising inserting at least one cooperative engaging member on each lateral edge of a generally horizontal shelving member into

at least one engageable member defined in a lateral edge of the vertical partition such that the horizontal shelving member is supported by the vertical partition on at least one lateral edge to define a support surface.

27. The method according to claim 22, further comprising connecting a generally vertical back panel extension to the top edge of the back panel, wherein the back panel extension extends in a generally vertical direction from the top edge of the back panel and defines at least one engageable member therein.

28. The method according to claim 27, further comprising attaching a first cooperative engaging member of the vertical partition to the engageable member of the back panel extension, and attaching a second cooperative engaging member of the vertical partition to the engageable member of the back panel, such that the vertical partition overlaps a bottom edge of the back panel extension and the top edge of the back panel.

29. The method according to claim 22, further comprising storing a generally vertical back panel extension having at least one engageable member therein in an internal cavity having an opening defined within the top edge of the back panel in an inoperative position, and raising the back panel extension out of the top edge of the back panel and joining the back panel extension to the back panel in an operative position.

30. The method according to claim 22, further comprising providing a second back panel positioned adjacent to a lateral edge of the back panel such that the first and second back panels are end-to-end.

31. The method according to claim 30, further comprising attaching at least one cooperative engaging member on at least one generally horizontal shelving member to at least one engageable member in the back panel and the second back panel such that the horizontal shelving member overlaps the lateral edge of the first back panel and an adjacent lateral edge of the second back panel.

* * * * *