



US00D772039S

(12) **United States Design Patent** (10) **Patent No.:** **US D772,039 S**
Onuki (45) **Date of Patent:** **** Nov. 22, 2016**

- (54) **FIXING DEVICE FOR ROOF RAIL OF VEHICLE**
- (71) Applicant: **FALTEC Co., Ltd.**, Kawasaki-shi, Kanagawa-ken (JP)
- (72) Inventor: **Soji Onuki**, Kawasaki (JP)
- (73) Assignee: **FALTEC Co., Ltd.**, Kawasaki-shi (JP)
- (**) Term: **14 Years**
- (21) Appl. No.: **29/507,675**
- (22) Filed: **Oct. 30, 2014**
- (51) **LOC (10) Cl.** **08-08**
- (52) **U.S. Cl.**
USPC **D8/349**
- (58) **Field of Classification Search**
USPC D8/349, 354; D12/223; D14/451, 452, D14/217; 248/278.1, 284.1, 274.4, 200, 248/300, 534, 678
CPC B60Q 1/302; B60Q 1/30; B60R 9/058; B60R 9/00; B60R 9/055; H01R 13/639; H01R 13/629
See application file for complete search history.

(56) **References Cited**

- U.S. PATENT DOCUMENTS
- 5,181,774 A * 1/1993 Lane B62J 6/02 224/421
- 5,306,156 A * 4/1994 Gibbs B60Q 1/302 224/315

(Continued)

- FOREIGN PATENT DOCUMENTS
- JP 2000-280756 A 10/2000
- Primary Examiner — Mark Goodwin
- (74) Attorney, Agent, or Firm — Mots Law, PLLC

(57) **CLAIM**

The ornamental design for a fixing device for roof rail of vehicle, as shown and described.

DESCRIPTION

FIG. 1 is a top, front perspective view of a fixing device for roof rail of vehicle showing my new design;

FIG. 2 is a front elevation view thereof;
 FIG. 3 is a rear elevation view thereof;
 FIG. 4 is a left-side elevation view thereof;
 FIG. 5 is a right side elevation view thereof;
 FIG. 6 is a top plan view thereof;
 FIG. 7 is a bottom elevation view thereof;
 FIG. 8 is a top, front perspective view of a first variation of the embodiment of a fixing device for roof rail of vehicle of FIGS. 1-7;
 FIG. 9 is a front elevation view of the fixing device for roof rail of vehicle of FIG. 8;
 FIG. 10 is a rear elevation view of the fixing device for roof rail of vehicle of FIG. 8;
 FIG. 11 is a left side elevation view of the fixing device for roof rail of vehicle of FIG. 8;
 FIG. 12 is a right side elevation view of the fixing device for roof rail of vehicle of FIG. 8;
 FIG. 13 is a top plan view of the fixing device for roof rail of vehicle of FIG. 8;
 FIG. 14 is a bottom elevation view of the fixing device for roof rail of vehicle of FIG. 8;
 FIG. 15 is a top, front perspective of a second variation of a fixing device for roof rail of vehicle of FIGS. 1-7;
 FIG. 16 is a front view elevation of the fixing device for roof rail of vehicle of FIG. 15;
 FIG. 17 is a rear elevation view of the fixing device for roof rail of vehicle of FIG. 15;
 FIG. 18 is a left side elevation view of the fixing device for roof rail of vehicle of FIG. 15;
 FIG. 19 is a right side elevation view of the fixing device for roof rail of vehicle of FIG. 15;
 FIG. 20 is a top plan view of the fixing device for roof rail of vehicle of FIG. 15; and,
 FIG. 21 is a bottom elevation view of the fixing device for roof rail of vehicle of FIG. 15.
 The portions of the article in broken lines are shown for illustrative purposes only and form no part of the claimed design.
 The lines consisting of alternating long and short dashes indicate conceptual border lines between the claimed portions and the disclaimed portions.

1 Claim, 12 Drawing Sheets

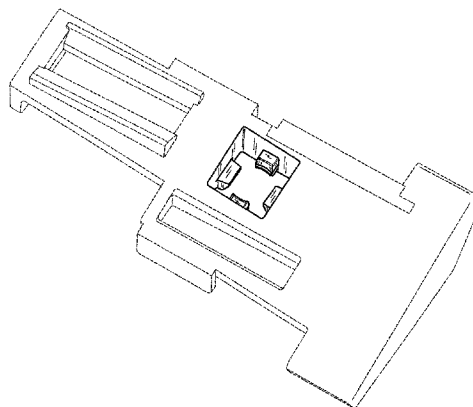

(56)

References Cited

U.S. PATENT DOCUMENTS

5,623,731 A * 4/1997 Ehrgott A41D 19/0027
 2/160
 5,820,093 A * 10/1998 Murray B64D 47/00
 248/274.1
 D487,390 S * 3/2004 Tanaka D8/354
 D542,628 S * 5/2007 Brassard D8/354
 D559,083 S * 1/2008 Brassard D8/354
 D564,864 S * 3/2008 Johnson D8/354
 D571,188 S * 6/2008 Brassard D8/354
 7,887,086 B2 * 2/2011 Kalandek B60R 21/213
 248/200

D633,779 S * 3/2011 Bennett D8/354
 D637,063 S * 5/2011 Gaudron D8/349
 8,177,178 B2 * 5/2012 Carnevali F16M 11/04
 24/618
 D694,228 S * 11/2013 Richter D14/253
 8,970,689 B2 * 3/2015 Campbell H04N 5/2252
 348/335
 9,187,045 B2 * 11/2015 Bittner B60R 9/04
 2011/0095150 A1 * 4/2011 Geier F16B 41/005
 248/220.22
 2013/0062488 A1 * 3/2013 Chen F16M 13/02
 248/222.14
 2014/0217251 A1 * 8/2014 Cheng F16B 47/00
 248/205.3

* cited by examiner

Fig.1

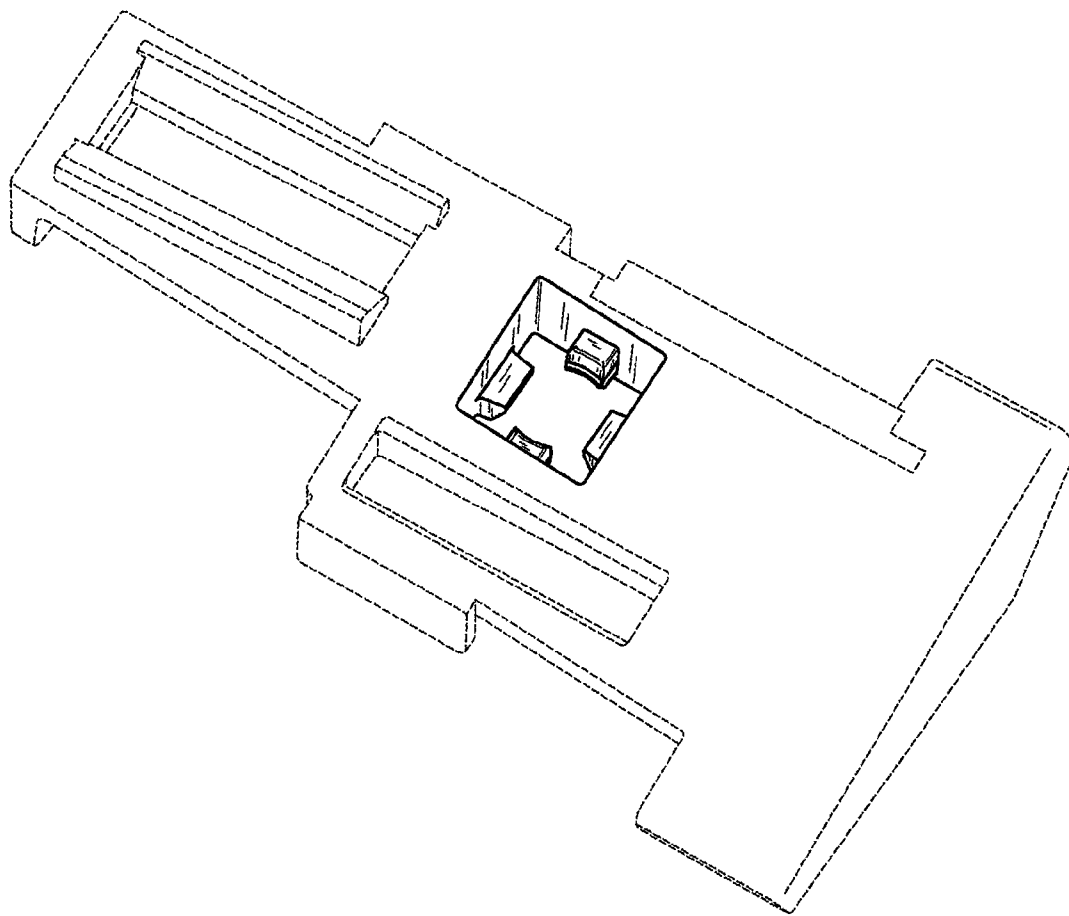

Fig.2

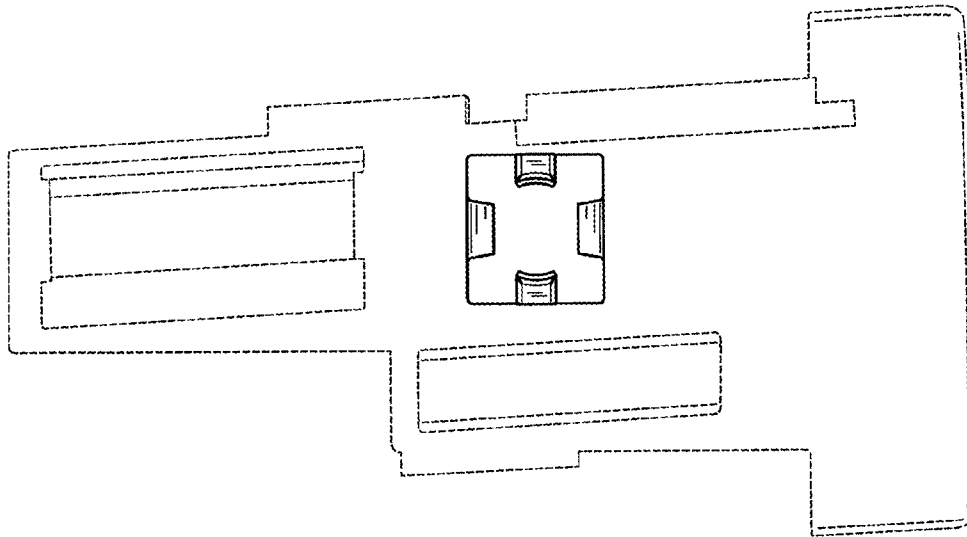

Fig.3

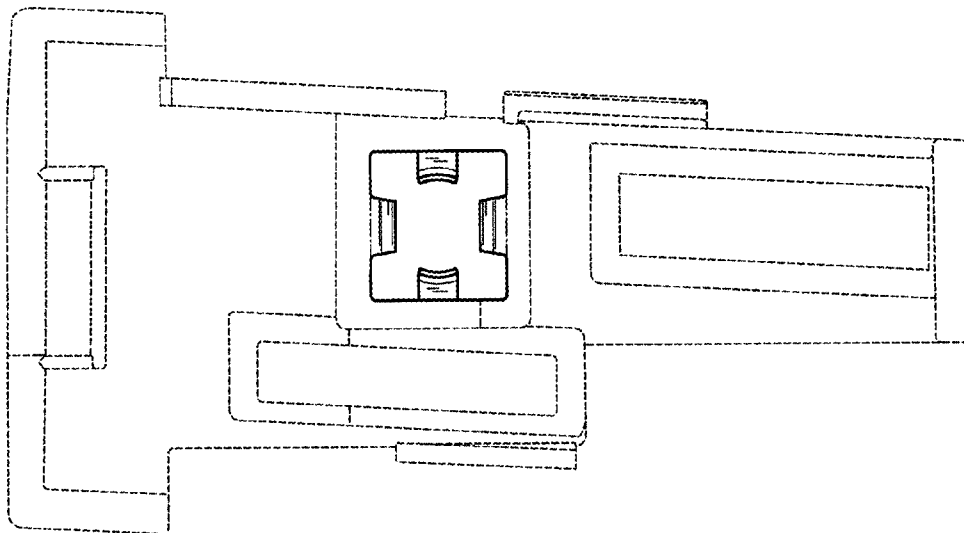

Fig.4

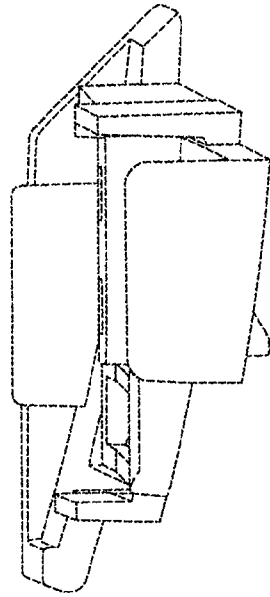

Fig.5

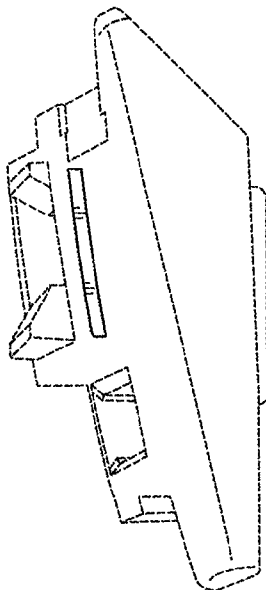

Fig.6

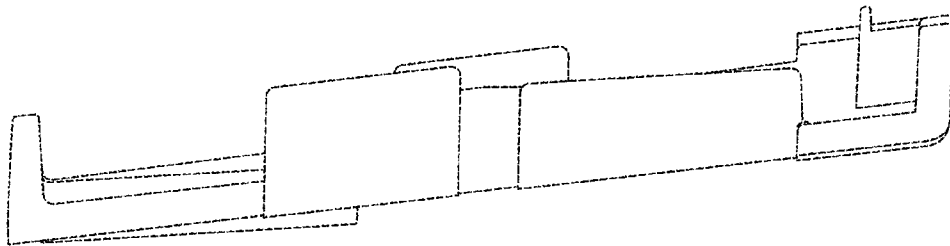

Fig.7

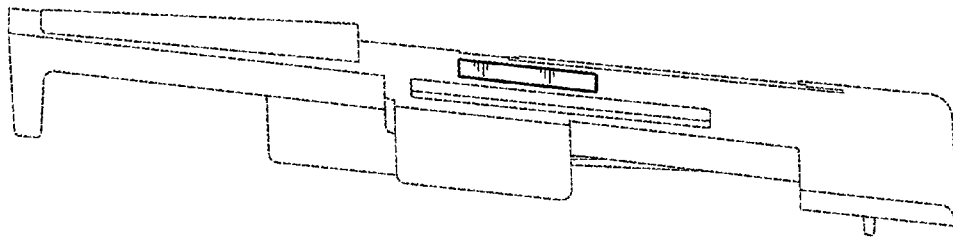

Fig. 8

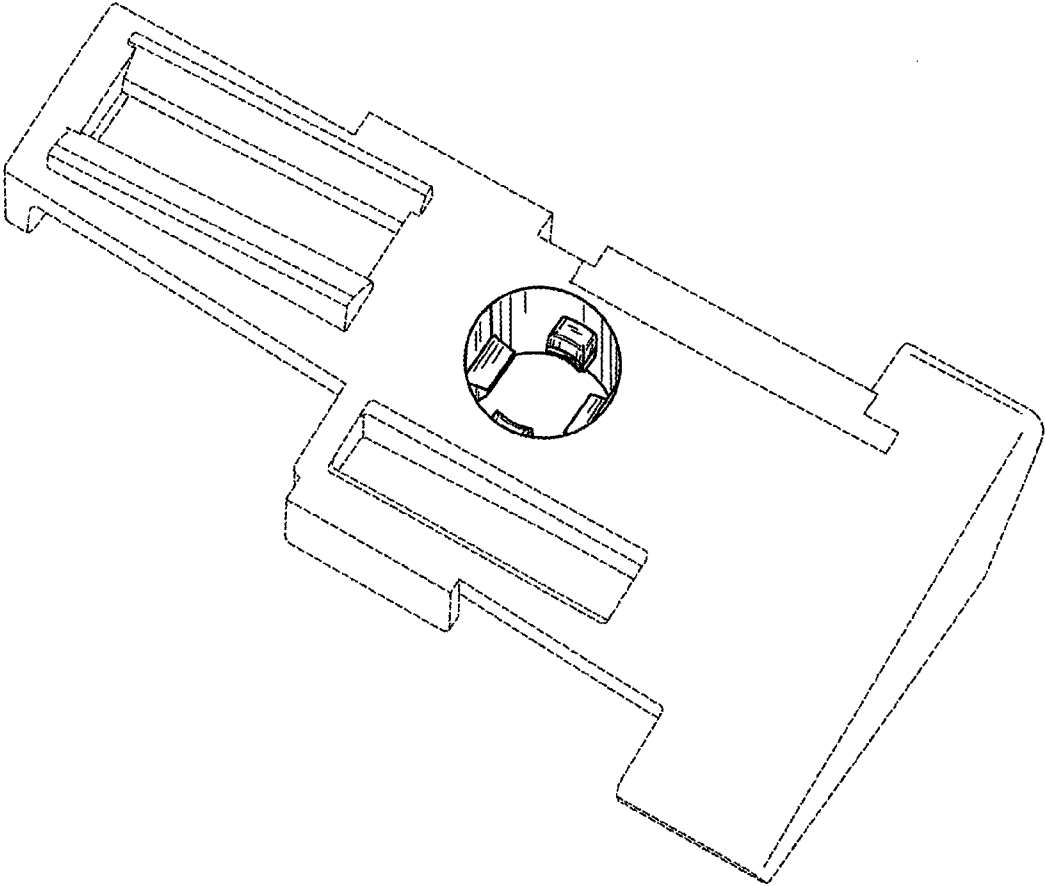

Fig. 9

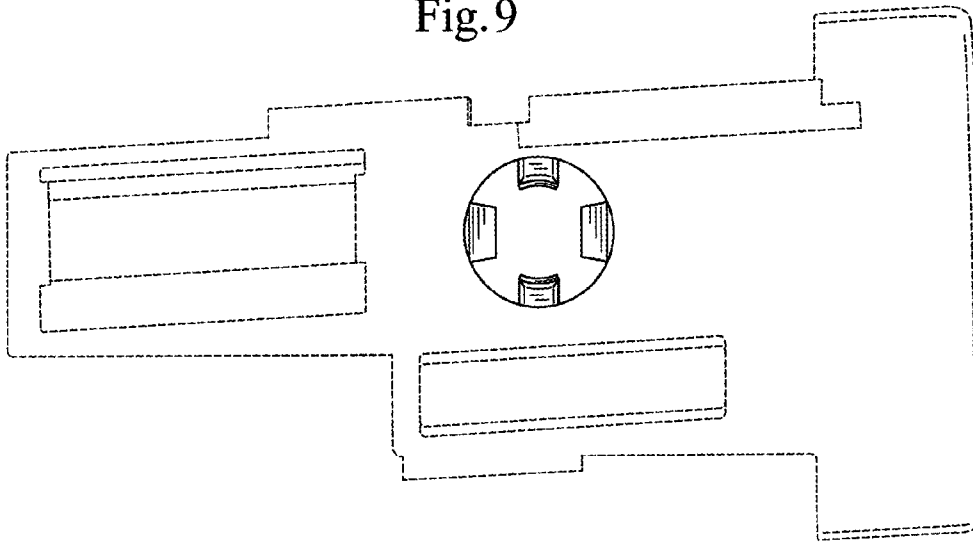

Fig. 10

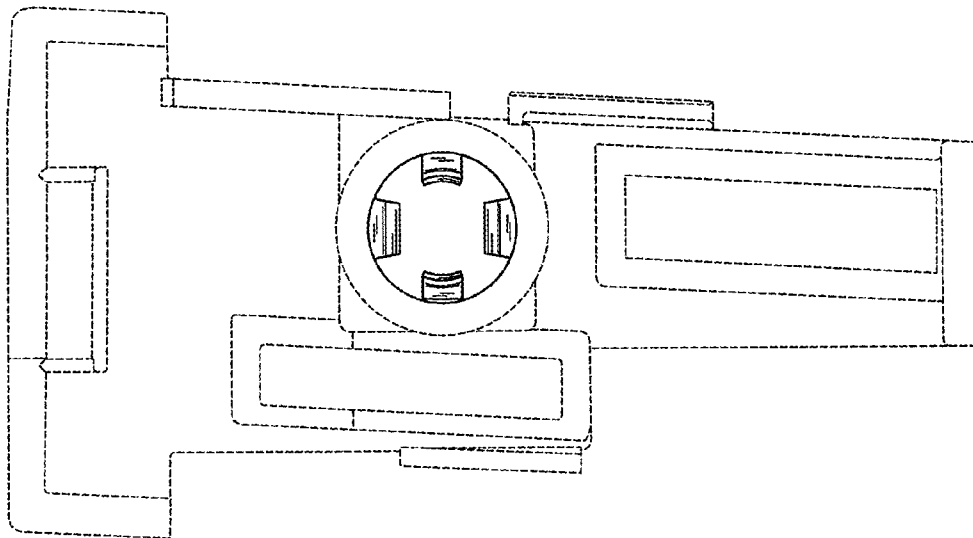

Fig. 11

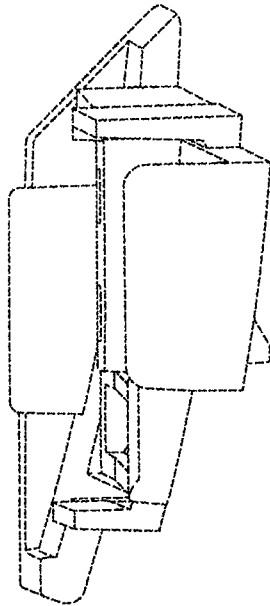

Fig. 12

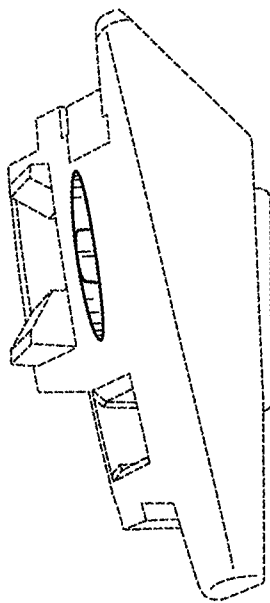

Fig. 13

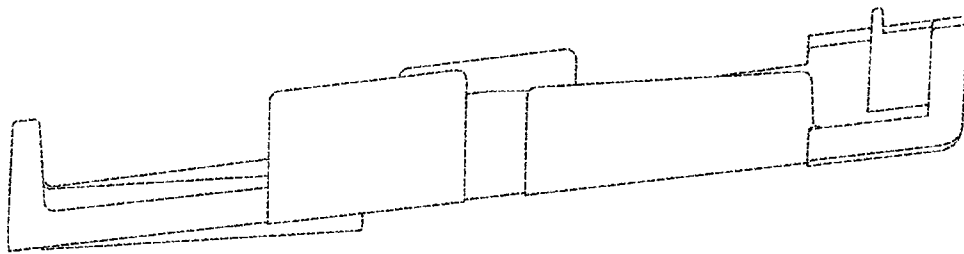

Fig. 14

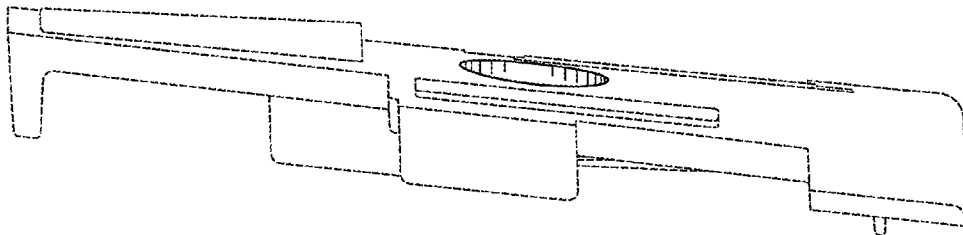

Fig. 15

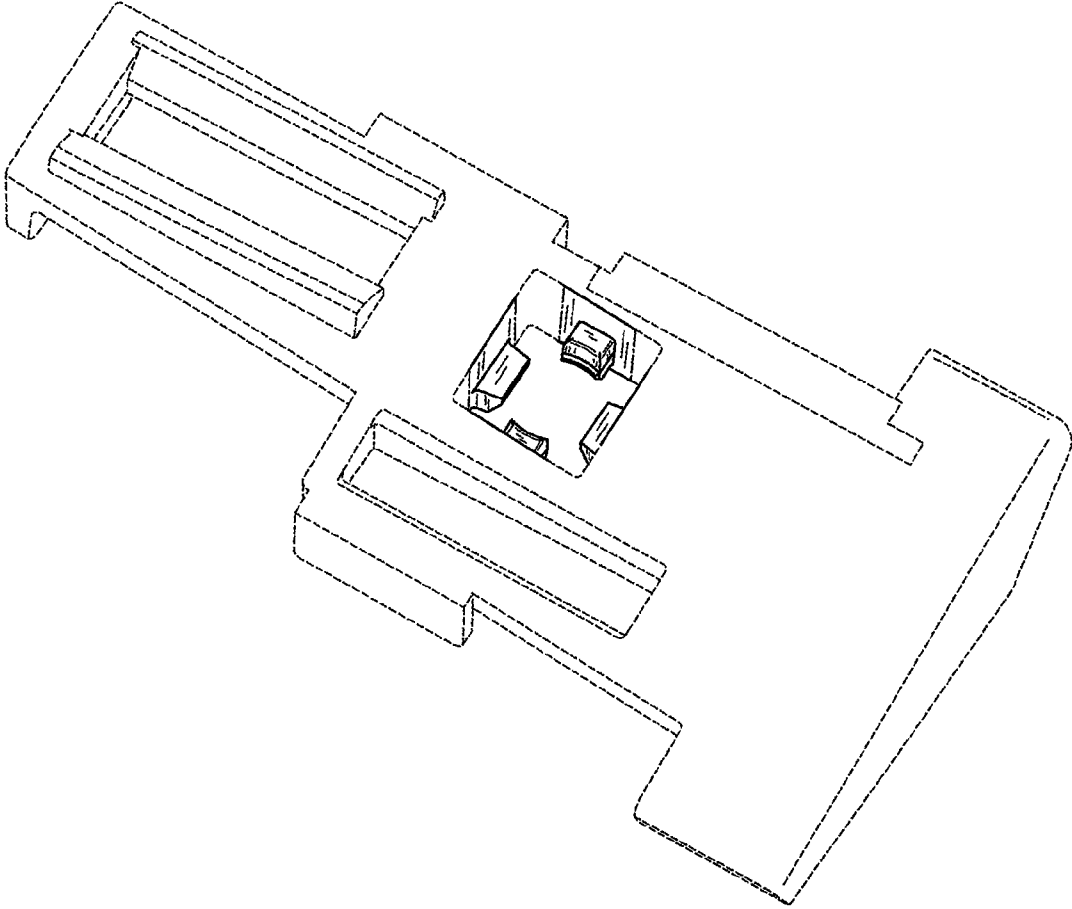

Fig. 16

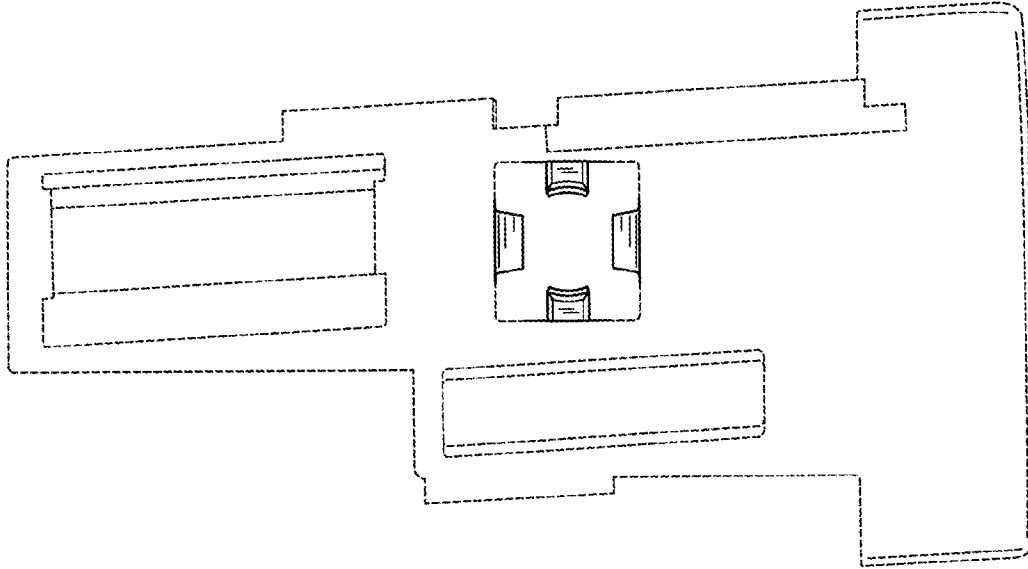

Fig. 17

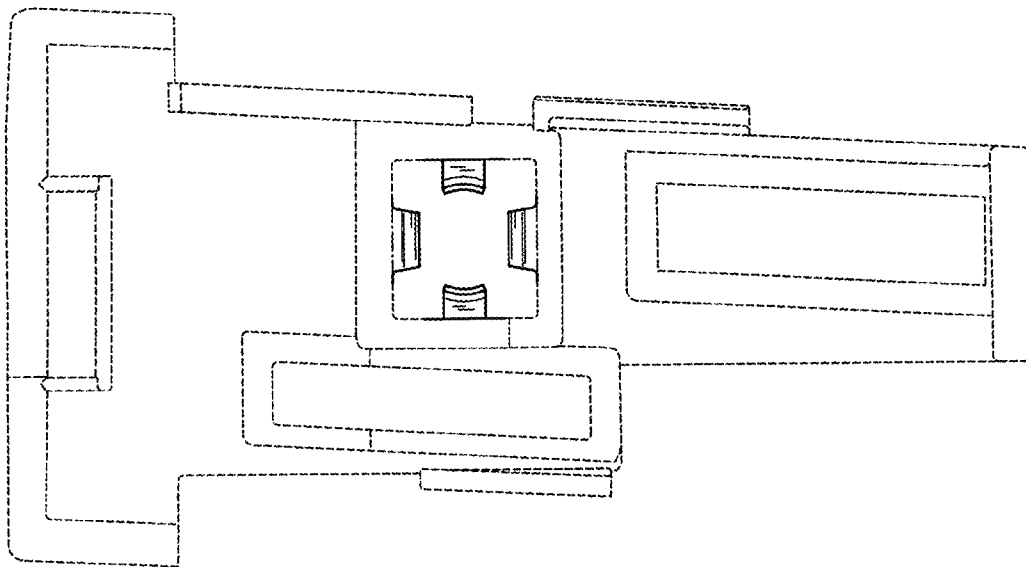

Fig. 18

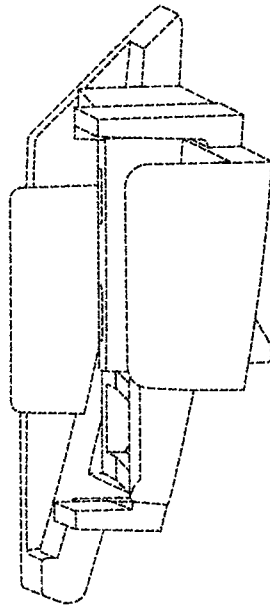

Fig. 19

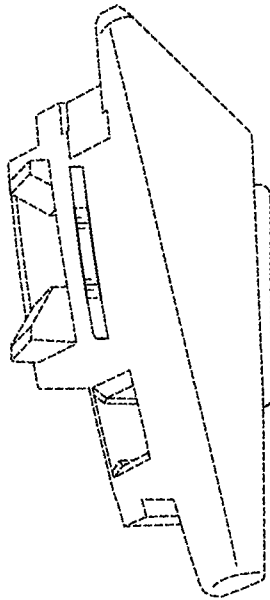

Fig.20

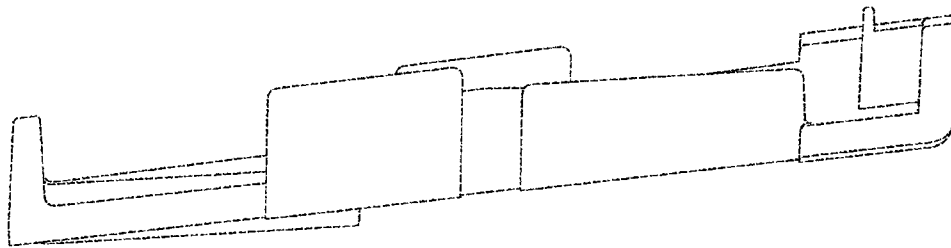

Fig.21

