

(43) Date of A Publication 19.09.2001

(21) Application No 0006418.8

(22) Date of Filing 16.03.2000

(71) Applicant(s)
Nokia Mobile Phones Limited
(Incorporated in Finland)
Keilalahdentie 4, 02150 Espoo, Finland

(72) Inventor(s)
Anders GUNEE
Heikki LAAKSONEN

(74) Agent and/or Address for Service
Nokia IPR Department
Nokia House, Summit Avenue, Southwood,
FARNBOROUGH, Hampshire, GU14 0NG,
United Kingdom

(51) INT CL⁷
H01R 12/22 , H01Q 1/24

(52) UK CL (Edition S)
H2E EAHP ECCC EEGB EEGKR E201 E203
H1Q QKE

(56) Documents Cited
EP 0902508 A2 US 5496182 A US 5490788 A

(58) Field of Search
UK CL (Edition R) **H1Q QKE , H2E ECBF ECCC EEGB**
EEGKR
INT CL⁷ **H01Q , H01R**
Online: EPODOC, JAPIO, WPI

(54) Abstract Title
Antenna connector allowing releasable connection of an antenna to a PCB

(57) An antenna connector 37 releasably holds an antenna 33 against a printed circuit board (PCB) 30 so that the antenna can be removed to allow for repair or replacement of components under the antenna. The antenna connector 37, which is preferably soldered to the PCB 30, has spring contacts 39,40 which engage with a groove 41 in the antenna 33. The antenna 33 may also have snapping members 48 to engage with holes 49 on the PCB 30. Also disclosed is testing probe (fig 7) which can be held against the PCB to test components when the antenna is removed.

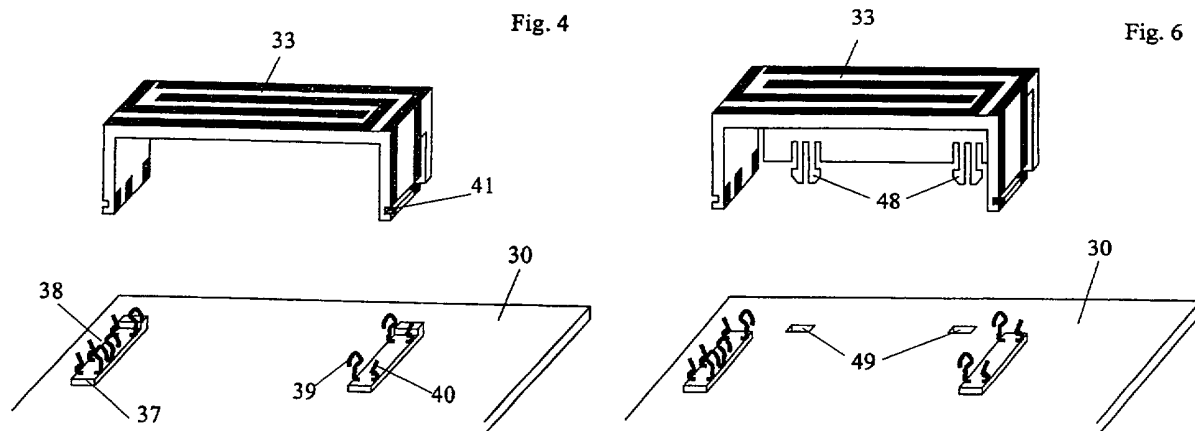

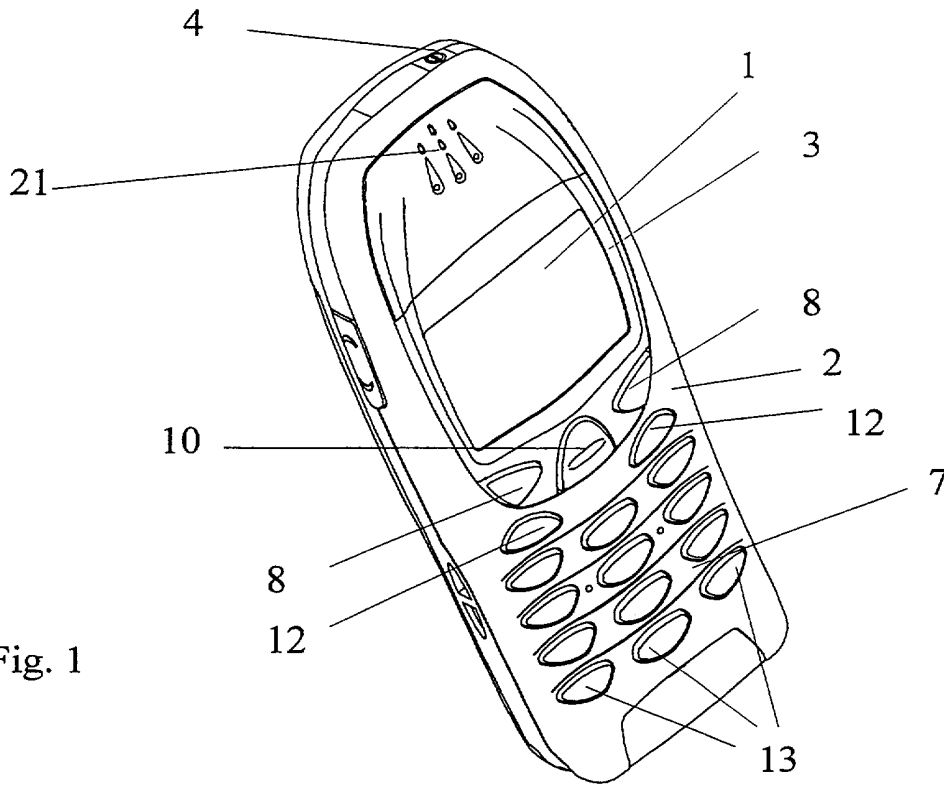

Fig. 1

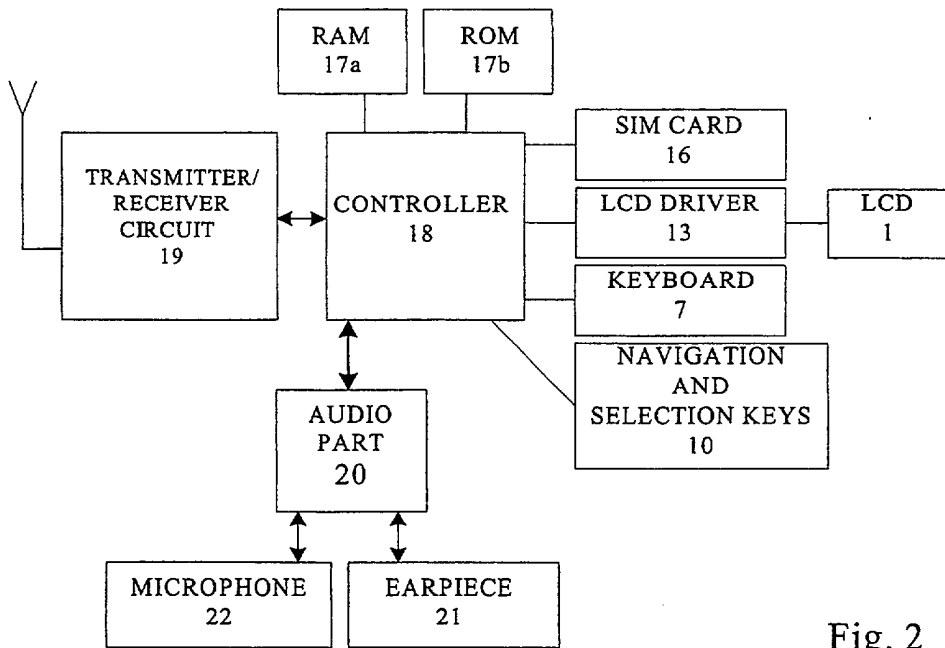

Fig. 2

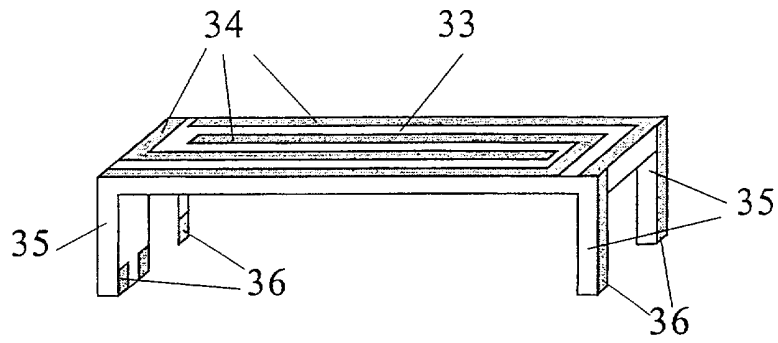

Fig. 3

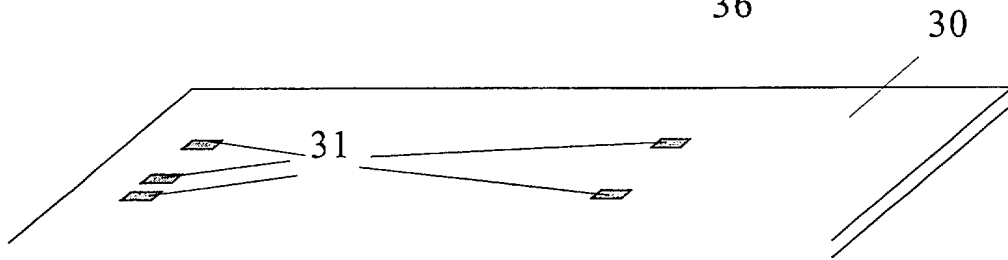
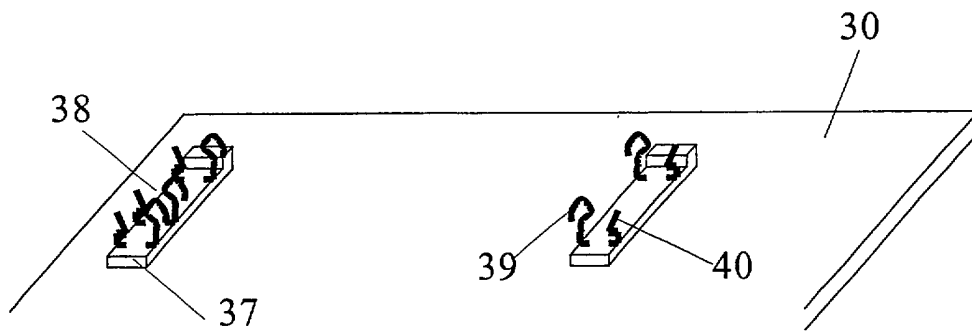
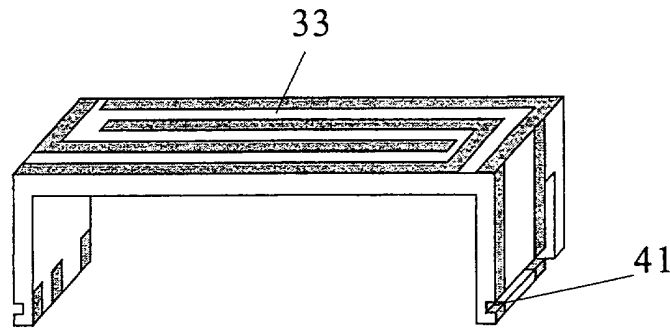

Fig. 4



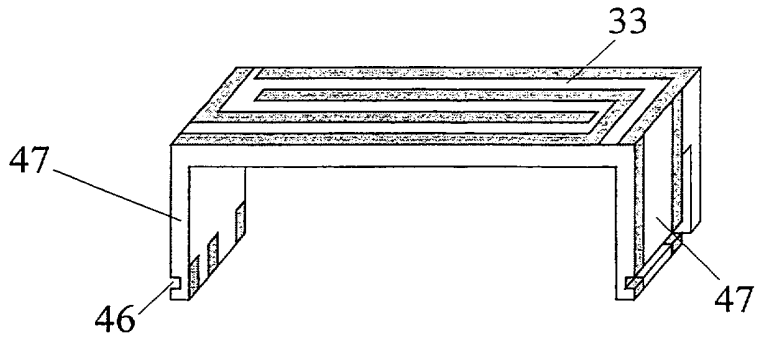

Fig. 5

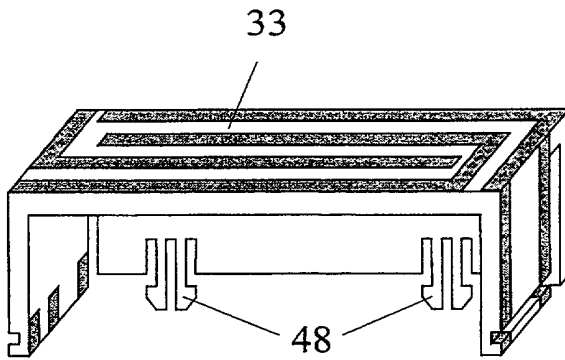
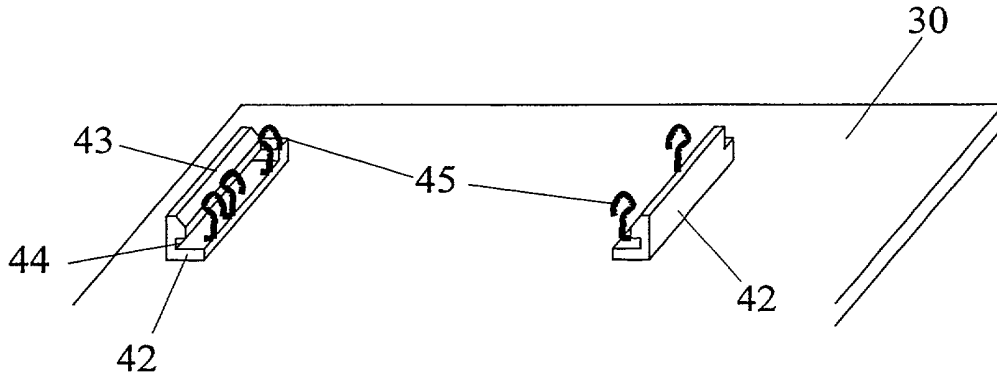
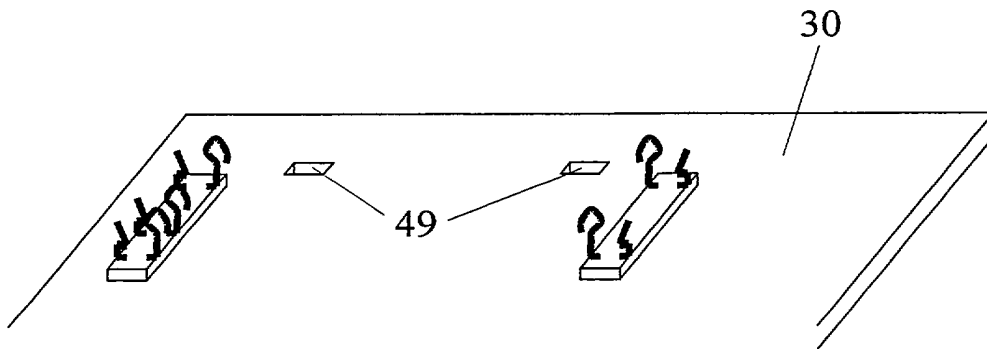

Fig. 6



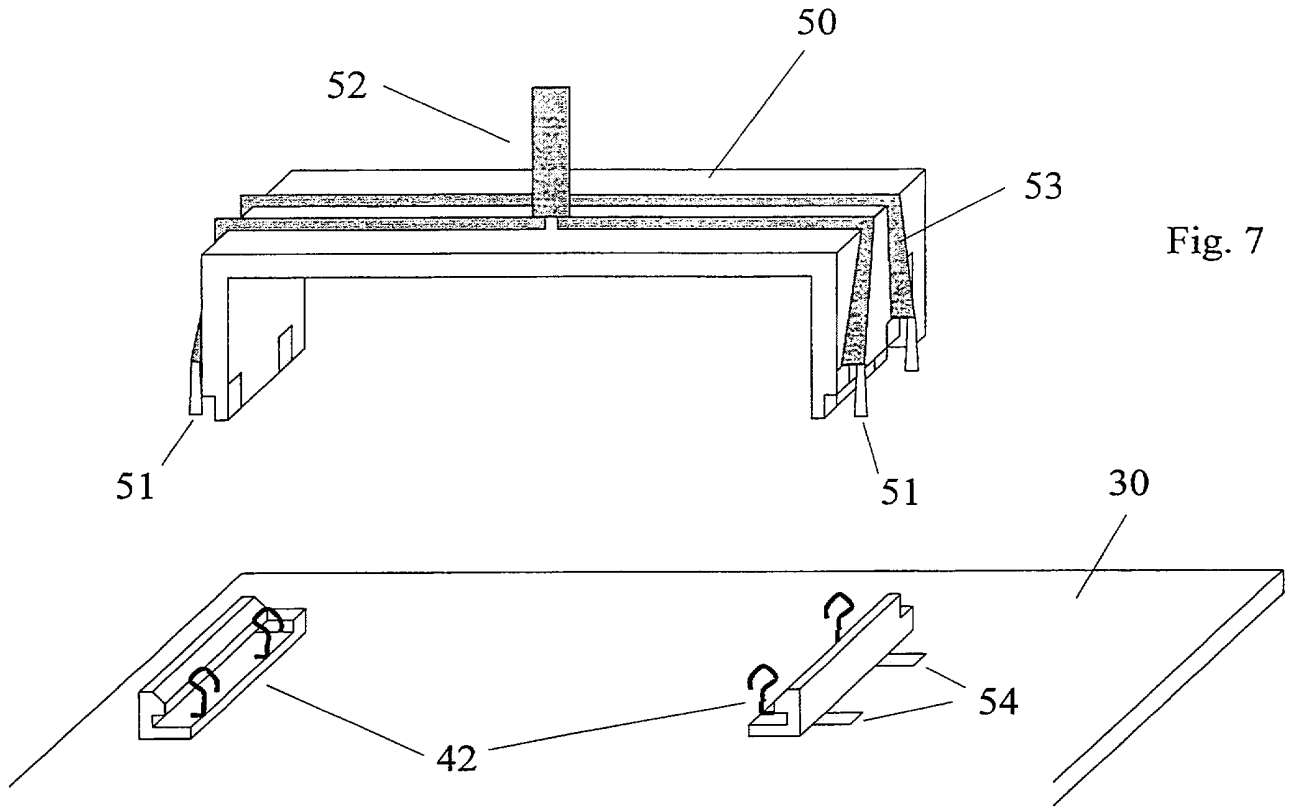

Fig. 7

Antenna connector.

The invention relates to an antenna connector for holding an antenna and a
5 printed circuit board in relation to each other so that there is contact between
the antenna and the printed circuit board.

Electronic devices, e.g. mobile telephones, are getting smaller and smaller
along with the present technological development. This means that all the
10 components in the electronic devices also need to get smaller and smaller and
more and more integrated. These electronic devices have a printed circuit
board, whereon electronic components are mounted during a pick and place
process.

15 When the antenna device becomes smaller and smaller it is desired to place the
device directly onto the printed circuit board during the pick and place process.
The cheapest and the most robust solution would be to solder the antenna
devices onto the printed circuit board. However for mobile phones there is need
for optimising the performance of the radio transmitter and receiver. Therefore it
20 is desired to allow automatical testing of the performance during the testing.
However it is not possible to test the RF stage output when the antenna device
is soldered directly onto the printed circuit board.

In the latest mobile phones there is also a need for having more connections
25 between the radio part and the antenna due to the fact that most mobile phones
are now working in two frequency bands and in the future they will probably use
even more frequency bands.

An object of the invention is to provide an antenna connector that enables that
30 measurements for controlling the characteristics of a radio part on a printed
circuit board can easily be conducted without breaking the antenna and that the

components mounted beneath the antenna can on a later occasion be reached for repairing or checking without breaking the antenna.

According to claimed invention this objective is obtained by an antenna

5 connector for holding an antenna in relation to a printed circuit board, where the antenna connector has means for releasable holding of the antenna onto the printed circuit board and that the holding means of the antenna connector are constructed to enable later flexible removal of the antenna.

10 An object of the invention is to provide a communication unit having a printed circuit board provided with an antenna connector for holding an antenna in relation to a printed circuit board, enabling easy removal of the antenna and availability to components mounted beneath the antenna.

15 According to the claimed invention a communication unit provided with an antenna connector for holding an antenna in relation to a printed circuit board, where the antenna connector has means for releasable holding of the antenna onto the printed circuit board, and that the holding means of the antenna connector are constructed to enable later flexible removal of the antenna.

20

Fig. 1 shows in a perspective view a preferred embodiment of the communication unit according to the invention.

Fig. 2 schematically shows the essential parts of a telephone for communication
25 with a cellular network.

Fig. 3 shows an antenna that will be soldered onto the printed circuit board.

Fig. 4 shows an antenna that will attached to the printed circuit board by an
30 antenna connector.

Fig. 5 shows an antenna that will be attached to the printed circuit board by another antenna connector.

Fig. 6 shows an antenna assembly having extra holding means for attaching the antenna to the printed circuit board.

Fig. 7 shows a schematic view of an antenna probe for conducting measurements and the antenna connector.

10 According to a first aspect the antenna connector according to the invention will be described with reference to a hand portable phone, preferably a cellular/mobile phone. A preferred embodiment of this phone is shown in fig. 1, where a phone is shown in perspective. As will be seen, the phone is provided with a front cover 2 having a window frame 3 encircling the protection window of
15 the display assembly 1. The phone comprises a user interface having an on/off button 4, a keyboard/keypad 7, a battery, a display/LCD 1, an ear-piece 21 and a microphone 22 (not shown).

The keyboard/keypad 7 has a first group of keys 13 as alphanumeric keys, by means of which the user can enter a telephone number, write a text message
20 (SMS), write a name (associated with the phone number), etc. Each of the twelve alphanumeric keys 13 is provided with a figure "0-9" or a sign "#" or "*", respectively. In alpha mode each key is associated with a number of letters and special signs used in the text editing.

25

The keyboard/keypad 7 additionally comprises two soft keys 8, two call handling keys 12, and a navigation key 10. The functionality of the soft key depends on the state of the phone and the navigation in the menu by using a navigation key. The present functionality of the soft keys 8 is shown in separate fields in the
30 display 1 just above the keys 8. The two call handling keys 12 are used for

establishing a call or a conference call, terminating a call or rejecting an incoming call.

5 The navigation key 10 is an up/down key and is placed centrally on the front surface of the phone between the display 1 and the group of alphanumeric keys 13. Hereby the user will be able to control this key with his thumb. This is the best site to place an input key requiring precise motor movements. Many experienced phone users are used to one-hand handling. They place the phone in the hand between the fingertips and the palm of the hand. Hereby the thumb
10 is free for inputting information.

Fig. 2 schematically shows the most important parts of a preferred embodiment of the phone, said parts being essential to the understanding of the invention. The microphone 22 records the user's speech, and the analogue signals formed
15 thereby are A/D converted in an A/D converter (not shown) before the speech is encoded in an audio part 20. The encoded speech signal is transferred to the controller 18 (physical layer processor), which e.g. supports the GSM terminal software. The controller 18 also forms the interface to the peripheral units of the apparatus, including RAM and ROM memories 17a and 17b, a SIM card 16, the
20 display 1 and the keyboard/keypad 7 (from fig. 1) as well as data, power supply, etc. The controller 18 communicates with the transmitter/receiver circuit 19. The audio part 20 speech-decodes the signal, which is transferred from the controller 18 to the ear-piece 21 via a D/A converter (not shown).

25 The preferred embodiment of the phone of the invention is adapted for use in connection with the GSM network, but, of course, the invention may also be applied in connection with other phone networks. It could be cellular networks, various forms of cordless phone systems or in dual band phones accessing sets of these systems/networks.

30

The controller 18 is connected to the user interface. Thus, it is the controller 18, which monitors the activity in the phone and controls the display 1 in response thereto.

- 5 Therefore, it is the controller 18, which detects the occurrence of a state change event and changes the state of the phone and thus the display text. The user may cause a state change event, when he/she activates the keyboard/keypad 7 including the navigation key or keys 10, and these type of events are called entry events or user events. However, the network communicating with the
- 10 phone may also cause a state change event. These type of events and other events beyond the user's control are called non-user events. Non user events comprise status change during call set-up, change in battery voltage, change in antenna conditions, message on reception of SMS, etc.
- 15 The invention will be described in some examples with reference to figs. 3 to 7 showing the various features of an antenna connector.

In fig. 3 a printed circuit board 30 is shown having contact pads 31, and an antenna 33. The antenna includes several transmitting and receiving antennas

20 34. It also includes legs 35. The different transmitting and receiving antennas 34 have parts 36 that extends along the legs 35 of the antenna to enable contact with the contact pads 31 on the printed circuit board 30. The extending parts 36 extend down over the end of the legs 35 and up on the other side of the legs 35. This construction enables better contact between the antenna 33 and the

25 printed circuit board 30. The antenna 33 shown in fig. 3 is soldered onto the printed circuit board 30.

Another solution for attaching an antenna 33 to a printed circuit board 30 is shown in fig. 4, where the antenna 33 is attached to the printed circuit board 30

30 having an antenna connector 37 mounted, preferably by soldering, on the printed circuit board 30. The antenna connectors 37 includes contact members

38 mounted in slots (not shown) on the antenna connector 37, where each contact member 38 includes two contact parts 39 and 40. The first contact part 39 has mainly a contact function, while the second contact part 40 also has a holding function. When an antenna 33 is placed in the connector 37, between
5 the two contact parts 39 and 40, the second contact part 40 will snap into a recession 41 on the antenna 33. The second contact part 40 will hold the antenna 33 firmly so that a good contact is established between the antenna 33 and the printed circuit board 30. If the antenna 33 needs be removed due to maintenance of components placed beneath (not shown) the antenna 33 or that
10 testing of a radio part (not shown) on the printed circuit board 30 and connected to the antenna, the second contact parts 40 can easily be bent outwards from the antenna 33 thus releasing the antenna 33 from the antenna connector 37.

In fig. 5 is yet another way of attaching an antenna 33 to a printed circuit board
15 30 shown, where antenna connectors 42 having a raised section 43 are mounted, preferably by soldering, onto the printed circuit board 30. The raised section 43 of the antenna connector 42 has a recession 44, which overlaps with a corresponding recession 46 on the antenna 33. The antenna connector 42 also includes contact members 45 mounted in slots (not shown) on the antenna
20 connector 42, where the part of the contact members 45 having contact with the antenna 33 has a closed end or at least an end pointing downwards. Any metal parts in the antenna connector 42 will affect the antenna 33, but having a closed end or at least an end pointing downwards minimises the effect from the antenna connector 42 on the antenna 33.

25

In fig. 5 are shown antenna connectors 42 having three and two contact members 45 respectively. To enable the antenna connectors 42 to receive different types of antennas 33 with different numbers of antenna parts the antenna connectors 42 are provided with numerous slots (not shown). For every
30 different type of antenna 33 the antenna connector 42 will be provided with a suitable number of contact members 45, while the rest of the slots will be empty.

Also the embodiments shown in fig. 4 and 6 are provided with numerous slots to adapt to different types of antennas 33.

When an antenna 33 is placed in the antenna connector 42 the contact members 45 will be bend outwards from the raised section 43 until the recession 46 on the antenna 33 snaps into the recession 44 on the antenna connector 42. The contact between the contact members 45 and the antenna 33 is earlier shown described with reference to fig. 3. The antenna 33 is released by pressing the legs 47 inwards and thereby pushing the contact members 45 away, releasing the snapped recessions 44 and 46, and thereafter lifting the antenna 33.

In fig. 6 is shown an antenna 33 having extra holding means 48 for increasing the attaching force between the antenna 33 and the printed circuit board 30. The extra holding means 48 includes snapping members that are inserted in recessions 49 on the printed circuit board 30, when mounting the antenna 33 onto the printed circuit board 30.

In fig. 7 is shown a schematic view of an antenna probe 50 for testing a radio part (not shown) on the print circuit board 30. The antenna probe 50 has some contact cables 52 for connecting to measuring equipment (not shown) and some coax cables 53 to attach to some grounding pins 51. As mentioned earlier there is a need for testing the radio part of a mobile phone to see that the radio parts meet the requirements of certain standards or just to check if the performance of the radio part is satisfactory. The antenna probe 50 has in this example a similar structure to that of the earlier described antennas 33, but it could have any other design as long as the grounding pins 51 fits into the antenna connector 42 and that they are connected to some grounding pads 54. The antenna probe 50 lacks any recessions that corresponds to the recessions 44 of the antenna connector 42 (fig. 5) or that the second contact part 40 (shown in fig. 4), which snaps into the recessions and holds the antenna probe

50 firmly to the printed circuit board 30. This enables the antenna probe 50 to easily be placed in the antenna connector 37 or 42, and that tests can be conducted on the radio part.

- 5 The antenna probe 50 and the antenna 33 can be held and placed in the antenna connector 42 by the same rotating tool (not shown). While the antenna probe 50 is placed onto the antenna connector 42 for conducting the tests the antenna 33 can be held in another position waiting to be placed onto the antenna connector 42 after the tests have been completed. The rotating tool lifts
10 the antenna probe 50 and rotates so that the antenna 33 is placed in the mounting position and thereafter placed onto the antenna connector 42.

The invention is not limited to the above-described examples or to the drawings showing examples of an embodiment, but can be varied within the scope of the
15 appended claims.

CLAIMS

1. An antenna connector for holding an antenna in relation to a printed circuit board, where the antenna connector has means for releasable holding of the antenna onto the printed circuit board characterised in that the holding means of the antenna connector are constructed to enable later flexible removal of the antenna.
5
2. An antenna connector for holding an antenna in relation to a printed circuit board according to claim 1 characterised in that said antenna connector is soldered onto printed circuit board, and that said antenna connector is elongated including slots for contact members and a recession to overlap a corresponding recession on the antenna.
10
3. An antenna connector for holding an antenna in relation to a printed circuit board according to claim 1 characterised in that said antenna connector is soldered onto printed circuit board, and that said antenna connector is elongated including slots for contact members and that said contact members have holding parts to project into a recession on the antenna.
15
20
4. An antenna connector for holding an antenna in relation to a printed circuit board according to claim 2 or 3 characterised in that said contact members are flexible and can be bent away when the antenna is placed onto the antenna connector.
25
5. An antenna connector for holding an antenna in relation to a printed circuit board according to claim 4 characterised in that the contact members are mounted in the slots on the antenna connector, and that said contact members have a closed end part to connect to contact parts on the antenna, and that the contact members are in contact with contact pads on the printed circuit board through the slots.
30

6. An antenna connector for holding an antenna in relation to a printed circuit board according to claim 5 characterised in that the antenna connector is provided with numerous slots, wherein a required number of contact members
5 are mounted corresponding to the connection needed between the antenna and the printed circuit board, while a certain number of slots are empty if not required in that connection.

7. An antenna connector for holding an antenna in relation to a printed
10 circuit board according to claim 4 characterised in that said antenna part includes extra holding members that attach directly to the printed circuit board.

8. An antenna connector for holding an antenna in relation to a printed circuit board, where the antenna connector has means for holding the antenna
15 onto the printed circuit board characterised in that said means for holding the antenna onto the printed circuit board also can receive a testing probe without holding the probe to the printed circuit board.

9. An antenna probe for testing a communication unit using an antenna
20 connector as claimed in claim 1 characterised in that said antenna probe is received in the antenna connector and has contacts parts that fit into the holding means of the antenna connector and connects with contact members on the antenna connector, and that said probe does not include any holding means to attach to the antenna connector.

25

10. A communication unit provided with an antenna connector for holding an antenna in relation to a printed circuit board, where the antenna connector has means for releasable holding of the antenna onto the printed circuit board characterised in that the holding means of the antenna connector are
30 constructed to enable later flexible removal of the antenna.

11. A communication unit provided with an antenna connector according to claim 10 characterised in that said antenna connector is soldered onto printed circuit board, and that said antenna connector is elongated including slots for contact members and a recess to overlap a corresponding recession on the antenna.

12. A communication unit provided with an antenna connector according to claim 10 characterised in that said antenna connector is soldered onto printed circuit board, and that said antenna connector is elongated including slots for contact members and that said contact members have holding parts to project into a recession on the antenna.

13. A communication unit provided with an antenna connector according to claim 11 or 12 characterised in that said contact members are flexible and can be bent away when the antenna is placed onto the antenna connector.

14. A communication unit provided with an antenna connector according to claim 13 characterised in that the contact members are mounted in the slots on the antenna connector, and that said contact members have a closed end part to connect to contact parts on the antenna, and that the contact members are in contact with contact pads on the printed circuit board through the slots.

15. A communication unit provided with an antenna connector according to claim 14 characterised in that the antenna connector is provided with numerous slots, wherein a required number of contact members are mounted corresponding to the connection needed between the antenna and the printed circuit board, while a certain number of slots are empty if not required in that connection.

16. A communication unit provided with an antenna connector according to claim 13 characterised in that said antenna part includes extra holding members that attach directly to the printed circuit board.

5 17. A method for using an antenna connector as claimed in claim 1 for receiving an antenna probe characterised in that the antenna probe is received in the holding means of the antenna connector, and tests on a radio part on the printed circuit board are conducted, whereafter the antenna is received in the holding means of the antenna connector.

10

18. An antenna connector for holding an antenna in relation to a printed circuit board as herein before described with reference to figures 3 to 7 of the accompanying drawings.

15 19. A communication unit provided with an antenna connector as herein before described with reference to figures 1 to 7 of the accompanying drawings.

20. A method substantially as herein before described with reference to figures 3 to 7 of the accompanying drawings.

20



Application No: GB 0006418.8
Claims searched: 1-7,9-20

Examiner: Brendan Churchill
Date of search: 20 September 2000

**Patents Act 1977
Search Report under Section 17**

Databases searched:

UK Patent Office collections, including GB, EP, WO & US patent specifications, in:

UK Cl (Ed.R): H1Q (QKE)
H2E (ECBF, ECCC, EEGB, EEGKR)

Int Cl (Ed.7): H01Q
H01R

Other: Online: EPODOC, JAPIO, WPI

Documents considered to be relevant:

Category	Identity of document and relevant passage	Relevant to claims
X	EP 0902508 A2 (WHITAKER CORP) See paragraphs 0026 & 0027	1,10
A	US 5496182 (BETA PHASE)	-
A	US 5490788 (EMC)	-

X	Document indicating lack of novelty or inventive step	A	Document indicating technological background and/or state of the art.
Y	Document indicating lack of inventive step if combined with one or more other documents of same category.	P	Document published on or after the declared priority date but before the filing date of this invention.
&	Member of the same patent family	E	Patent document published on or after, but with priority date earlier than, the filing date of this application.