

(19) World Intellectual Property Organization
International Bureau



(43) International Publication Date
18 December 2008 (18.12.2008)

PCT

(10) International Publication Number
WO 2008/152601 A1

(51) International Patent Classification:
B26B 21/44 (2006.01)

(21) International Application Number:
PCT/IB2008/052328

(22) International Filing Date: 12 June 2008 (12.06.2008)

(25) Filing Language: English

(26) Publication Language: English

(30) Priority Data:
60/934,255 12 June 2007 (12.06.2007) US

(71) Applicant (for all designated States except US): **THE GILLETTE COMPANY** [US/US]; Prudential Tower Building, Boston, Massachusetts 02199 (US).

(72) Inventor; and

(75) Inventor/Applicant (for US only): **CLARKE, Sean, Peter** [GB/GB]; 10 Holy Close, Highmoor Cross, Henley-on-thames Oxfordshire RG9 5DY (GB).

(74) Common Representative: **THE GILLETTE COMPANY**; c/o Eileen L. Hughett, The Procter & Gamble Company, Winton Hill Business Center, 6250 Center Hill Avenue, Cincinnati, OH 45224 (US).

(81) Designated States (unless otherwise indicated, for every kind of national protection available): AE, AG, AL, AM, AO, AT, AU, AZ, BA, BB, BG, BH, BR, BW, BY, BZ, CA, CH, CN, CO, CR, CU, CZ, DE, DK, DM, DO, DZ, EC, EE, EG, ES, FI, GB, GD, GE, GH, GM, GT, HN, HR, HU, ID, IL, IN, IS, JP, KE, KG, KM, KN, KP, KR, KZ, LA, LC, LK, LR, LS, LT, LU, LY, MA, MD, ME, MG, MK, MN, MW, MX, MY, MZ, NA, NG, NI, NO, NZ, OM, PG, PH, PL, PT, RO, RS, RU, SC, SD, SE, SG, SK, SL, SM, SV, SY, TJ, TM, TN, TR, TT, TZ, UA, UG, US, UZ, VC, VN, ZA, ZM, ZW.

(84) Designated States (unless otherwise indicated, for every kind of regional protection available): ARIPO (BW, GH, GM, KE, LS, MW, MZ, NA, SD, SL, SZ, TZ, UG, ZM, ZW), Eurasian (AM, AZ, BY, KG, KZ, MD, RU, TJ, TM), European (AT, BE, BG, CH, CY, CZ, DE, DK, EE, ES, FI, FR, GB, GR, HR, HU, IE, IS, IT, LT, LU, LV, MC, MT, NL, NO, PL, PT, RO, SE, SI, SK, TR), OAPI (BF, BJ, CF, CG, CI, CM, GA, GN, GQ, GW, ML, MR, NE, SN, TD, TG).

Published:

- with international search report
- before the expiration of the time limit for amending the claims and to be republished in the event of receipt of amendments

(54) Title: PIVOTALLY ACTUATED PUMP DRIVEN LIQUID DISPENSING SHAVING RAZOR

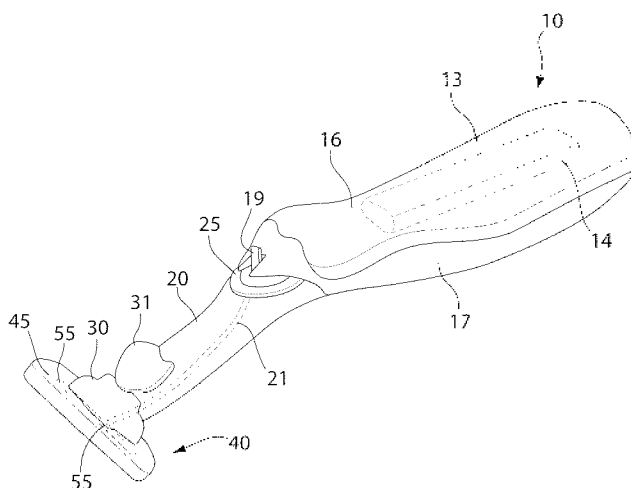

Fig. 1

(57) Abstract: A shaving razor comprising: a. a handle (10) having a proximate end (11) and a distal end (12) wherein said handle comprises a cavity (13); b. an adapter neck (20) pivotally joined to said proximate end of said handle, wherein said adapter neck further comprises 1) a pump (25) to which is joined a first feeding channel (21) extending from said cavity, wherein the pump is actuated by pivotal movement of said neck; and 2) a cartridge connection yoke (30) disposed at an opposite end of said neck from said handle; through which said feeding channel runs; and c. a razor cartridge (40) comprising a blade (45) wherein said cartridge is joined to said neck by said cartridge connection yoke and wherein said feeding channel continues to run to a disposal point (55) on said cartridge.

WO 2008/152601 A1

PIVOTALLY ACTUATED PUMP DRIVEN LIQUID DISPENSING SHAVING RAZOR

FIELD OF THE INVENTION

5 This invention relates to an automatic liquid dispensing razor that is actuated by a user's shaving motion.

BACKGROUND OF THE INVENTION

10 This invention relates to the field of wet shaving which is the process where a razor with one or more sharpened blades is moved along skin to cut hair. When a consumer engages in the wet shaving experience, it is typical to apply a skin preparation, e.g., shaving soap, shaving cream, shaving gel, skin conditioning foam, etc., via a brush or manual application prior to movement of the razor along the skin's surface. Most consumers find this type of preparation to be rather inconvenient because of the need for multiple shaving products, e.g., a wet shaving
15 razor and a skin preparation product, as well as the undesirable necessity for multiple application steps during the wet shaving process. This multi-step process also results in an overall extended shaving experience which most consumers do not prefer given typical morning hygiene routines. In certain instances, however, it may still be desirable sometimes to apply fluids of other kinds to the skin before, during, or after shaving to promote ancillary skin and/or hair benefits.

20 In the past, there have been a number of wet shaving product configurations that include a system for conveying a shaving preparation, e.g. a lubricating fluid, from a reservoir incorporated in the razor structure in the form of a hollowed out razor handle or even an aerosol can that acts as a razor handle, to a dispensing location near the head of the razor. A number of more recent wet shaving razors have cartridges that are movably mounted, in particular pivotable, relative to
25 the handle structures on which they are mounted either permanently, in the case of disposable safety razors intended to be discarded when the blade or blades have become dulled, or detachably to allow replacement of the blade unit on a reusable handle structure. An exemplary razor of this sort is disclosed in US Patent 6789321 issued to Simms on September 14, 2004 or US Patent 7127817 issued to Orloff et al. on October 31, 2006. Many of these types of razors
30 that are capable of conveying a liquid to the skin surface are unfortunately plagued by a number of problems. For instance, the innerworkings of the razors tend to be cost prohibitive from a large scale manufacturing standpoint. Additionally, there are safety and performance issues that

are constantly experience due to microbial growth with the reservoir due to the continued exposure of a portion of the remaining liquid to air. This exposure of the liquid to air may oftentimes result in clogging of the razor's innerworkings by the liquid resulting in a nonperforming shaving product.

5

SUMMARY OF THE INVENTION

The present invention relates to a shaving razor comprising:

- a. a handle having a proximate end and a distal end wherein said handle comprises a cavity;
- b. an adapter neck pivotally joined to said proximate end of said handle, wherein said
10 adapter neck further comprises
 - 1) a pump to which is joined a first feeding channel extending from said cavity, wherein the pump is actuated by pivotal movement of said neck; and
 - 2) a cartridge connection yoke disposed at an opposite end of said neck from said handle; through which said feeding channel runs; and
- 15 c. a razor cartridge comprising a blade wherein said cartridge is joined to said neck by said cartridge connection yoke and wherein said feeding channel continues to run to a disposal point on said cartridge.

In another embodiment, the present invention relates to a shaving implement suited for carrying a replaceable razor cartridge, said razor comprising:

- 20 a. a handle having a proximate end and a distal end wherein said handle comprises a cavity;
- b. an adapter neck pivotally joined to said proximate end of said handle, wherein said adapter neck further comprises
 - 1) a pump to which is joined a first feeding channel that extends from said cavity, wherein the pump is actuated by pivotal movement of said neck; and
 - 25 2) a cartridge connection yoke disposed at an opposite end of said neck from said handle through which said first feeding channel runs and terminates at a connectable endpoint.

BRIEF DESCRIPTION OF THE DRAWINGS

- 30 FIG. 1 shows a top perspective view of a razor of the present invention.
- FIG. 2 shows a bottom perspective view of the cartridge of the razor of FIG. 1.
- FIG. 3 shows an exploded perspective view of the razor of FIG. 1.

DETAILED DESCRIPTION OF THE INVENTION

The shaving razor shown in FIGS. 1 and 3 includes a handle 10 that includes a proximal end 11 and a distal end 12 and the handle 10 includes a cavity 13. Attached or joined pivotally to the handle 10 at the proximal end is an adapter neck 20. The adapter neck 20 comprises a pump 25 from which extends a first feeding channel 21 to the cavity 13. The pump is actuated by pivotal action of the neck 20 and moves a liquid from the cavity 13 through the first feeding channel 21. The neck further includes a cartridge connection yoke 30. This yoke 30 is disposed at an opposite end of the neck 20 from the handle 10. The handle 10 may comprise an upper portion 16 and a lower portion 17 that are intended for connectable joiner to form the handle and thereby form the external boundaries of the cavity 13. FIG. 3 additionally shows that the cavity may contain a sachet 14 useful for storing a treatment composition to be dispensed during shaving as well as a gripping element on the handle 10. This gripping element may be placed on the upper portion, lower portion, or both to aid a consumer's grip of the razor during use.

The first feeding channel 21 of FIGS. 1 and 3 runs through the neck 20 and terminates at a disposal point 55 on a razor cartridge 40. The cartridge 40 comprises a blade 45 and is joined to the adapter neck 20 by the cartridge connection yoke 30.

The yoke 30 comprises at least one arm 35 that extends to connect to a razor cartridge 40. By way of an ejector button 31, the yoke 30 may releasably engage the razor cartridge 40 which further includes one or more blades 45. The first feeding channel 21 leads from the pump 25 to a disposal point 55 within the cartridge 40 to allow for disbursement of a fluid to a user's skin during shaving. In a certain embodiment the disposal point 55 is a manifold. The manifold may be capable of delivering the fluid at a single point or multiple, evenly or unevenly distributed points along the length of the one or more blades 45.

In FIG. 2, the one or more razor blades 45 are sandwiched between a guard 60 and a lubricating strip 65. The guard is useful for stretching the skin's surface immediately prior to engagement with the blade or a first blade (when more than one blade is present). This guard may typically comprise elastomeric material to allow for an engagement that is comfortable to a user. The lubricating strip, on the other hand, provides an additional treatment to the skin after contact between the fluid and the skin has occurred. The lubricating strip may contain the same or additional skin ingredients to those that are present in the fluid. Suitable lubricating strips are disclosed in US Patent 7069658 issued to Tseng et al. on July 4, 2006, US Patent 6944952 issued

on September 20, 2005, US Patent 6594904 issued on July 22, 2003, US Patent 6182365 issued to Tseng et al. on February 6, 2001, US Design Patent D424745 issued to Tseng et al. on May 9, 2000, and US Patent 6185822 issued to Tseng et al. on February 13, 2001, and US Patent 6298558 issued to Tseng on October 9, 2001, and US Patent 5113585 issued to Rogers et al. on
5 May 19, 1992.

A spreading medium 46 may be placed below, above, or integral to the guard within the razor cartridge. In the embodiment of FIG. 2, the spreading medium is positioned below the blade. The spreading medium may comprise a porous material selected from the group consisting of polyurethane, polyethylene, and combinations thereof. For instance, e.g., a sintered
10 polyethylene material which is commercially available from Porex Technologies GmbH is suited for use herein. This porous material may be either hydrophilic or hydrophobic depending on the polarity of the fluid to be dispensed by the razor. Likewise, the average pore size of the material may range from about 1 micron to about 500 microns, from about 5 microns to about 300 microns, from about 5 microns to about 200 microns, from about 10 microns to about 150
15 microns, from about 10 microns to about 100 microns, from about 20 microns to about 60 microns, and from any specific lower limit to any specific upper limit within the broadest range mentioned herein. The spreading medium may be used in any shape or size that snugly fits in the razor cartridge in advance of the blade or blades. Also, in certain embodiments the spreading medium may extend substantially along a full length of the cartridge as shown in FIG. 2. In
20 others, the medium may extend across only a central portion of the cartridge, either above or below the guard and/or blades.

In order to preserve the utility of the spreading medium, it is envisioned that a cover may be supplied prior to sale to the consumer for the medium to prevent inadvertent dehydration of the fluid to be dispensed from the razor. In a certain embodiment, the pump of the razor may be
25 primed to pre-wet the spreading medium with the fluid or treatment composition prior to consumer use. Alternatively, such a cover could also be used by the end user to prevent dehydration of the fluid even after the initial priming of the pump when the shaving razor is used by the user for the first time.

FIG. 2 also shows clips 48 which are useful for retaining and maintaining the stability of
30 the blade before, during, and after use of the razor.

The adapter neck may be either permanently or removably joined to the handle. In the case where the adapter head is removable, the cavity may also be removably accessible or just

accessible at the point of joinder between the handle and the neck. In the instance where it is desired that the entire razor be deemed disposable, e.g., suitable for five or fewer uses, the handle and adapter neck may be integrally formed with the cavity being filled with a fluid during manufacture or soon thereafter or at the very least prior to purchase by a user and not being
5 capable of easy refilling by the user.

In a certain embodiment as shown in FIGS. 1 and 3, the pump 25 included in the adapter neck may be a pump that included stacked components and particularly a movable wall 26 that acts to activate the flow of fluid from the cavity through a first feeding channel and to the disposal point. A pump suitable for use in the present invention is disclosed in US Patent
10 5993180 issued to Westerhof on November 30, 1999. In particular, this well-suited pump includes a pump chamber bounded by the movable wall, an inlet channel and an outlet channel, both of which are connected to the pump chamber, an inlet valve for closing the inlet channel, and an outlet valve for closing the outlet channel. The movable wall 26 of the pump may take a number of forms. For instance, one movable wall embodiment may comprise a rigid topside that
15 moves in the z-direction in response to a force acted upon the rigid topside that in turn causes non-rigid side walls of the pump to compress to move a fluid through the razor. In another embodiment, the topside surface of the wall may be flexible such that the mere application of force to the flexible topside results in a “movable” wall that gives in response to such force. In most instances, the pump may be actuated by the defined and restricted (via a limited rotation of
20 a pivotal axis of the neck) movement by a shaver’s stroke of the shaving surface. This permits the user to easily control the amount of fluid that is dispensed during the shaving experience. Because the valves of the pump are automatically opened when force is exerted on the wall of the pump of the neck by shaving a skin surface. It is also possible to place one or more movable walls of the pump on an upper surface or lower surface of the razor depending on a the
25 configuration of the shaving product relative to whether the wall of the pump to which force or pressure is applied is on a top side or under side of the adapter neck.

With respect to the handle, it is the intention of the present invention that the razor be actuated and liquid dispensed as a result of the user’s shaving motion. As part and parcel of such a user driven capability, the razor may additionally comprise an adjustable flow rate switch 19.
30 In certain embodiments, the switch 19 may be disposed on an upper portion or lower portion of the handle. Such an adjustable flow rate 19 switch may allow the user to increase or decrease the amount of fluid that is dispensed per shaving motion or stroke based on his/her needs, i.e.,

hair and/or skin texture. Moreover, this same switch may also serve the function of preventing the pivotal movement of the adapter neck when a force is exerted by a user when a skin surface is shaved. In this instance, there would be no dispensing of a fluid to the skin surface during shaving or at any other time until such a switch is moved from this “closed” to an “open” position. This may be a desirable option when a user has adequately lubricated the skin surface to be shaved and no longer wishes his/her stroke during shaving to dispense any further fluids. The switch may take various forms, e.g., a two position, flip-type or rotary (dial) switch useful for a “closed” and an “open” position or a three or more position, flip-type or rotary (dial) switch which further includes at least one intermediate “open” position in advance of the full “open” position.

There are a number of fluids that may be useful in the present razor. For instance, shaving gels, shaving foams, shaving lotions, skin treatment compositions, conditioning aids, etc. may be used to prepare the skin’s surface prior to the engagement of the blade with the skin. Additionally, such materials may comprise benefit agents suitable for skin and/or hair that may be useful for a number of different desirable effects including exfoliation, cooling effects, cleansing, moisturization, warming or thermogenic effects, conditioning, and the like. Suitable benefit agents for skin and/or hair for inclusion into the fluid of the razor are disclosed in US Patent 6789321. For instance, suitable agents include but are not limited to shaving soaps, lubricants, skin conditioners, skin moisturizers, hair softeners, hair conditioners, fragrances, skin cleansers, bacterial or medical lotions, blood coagulants, anti-inflammatories, astringents, and combinations thereof. In certain embodiments, the fluid may be contained in a sachet, either disposable or reusable, that is further contained within the cavity of the handle. The sachet may comprise one or more walls which may be rigid, semi-rigid, collapsible, or a combination thereof.

The razor cartridge of the present invention may be releasably engaged from the cartridge yoke and such elements are disclosed in US Patents D533684 S, 5918369, and 7168173 B2. This disengagement of these two components allows for replacement of razor cartridges as the continued use of such cartridges causes blade dulling. Thus, such cartridges are replaceable and disposable at will by the user. The yoke further comprises one or more arms that extend from the yoke and provide pivotal support of the yoke against the cartridge. The yoke may additionally comprise an ejection button to disengage the yoke from the cartridge to allow for simple replacement of the cartridge when blades have been dulled due to wear.

Another embodiment of the present invention merely relates to an implement that may be used in conjunction with a razor cartridge. This implement is suited for carrying a replaceable razor cartridge and comprises a handle having a proximate end and a distal end wherein the handle comprises a cavity; an adapter neck pivotally joined to the proximate end of the handle, wherein the adapter neck further comprises 1) a pump to which is joined a first feeding channel that extends from said cavity, wherein the pump is actuated by pivotal movement of said neck; and 2) a cartridge connection yoke disposed at an opposite end of the neck from the handle through which the first feeding channel runs and terminates at a connectable endpoint.

The dimensions and values disclosed herein are not to be understood as being strictly limited to the exact numerical values recited. Instead, unless otherwise specified, each such dimension is intended to mean both the recited value and a functionally equivalent range surrounding that value. For example, a dimension disclosed as “40 mm” is intended to mean “about 40 mm”.

All documents cited in the Detailed Description of the Invention are, in relevant part, incorporated herein by reference; the citation of any document is not to be construed as an admission that it is prior art with respect to the present invention. To the extent that any meaning or definition of a term in this document conflicts with any meaning or definition of the same term in a document incorporated by reference, the meaning or definition assigned to that term in this document shall govern.

While particular embodiments of the present invention have been illustrated and described, it would be obvious to those skilled in the art that various other changes and modifications can be made without departing from the spirit and scope of the invention. It is therefore intended to cover in the appended claims all such changes and modifications that are within the scope of this invention.

CLAIMS

What is claimed is:

1. A shaving razor characterized in that said razor comprises:
 - a. a handle having a proximate end and a distal end wherein said handle comprises a cavity;
 - b. an adapter neck pivotally joined to said proximate end of said handle, wherein said adapter neck further comprises
 - 1) a pump to which is joined a first feeding channel extending from said cavity, wherein the pump is actuated by pivotal movement of said neck; and
 - 2) a cartridge connection yoke disposed at an opposite end of said neck from said handle; through which said feeding channel runs; and
 - c. a razor cartridge comprising a blade wherein said cartridge is joined to said neck by said cartridge connection yoke and wherein said feeding channel continues to run to a disposal point on said cartridge.
2. The shaving razor of claim 1 wherein the cavity is suited to accommodate a sachet of a treatment composition.
3. The shaving razor of claim 1 wherein the pump comprises a movable wall upon which force is acted upon to move a treatment composition through the feeding channel to the disposal point.
4. The shaving razor of claim 3 wherein said force is exerted on the wall of the pump of the neck by shaving a skin surface.
5. The shaving razor of claim 1 wherein the pump comprises a rigid wall upon which force is acted upon to cause the movement of non-rigid sidewalls of said pump to move a treatment composition through the feeding channel to the disposal point.
6. The shaving razor of claim 1 wherein said handle comprises an adjustable flow rate switch.

7. The shaving razor of claim 6 wherein said adjustable flow rate switch is disposed on said handle in a location selected from the group consisting of an upper portion of said handle or a lower portion of said handle.
8. The shaving razor of claim 6 wherein said adjustable flow rate switch prevents pivotal movement of the neck when a force is exerted by shaving a skin surface.
9. The shaving razor of claim 1 wherein a skin treatment composition is fed from a sachet within said cavity through said feeding channel to said disposal point.
10. The shaving razor of claim 9 wherein said disposal point runs along a length of said blade.
11. The shaving razor of claim 10 wherein said treatment composition comprises a benefit agent suitable for skin and/or hair.
12. The shaving razor of claim 1 wherein said cartridge further comprises a spreading medium.
13. The shaving razor of claim 12 wherein said spreading medium is primed with a treatment composition prior to consumer use.
14. The shaving razor of claim 1 wherein said cartridge connection yoke comprises an ejection button for releasably engaging said cartridge.

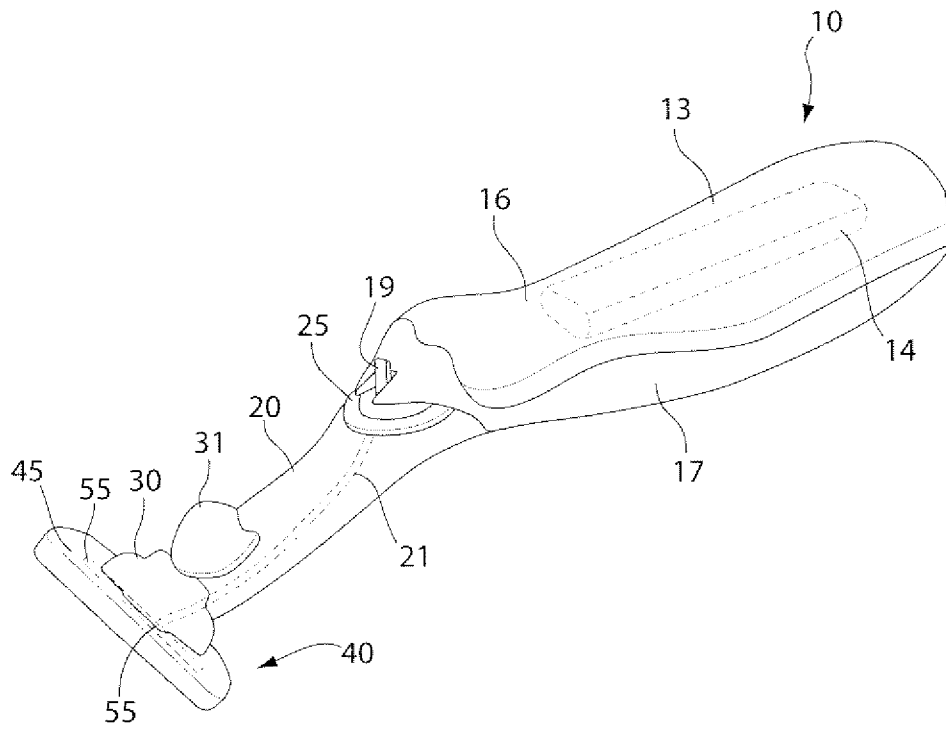

Fig. 1

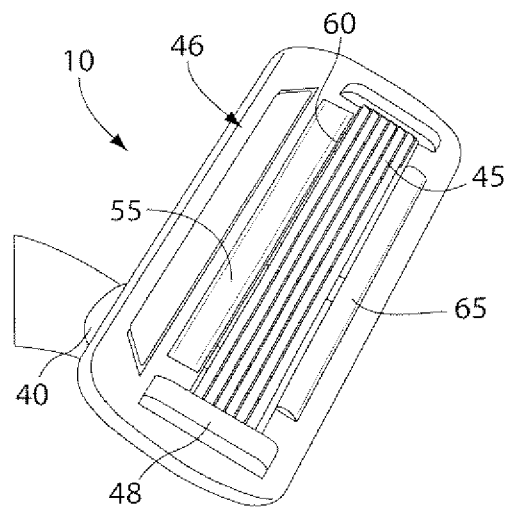

Fig. 2

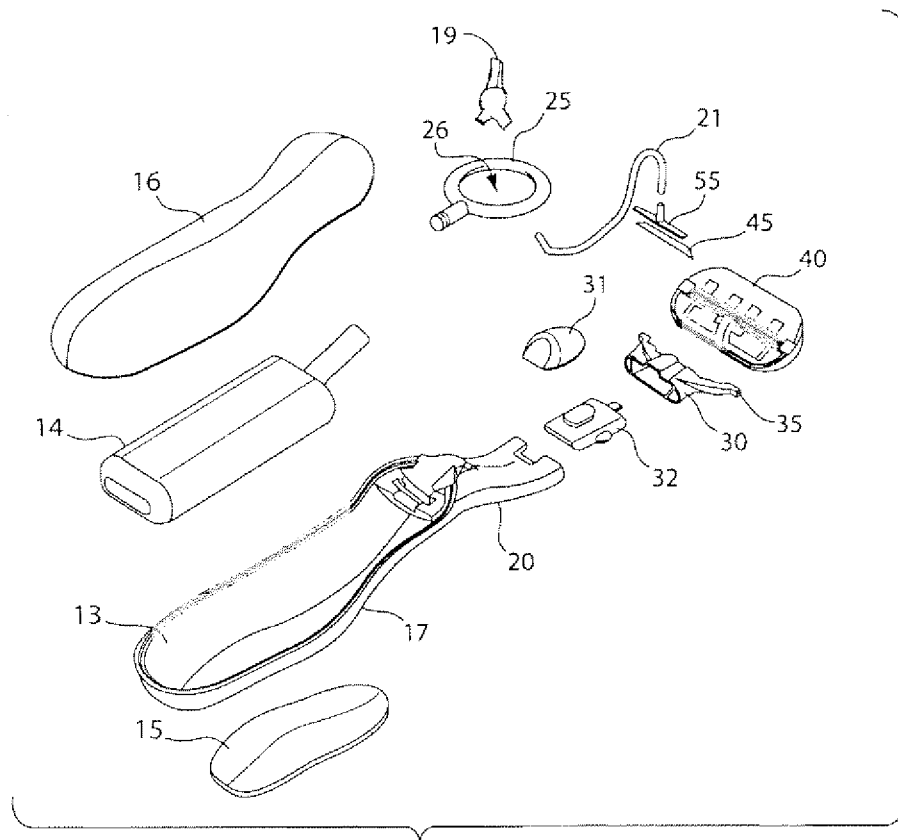

Fig. 3

INTERNATIONAL SEARCH REPORT

International application No
PCT/IB2008/052328

A. CLASSIFICATION OF SUBJECT MATTER
INV. B26B21/44

According to International Patent Classification (IPC) or to both national classification and IPC

B. FIELDS SEARCHED

Minimum documentation searched (classification system followed by classification symbols)
B26B

Documentation searched other than minimum documentation to the extent that such documents are included in the fields searched

Electronic data base consulted during the international search (name of data base and, where practical, search terms used)
EPO-Internal

C. DOCUMENTS CONSIDERED TO BE RELEVANT

Category*	Citation of document, with indication, where appropriate, of the relevant passages	Relevant to claim No.
A	US 2005/126008 A1 (PENNELLA ANDREW [US] ET AL) 16 June 2005 (2005-06-16) paragraphs [0016] - [0023]; figures 1-3	1
A	WO 00/47374 A (GILLETTE CO [US]; SIMMS GRAHAM JOHN [GB]) 17 August 2000 (2000-08-17) page 5, paragraph 2 - page 6, paragraph 2; figures 1,4,5	1
A	EP 0 463 992 A (RONDA S A [CH] KAI IND CO LTD [JP]) 2 January 1992 (1992-01-02) page 5, lines 14-26; figures 1.4,4a	1
A	US 2005/120559 A1 (BRESSLER PETER [US] ET AL) 9 June 2005 (2005-06-09) paragraphs [0017] - [0020]; figures 2,3	1
	-/--	

Further documents are listed in the continuation of Box C. See patent family annex.

- * Special categories of cited documents :
- *A* document defining the general state of the art which is not considered to be of particular relevance
 - *E* earlier document but published on or after the international filing date
 - *L* document which may throw doubts on priority claim(s) or which is cited to establish the publication date of another citation or other special reason (as specified)
 - *O* document referring to an oral disclosure, use, exhibition or other means
 - *P* document published prior to the international filing date but later than the priority date claimed
 - *T* later document published after the international filing date or priority date and not in conflict with the application but cited to understand the principle or theory underlying the invention
 - *X* document of particular relevance; the claimed invention cannot be considered novel or cannot be considered to involve an inventive step when the document is taken alone
 - *Y* document of particular relevance; the claimed invention cannot be considered to involve an inventive step when the document is combined with one or more other such documents, such combination being obvious to a person skilled in the art.
 - *&* document member of the same patent family

Date of the actual completion of the international search 8 October 2008	Date of mailing of the international search report 21/10/2008
Name and mailing address of the ISA/ European Patent Office, P.B. 5618 Patentlaan 2 NL - 2260 HV Rijswijk Tel. (+31-70) 340-2040, Fax: (+31-70) 340-3016	Authorized officer Rattenberger, B

INTERNATIONAL SEARCH REPORT

International application No
PCT/IB2008/052328

C(Continuation). DOCUMENTS CONSIDERED TO BE RELEVANT		
Category*	Citation of document, with indication, where appropriate, of the relevant passages	Relevant to claim No.
A	US 2004/074097 A1 (GUIMONT RAYMOND [US] ET AL) 22 April 2004 (2004-04-22) paragraphs [0028] - [0034], [0054]; figures 2,4	1
A	GB 2 417 007 A (GILLETTE CO [US]) 15 February 2006 (2006-02-15) paragraphs [0019] - [0021]; figures 1,2	1

INTERNATIONAL SEARCH REPORT

Information on patent family members

International application No PCT/IB2008/052328

Patent document cited in search report	Publication date	Patent family member(s)	Publication date
US 2005126008 A1	16-06-2005	AU 2004299506 A1	30-06-2005
		EP 1697097 A1	06-09-2006
		JP 2007514483 T	07-06-2007
		WO 2005058560 A1	30-06-2005
WO 0047374 A	17-08-2000	AU 2454600 A	29-08-2000
		DE 60001055 D1	30-01-2003
		DE 60001055 T2	17-07-2003
		EP 1152872 A1	14-11-2001
		ES 2184694 T3	16-04-2003
		US 2002023351 A1	28-02-2002
EP 0463992 A	02-01-1992	DE 59101190 D1	21-04-1994
		DK 463992 T3	05-04-1994
		ES 2053309 T3	16-07-1994
		JP 4231909 A	20-08-1992
		US 5168628 A	08-12-1992
US 2005120559 A1	09-06-2005	AU 2004297186 A1	23-06-2005
		EP 1691956 A1	23-08-2006
		JP 2007512912 T	24-05-2007
		WO 2005056252 A1	23-06-2005
US 2004074097 A1	22-04-2004	NONE	
GB 2417007 A	15-02-2006	AU 2005271069 A1	16-02-2006
		CA 2576019 A1	16-02-2006
		CN 101005930 A	25-07-2007
		EP 1793970 A1	13-06-2007
		WO 2006016159 A1	16-02-2006
		JP 2008508975 T	27-03-2008