

(No Model.)

F. C. DAY.
VEHICLE BRAKE.

No. 312,436.

Patented Feb. 17, 1885.

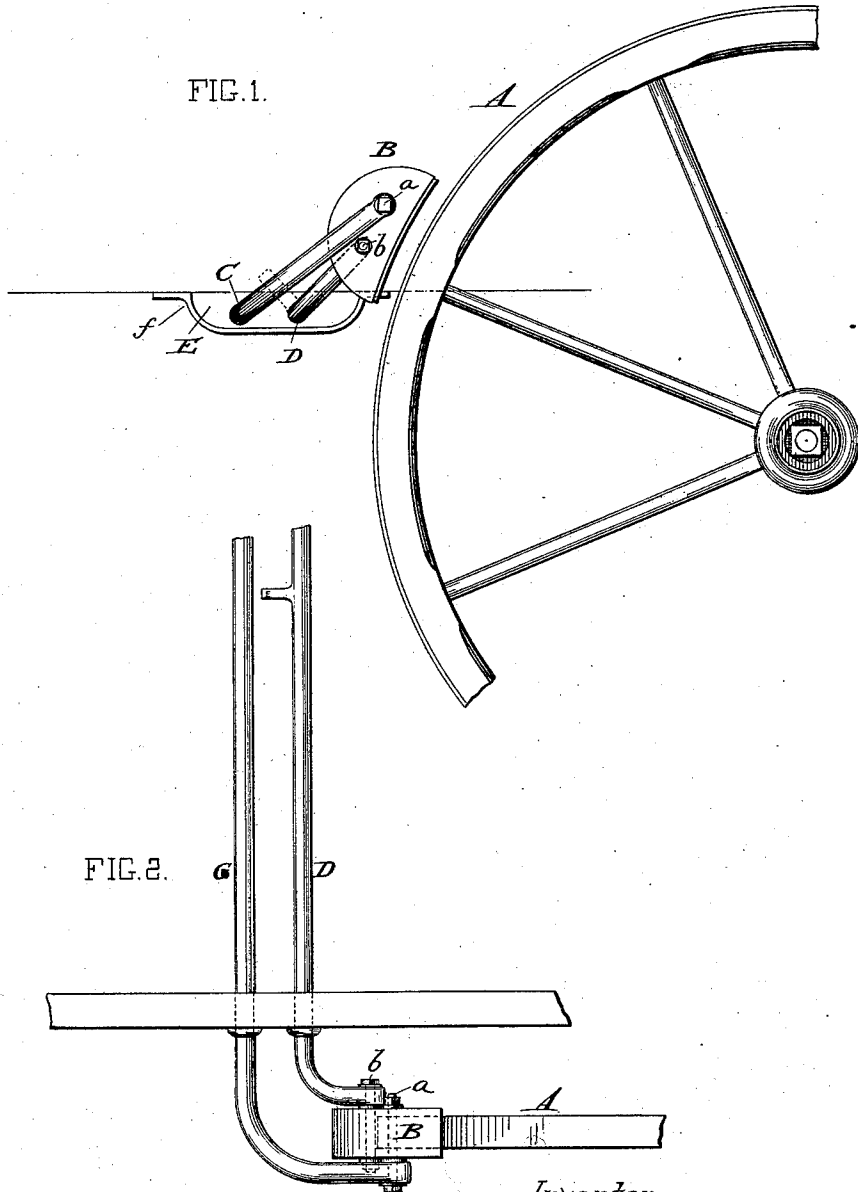

Witnesses.

J. L. Brown
H. W. Smith

Inventor:

F. C. Day.
By P. T. Dodge.
Attorney.

UNITED STATES PATENT OFFICE.

FRANK C. DAY, OF SCRANTON, PENNSYLVANIA.

VEHICLE-BRAKE.

SPECIFICATION forming part of Letters Patent No. 312,436, dated February 17, 1885.

Application filed October 1, 1884. (No model)

To all whom it may concern:

Be it known that I, FRANK C. DAY, of Scranton, in the county of Lackawanna and State of Pennsylvania, have invented certain Improvements in Brakes for Wagons, Cars, &c., of which the following is a specification.

This invention relates to an improved manner of supporting and operating brake shoes or rubbers, whereby the shoe may be moved directly to and from the face of the wheel and applied thereto in an efficient manner.

To this end the invention consists, essentially, in pivoting the shoe to the crank arms at the extremities of two parallel rock-shafts, to one of which the power is applied for moving the shoe into and out of an operative position.

My improvement is applicable to carriages, wagons, cars, and other wheeled vehicles in general.

Referring to the accompanying drawings, Figure 1 represents a side elevation of part of a wagon-wheel and so much of the brake mechanism as is necessary to a perfect understanding of my invention. Fig. 2 is a top plan view of the same.

A represents the wheel, and B the shoe or rubber, the face of which should correspond in form with the face of the wheel. The shoe is connected, as shown, by horizontal bolts or pivots *a* and *b*, to the cranked ends of two rock-shafts, C and D, which extend transversely across the body or frame of the vehicle, and which will give support at the opposite end in like manner to the other shoe. The shafts may be supported in any suitable manner. In the case of a wagon I recommend that they be seated in a wooden block, E, secured to the under side of the body by means

of a metal strap, F, as represented in the 40 drawings.

It will be perceived that the arm of the lower shaft is shorter than that of the upper, and that it is attached below the end of the shoe, so that when a forward rotation is imparted to the shaft D the block will be carried forward directly and squarely against the face of the wheel.

The shaft may be operated by mechanism of any suitable character, the present invention having no reference thereto.

It will be observed that owing to the position of the rock-shafts they apply the block with increasing force as it is urged against the wheel. It will also be observed that the friction of the wheel, applied in a forward or downward direction, assists in holding the block in contact therewith.

Having thus described my invention, what I claim is—

1. In a wagon-brake, the combination of two parallel rock-shafts having rigid crank-arms on their ends and a brake-shoe mounted directly upon said arms, substantially as described and shown.

2. In combination with the brake-shoe, the rock-shaft C, having the crank-arm pivoted to the upper end of the shoe, and the rock-shaft D, having a relatively shorter arm pivoted to the lower end of the shoe.

In testimony whereof I hereunto set my hand, this 11th day of August, 1884, in the presence of two attesting witnesses.

FRANK C. DAY.

Witnesses:

FRED W. GÜNSTER,
F. L. BROWN.