

(21) Application No: **1510193.4**
 (22) Date of Filing: **11.06.2015**
 (30) Priority Data:
 (31) **14305086** (32) **16.06.2014** (33) **US**

(51) INT CL:
B65D 47/08 (2006.01)

(56) Documents Cited:
WO 2014/201645 A1 **US 6702109 B1**
US 4821899 A **US 4513888 A**

(71) Applicant(s):
Blackhawk Molding Co., Inc.
120 Interstate Road, Addison, Illinois 60010,
United States of America

(58) Field of Search:
 INT CL **B65D**
 Other: **EPODOC, WPI**

(72) Inventor(s):
Jeffrey Davis
Douglas Hidding

(74) Agent and/or Address for Service:
Withers & Rogers LLP
4 More London Riverside, LONDON, SE1 2AU,
United Kingdom

(54) Title of the Invention: **Closure with hinged lid**
 Abstract Title: **Closure having a hinge with hook-shaped post support**

(57) A closure for a container of the kind use to deliver milk and juice. The closure is a two-piece construction having a lid 14 and a base 12 with an opening. The base has a skirt and at least one internal thread formed on an inside surface of the skirt. The lid has a depending plug shaped to fit at least partially into the opening of the base. The closure has a hinge that is formed of a post 56 connected by a tab 50 to the lid, and hinge supports extending upwardly from the closure's base. The hinge supports include a hook 32 and a bridge 30. The hook may have a bevelled portion, and may have a buttress 34. The post may have axially-extending external ribs or splines. Another aspect of the invention has the hinge disposed substantially within a space defined by the plane of the upper surface of the lid, and a cylinder corresponding to the outermost portion of the skirt.

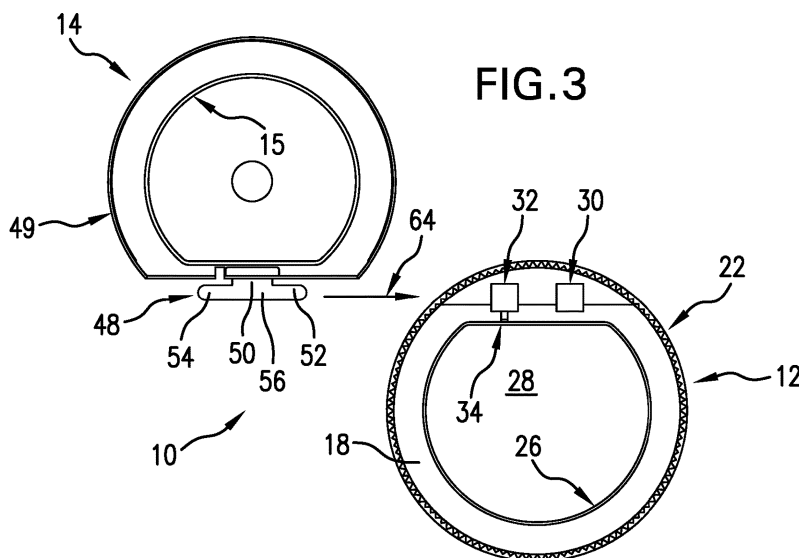

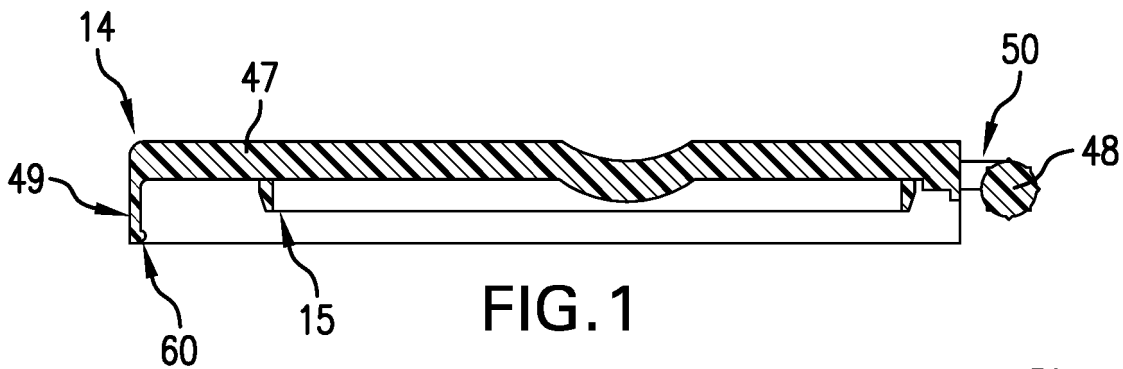

FIG. 1

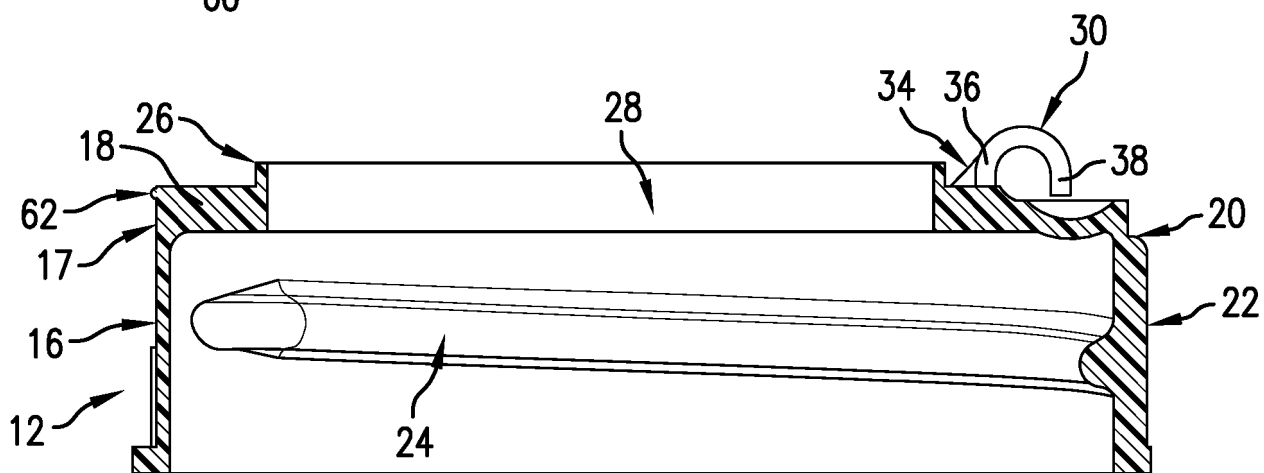

FIG. 2

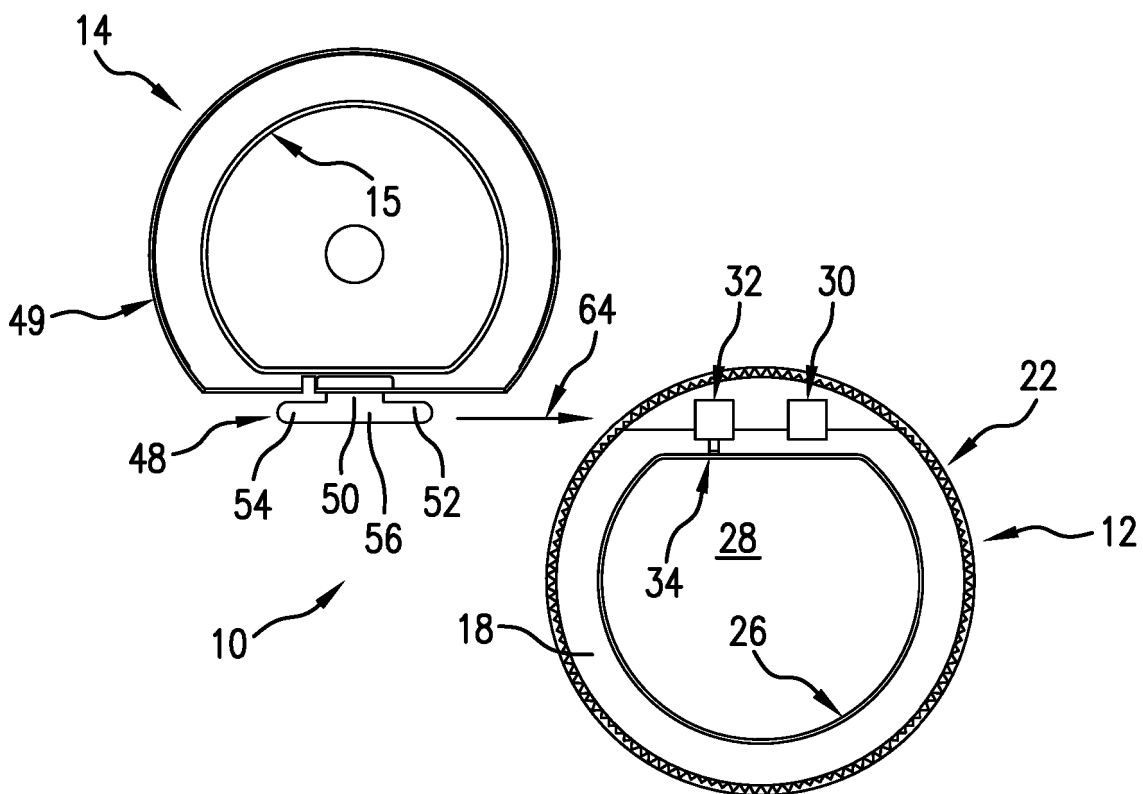

FIG. 3

16 06 15

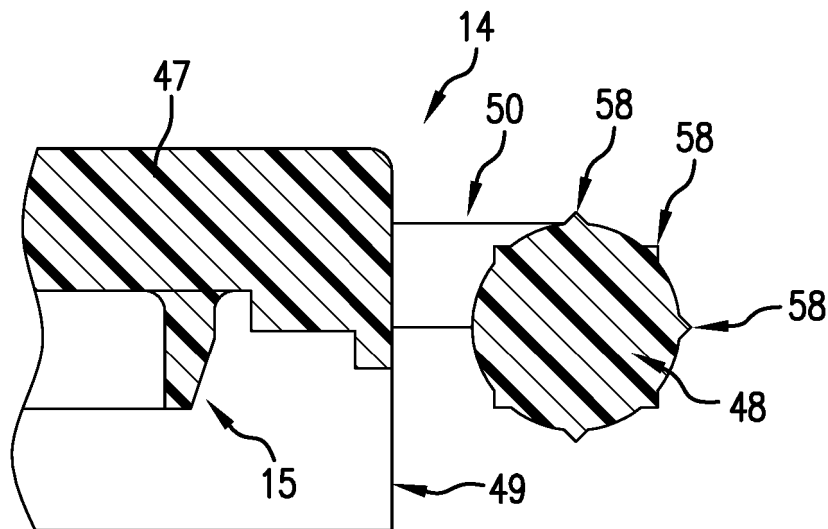

FIG. 4

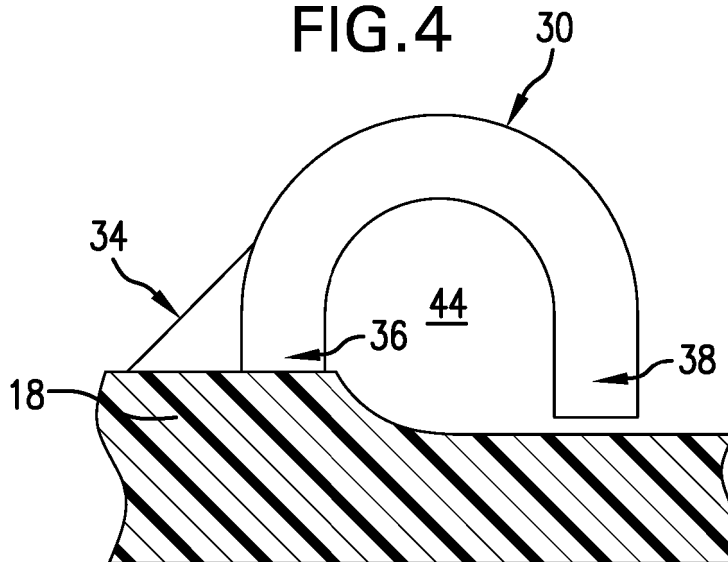

FIG. 5

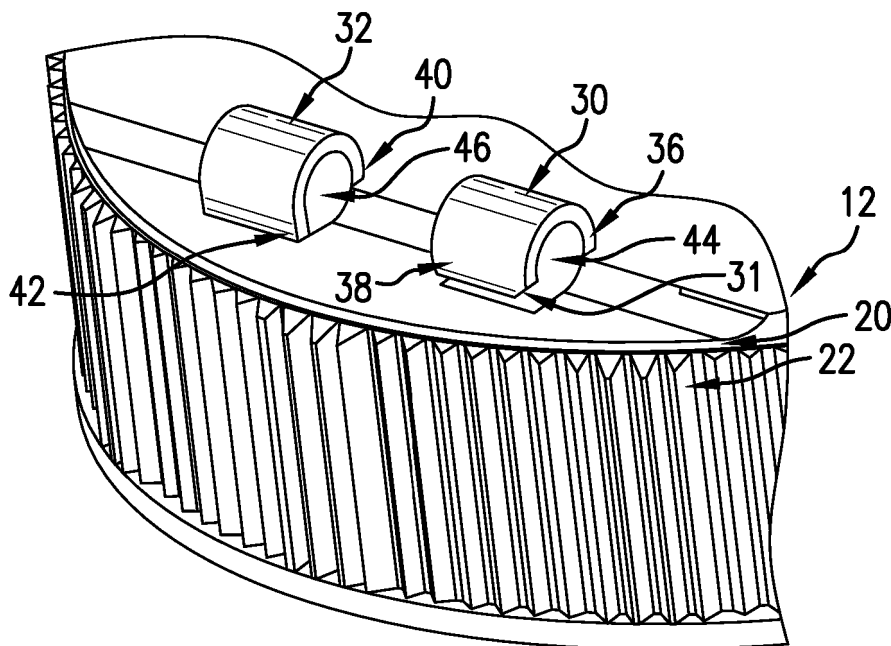

FIG. 6

16 06 15

16 06 15

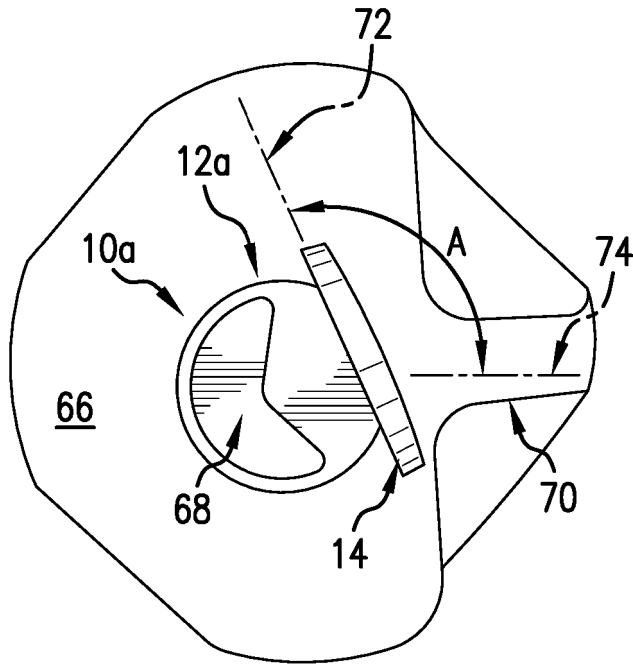

FIG. 7

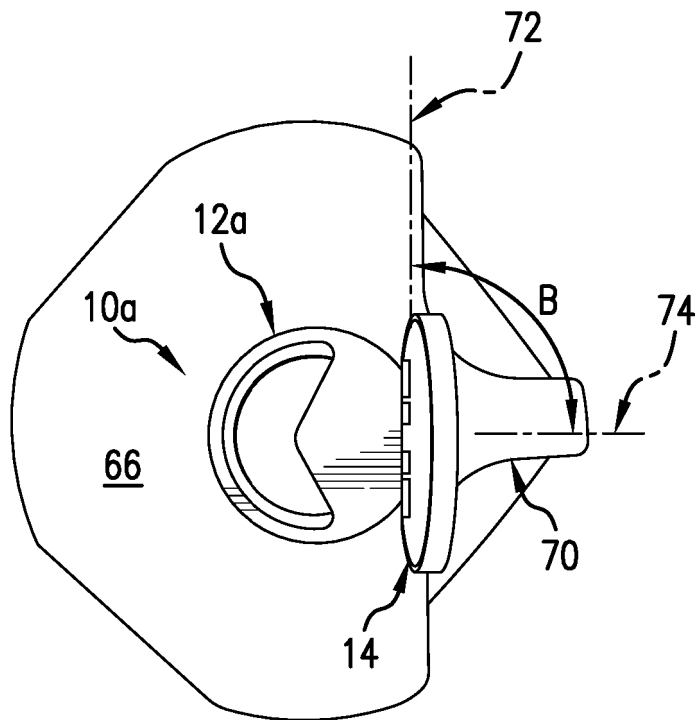

FIG. 8

TITLE:

CLOSURE WITH HINGED LID

Background and Summary

The closures shown and described are for use with containers for beverages, such as milk, other dairy products and juice. Containers that are blow-molded by bottlers of dairy and juice drinks closures have typically been used with simple threaded or push-on closures with flat integral lids. The closures require some form of tamper indicating feature, a popular version of which is the use of a foil liner placed on the interior of the closure. The foil liner is subsequently sealed against and connected to the neck of the container at an induction sealing station after the container is filled and after the closure is installed on the container.

Closures for bottled water (e.g., 28 mm diameter) have in recent years been supplied with a wide variety of flip top designs in which an easily openable and closeable lid is carried by a threaded closure base, and such flip-top features are popular. Flip top features, however, have not typically been included on larger diameter closures (e.g., 38 mm) of the kind used on blow-molded gallon, half-gallon and quart sized containers, perhaps because of cost concerns and/or the difficulty of designing a flip-top feature that will not cause problems when run through existing feeding equipment that is in place in bottling facilities. Some relatively large closures have been designed with integral hinges, known as a "butterfly" hinge, an example of which is shown in US 5,588,546. Such hinges are a form of living hinge, and tend to break easily.

The closures described herein have a two-piece design that includes a flip top feature, and yet they are compatible with existing feeding equipment used in numerous dairies and other beverage bottling operations. The closures described herein also have the advantage to a closure supplier of allowing a single or standard color base component to be used with lids of different colors. This allows

a closure supplier to quickly and efficiently respond to orders for closures, because instead of having to mold closures to fill an order for a particular colored closure, the supplier can simply assembly lids of a particular color lid to a standard base.

Brief Descriptions of the Drawings

Figure 1 is a cross sectional view of a lid of the closure of the present invention;

Figure 2 is cross-sectional of the base of the closure of the present invention;

Figure 3 is a schematic plan view showing the manner in which the lid of the closure is assembled to the base of the closure;

Figure 4 is an enlarged cross-sectional the lid of figure one showing a portion of the change used to connect the lid of Figure 1 to the base of Figure 2;

Figure 5 is an enlarged partially cross-sectional view a portion of the base showing of the structures by which the lid is joined to the base;

Figure 6 is a partial perspective view of the structures of the base that are used to connect the lid to the base.

Figures 7 and 8 show an alternative cap on a bottle with and without a foil liner in place, respectively.

Detailed Description

Figures 1 depicts the upper one of a two-component closure, i.e., the lid 14 having a cover 47 and a lid skirt 49. Extending rearwardly from the cover 47 is a post 48 joined to the lid by tab 50. A downwardly depending plug 15 extends from the underside of the cover 47. On the portion of the lid skirt 49, at a location which is diametrically opposite the location of the post 48, a small latch bead 60 extends inwardly from the lower end of the lid skirt 49.

Figure 2 shows the base 12, which together with the lid 14 of Figure 1, forms a closure 10 as described herein. The base 12 includes a skirt 16 having a single internal thread 24 integrally formed on the inside surface of the skirt 16. A single thread 24 is preferable, because it ensures that the closure, when installed on a container having handle, aligns correctly, such that the lid 14 opens in a direction directly toward the handle. See the discussion of Figures 7 and 8 below. This allows the contents of the container to be dispensed without interfering with the lid 14. A flange 18 extends inwardly from the upper end of the skirt 16, and the flange 18 surrounds an opening 28 formed in the central portion of the base 12. An upwardly extending sealing lip 26 is formed on the inside upper edge of the flange 18. The lip 26 is intended to engage and sealingly abut the plug 15 formed on the underside of the cover 47 of the lid 14.

Figure 3 is a schematic plan view showing the manner by which a lid 14 is assembled into engagement with a base 12. As shown in Figures 5 and 6, the base includes support structures for the post 48 in the form of a hook 30 and a bridge 32. When the lid 14 and base 12 are arranged as shown in Figure 3 and moved relative to each other in the direction of arrow 64, the rounded (and slightly tapered) leading end 52 of the post 48 is inserted into the tunnel section 44 formed by the hook 30. Upon further movement of the post 48 in the direction of the arrow 64 into the first tunnel section 44 the beveled leading edge 31 (Figure 6) on the outwardly facing edge of the free distal end 38 of the hook 30 prevents interference between the tab 50 and the hook 30, and pushing the post 48 of the lid 14 into the tunnel sections 44 and 46 lifts the hook 30 upward. The hook 30 is flexible enough to bend upwardly (even with the additional support afforded by the buttress 34). This flexibility allows the tab 50 to slide under the free distal end 38 of the hook 30. During the sliding assembly depicted in Figure 3, as the tab 50 reaches and abuts the second end 42 of the bridge 32, and the leading end 52 of the post 48 is inside the second tunnel section 46 under the bridge 32. When the post 48 is fully inserted into the tunnel sections 44 and 46 (i.e., the leading end of the post within the hook 32 and the trailing end of

the post 54 within the bridge 32 and the center section 56 of the post is disposed between the hook 32 and bridge 30), the free distal end 38 of the hook 30 returns to a position whereby its distal free end is again close to the flange 18. In this position, non-beveled inside lower edge of the free end 38 restricts movement of the tab 50 in a direction that would result in disassembly of the lid 14 and base 12. The free end 38 the hook blocks the post from movement out of the tunnel sections 44 and 46. That is, the free end 38 of the hook 30 will abut the tab 50 when the lid is moved in sliding outward direction, i.e., the reverse of the direction shown by the arrow 64. When assembled, the tab 50 is disposed between the hook 30 and the bridge 32, and the lid 14 can rotate about the post 48 to open and close the closure 10.

When the lid 14 is in its closed position, the plug 15 abuts and seals against the lip 26 of the base 12, and the opening 28 in the base 12 is closed by the cover 47. The closure 10 of the present invention is preferably initially (as provided to a bottler) equipped with a foil liner (not shown) that has a heat sealable layer on its underside. The foil liner (when attached by induction heating to a container neck) provides the closure 10 with a tamper evident seal. When a consumer purchases a container having a lid of the present invention, the foil liner prevents access to the contents of the container. When the consumer wants to dispense the contents, the threaded base 12 is unscrewed, the foil liner is removed, the closure 10 is put back onto the container, the lid 14 is opened by disengaging the bead 60 from the bead 62 and rotating the lid 14 about the post 28, and the desired amount of contents is dispensed. After dispensing, the consumer pushes the lid 14 back into engagement with the base 12, by pressing down on the lid, forcing the bead 60 to snap past the bead 62. This snapping engagement is coincident with the plug 15 engages and seals against the lip 26 on the flange 18. The seal between the plug 15 and the lip 26 help preserve the contents of the container, and limits spillage of the contents from the container.

The bead 60 on the lower interior end of the portion of the lid skirt 49, and bead 62 on an upper portion of the base 12 are both disposed opposite the respective hinge structures on the lid 14 and base 14. The beads are preferably semi-circular in cross-section and preferably have diameter of about 0.032 inches. The beads 60 and 62 are preferably designed to have a center-to-center distance (i.e. the bead 60 passing over and lying below the bead 62 to create such distance), when the lid 14 and base 12 engaged in an uninstalled condition (i.e., not on a container) of about 0.079 inches. It has been found that this extra distance is needed to accommodate the "doming" or upward displacement of the flange 18, and spreading of the skirt 16 of the base 12, as the cap is tightened onto a container. When the closure shown herein is tightened onto a container, and the doming and related stretching and displacement of closure components occurs, a bead arrangement as describe above will allow effective and repeatable latching of the lid 14 to base 14, by the snapping engagement of bead 60 with bead 62.

As depicted in Figure 4, a series of splines 58 extend axially along the post 48, and the splines 58 are space equally about the periphery of the post 48. The eight splines 58 have a relatively small light (about 0.003 inches). The inside surfaces of the hook 30 and bridge 32 are shaped to grip and engage the splines 58 on the exterior of the post 48. The purpose of the splines 58 is to provide the hinge formed by the post 48, hook 30 and bridge 32 accommodate lids 14 of different color. It has been found that different colorants used in plastics, such as low density polyethylene, results in parts having somewhat different shrinkage rates. It is preferable for the post 48 to fit tightly within the tunnel sections 44 and 46 to create friction between the leading end 52 of the post 48 the and the bridge 32 and between the trailing end of the post 54 and the hook 30, so that the lid 14 will be held in an open position as contents of a container used with the closure 10 are dispensed.

Figure 5 shows the hook 30 which, along with the post 48 and the bridge 32 (Figure 6), forms the hinge about which the lid 14 pivots with respect to the base 12. The hook 30 has a free distal end

38 and a fixed proximal end 36 integrally formed with the flange 18 of the base 12. A buttress 34 is disposed adjacent to the fixed proximal end 36 to provide the hook 30 with added support to hold the trailing end 52 of the post 48 in place. A slot 35 is formed in the lid 14 to allow the lid pivot past the buttress 34 allowing the lid 14 to close against the base 12 without interference from the buttress 34.

Figure 4 also shows that the tab 50 has an upper surface that is tangent to the post 48. The distance between the top surface of the tab 50 (and thus the upper surface of the post 48) and the upper surface of the cover 47 of the lid 14 is approximately equal to the thickness of the material that forms the hook 30 and the thickness of the material that forms the bridge 32. This means that the hook 30 and bridge 32 will not extend a significant distance above the upper surface of the cover 47. In addition, when the lid 14 is connected to the base 13, the hinge components (i.e., the post 48, hook 30 and bridge 32) to not project laterally beyond the perimeter of the skirt 16 and do not project above the top of the lid 14 by any appreciable or significant distance. Thus, the hinge of the closure 10 is disposed generally within a space the upper boundary of which is defined by a plane corresponding to the upper surface of the lid 14 and the lateral boundary of which is defined by a cylinder corresponding to the skirt 16. Flexing of the hook 30 and deformation of the bridge 32 may cause those structures to protrude slightly above the plane defined by the upper surface of the lid 14, but as long as that protrusion is relatively small (less than the thickness of the post support, which in the embodiment described herein is a two-part post support in the form of a hook 30 and bridge 32), the hinge structures will still fall generally within the boundaries describe above and will not interfere with the performance of the closure during the feeding operation.

The base 12 has knurls 22 formed on the skirt 16, such that the top of the knurls 22 form a shoulder. The knurls preferably have varying height (Fig. 6) and the lid 14 has a downwardly depending lid skirt 49 that is shaped to fit around an upper knurl-free portion 17 of the skirt 16. The lid

skirt 49 has a outside diameter that is approximately equal to the outside diameter of the knurled section (i.e., the O.D. corresponding to the largest of the knurls), so that the lid skirt 49 is approximately equal in diameter to the diameter of the knurls, and the lower end of the lid skirt 49 lies just above the shoulder 20, when the lid 14 is in a closed position on the base 12. With this configuration, the cap has overall shape that approximates the shape of a standard unitary cap.

These parameters mean that the closure 10 of the present invention will have very similar proportions to standard unitary closures and it will perform well in standard feed systems, such as vibratory feeding bowls and ramp systems of the type that are currently used to feed standard, unitary closures. This means that the closures of the present invention can be used interchangeably with standard caps without any need to replace or otherwise change or modify the closure feeding equipment used in a bottling facility.

An additional purpose and benefit of the closures describe herein is to allow different colored lids 14 to be used with a single (or standard) colored base 12. This allows cap manufacturer to supply a bottler (of milk, for example) with closures that have a single standard base 12, and the cap manufacturer can on very short notice supply caps having a particular color lid 14 (e.g., light blue for skim milk, red for whole milk or yellow for 1%, brown for chocolate etc.) without having actually prepare an injection mold and manufacture a particular cap in response to an order. The manufacturer can simple have a supply of base components on hand and a supply of different colored lids on hand and can quickly assembly the color combinations that a bottler requires. By forming splines 58 on the exterior of the post 48, a lid 14 can be made to have a sufficient frictional hold between the lid 14 and the base 12, regardless of color and the associated variability in shrinkage properties resulting from the use of different colorants. This system has the additional advantage that a single lid mold can be used to form lids of all of the colors (blue, red, yellow, brown etc.) that a customer may desire, because the

forgiveness afforded the splines will allow lids with different shrinkage properties to perform as needed. The friction between the splines 58 and the inside surfaces of the tunnel sections 44 and 46 (formed by the hook 30 and bridge 32, respectively) will hold the lid in an open position and resist the tendency for the lid 14 to be pulled to a closed position onto the base 12 by gravity.

Figure 7 shows a closure 10a installed on a container 66 with a foil liner in place, and Figure 8 shows the same closure 10a installed on the same container 66 without a foil liner. These two figures are intended to show that in order for lid 14 of the closure 10a to align properly with the handle 70 of the container 66 after the foil liner has been removed, the formation of the single threads on the container and the formation of the single thread on the base of the closure must be coordinated. The thickness of a foil liner 68 is typically about 0.007 inches. This means that, as shown in Figure 7, the liner 86 will prevent the cap from being threaded down far enough to have the lid 14 align so that the axis of the hinge will align as it should (as shown in Figure 8) for proper use and dispensing. It is preferable to have the axis of the hinge (shown by line 72 in Figures 7 and 8) be approximately perpendicular to the axis of the handle (shown by line 74), when the contents of the container are being dispensed. The presence of the liner 68 causes the angle between the axis 74 of the handle and the axis of the hinge 72 to be larger (i.e., angle A of about 115 to 120 degrees in Figure 7). However, when the liner 68 is removed, the axis 74 of the handle and the axis of the hinge 72 assume a preferable alignment of about 90 degrees (i.e., angle B in Figure 8). To achieve the desired alignment, as shown in Figure 8, formation of the single thread of the container and the formation of single thread of the closure need to be coordinated, i.e., each needs to be formed with the other in mind, and that formation must take into consideration the effect of the foil liner being removed, so that the alignment of the axis 74 of the handle 70 is about 90 degrees with respect to the axis 72 of the hinge for the enduser when dispensing is desired.

It should be noted that while the closure discussed herein is useful on closures used to deliver beverages, the flip-top closure of the present invention can be used in a wide variety of applications, including medicines (both solid, i.e., pills, and liquids, and a wide variety of other liquids and solids, such as syrups and spices, for example.

The foregoing descriptions of specific embodiments have been presented for purposes of illustration. They are only examples and are not intended to a basis for limiting the scope of the inventions claimed below. It will be apparent to persons of ordinary skill in the field of closure design that many modifications, variations and substitutions are possible in light of the above teachings. The embodiments were chosen and described in order to explain the principles of the inventions claimed below and to demonstrate practical application thereof, and to thereby enable others of ordinary skill in the art to utilize the claimed inventions.

We Claim:

Claim 1: A closure comprising:

a base having a skirt and at least one internal thread formed on an inside surface of the skirt, the base having an opening;

a lid having a depending plug shaped to fit at least partially into the opening of the base; a hinge joining the base and the lid, the hinge comprising:

a post carried by the lid, the post being integrally connected to the lid by a tab;

at least two post supports extending upwardly from the base, one post support being a bridge having a first end and a second end, each of the ends of the bridge being integrally joined to the base, the bridge defining a first tunnel section adapted to receive a first portion of the post, a second post support being a hook with a proximal end being integrally joined to the base and the hook having a free distal end, the hook forming a second tunnel section adapted to receive a second portion of the post, the first and second portions of the post being separated by a middle portion of the post, the middle portion being joined by the tab to the lid.

Claim 2: A closure of claim 1 further comprising:

a beveled portion on the free distal end of the hook, whereby during assembly of the lid to the base, the beveled portion will guide the tab under the distal end of the hook.

Claim 3: A closure of claim 1 further comprising: a buttress formed adjacent an intersection of the proximal end of the hook and the base, whereby the buttress provides the hook with improved resistance to bending from upward forces applied to an inner surface of the hook by the second portion of the post.

Claim 4: A closure of claim 1 further comprising: the at least one thread formed on an inside surface of the skirt being a single helical thread adapted to mate with a single helical thread on a bottle, whereby the closure when installed on a bottle having a handle will generally have a single

alignment in which the direction of opening of the lid will correspond to the location of the handle.

Claim 5: A closure of claim 1 further comprising: a first latch bead on the base and a second latch bead on the lid, the first and second latch beads being positioned to snap past one another and hold the lid in a closed position over the opening in the base.

Claim 6: A closure of claim 1 further comprising: the post having at least one generally axially extending external rib, the rib being deformable when the post is inserted into at one of the tunnel sections.

Claim 7: A closure of claim 6 wherein the post has eight generally axially extending external ribs, the ribs being generally equally spaced about the perimeter of a portion of the post and each rib having a height of about 0.003 inches.

Claim 8: A closure of claim 1 wherein the bridge and the hook have a height that is approximately equal to an elevation of an upper surface of the lid when the lid is attached to the base, and the base includes a platform from which the bridge and hook extend upwardly, the bridge and hook being disposed in plan view within the periphery of the closure, whereby the hinge does not extend either radially from the closure beyond the skirt or axially a substantial distance beyond the lid, when the lid is assembled to the base.

Claim 9: A closure of claim 1 wherein the skirt has a lower skirt section and an upper skirt section, and axially extending knurls are disposed over a major portion of an exterior surface of the lower skirt section, an upper portion of the skirt section being with knurls, such that the top of the knurls form a shoulder, and the lid having a downwardly depending lid skirt that is shaped to fit around an upper portion of the skirt, the lid skirt having a thickness that is approximately equal to the depth of at least some of the knurls.

Claim 10: A closure of claim 1 wherein the lid is made of a plastic containing a first colorant, and the base is made of a plastic containing a second colorant, and the first and second

colorants are different.

Claim 11: A two-piece closure comprising:

a base having a skirt a thread formed on an inside surface of the skirt, the base having an opening;

a lid having a depending plug shaped to fit into the opening of the base;a hinge joining the base and the lid, the hinge comprising:

a post carried by the lid, the post being integrally connected to the lid by a tab;

a post support extending upwardly from the base, the post support being integrally joined to the base and defining a tunnel section adapted to receive a portion of the post, the tab being joined to the lid by a tab;

the hinge being disposed substantially within a space defined by a plane corresponding to the upper surface of the lid, and a cylinder generally corresponding to an outermost portion of the skirt.

Claim 12: A closure of claim 11 wherein the post support is comprised of two upwardly extending formations, one formation being a hook having a fixed end and a free end, and a second formation being bridge having two fixed ends, each of the hook and bridge defining a tunnel section for receiving portions of the post.

Claim 13: A closure of claim 12 wherein a beveled portion is formed on the free end of the hook, whereby during assembly of the lid to the base, the beveled portion will guide the tab under the distal end of the hook during a sliding assembly of the lid to the base.

Claim 14: A closure of claim 13 wherein the tab has a width that is less than a distance that separates the hook and the bridge, such that when the tab slides under the free end of the hook and is disposed between the hook and the bridge, the hook moves in the direction of an original position of the hook and the free end of the hook blocks the tab and restricts disassembly of the lid from the base.

Claim 15: A closure in accordance with claim 11 wherein the lid includes a colorant that is

not present in the base.

Claim 16: A closure in accordance with claim 11 wherein the base has a single helical internal thread formed on the inside of the skirt.

Claim 17: A closure in accordance with claim 11 wherein the post has eight generally axially extending external ribs, the ribs being generally equally spaced about the perimeter of a portion of the post and each rib having a height of about 0.003 inches.

Claim 18: A closure comprising:

a base having a skirt and a single internal thread formed on an inside surface of the skirt, the base having an opening;

a lid having a depending plug shaped to fit at least partially into the opening of the base; a hinge joining the base and the lid, the hinge comprising:

a post carried by the lid, the post being integrally connected to the lid by a tab;

at least two post supports extending upwardly from the base, one post support being a bridge having a first end and a second end, each of the ends of the bridge being integrally joined to the base, the bridge defining a first tunnel section adapted to receive a first portion of the post, a second post support being a hook with a proximal end being integrally joined to the base and the hook having a free distal end, the hook forming a second tunnel section adapted to receive a second portion of the post, the first and second portions of the post being separated by a middle portion of the post, the middle portion being joined by the tab to the lid;

the hinge being disposed substantially within a space defined by a plane corresponding to the upper surface of the lid, and a cylinder generally corresponding to an outermost portion of the skirt.

Claim 19: A closure in accordance with claim 18 wherein the lid includes a colorant that is not present in the base.

Claim 20: A closure in accordance with claim 18 wherein the post has eight generally

axially extending external ribs, the ribs being generally equally spaced about the perimeter of a portion of the post and each rib having a height of about 0.003 inches.



Application No: GB1510193.4

Examiner: Mr Kevin Gartland

Claims searched: 1-10, 18-20 in part

Date of search: 2 November 2015

Patents Act 1977: Search Report under Section 17

Documents considered to be relevant:

| Category | Relevant to claims | Identity of document and passage or figure of particular relevance |
|----------|--------------------|--|
| A | - | US6702109 B1 TOA |
| A | - | WO2014/201645 A1 SIEMENS |
| A | - | US4513888 A CURRY |
| A | - | US4821899 A OWENS ILLINOIS |

Categories:

| | |
|---|--|
| X Document indicating lack of novelty or inventive step | A Document indicating technological background and/or state of the art. |
| Y Document indicating lack of inventive step if combined with one or more other documents of same category. | P Document published on or after the declared priority date but before the filing date of this invention. |
| & Member of the same patent family | E Patent document published on or after, but with priority date earlier than, the filing date of this application. |

Field of Search:

Search of GB, EP, WO & US patent documents classified in the following areas of the UKC^X :

| |
|--|
| |
|--|

Worldwide search of patent documents classified in the following areas of the IPC

B65D

The following online and other databases have been used in the preparation of this search report

EPODOC, WPI

International Classification:

| Subclass | Subgroup | Valid From |
|----------|----------|------------|
| B65D | 0047/08 | 01/01/2006 |