

AUSTRALIA

PATENTS ACT 1990

PATENT REQUEST: STANDARD PATENT

We, OWENS-ILLINOIS CLOSURE INC. , being the person identified below as the Applicant, request the grant of a patent to the person identified below as the Nominated Person, for an invention described in the accompanying standard complete specification.

Full application details follow:

Applicant: OWENS-ILLINOIS CLOSURE INC.
Address: One SeaGate, Toledo, Ohio 43666, United States of America
Nominated Person: As above
Address: As above
Invention Title: "CLOSURE WITH SNAP-TYPE HINGE CAP"
Name of actual Inventor: Timothy J. FUCHS

BASIC CONVENTION APPLICATION DETAILS

Application Number: 08/322,636
Country: United States of America
Country Code: US
Date of Application: 13th October, 1994

Drawing number recommended to accompany the abstract: Figure 1

Address for service is: SHELSTON WATERS
60 MARGARET STREET
SYDNEY NSW 2000

Attorney Code: SW

DATED this 10th Day of October, 1995.
OWENS-ILLINOIS CLOSURE INC.

by 
Fellow Institute of Patent Attorneys of Australia
of SHELSTON WATERS

To: The Commissioner of Patents
WODEN ACT 2606

File:18336
Fee: \$280.00

S 060111 101095

P/00/008
Section 29(1)
Regulation 3.1(2)

AUSTRALIA

PATENTS ACT 1990

NOTICE OF ENTITLEMENT

We, OWENS-ILLINOIS CLOSURE INC.

of One SeaGate, Toledo, Ohio 43666, United States of America, being the applicant in respect of an Application for an invention entitled:

CLOSURE WITH SNAP-TYPE HINGE CAP

state the following:-

1. The person nominated for the grant of the patent has entitlement from the actual inventor/s by assignment.
2. The person nominated for the grant of the patent has entitlement from the applicant/s of the basic application/s listed on the patent request form by assignment.
3. The basic application/s listed on the patent request form is/are the first application/s made in a Convention country in respect of the invention.

.....
(Signature)

October 18, 1995

.....
(Date)

Name: H. G. BRUSS

Title: Assistant Secretary

File: 16670 AUST

SHELSTON WATERS
60 MARGARET STREET, SYDNEY, AUSTRALIA



AU9533167

(12) PATENT ABRIDGMENT (11) Document No. AU-B-33167/95
(19) AUSTRALIAN PATENT OFFICE (10) Acceptance No. 699311

- (54) Title
CLOSURE WITH SNAP-TYPE HINGE CAP
- International Patent Classification(s)
(51)⁶ B65D 047/08
- (21) Application No. : 33167/95 (22) Application Date : 10.10.95
- (30) Priority Data
- (31) Number (32) Date (33) Country
08/322636 13.10.94 US UNITED STATES OF AMERICA
- (43) Publication Date : 02.05.96
- (44) Publication Date of Accepted Application : 03.12.98
- (71) Applicant(s)
OWENS-ILLINGIS CLOSURE INC.
- (72) Inventor(s)
TIMOTHY J. FUCHS
- (74) Attorney or Agent
BALDWIN SHELSTON WATERS , Level 21, 60 Margaret Street, SYDNEY NSW 2000
- (56) Prior Art Documents
US 4573600
EP 0494306
EP 0608755
- (57) Claim

A closure with a snap type hinge cap comprising
a first part adapted to interengage with the open neck of
a container,
a second part forming a cap,
an integral hinge interconnecting the first part and
second part,
each of said parts comprising a base wall and a
peripheral skirt,
a pair of hinged straps being attached to said skirts and
extending from the skirts on opposite side of said integral hinge,
each said strap having a uniform cross section throughout
its length between the points of attachment to said skirts,
the ends of said straps being straight and lying in
substantially the same plane when the first part and second part
are in fully open position,
each said strap being stretched along its length during
opening and closing of said first part and second part,

(11) AU-B-33167/95
(10) 699311

-2-

each said strap having a portion intermediate said ends which extends out of said plane when the first part and second part are in fully open position,

each said strap being untensioned when the first part and second part are in fully open position.

- 1 -

AUSTRALIA

PATENTS ACT 1990

COMPLETE SPECIFICATION

FOR A STANDARD PATENT

ORIGINAL

Name of Applicant: OWENS-ILLINOIS CLOSURE INC.

Actual Inventor: Timothy J. FUCHS

Address of Service: SHELSTON WATERS
60 MARGARET STREET
SYDNEY NSW 2000

Invention Title: "CLOSURE WITH SNAP-TYPE HINGE CAP"

The following statement is a full description of this invention, including the best method of performing it known to us:-

CLOSURE WITH SNAP-TYPE HINGE CAP

This invention relates to closures and particularly to closures of the type which include a cap that is connected to the remainder of the closure by an integral hinge.

Background and Summary of the Invention

5 It has heretofore been proposed that closures be provided for containers wherein the closures on the container by an integral hinge. Conventionally, such closures rely on tension on the hinge to produce a snap action. Typical constructions are shown in U.S. Patent Nos. 3,628,215, 3,629,901,
10 3,933,271, 4,047,495, 4,386,714.

In United States Patent 4,638,916, a closure with a snap type hinge cap comprises a first part adapted to interengage with the open neck of a container, a second part forming a cap and an integral hinge interconnecting the first and second parts
15 comprises a base wall and a peripheral skirt. A pair of hinge straps extends from the skirts and are positioned on opposite sides of the integral hinge. The radial length of the pair of hinge straps is less than the length of the arc through which the second cap part moves to and from and closed position
20 relative to the first part such that the pair of straps stretch to function as springs. The ends of the pair of straps are

attached to the skirts radially inwardly of the periphery of the skirts.

It is an object of the present invention, at least in the preferred embodiments to overcome or substantially ameliorate one or more of the disadvantages of the prior art.

According to the invention there is provided a closure with a snap type hinge cap

5 comprising:

a first part adapted to interengage with the open neck of a container;

a second part forming a cap;

an integral hinge interconnecting the first part and second part;

each of said parts comprising a base wall and a peripheral skirt;

10 a pair of hinged straps being attached to said skirts and extending from the skirts on opposite side of said integral hinge;

each said strap having a uniform cross section throughout its length between the points of attachment to said skirts;

the ends of said straps being straight and lying in substantially the same plane

15 when the first part and second part are in fully open position;

each said strap being stretched along its length during opening and closing of said first part and second part;

each said strap having a portion intermediate said ends which extends out of said plane when the first part and second part are in fully open position;

20 each said strap being untensioned when the first part and second part are in fully open position.

Unless the context clearly requires otherwise, throughout the description and the claims, the words 'comprise', 'comprising', and the like are to be construed in an inclusive as opposed to an exclusive or exhaustive sense; that is to say, in the sense of
25 "including, but not limited to".



FIG. 2 is a sectional view taken along the line 2-2 in FIG. 1;

FIG. 3 is a sectional view on an enlarged scale taken along the line 3-3 in FIG. 1;

FIG. 4 is a sectional view on an enlarged scale taken along the line 4-4 in FIG. 1;

FIG. 5 is a fragmentary elevational view showing the closure in a closed position;

5 FIG. 6 is a fragmentary sectional view of a portion of the closure;

FIG. 7 is a sectional elevational view of the closed closure;

FIG. 8 is a plan view of a modified form of closure in an open position;

FIG. 9 is a sectional view on an enlarged scale taken along the line 9-9 in FIG. 8;

and

10 FIG. 10 is a sectional view on an enlarged scale taken along the line 10-10 in

FIG. 8.

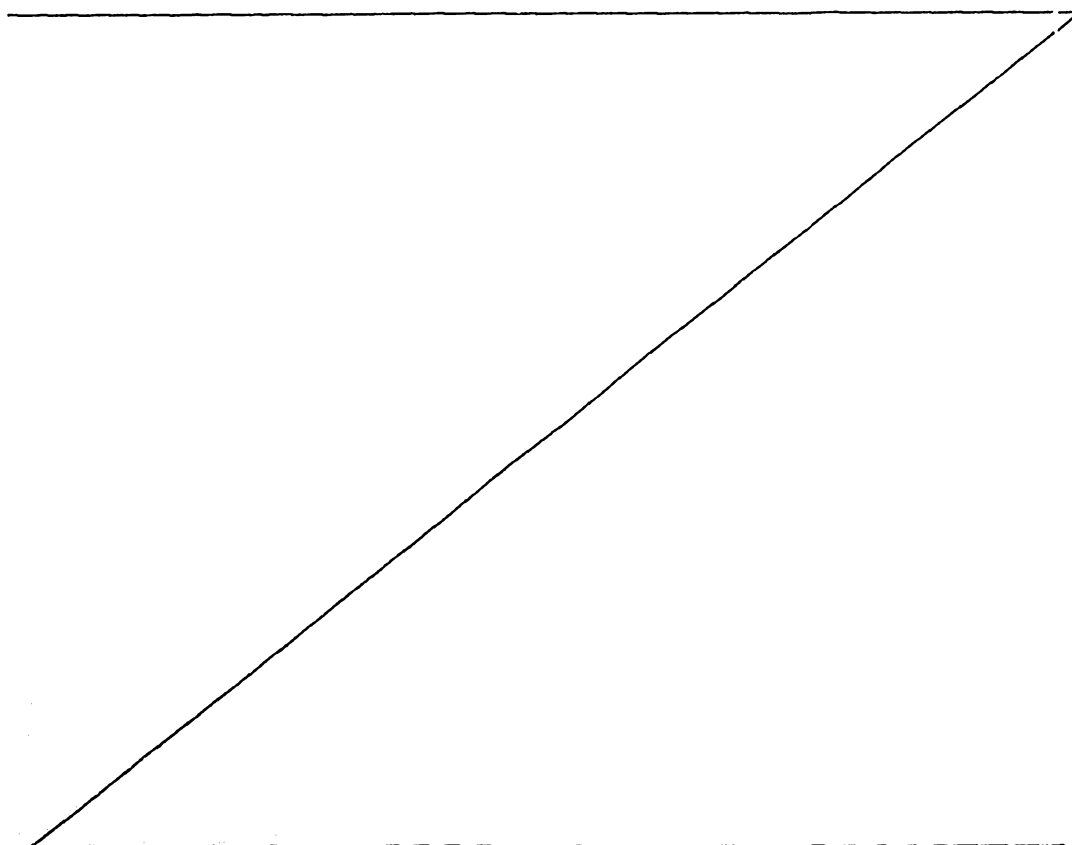

Description of the Preferred Embodiments

Referring to FIGS. 1-7, the closure 10 embodying the invention is made of plastic such as polypropylene and comprises a first part 11 which is adapted to be threaded on the neck of a container, a second part 12 which forms a cap and an integral hinge 13 connecting the first part 11 and second part 12.

The first part includes a base wall 14 and a peripheral skirt 15 with a shoulder 16 at the juncture of the base wall 14 and a peripheral skirt 15. A tubular spout 17 extends from the exterior surface of base wall 14 and terminates in a chamfer rim 17a. An annular bead 18 is formed on the inner surface of the spout 17. The skirt 15 is formed with an internal thread 19 on the inner surface thereof for engagement with the threads on the neck of a container. The spout 17 provides a dispensing outlet for the contents of a container on which the closure is applied.

The second or cap part 12 is formed with a base wall 20 and a peripheral skirt 21. Shoulder 16 is adapted to be engaged by the free edge of the skirt 21. A cylindrical wall 22, is provided on the inner surface of the base wall 20 and is adapted to telescope into the spout 17 when the cap is moved to closed position. Rib 18 provides a friction fit for wall 22 to both insure a tight seal for the contents of the container and clean the spout of contents. The friction fit also secures the second part in closed position.

Integral hinge 13 has a length several times its width to provide stability. The hinge 13 has its upper surface in the plane of the shoulder 16 and the free edge of the skirt 21. The under side of the hinge 13 is in the form of an inverted V
5 in radial cross section. Hinge straps 25 are provided, one on each side of hinge 13. The length of the integral hinge 13 is several times the width of each of the straps 25.

Each strap 25 extends between a recess 26 on part 11 and a recess 27 on part 12. The end of each strap 25 is connected
10 the recesses 26, 27 horizontally as viewed in FIG. 4.

The configuration of each strap 25 is such that the straps stretch in operation; i.e., in opening and closing part 12 on part 11.

Each strap 25 has its ends straight and lying in the
15 same plane when the first part 11 and second part 12 are in fully open position. In this position an intermediate portion 25a of each strap 25 which extends axially out of the plane, herein shown as upwardly curved (FIGS. 3,4).

In the modified form shown in FIGS. 8-10, corresponding
20 parts are designated with the suffix "a". This form differs in that the intermediate portion 25b of each strap is V-shaped in cross section and extends downwardly.

It can thus be seen that there has been provided a
25 closure of the snap-hinge type improved performance and longer life; which reduces or eliminates excessive stress on the straps during opening and closing which might cause breaking; and which can be made with minimal added cost.

THE CLAIMS DEFINING THE INVENTION ARE AS FOLLOWS:-

A closure with a snap type hinge cap comprising
a first part adapted to interengage with the open neck of
a container,

5 a second part forming a cap,
an integral hinge interconnecting the first part and
second part,

each of said parts comprising a base wall and a
peripheral skirt,

10 a pair of hinged straps being attached to said skirts and
extending from the skirts on opposite side of said integral hinge,
each said strap having a uniform cross section throughout
its length between the points of attachment to said skirts,

15 the ends of said straps being straight and lying in
substantially the same plane when the first part and second part
are in fully open position,

each said strap being stretched along its length during
opening and closing of said first part and second part,

20 each said strap having a portion intermediate said ends
which extends out of said plane when the first part and second part
are in fully open position,

each said strap being untensioned when the first part and
second part are in fully open position.

2. The closure set forth in claim 1 wherein said
25 intermediate portions of said straps extend axially in one of an

axially downwardly or an axially upwardly direction out of said plane when the first part and second part are in fully open position.

3. The closure set forth in claim 2 wherein said
5 intermediate portions of said straps are curved in cross section along the length of said intermediate portions.

4. The closure set forth in claim 2 wherein said intermediate portions of said straps are V-shaped in cross section along the length of said intermediate portions.

10 5. The closure set forth in any one of claims 1-4 wherein the end of each said strap is connected horizontally to said skirt of said first part and said skirt of said second part.

15 6. The closure set forth in claim 5 wherein said skirt of each first part and said skirt of said second part has recesses, said straps having their ends being attached in said recesses.

7. A closure with a snap type hinge cap substantially as herein described with reference to Figures 1 to 7 or Figures 8 to 10 of the accompanying drawings.

DATED this 10th Day of October, 1995

OWENS-ILLINOIS CLOSURE INC.

Attorney: JOHN B. REDFERN
Fellow Institute of Patent Attorneys of Australia
of SHELSTON WATERS

ABSTRACT OF THE DISCLOSURE

A closure (10) with a snap type hinge cap comprising a first part (11) adapted to interengage with the open neck of a container, a second part (12) forming a cap and an integral hinge (13) interconnecting the first part (11) and second part (12). Each of the parts (11, 12) comprises a base wall (14, 20) and a peripheral skirt (15, 21). A pair of hinged straps (25) extend from the skirts (15, 21) on opposite side of said integral hinge (13). The ends of the straps (25) are substantially straight and lie in substantially the same plane when the first part (11) and second part (12) are in fully open position. Each strap (25) has a portion intermediate the ends which extends out of the plane. Each strap is untensioned when the first part (11) and second part (12) are in fully open position. The intermediate portions (25a) of the straps extend axially in one direction. In one form, the intermediate portions (25a) of the straps (25) are curved in cross section. In another form, the intermediate portions (25a) of the straps (25) are V-shaped in cross section.

FIG. 1

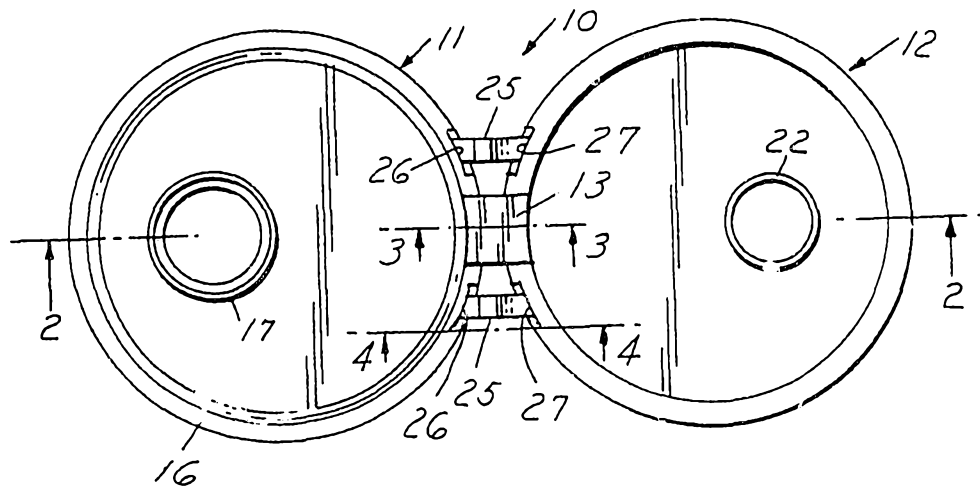

FIG. 2

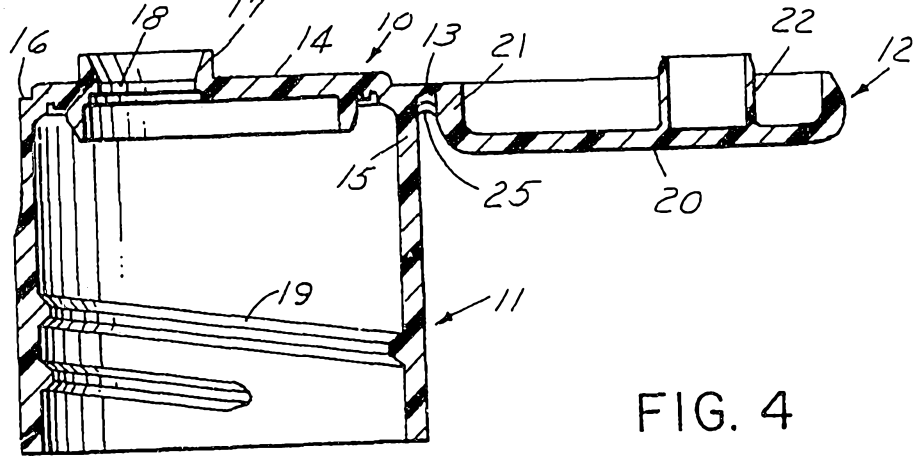

FIG. 3

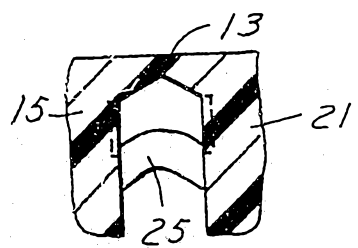

FIG. 4

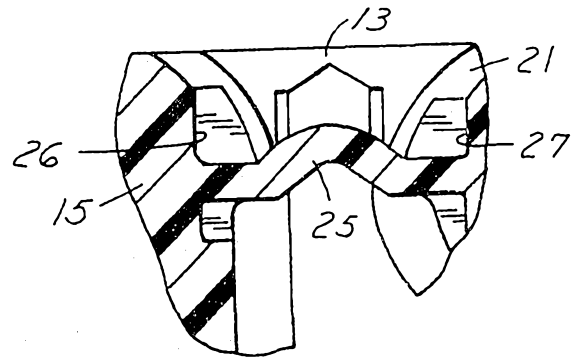

FIG. 5

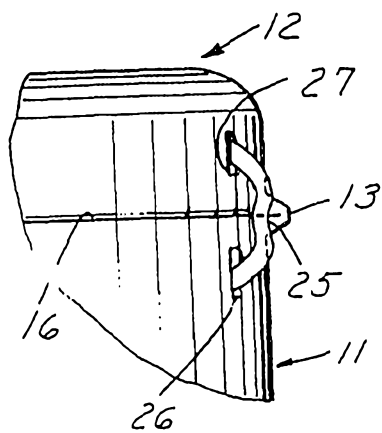

FIG. 6

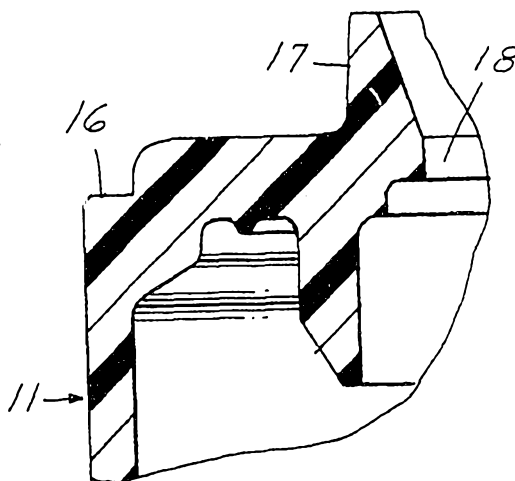

FIG. 7

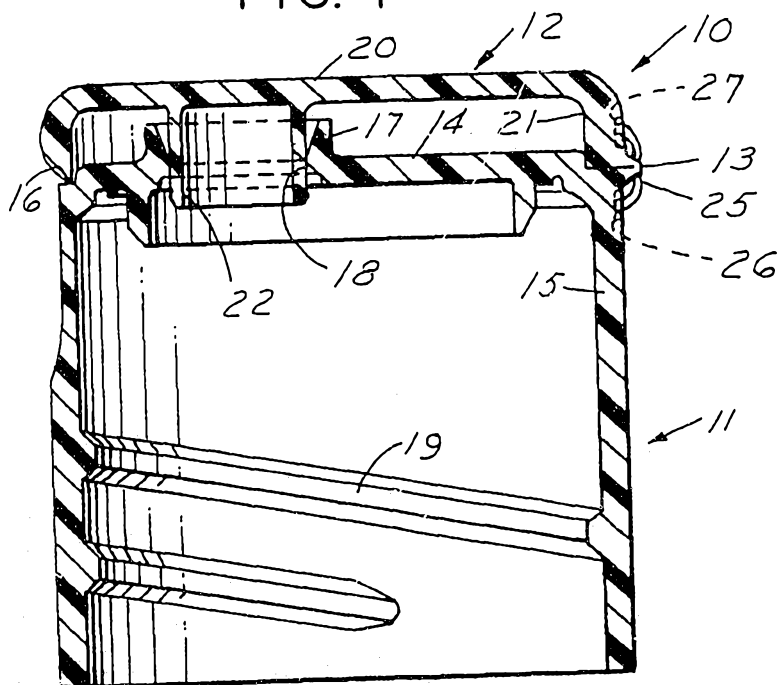

FIG. 8

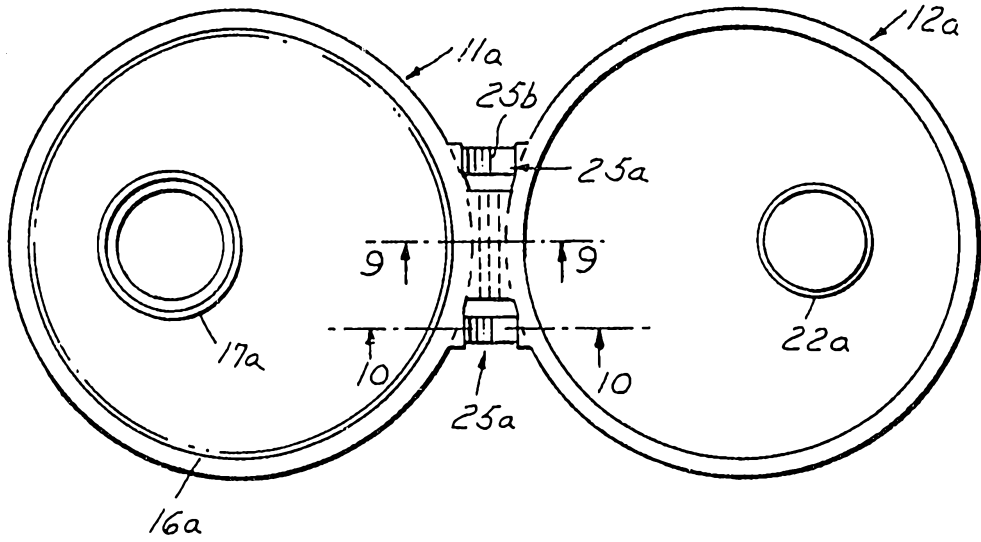

FIG. 9

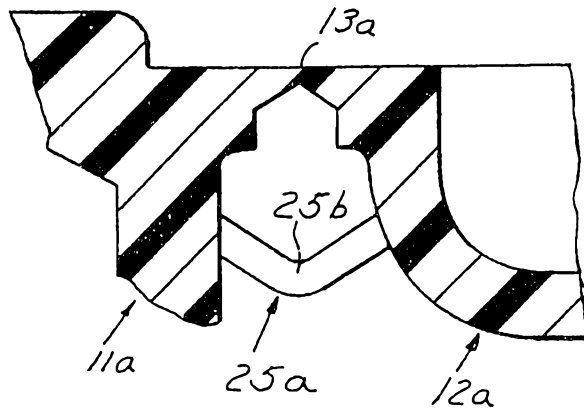

FIG. 10

