

No. 814,104.

PATENTED MAR. 6, 1906.

A. E. WILCOX.
OILER FOR VEHICLE WHEELS.
APPLICATION FILED AUG. 1, 1906.

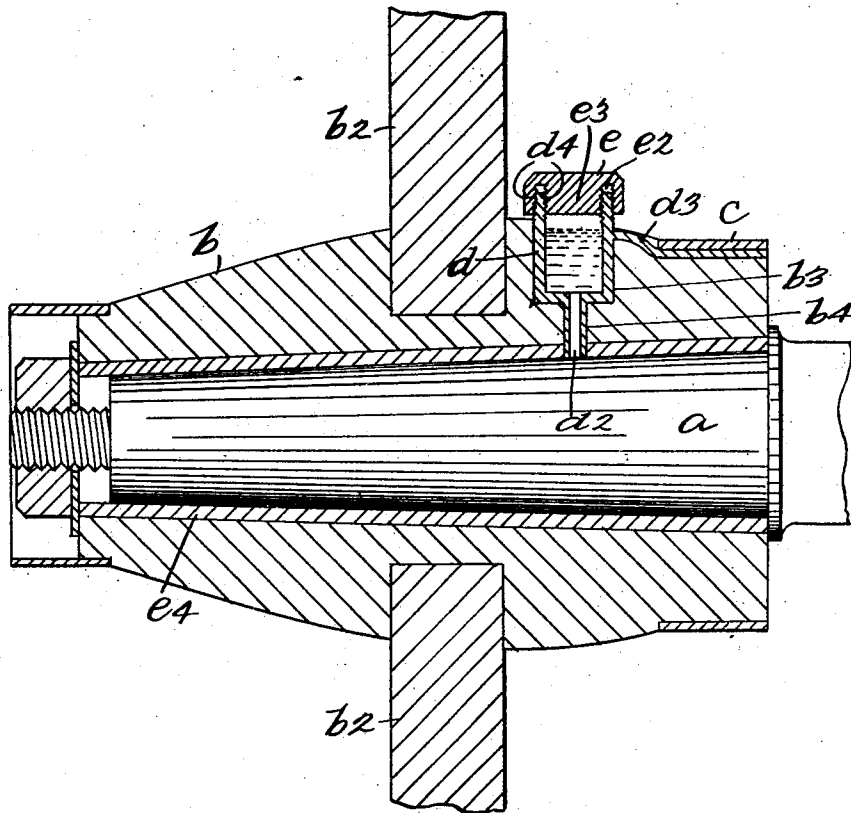

WITNESSES

J. B. Larsen
F. A. Stewart

INVENTOR

Albert E. Wilcox

BY

Edgar Sater & Co.

ATTORNEYS

UNITED STATES PATENT OFFICE.

ALBERT ESTE WILCOX, OF MILLVILLE, MASSACHUSETTS.

OILER FOR VEHICLE-WHEELS.

No. 814,104.

Specification of Letters Patent.

Patented March 3, 1906.

Application filed August 1, 1905. Serial No. 272,154.

To all whom it may concern:

Be it known that I, ALBERT ESTE WILCOX, a citizen of the United States, residing at Millville, in the county of Worcester and State of Massachusetts, have invented certain new and useful Improvements in Oilers for Vehicle-Wheels, of which the following is a specification, such as will enable those skilled in the art to which it appertains to make and use the same.

This invention relates to oiling or lubricating devices for vehicle-wheels; and the object thereof is to provide an improved device of this class which may be conveniently and easily applied to vehicle-wheels of the usual construction, whereby said wheels or the spindles thereof may be kept properly lubricated at all times.

The invention is fully disclosed in the following specification, of which the accompanying drawing forms a part, in which the separate parts of my improvement are designated by suitable reference characters, said drawing being a central longitudinal section through the hub of a wheel and showing the same mounted on a spindle and provided with my improved oiler or lubricator.

In the drawing forming part of this specification I have shown at *a* one of the spindles of a vehicle, and I have also shown a wheel-hub *b* mounted thereon, the spokes of the wheel being represented at *b*². The hub *b* is of the usual form, and the inner end thereof is provided with the usual band *c*, and in practice I provide an oil-cup *d*, which is adapted to be countersunk in the enlarged portion of the hub adjacent to the spokes *b*² and which is provided at its inner end with a tube or nozzle *d*², which passes through the inner part of the hub and through the spindle sleeve or casing *e*², which is secured therein and into the central bore or spindle space. The oil-cup *d* is provided at one side with an arm *d*³, over which the band *c* is passed, and said band securely holds the cup in place.

The oil-cup *d* in practice is placed in a recess or chamber *b*³, formed in the hub *b*, and the tube or nozzle *d*² is passed through a bore *b*⁴, which communicates with the recess or chamber *b*³, and the outer end of the oil-cup

is threaded both internally and externally, as shown at *d*⁴, and said oil-cup is also provided with a cap *e*, having a deep annular groove *e*², both walls of which are threaded, and by means of this construction the cap *e* is provided with a centrally inwardly directed member *e*³, and in practice the cap is secured on the oiling-cup, as shown in the drawing, and this form of construction not only provides a perfectly tight closure for the oil-cup, but also places the oil or other lubricating material in said cup under pressure.

My improved oiling or lubricating device may be applied to wheels of various kinds and classes or to wheels of vehicles used for various purposes.

Having fully described my invention, what I claim as new, and desire to secure by Letters Patent, is—

1. An oil-cup for the hubs of vehicle-wheels provided at one end with a projecting tube or nozzle, said cup being open at the opposite end and provided with a cap having an annular groove into which the open end of the cup is screwed, both walls of said groove being threaded and the open end of the cup being externally threaded, and said cup being also provided at one side with a projecting arm, substantially as shown and described.

2. A wheel-hub provided on the inner sides of the spokes of the wheel with an oil-cup which is set thereinto radially thereof, said cup being open at its outer end and provided with a closure-cap, said cup being also provided at its inner end with a tube or nozzle which communicates with the spindle-space, and being also provided at one side with a radial arm, and said wheel-hub being provided at its inner end with a band which is passed on over said arm, substantially as shown and described.

In testimony that I claim the foregoing as my invention I have signed my name, in presence of the subscribing witnesses, this 28th day of July, 1905.

ALBERT ESTE WILCOX.

Witnesses:

AMBROSE B. WHITE.
ALONZO MOURY.